

Ngā tikanga hautū waka o Aotearoa: te puka ōkawa

Hei puka tātaki māu e
whai ana i tō raihana ako

2024



© Waka Kotahi NZ Transport Agency 2024

Nō Waka Kotahi NZ Transport Agency te manatā o te tānga nei. Ko ngā hua o roto ka āhei te tā hei whakamahi mā ngā kaupapa tūmataiti, mā ngā kaupapa rāroto rānei me te kore o te whakaaetanga ōkawa, o te utu rānei, mēnā e tika ana te tautohu i te tānga nei me Waka Kotahi hoki hei mātāpuna. Ko ngā tono me ngā pātai mō te tāruatanga o ngā hua o roto o te tānga nei mō tētahi take kē atu me tuku atu ki te Information Manager, Waka Kotahi, Private Bag 6995, Wellington 6141.

Kāore e kapi i ngā whakaaetanga mō te tāruatanga o ngā kōrero i te tānga nei ko ōna hua o roto e puritia nei te manatā e tētahi kaupupuri kē atu i a Waka Kotahi. E tāruatia ai ngā hua e puritia nei te manatā e kaupupuri kē atu, me mātua whakaae e ngā kaupupuri i te manatā e whai pānga ana.

Ngā tikanga hautū waka o Aotearoa: te puka ōkawa

ISBN 978-1-99-106883-5 (print)
978-1-99-106882-8 (online)

Ngā pātai hokohoko

David Bateman Limited
Phone: (09) 415 7664
info@batemanbooks.co.nz

He tuku haepapa

Kua whai a Waka Kotahi kia tika katoa ngā kōrero i te tuhinga nei, ā-tukanga, ā-ture anō hoki. Heoi anō, ko te puka tikanga hautū waka nei he whakarāpopototanga o ngā ture i te reo māmā, nō reira ko te ture ake e noho mātāmua ana. Kāore mātou e noho haepapa ki ngā pānga katoa o te whakamahinga o te tuhinga nei. Ki te kore koe e mōhio mēnā rānei e tika ana ngā kōrero i te pukapuka nei, tirohia te ture e hāngai ana. Ka kitea aua ture i te ipurangi ki legislation.govt.nz

He whakataki

Ko te pukapuka nei mā te kaihautū o te motokā, o ngā momo waka taimāmā kē atu hoki.

Ākona kia haumarū ai, kia whai tikanga ai hoki tō hautū waka mā *Ngā tikanga hautū waka o Aotearoa: te puka ōkawa*. Kei roto nei ngā mōhiohio katoa e hiahia ana e whiwhi ai koe i tō raihana ako.

Ko te puka nei mō ngā ture waka whenua o Aotearoa me ngā tikanga e haumarū ai te hautū waka, e whakamātautauhia ai koe hei te wā o ō aromatawai hautū waka, ko ngā whakamātautau ariā, ko ngā whakamātautau hautū waka anō hoki. E kapi ana ko ētahi kaupapa whānui, tae atu ki ngā haepapa ā-ture o te hunga whai waka, me ngā here ā-ture e hāngai ana ki tō waka.

Kei te wāhanga o muri o te pukapuka nei ngā pātai ka whiua pea ki a koe hei tō whakamātautau ariā mō tō raihana ako.

Ka tāngia hoki e Waka Kotahi ētahi puka tikanga hautū mō ngā kaihautū i te waka taimaha, i te motupaika, me te pahikara anō hoki. Katoa ā mātou puka tikanga hautū kei te ipurangi, kei nzta.govt.nz/roadcode/general-road-code

Ngā whakahoutanga kei te ipurangi

Ahako te āta hōmiromirotia o tēnei pukapuka kia tika katoa ai i tōna tānga, he wā pea ōna mā te panonihia o te ture ā muri i te tānga e hē ai ētahi o ngā mōhiohio i roto nei.

E toro ki nzta.govt.nz/road-code-updates mō ngā mōhiohio tika katoa o nāianeī.

Ngā kōrero o roto

He whakataki	1
Kia haumaruru te pūnaha rori	6

Mō te raihana hautū **8**

Te pūnaha raihana hautū o Aotearoa	8
Me pēhea te whai i tō raihana hautū	12
Tūārere 1 - te raihana ako	13
Tūārere 2 - te raihana here	18
Tūārere 3 - te raihana matua	20
Ngā herenga o te tono raihana hautū	21
He mōhiohio anō mō te raihana	25

Mō ngā tohu **28**

Ngā momo tohu matua	28
Ngā momo tohu e toru	28
Ngā tohu waka	34

Mō te hautū waka **38**

Ngā pūkenga hautū matua	38
Te ū ki te taha mauī	38
Te tūtohu	40
He tūtohu kē atu	43
Te huri	45
Te whakamahi tika i ngā ara	51
Te tawhiti whaiwhai	55
Te tohipa	57
Te kōmiti	65
Te hautū i te ara matua	67
Te haere whakamuri	68

Te tautuku	69
He aha rānei te pūtahi?	69
Te ahu atu ki te pūtahi	70
Ngā tikanga tautuku	73
Te tautuku i ngā pūtahi porotaka	81
Te tautuku i ngā whakawhitinga ara tereina	85
Te tautuku i te arawhiti ara-kotahi	87
Te tū me te whakatū waka	88
Te whakatū waka kia haumaruru ai	88
Ngā wāhi kāore e whakaaetia te whakatū waka	90
Ngā tohu whakatū waka	92
Te aukati i ngā pūtahi me ngā whakawhitinga waehiko	95
Ngā ara mō te pahikara anake	96
Te pouaka tū tōmua	96
Te huringa matika	96
Ka huri ana te taiao hautū	97
Te hautū i te huarere kino	97
Te hautū i te pō	99
Ngā mahinga rori	102
Te kāpō hihirā	104
Te kiri rori	105
Ngā mōreareatanga me ngā take ohotata	107
Te aro ki ngā mōreareatanga	107
Ngā mōreareatanga huhua	109
He kupu āwhina mō te hautū, kia haumaruru ai	111
He kupu āwhina mō te aro ki ngā āhuratanga hautū ohotata	114

Mō ngā tepenga

122

Ngā paetere

122

Ngā aratohu mō te tere e haumarua ana 122

Ngā tepenga mō te waipiro me te pūroi 128

Te ruha kaihautū 130

Mō ngā haepapa o te kaihautū

134

Ngā haepapa o te tangata rēhita 134

Te hautū matatika 135

Te tātua nōhanga me te whakaita tamariki 140

Te mūhoretanga waka 142

Ngā tukinga waka 143

Te takahi ture 146

Kia iti iho ngā pānga taiao o te hautū waka 148

Mō tō waka

150

Ngā herenga o te waka 150

Te whakautu me te tō mō te waka taimāmā 154

Ngā here mō te tauaru taimāmā 156

Mō kaitāwhai kē atu i te rori

160

Te haere tahi i te rori

160

Te haere tahi i te rori ki te waehīkoi 160

Te haere tahi i te rori ki te hunga eke pahikara 164

Te haere tahi i te rori ki te taraka me te pahi 166

Te haere tahi i te rori me te tarakihana 167

Te haere tahi i te rori ki te waka whakahara 168

Te haere tahi i te rori ki te kaieke motupaika 168

Te haere tahi i te rori ki ngā kaieke hōiho 169

He mōhiohio mō kaitāwhai kē atu	170
He aratohu whānui mā te waehīkoi	170
He mōhiohio mō te hunga eke pahikara	172
He mōhiohio mō te hunga eke hōiho	173
He mōhiohio mō te kaihautū i te waka ahuwheua	173
He mōhiohio mō te hunga eke kutariki	174
He mōhiohio mō te hunga eke i te taumatua neneke, i ngā taputapu runaruna rānei e whai wira ana	176

Te puka tātaki ki te whakamātautau raihana ako **178**

Ngā pātai whānui	178
Ngā pātai matua (M)	179
Ngā pātai mō te whakatū waka (WW)	185
Ngā pātai mō ngā take ohotata (O)	187
Ngā pātai mō ngā tohu me ngā tānga (T)	189
Ngā pātai mō ngā tūnga i te rori (R)	197
Ngā pātai whanonga (N)	198
Ngā pātai mō ngā pūtahi (P)	205
Ngā pātai motuhake mā te kaihautū motokā	217

Kuputaka **222**

He whakamāramatanga kupu	225
---------------------------------	------------

Rārangi kuputohu **228**

Kia haumarū te pūnaha rori

Me tae haumarū atu te katoa ki te wāhi e ahu nei rātou, ahakoa mā raro, mā runga pahikara, mā te hautū waka, mā te motupaika, mā te eke waka tūmatanui rānei.

E tutuki ai tēnei, me mātua whakapai ake ngā wāhanga katoa o te pūnaha waka whenua. Mā tātou katoa tēnei mahi - tae atu ki ngā tāngata katoa e haere ana mā ō tātou rori, ki ngā kaimahi katoa anō hoki o te rāngai waka whenua.

E āhei ana tō āwhina mā te kōwhiri kia:

- » hoko i te waka haumarū katoa ka āhei ai tō pūkoro, hei ārai i a koutou ko ō āpiti ina tūtuki te waka
- » āta tiakina tō waka
- » ū ki ngā paetere haumarū e tika ana mō ngā rori me ngā āhuetanga e hāngai ana - pērā i te huarere, i ērā atu waka i te rori, i te haumarū o tō waka, me te nui o tō whai wheako
- » aronui ki te tika o tō hautū waka, kia mataara hoki ki ngā mōreareatanga i ngā tahataha rori
- » mātua whakarite e nui ai te wā mō tō haerenga - ahakoa pēhea te tawhiti
- » haumarū te haere tahi i te rori ki tangata kē atu
- » kua e haurangi, e māngina rānei i a koe e hautū waka ana, me te āki hoki i ō hoa kia kua hoki e pērā.

Ka mahi tahi mātou ko ō mātou hoa whakahaumarū rori hei:

- » whakaū i te māmā o ngā rori me ngā tahataha rori, e haumarū tonu ai ina hapa te kaihautū
- » whakapiki ake i tō te hapori mārama ki te paetere me ngā whanonga hautū e haumarū ana
- » akiaki i te whai wāhi atu ki ngā taputapu whakahaumarū waka hei āwhina i te taha ki te ārai tūtukitanga.

Mā te toa takitini e taupā ai te mate, te whara kino rānei o te tangata i ō tātou rori. Tēnā, whāia kia haumarū ai koe, otirā koutou ko ō hoa, ko tō whānau i ō tātou rori.

Mō te raihana hautū

.....

Mō te raihana hautū

Te pūnaha raihana hautū o Aotearoa

Hei aha te raihana hautū?

Ko te pūnaha raihana hautū e whakaū ana i te mātau o ngā kaihautū waka katoa i ō tātou rori ki ngā pūkenga me te mātauranga e hiahiatia ana e haumaruru ai te hautū waka. Kia haumaruru ake ngā kaihautū waka, ka haumaruru ake ō tātou rori.

Ka whakawhiwhia noatia te raihana mō te hautū waka ki te tangata kua puta tana ihu i ngā whakamātautau raihana hautū, kua whakaatu hoki i tana mōhio ki ngā mōtika me te haumarutanga o tangata kē atu.

He mea āwhina te raihana hautū e whai whakaahua ana hei tautohu kaihautū. Ka taea tā te pirihihana tiro tiro mēnā e ū ana ngā tātanga e whai ana i ngā raihana ako me ngā raihana here ki ngā herenga o ō rātou raihana, he āwhina hoki hei whakamau i ngā kaihautū raihana kore, me ērā kua whakakorehia ō rātou raihana.

Kia aronuitia

E ai ki te ture, me mau ki tō raihana hautū ka hautū waka ana koe. Me mātua whakaatu e koe tō raihana ki tētahi āpiha whakaū ina tona koe e ia kia pērā.

He pēhea te āhua o tētahi raihana hautū o Aotearoa?

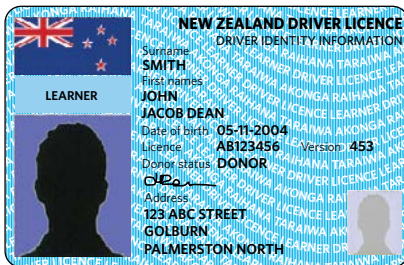

Kei mua o tō raihana ko tō whakaahua me ō taipitopito matawhaiaro.



Kei muri o tō raihana ko ngā momo waka e āhei nei tō hautū, me ngā herenga e hāngai ana.

Ngā herenga raihana

Ina whai herenga tō raihana i tōna tānga, me ū ki aua herenga ka hautū waka ana koe, kei whiua koe ki te tīkiti, ki ngā piro whakawhiu, me tētahi whiunga pūtea.

Ko ētahi o ngā herenga auau, ko te mau whakatika karu ka hautū waka ana, pērā i ngā mōhiti, ko te hautū i te waka nihowhiti aunoa anake rānei, i tētahi waka rānei e motuhake ana ngā panonitanga. Ka hāngai pea tētahi herenga ki tētahi rānei, ki te katoa rānei o ngā kātū e whai nei koe.

Kia mōhio mai: kāore i tō raihana ngā herenga o te raihana ako, o te raihana here rānei. Tirohia ngā herenga o te raihana ako ki te whārangi 15-16, me te raihana here ki te whārangi 19.

Ngā kātū raihana hautū

E ono ngā kātū raihana hautū i Aotearoa. E hāngai ana ia kātū ki ngā momo waka, me ngā momo taumahatanga waka rerekē, he rerekē nō ngā pūkenga e hiahia ana hei hautū i tētahi waka taimaha, i tētahi motupaika rānei, tērā i te motokā noa.

E āhei ai tō hautū motokā, me whai raihana kātū 1.

E toro ki [nzta.govt.nz/what-you-can-drive](https://www.nzta.govt.nz/what-you-can-drive) mō tētahi rārangi o ngā momo waka ka āhei te hautū i ia kātū raihana.

Kātū 1 – Waka noa

Ko ngā kaupupuri i te raihana ako, i te raihana here rānei i te Kātū 1, ka āhei te hautū i:

- » te waka kāore e nui atu i te 4500kg te GLW, te GCW rānei, tae atu ki te tarakihana, ki te waka wāhanga maha, hāunga i te motupaika
- » te kutariki, i te waka tāwhai rānei
- » te wakupuni, i te waka ngaio rānei, e 6000kg, iti iho rānei te GLW, e 4500kg, iti iho rānei te taumahatanga i te rori.

Waihoki, ko te kaupupuri i te raihana here i te kātū 1, ka āhei te hautū i:

- » tētahi tarakihana ahuhenua, e 18,000kg, iti iho rānei te taumaha, mēnā kāore e piki ake i te 40km/h te tere o te haere
- » tētahi tarakihana ahuhenua e tō ana i tētahi tauaru ahuhenua kāore e nui atu i te 25,000kg te taumaha GCW, mēnā kāore e piki ake i te 40km/h te tere o te haere.

Ko ngā kaipupuri i te raihana matua i te kātū 1, ka āhei te hautū i:

- » te waka kāore e nui atu i te 6000kg te GLW, te GCW rānei, tae atu ki te tarakihana, ki te waka wāhanga maha, hāunga i te motupaika
- » te kutariki, i te waka tāwhai rānei
- » te wakapuni, i te waka ngaio rānei, e 6000kg, iti iho rānei te GLW
- » te tokorera* kāore i te nui atu i te 18,000kg te taumaha
- » tētahi waka motuhake* ka rere mā te rango, mā te ara takoto aunoa rānei, ā, 18,000kg, iti iho rānei tana taumaha
- » tētahi waka motuhake* ka rere mā te wīra, ā, e 6000kg, iti iho rānei tana GLW
- » tētahi waka motuhake* ka rere mā te wīra, ā, e 6001-18,000kg tana GLW, mēnā ko te tere:
 - › ko te 40km, iti iho rānei i te hāora, mēnā he waka ahuwhehua e motuhake ana te momo
 - › ko te 30km, iti iho rānei i te hāora, mēnā he momo waka motuhake kē atu
- » tētahi tarakihana, e 6001-18,000kg te GLW, mēnā ko te tere:
 - › ko te 40km, iti iho rānei i te hāora, mēnā he tarakihana ahuwhehua
 - › ko te 30km, iti iho rānei i te hāora, mēnā he momo tarakihana kē atu
- » tētahi tarakihana whai tauaru, e 25,000kg iti iho rānei te GCW, mēnā ko te tere:
 - › ko te 40km, iti iho rānei i te hāora, mēnā he tarakihana ahuwhehua e tō ana i te tauaru ahuwhehua
 - › ko te 30km, iti iho rānei i te hāora, mēnā he momo tarakihana kē atu e tō ana i te tauaru, ā, e whakamahia ana i ngā mahi whakahaere whenua ehara i te ahuwhehua
- » tētahi tauaru ahuwhehua, e 6001-18,00kg te GLW, e whai ana i te whakamanatanga waka motuhake
- » tētahi tarakihana whai tauaru, e 25,000kg iti iho rānei te GCW, e whai ana i te whakamanatanga waka motuhake.

*Me mātua whai whakamanatanga hoki e āhei ai tō hautū i ēnei tū waka.

Kia mōhio mai: ki te hautū tarakihana koe, me mātua whai i te kātū raihana e tika ana mō te taumaha o te tarakihana, engari kāore koe e mate ki te whai whakamanatanga motuhake.

E kapi ana i ngā kātū 2-5 ko ngā taraka me ngā momo waka taimaha. He mōhiohio anō hei tiro tiro māu ki te puka tikanga hautū waka taimaha.

E kapi ana i te kātū 6 ko ngā motupaika. He mōhiohio anō hei tiro tiro māu ki te puka tikanga hautū motupaika.

Ngā whakamanatanga raihana

E haumarū ai te hautū i ētahi momo waka motuhake, te tuku rānei i ētahi momo ratonga, me āta whakangungu koe ki ngā āhuetanga motuhake e hāngai ana. Mā te whakamanatanga raihana i tō raihana hautū e tohu kua tutuki i a koe ngā whakangungutanga, ngā tohu rānei e hiahiatia ana mō taua whakamanatanga.

Anei ngā momo whakamanatanga ka taea, me ngā āheinga e hāngai ana:

Whakamanatanga	E āhei ai tō:
D	hautū i te waka e kawea ana i ngā utanga mōrearea
F	hautū i te tokorera
I	tū hei kaiwhakaako hautū ngaio
O	tū hei āpiha aromatawai kaihautū
P	hautū i te waka ngaio hei kawea pāhihi, hei tauira, ko te pahi, ko te tēkehi, ko te Uber, ko te Ola rānei
R	hautū i te waka momo motuhake e rere ana mā te rango
T	waka momo motuhake e rere ana mā te tauri wīra
V	hautū i te taraka tō
W	hautū i te waka momo motuhake e rere ana mā te wīra

E toro ki nzta.govt.nz/getting-an-endorsement mō ētahi mōhiohio anō.

Me pēhea te whai i tō raihana hautū

E whiwhi ai koe i tō raihana hautū herekore i te Kātū 1, me puta tō ihu i ngā tūārere e toru o te pūnaha raihana hautū:

- » Tūārere 1 - te raihana ako
- » Tūārere 2 - te raihana here
- » Tūārere 3 - te raihana matua

Me mātua tutuki i a koe ngā herenga o ia tūārere, e koke ai koe ki tērā e whai ake ana.

Me mātua puta tō ihu i tētahi whakamātautau ariā, ka tīmata ai koe ki te tūārere 1, arā, ki te raihana ako.

Ngā whakamātautau hautū waka

E rua ngā whakamātautau hautū waka me tutuki i a koe, hei wāhanga o tō whai raihana:

- » Ko te whakamātautau hautū waka mō te raihana here, ko tō raihana here te whāinga.
- » Ko te whakamātautau hautū waka mō te raihana matua, ko tō raihana matua te whāinga.

E toro ki nzta.govt.nz/practical-tests mō ētahi mōhiohio anō.

E hia te utu o tō whai i te raihana hautū, kātū 1?

Te momo tono, whakamātautau rānei	Te nui
Te tono raihana ako	\$48.20
Te whakamātautau ariā mō te raihana ako	\$45.70
Tapeketanga	\$93.90
Te tono raihana here	\$48.20
Te whakamātautau hautū waka mō te raihana here	\$86.60
Tapeketanga	\$134.80
Te tono raihana matua	\$49.60
Te whakamātautau hautū waka mō te raihana matua	\$59.90
Tapeketanga	\$109.50

E kapi ana te GST i ēnei utu katoa, tē āhei hoki te whakahoki utu.

Kia mōhio mai: kāore e kapi ana i tēnei ngā utu mō te mahi anō i te whakamātautau, ki te kore tō ihu e puta i tō nohonga tuatahi. Ki te mate koe ki te mahi anō i tētahi whakamātautau, he utu whakamātautau anō ka pā ki a koe, engari kāore koe e mate ki te utu anō i te utu tono.

Te panoni, te whakakore rānei i tō whakamātautau

He utu atu anō tō te panoni, te whakakore rānei i tō whakamātautau.

Mēnā e rua, neke atu rānei ngā roanga rā mahi i waenga i te rā ka panonihia, ka whakakorehia rānei tō whakamātautau me te rā o taua whakamātautau, ka pā te utu panonitanga ki a koe, \$16.40 tana nui.

Hei whakaea tēnei i te wā me ngā utu e hāngai ana ki te whakakorehia, ki te panonihia rānei o tētahi whakamātautau.

Mēnā he iti iho i te roanga o te rua rā mahi i waenga i te rā ka panonihia, ka whakakorehia rānei tō whakamātautau me te rā o te whakamātautau, kāore he utu panonitanga, engari ka mate koe ki te utu anō i te whakamātautau.

E āhei ana tō tono kia whakahokia te utu whakamātautau tuatahi i utua e koe. Ki te whakakapihia e tangata kē tō wā whakamātautau, ka whakahokia pea tētahi wāhanga o te utu whakamātautau ki a koe, engari he utu hātepe ka tangohia i tērā, \$16.40 tana nui.

Tūārere 1 - te raihana ako

Me mātua whai koe i tō raihana ako, e tīmata ai tō ako ki te hautū i runga rori. Kia whakawhiwhia koe ki tō raihana ako, ka āhei tō timata ki te ako ki te hautū i tētahi motokā, i tētahi waka taimāmā kē atu rānei.

Ko wai e āhei ana ki te tono raihana ako?

Me 16 tau, nui atu rānei tō pakeke, e āhei ai tō tono raihana ako.

Me pēhea te tono raihana ako?

Me haere koe ki tētahi āpiha whakaraihana kaihautū ki te:

- » whakaea i ngā utu o te tono me te whakamātautau
- » whakaoti i ngā herenga o te tono (whārangi 21-24)
- » whakaoti i te whakamātautau ariā, me puta hoki tō ihu i taua whakamātautau.

Te whakamātautau ariā mō te raihana ako

He whakamātautau whiringa-tini tēnei, e 35 ōna pātai, ka mahia mā te rorohiko ki tētahi āpiha whakaraihana kaihautū. E kapi ana i tēnei whakamātautau ko ngā tikanga hautū, ko ngā mōreareatanga, me ngā tukanga e haumaruru ai tō hautū, hei whakaū kei a koe te mātauranga e tika ana e haumaruru ai tō tīmata ki te hautū waka i te rori.

Ka matapōkere te whakaraupapatanga o ngā pātai, ā, ka kōwhiri koe i tāu whakautu e whakapono nei e tika ana. Ka āhei tō panoni i tō kōwhiringa, engari ka rakaina tō kōwhiringa hei tō koke atu ki te pātai e whai ake ana.

Me 32, neke atu rānei ō whakautu tika, e puta ai tō ihu i te whakamātautau. Ki te nui atu i te 3 ō whakautu hē, ka mate koe ki te tāpui i tētahi whakamātautau anō.

Ina puta tō ihu i te whakamātautau, ka whiwhi koe i tētahi raihana ako taupua, ka 21 ngā rā e mana ana, hei whakamahi māu kia tae atu rā anō tō raihana hautū e whai whakaahua ana.

Kia mōhio mai: tēnā, kaua e hari tamariki mai ki tō whakamātautau. Kei whakapōreareatia koe e ngā tamariki i tō taha i a koe, ka hinga ai i te whakamātautau.

Whakarite mō te whakamātautau ariā

Me āta mōhio koe ki ngā tikanga hautū, e puta ai tō ihu i te whakamātautau. Kei te pukapuka nei ngā mea katoa me mātua mōhio e koe.

Hei āwhina i a koe ki te ako i ngā tikanga hautū, kua tāpirihia ētahi pātai nō te whakamātautau ariā ki te pukapuka nei (ki te whārangi 178). E wātea ana hoki ko tā mātou pae tukutuku kore utu, ko Drive, hei ako i ngā wāhanga o te puka tikanga hautū mā ētahi pātai tūturu nō ngā whakamātautau ariā, mā te kēmu me te patapatai anō hoki. E toro ki **drive.govt.nz** mō ētahi kōrero anō.

Ngā matea reo, kōrero ā-waha rānei

Mēnā kua raru tō whakariterite mō tō whakamātautau ariā i runga i tētahi take pānui, i tētahi take reo rānei, he hinonga ka taea pea te āwhina:

» Literacy Aotearoa

waea: 0800 678 910

pae tukutuku: literacy.org.nz

» English Language Partners

waea: (04) 471 7790

pae tukutuku: englishlanguage.org.nz

» Citizens Advice Bureau

waea: 0800 FOR CAB (0800 367 222)

pae tukutuku: cab.org.nz

Ko ngā tāngata e raru ana te pānui ka āhei hoki te tono:

- » kia whakarroatia te wā hei whakaoti i te whakamātautau ariā
- » kia mahi ā-wahatia te whakamātautau ariā

I tua atu i te reo Pākehā, e wātea ana te whakamātautau i ngā reo e whai ake nei:

- » te reo Arepa
- » te reo Kōrea
- » te reo Hainamana
(te whakamāmātanga,
me te reo ōkawa)
- » te reo Punitiapi
- » te reo Kutiarati
- » te reo Hāmoa
- » te reo Hiniti
- » te reo Tonga

Kōrero ki tō āpiha whakaraihana kaihautū mō ētahi mōhiohio anō e pā ana ki ēnei whiringa.

Ngā herenga raihana ako

- » Kaua rā koe e hautū me tō kotahi. Me mātua noho tētahi tētahi kaitirotiro ki tō taha, ki te nōhanga pāhihi o mua (whārangi 19).
- » Mēnā koe e ako ana ki te eke kutariki, kaua rā e pērā i waenga i te 10 karaka i te pō me te 5 karaka i te ata, kaua hoki e kawē pāhihi.
- » Me rite tonu tō whakaatu i ngā pereti L (mā te ākongā hautū) ki tō waka i a koe e hautū ana.
- » Ka āhei tō kawē pāhihi i tō waka, engari me mātua whakaae e tō kaitirotiro. E noho haepapa ana te kaitirotiro ki ngā tāngata katoa i roto i te waka, ki ngā tūāhuatanga katoa hoki ka hua ake i a koe e hautū ana.

He herenga hoki e pā ana ki te waipiro me te hautū waka. Tirohia te whārangi 128 mō ētahi mōhiohio anō.

Ki te whati i a koe ngā herenga ākongā o tō raihana, ka pā pea ki a koe ko te 25-35 piro whakawhiu, me te whiunga ā-pūtea, \$100 te nui.

E toro ki nzta.govt.nz/demerit-points mō ētahi kōrero anō.

Kia aronuitia

Ki te kore koe e ū ki ngā herenga o tō raihana, ka āhei tā te pirihihana aukati i tō hautū waka. Ka whakahaua pea koe kia hoki tōtika ki te kāinga, ka riro rānei ō kī, ka whakakopahia rānei tō waka, ka hūnukutia atu rānei ki tētahi wāhi kāore e noho hei mōreareatanga rori.

Pereti L

Mēnā koe e hautū waka ana i runga i tētahi raihana ako nō te Kātū 1, nō te Kātū 6 rānei, me whakaatu pereti L i tō waka.

Ko tā ngā pereti L, he whakaatu atu ki kaitāwhai kē i te rori he ākongā hautū waka koe, me te āwhina i te pirihihana ki te whakaū mēnā e ū ana te ākongā hautū waka ki ngā herenga o te raihana ako.

Me whai te pereti L i tētahi L pango i mua, he papa kōwhai i muri, kia kua hoki e iti iho i ngā ineitanga e whakaatuhia ana ki te hoahoa i tēnei whārangi.

Mēnā koe e hautū ana i te motokā, i te waka kōperu rānei, i te waka paeuta rānei, me pēnei ō pereti L:

- » me whakaatu i mua, i muri hoki o te waka
- » me mārāma kehokeho te kitea e kaitāwhai kē atu i te rori
- » kia kua hoki e ārai i tō tirohanga whakamua, whakamuri rānei.

Mēnā koe e eke kutariki ana, me whakaatu tō pereti L i muri o tō kutariki.

Ka taea tō hoko rānei i ētahi pereti L ki ngā wāhi āpiha whakaraihana kaihautū, tō mahi rānei i āu anō.

Te ako ki te hautū waka

He haepapa nui te ako ki te hautū waka. He mea nui tō whakawhanake i ō pūkenga hautū, e haumaruru ake ai koe hei kaihautū i ō tātou rori.

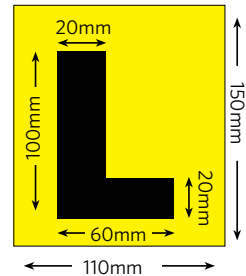

Kia ngaio, kia tūmataiti rānei te whakangungutanga?

Ka āhei tō whai whakangungutanga i tētahi kaiwhakaako hautū ngaio, i tētahi hoa, i tētahi whanaunga rānei ka noho hei kaiako hautū mōu.

He nui ngā tāngata ka tuitui i aua momo e rua, ka nui te whakaharatau tahi me tētahi kaiako hautū, ā, ka whai akoranga hoki i tētahi kaiwhakaako hautū ngaio hei whakawhanake i ō rātou pūkenga.

Te ako ki te hautū waka ki tētahi kaiwhakaako hautū ngaio

Ka tāpae utu te kaiwhakaako hautū ngaio mō ana whakaakoranga, ā, me:

- » whai ia i tētahi whakamanatanga kaiwhakaako hautū ngaio (I) mō ia Kātū raihana e whakaako nei ia
- » noho ki te nōhanga pāhihi o mua i a ia e whakaako ana i a koe.

I mua i tō akoranga tuatahi, tonoa te kaiwhakaako ki te whakaatu taunakitanga ki a koe mō tana whai i te whakamanatanga kaiwhakaako hautū ngaio e tika ana.

Te ako ki te hautū waka ki tētahi kaiako hautū

Ko te kaiako hautū, ko tētahi tangata e mōhio nei koe e whakaae ana ki te whakaako atu i a koe ki te hautū waka. Me whai raihana hautū waka matua ia nō Aotearoa, e mana tonu ana, kāore hoki ōna herenga kaitirotiro, kāore hoki e iti iho i te rua tau e mau ana, tērā rānei ko tētahi raihana hautū nō tāwāhi rānei e hangarite ana.

Ko tō kaiako hautū me:

- » rite tonu te kawae i tana raihana hautū waka i a ia e noho ana hei kaitirotiro i tō hautū waka
- » takatū ki te whakawātea i a ia ki te wā e hiahiatia ana e pai ai tō whakaharatau
- » noho haepapa, me pūkenga, me māia hoki tana hautū waka
- » mātau ki te whakawhitiwhiti kōrero, me te whakamārama i te mōhiohio me te whakaaro kia mārama ai
- » manawanui e whaihua ai te whakaako i a koe
- » taea te whakaako, me te āpiti whakaakoranga anō ki ērā o mua
- » arotake, me aromātai, me aromatawai hoki i tō whanake haere.

Tūārere 2 - te raihana here

Ko wai e āhei ana ki te tono raihana here?

Ka āhei tō tono i tō raihana here hei te wā kua whai koe i ngā pūkenga hautū e hiahia ana e puta ai tō ihu i te whakamātautau raihana here.

Me pēnei koe:

- » me 16½ tau, neke atu te pakeke
- » me whai raihana ako e mana tonu ana
- » kua e iti iho i te 6 marama te roa o tō pupuri i te raihana ako.

Me pēhea taku tono raihana here?

E whiwhi ai koe i tō raihana here, me mātua puta tō ihu i te whakamātautau hautū waka mō te raihana here.

Hei tāpui i te wā o tō whakamātautau hautū waka mō te raihana here, me:

- » toro atu rānei tētahi āpiha whakaraihana kaihautū, ā, ka:
 - › tāpui i tētahi wā hei mahi i te whakamātautau hautū waka mō te raihana here
 - › whakaea i ngā utu o te tono me te whakamātautau
 - › whakaoti i ngā herenga o te tono (whārangi 21-24).
- » me tāpui ā-ipurangi kē rānei i tō whakamātautau hautū waka mō te raihana here. E toro ki nzta.govt.nz/practical-tests mō ētahi mōhiohio anō, me ngā tohutohu mō te tāpui ā-ipurangi.

Mēnā koe ka tāpui ā-ipurangi, me mātua whakaoti i te tukanga tono ki tētahi āpiha whakaraihana kaihautū, e taea ai te tānga o tō raihana hou. Me whakawātea tētahi 30 mēneti, roa atu rānei i mua, i muri rānei i tō whakamātautau, hei mahi i aua mahi.

Tirohia ngā hāora e tuwhera ai te āpiha, i te mea kāore pea e tuwhera i te 30 mēneti i mua i tō wā whakamātautau. Ki te pērā, ka taea tō whakaoti i te tukanga tono i mua i te rā o te whakamātautau, i muri rānei i te whakamātautau.

Ngā herenga raihana here

- » Ka āhei tō hautū waka me tō kotahi, engari kaua i waenga i te 10 karaka i te pō me te 5 karaka i te ata. Ki te hautū waka i waenga i aua hāora, me haere tahi me tētahi kaitirotiro.
- » Ki te whakamātautauhia koe i tētahi waka nihowhiti aunoa mō tō raihana here, ka āhei tō hautū i te waka nihowhiti aunoa anake, ki te kore he kaitirotiro i tō taha.
- » Kāore noa e āhei tō kawē pāhihi, ki te kore he kaitirotiro i tō taha. Ko ngā pāhihi anake ka āhei tō kawē me te kore o tētahi kaitirotiro, ko:
 - › tō hoa rangatira
 - › ngā tamariki e noho tahi ana ki a koe, ka tiakina e koe, e tō hoa rangatira rānei - arā hei matua, hei kaitiaki ōkawa rānei koe, ko tō hoa rangatira rānei ki a rātou
 - › ngā whanaunga e noho tahi ana ki a koe, e whiwhi penihana ana hoki i te karauna
 - › tō matua, tō kaitiaki ōkawa rānei
 - › tētahi tangata e tautiaki nei koe hei kaitiaki matua mōna.

Ki te whati i a koe ngā herenga o tō raihana here, ka whiua pea koe ki ngā piro whakawhiu e 35, me te whiunga ā-pūtea, \$100 te nui.

E toro ki nzta.govt.nz/demerit-points mō ētahi kōrero anō.

He aha te kaitirotiro?

Ko te kaitirotiro, ko tētahi tangata:

- » kei a ia tana raihana hautū waka nō Aotearoa mō tērā kātū waka, kua āta tutuki ngā tūārere katoa, e mana tonu ana
- » kāore he herenga kaitirotiro i tana raihana hautū nō Aotearoa, ā,
- » kāore hoki e poto iho i te rua tau tana pupuri i tana raihana matua nō Aotearoa rānei, i tētahi raihana hautū nō tāwāhi rānei e ōrite ana.

Me rite tonu tana noho i te nōhanga pāhihi o mua, i tō taha, i a koe e hautū waka ana, me kawē hoki e ia ko tana raihana.

Tūārere 3 - te raihana matua

Ko wai e āhei ana ki te tono raihana matua?

Me 18 tau, neke atu rānei te pakeke. Ina tutuki i a koe tētahi o ngā karaehe kaiaka e whakaaetia ana hei whakawhanake pūkenga hautū, ka heke tēnei ki te 17½ tau.

Me mau raihana here koe, e mana tonu ana.

Mēnā kāore anō kia 25 tau tō pakeke, kua puritia e koe tō raihana here mō te:

- » 18 marama, neke atu rānei,
- » 12 marama, neke atu rānei, mēnā kua puta tō ihu i tētahi o ngā karaehe kaiaka e whakaaetia ana hei whakawhanake pūkenga hautū.

Mēnā kua 25 tau, neke atu rānei tō pakeke, kua puritia e koe tō raihana here mō te:

- » 6 marama, neke atu rānei,
- » 3 marama, neke atu rānei, mēnā kua puta tō ihu i tētahi o ngā karaehe kaiaka e whakaaetia ana hei whakawhanake pūkenga hautū.

E toro ki nzta.govt.nz/advanced-driving-course mō ētahi mōhiohio anō mō ngā karaehe kua whakaaetia i tō rohe.

Me pēhea taku tono raihana matua?

E whiwhi ai koe i tō raihana matua, me mātua puta tō ihu i te whakamātautau hautū waka mō te raihana matua.

Hei tāpui i te wā o tō whakamātautau hautū waka mō te raihana matua:

- » me toro atu rānei ki tētahi āpiha whakaraihana kaihautū, ā, ka:
 - › tāpui i tētahi wā hei mahi i te whakamātautau hautū waka mō te raihana matua
 - › whakaea i ngā utu o te tono me te whakamātautau
 - › whakaoti i ngā herenga o te tono (whārangi 21-24).
- » me tāpui ā-ipurangi rānei i tō whakamātautau hautū waka mō te raihana matua. E toro ki nzta.govt.nz/practical-tests

Ki te tāpui ā-ipurangi, me mātua whakaoti koe i te tukanga tono ki tētahi āpiha whakaraihana kaihautū, e taea ai te tānga o tō raihana hou. Me whakawātea tētahi 30 mēneti, roa atu rānei i mua, i muri rānei i tō whakamātautau, hei mahi i aua mahi.

Tirohia ngā hāora e tuwhera ai te āpiha whakaraihana, i te mea kāore pea e tuwhera i te 30 mēneti i mua i tō wā whakamātautau. Ki te pērā, ka taea tō whakaoti i te tukanga tonu i mua i te rā o te whakamātautau, i muri rānei i te whakamātautau.

Ngā herenga o te tonu raihana hautū

Ngā tautohutanga mō te whakaraihana kaihautū

I a koe e tonu ana i ia tūāreke o tō raihana, me whakaatu atu e koe tētahi taunakitanga tuakiritanga e whakaaetia ana.

Ngā taunakitanga o tō tuakiritanga

Me tāpae e koe:

- » tō uruwhenua rānei nō Aotearoa e mana tonu ana,
- » tō raihana hautū rānei nō Aotearoa, e mana tonu ana rānei, kua poto iho rānei i te rua tau e noho mōnehu ana,
- » kia rua o ngā momo tautohutanga e whai ake nei. Me kotahi rawa te pepa matua, me tētahi pepa tautoko. Me taketake ngā pepa katoa, kua ko ngā tāruatanga, ko ngā matawaitanga rānei.

Ngā pepa matua

He uruwhenua nō Aotearoa*

He uruwhenua nō tāwāhi*

He pepa nō Aotearoa mō te haerenga ohotata

He pepa nō Aotearoa mō te haerenga taurewa

He tiwhikete whaiaro nō Aotearoa (he mea tā i raro i te Passports Act, 1992)

He tiwhikete whaiaro nō Aotearoa (he mea tā i raro i te Immigration Act, 1987)

He raihana maupū nō Aotearoa

He tohu whānautanga nō Aotearoa i tāngia i te 1 o Hanuere, 1998, i muri mai rānei

He tiwhikete kirirarau nō Aotearoa

*E whakaaetia ana ēnei pepa ahakoa e mana tonu ana rānei, kua poto iho rānei i te rua tau e noho mōnehu ana. Katoa ērā atu pepa me mana tonu.

Ngā pepa tautoko

He kāri 18+, kāri Kiwi Access rānei

He kāri ratonga hapori

He kāri SuperGold

He kāri Veteran SuperGold

He kāri tautohu tauira nō Aotearoa e whai whakaahua ana

He kāri tautohu kaimahi nō Aotearoa e whai whakaahua ana

He tānga whakaurutanga ki te rārangi kaipōti o Aotearoa

He tau nō Te Tari Taake

He pire ratonga i tāngia i Aotearoa

He raihana hautū nō tāwāhi

He puka 'Steps to Freedom'

Mēnā kāore he whakaahua i ō pepa e rua, me hoatu hoki tētahi whakaahua pērā i ērā mō te uruwhenua kua waitohungia e tētahi kaitaunaki tuakiritanga.

E toro ki nzta.govt.nz/identification mō ētahi mōhiohio anō.

He taunakitanga o te panonitanga ingoa

Mēnā kua panonihia tō ingoa i tērā kua tāngia ki tō raihana, i tētahi rānei o ō taunakitanga tuakiri e rua, ka mate koe ki te tuku atu i tētahi o ngā pepa e whai ake nei hei taunakitanga mō tō panonitanga ingoa. Me taketake aua pepa, me tā hoki i Aotearoa.

- » He tiwhikete mārenatanga, he tiwhikete pākūhā ā-ture rānei.
- » He kape o ngā taipitopito o te mārenatanga, o te pākūhā ā-ture rānei.
- » He tānga ōkawa e mea ana kua tokorau te mārenatanga, te pākūhā ā-ture rānei.
- » He tiwhikete whakakore mārenatanga.
- » He tiwhikete deed poll, he tiwhikete panonitanga ingoa, he tiwhikete whānautanga rānei e whakaatu ana i ngā ingoa e rua.
- » He tauākī ā-ture e whakaū ana i te panonitanga ingoa kua rēhitatia ki te Rārangi Whānautanga, Matenga, Mārenatanga.

Ngā herenga karu

Me mātua whakaū e koe e tika ana te ora o ō karu ka tono ana koe ki ia tūārere raihana.

E tutuki ai tēnei, me:

- » ea rānei i a koe tētahi mātaihanga karu ki tētahi āpiha whakaraihana kaihautū,
- » tāpae rānei e koe tētahi tiwhikete mō te ora o ō karu, tētahi tiwhikete rānei nō te rata, kāore e tawhito ake i te 60 rā.

Me tā tēnei tiwhikete e tētahi kaimātai karu, e tētahi kaiwhakarato hauora rānei kua rēhitatia i Aotearoa. Ko tō rata (arā ko tō 'GP') pea tērā, ko tētahi tapuhi kua rēhitatia rānei, ko tētahi mātanga rānei. Ki te kore e ea i a koe te mātaihanga karu ki te āpiha whakaraihana kaihautū, ka mate koe ki te tāpae tiwhikete kē.

Ki te ora ko tētahi karu anake, ka pāngia pea te whakatau tawhiti. Mēnā kotahi anake tō karu e ora ana, mēnā rānei kotahi anake tō karu, me tāpae e koe tētahi tiwhikete e whakaaetia ana.

Ki te kore e ea i a koe ngā herenga karu, ki te kore rānei koe e tāpae tiwhikete mō te ora o ō karu i mua i te whakamātautau, kāore koe e whiwhi i tētahi raihana taupua - ahakoa puta tō ihu i te whakamātautau, kāore rānei. Ka mate koe ki te whakaea i ngā herenga karu i mua i te tānga o tō raihana hou.

Tauākītanga hauora

Me tika te ora o tō tinana, e āhei ai te hautū waka.

Ka pāngia pea tō hautū waka e ngā tūāhuatanga nei:

- » te matehuka
- » he raru e pā ana ki ō pona, ki ō ringaringa rānei, ki ō waewae rānei
- » he roro ikura
- » he mate maurirere, he mate hinengaro rānei
- » te pēhi kino o te pēhanga toto
- » te mate hukihuki, te hūkiki rānei
- » he wharanga kino - hei whakatauirā, ko te wharanga o te upoko, o te tuarā rānei
- » ngā whakapōreareatanga karu - hei whakatauirā, ko ngā mate arotahi, te tirohanga atarua, te papahewa

- » ngā tūponotanga, ngā mate rānei ki ngā ia roro
- » te mate hirikapo
- » tētahi anō āhuatanga e pāngia ai pea tō āhei ki te hautū waka e haumarua ana.

Mēnā kāore koe e pāngia ana e tētahi o ēnei, ka āhei tō waitohu tauākī e whakaū ana i te pēnā.

Mēnā e pāngia ana koe e tētahi o ēnei āhuatanga, ka mate pea koe ki te whai i tētahi tiwhikete nā te rata.

He whakamōhiotanga mō ngā tiwhikete hauora

Ko ngā tiwhikete hauora, mō ngā take whakaraihana kaihautū:

- » me tānga taketake
- » me tā e tētahi kaiwhakarato hauora kua rēhitatia i Aotearoa - hei tauira, ko tō rata (GP), ko tētahi tapuhi rānei, ko tētahi mātanga rānei
- » kia kaua e roa ake i te 60 rā te tawhito
- » me kī e tika ana tō hauora e taea ai te hautū waka, me āta whakaraupapa rānei i ngā herenga o tō hautū waka.

He rerekē ngā utu mō te tiwhikete hauora. Māu tonu aua utu e pīkau.

Tonoa tētahi '*Medical certificate for driver licence*' - he kape kei tō kaiwhakarato hauora.

Te tuku whēkau

Ka whakakī ana koe i tō puka tono mō te raihana hautū, ka uia koe ki te pātai nei:

Ka whakaae rānei koe kia tukuna atu ō whēkau, ka mate ana koe?

Ina tohu koe i te pouaka 'Yes', e tohu ana koe i tō hiahia ki te tuku atu i ō whēkau, i ō pūtautau, ā, ka tāngia te kupu 'Donor' ki tō raihana hautū. Ka āta tuhia hoki tērā ki tō rēhitatanga i te rārangi raihana hautū.

Ka mātua tonoa te whakaaetanga a tō whānau i mua i te tangohanga whēkau, pūtautau rānei hei tukuhanga atu, nō reira me tino kōrero tō whakatau i waenganui i a koutou ko tō whānau. He whakaaro pai kia āta whakaarotia te tukuhanga whēkau i mua i tō haere ki te āpiha whakaraihana kaihautū.

E toro ki **donor.co.nz**, me whakapā atu rānei ki a Organ Donation New Zealand ki 0800 4 DONOR (0800 436 667) mō ētahi mōhiohio anō.

He mōhiohio anō mō te raihana

Te whakahou i tō raihana hautū

E whakaatuhia ana i tō raihana ko te rā e mōnehu ai ngā kātū o tō raihana. Ki te hiahia koe ki te hautū waka tonu whai muri i taua rā, me whakahou tō raihana.

Ka tuku atu mātou i tētahi reta whakamaumahara mō te whakahoutanga i tōna ono wiki i mua i te rā mōnehu o tō raihana. He puka tonu whakahoutanga i ngā āpiha whakaraihana kaihautū katoa hei tiki māu, e toro rānei ki nzta.govt.nz/form-dl1

E toro ki nzta.govt.nz/renewing-your-licence mō ētahi mōhiohio anō.

Mēnā koe e whakahou ana i tō raihana hautū i muri i tō huritau 75, me tāpae e koe he tiwhikete hauora, ā, mēnā e tūtohungia ana e tō rata, me ea i a koe tētahi whakamātautau mō te haumarutanga i runga rori.

E toro ki nzta.govt.nz/renewing-over-75 mō ētahi mōhiohio anō.

Te whakakapi i tētahi raihana kua ngaro, kua tāhaetia rānei, kua pakaru rānei

Mā te whakakapi wawe i tō raihana kua ngaro, kua tāhaetia rānei, ka iti iho te tūraru ka whānakohia te tuakiri.

E āhei ana tō tono kia whakakapihia tō raihana ki tētahi āpiha whakaraihana kaihautū, mēnā rānei he tuakiri RealMe tāu kua whakaūngia, ka āhei pea tō tono ā-ipurangi. Mēnā kāore e taea e koe tētahi o ēnei, whakapā mai ki a mātou hei whakakore i tō raihana.

E toro ki nzta.govt.nz/replacing-your-licence mō ētahi mōhiohio anō.

Ngā kaihautū nō tāwāhi

Mēnā he raihana tōu nō tāwāhi e mana tonu ana, e hāngai ana hoki, ka āhei pea tō hautū waka mō te 12 marama i muri i te rā o tō taenga whakamutunga ki Aotearoa nei.

E toro ki www.nzta.govt.nz/new-residents-and-visitors mō ētahi mōhiohio anō.

Te whakawhiti ki tētahi raihana kātū 1, kātū 6 rānei nō Aotearoa

Mēnā he raihana tōu nō tāwāhi e mana tonu ana, e hāngai ana hoki, ka āhei pea te whakawhiti hei raihana nō Aotearoa.

E toro ki www.nzta.govt.nz/new-residents-and-visitors mō ētahi mōhiohio anō.

Ngā whakaaetanga hautū mō tāwāhi

Mēnā he raihana hautū tōu nō Aotearoa, ā, e hiahia ana koe ki te hautū waka ki whenua kē, e tūtohutia ana ko tētahi whakaaetanga hautū mō tāwāhi, e kīia ana i te reo Pākehā he 'international driving permit' (IDP) mō te nuinga o ngā whenua i tāwāhi. Tirohia te pae tukutuku a te New Zealand Automobile Association (AA) mō te rārangi o nāiane.

Kia mōhio mai: ehara te IDP i te raihana hautū - he whakamāoritanga o tō raihana hautū ki reo kē, ā, me kawe tahi me tō raihana e āhei ai tō hautū waka i whenua kē i raro i ō rātou ture. Ko te kotahi tau te mōrahi e mana tonu ai tō IDP i te rā o tana tānga. Ka taea tō tonu IDP mā te AA.

E toro ki aa.co.nz/idp mō ētahi kōrero anō.

Te haere ki tāwāhi

Whakaūngia te rā mōnehu o tō raihana mēnā koe ka hautū waka i tāwāhi, i te mea tē āhei te whakahoutanga o tō raihana nō Aotearoa i tāwāhi.

Ki te ngaro, ki te tāhaetia rānei tō raihana i a koe i tāwāhi, e āhei ana tō tonu whakakapi.

E toro ki nzta.govt.nz/kiwis-overseas mō ētahi mōhiohio anō.

Mō ngā tohu

Mō ngā tohu

Ākona ngā momo tohu matua i ngā rori me ngā waka ka kitea e koe i ngā rori o Aotearoa.

He tohu kē atu ka kōrerotia i ngā wāhanga o te pukapuka nei e hāngai ana.

Ngā momo tohu matua

Ko te nuinga o ngā tohu ka kitea i ō tātou rori he tohu waitohu nō tāwāhi. Nō reira ka rite tonu ngā hanga me ngā tohu ki ērā ka kitea hei tohu rori huri noa i te ao.

Ka whakamahia te tohu waitohu nā te māmā me te tere ki te pānui, ki te whai māramatanga anō hoki.

Ko te nuinga he mea hanga ki te papanga whakaataata, kia māmā ai te pānuihia i te pō.

Ngā momo tohu e toru

Ka taea te wāwāhi ngā tohu i ō tātou rori kia toru ngā momo:

- » ko ngā tohu here
- » ko ngā tohu whakatūpatō
- » ko ngā tohu whakamōhio.

Me mātua mōhio koe, me mārama hoki ki ia momo tohu.

He tauira o ēnei tohu e whakaatuhia ana i ngā whārangi e whai ake nei.

Kia mōhio mai: he kohinga whāiti noa iho tēnei o ngā tohu waitohu e whakamahia ana i ō tātou rori. Hei whakawaia tēnei i a koe ki ngā momo tohu matua e toru, tērā i te whakaatu atu i ngā tohu katoa ka kitea e koe ka hautū waka ana.

Ngā tohu here

Mā ngā tohu here koe e mōhio ai ki ngā mea me mātua mahi e koe, me karo rānei e koe. He whero, he kikorangi rānei te nuinga.



Huri whakatematau



Haere tika tonu atu



Kia ū ki te taha mauī



Kaua rā e tere ake i te 50km/h



Kaua rā e kuhu ki te rori nei



Kaua rā e huri whakatemauī



Kaua rā e huri whakamuri



Me tū, ka tautuku ai



Me whakapōturi, ka tautuku ai (ka tū rānei, mēnā e tika ana kia pērā)



Tūtei ā-kura - me tū

He taitapa whero ō ētahi tohu here.



KEEP LEFT
UNLESS
PASSING

Kia ū ki te taha mauī,
hāunga rā te tohipa



He ara pahi e āhei ai
hoki ko te pahikara, ko te
motupaika, me te kutariki



He ara pahi mō te pahi
anake



He ara herenga motuhake - hei whakamahi mā ngā waka
ngaio hei kawē pāhihi, mā te pahikara, mā te motupaika, mā
te kutariki, me ngā waka e kawē ana i te nui o ngā tāngata
e tohua ana ki te tohu, nui atu rānei. Ko T2 e mea ana kia
tokorua, nui atu rānei, ko T3 e mea ana kia tokotoru, nui atu
rānei.

Kia aronuitia

He tikanga motuhake pea ā ngā mana rori, pērā i te kaunihera ā-rohe,
e hāngai ana ki ngā kaitāwhai i te rori i ētahi wāhi whāiti. Me whakaatu
ēnei herenga mā ngā tohu, mā ngā tānga rori rānei.

Ngā tohu whakatūpatō

Mā ngā tohu whakatūpatō koe e whakamataara ki tētahi mōreareatanga i te rori i tua atu rā. Hei whakatonu ēnei i a koe kia tūpatō e haumarū ai ko koe, ko ngā kaitāwhai kē atu rānei i te rori, ko ngā kaimahi rori rānei e tautiaki ana i ngā rori.

E rua ngā momo tohu whakatūpatō:

- » Ko ērā e whakatūpatō i a koe ki tētahi mōreareatanga pūmau.
- » Ko ērā e whakatūpatō i a koe ki tētahi mōreareatanga taupua.

He taimana te hanga o te nuinga o aua momo tohu e rua.

Ngā whakatūpatō pūmau

He kōwhai me te pango ēnei tohu whakatūpatō.



He whakawhitinga
waihiko



Kia mataara ki te tamariki



He papa retireti



He whakawhāititanga
rori



He whakatūpatō wawe
ki te tepenga teitei

Ngā whakatūpatō taupua

He karaka me te pango ngā tae o ngā tohu whakatūpatō nei.



He mahinga rori



Kua kati te ara



He papa kirikiri



Me tū ka tonoa ana



He paheketanga



He mōreareatanga kē atu

CHECKPOINT

POLICE OPERATION

He tohu reorua

Waihoki, ka kitea pea he tohu reorua i te reo Māori me te reo Pākehā.

KURA
SCHOOL

He tohu kura

Ngā tohu whakamōhio

He mōhiohio whaitake i ngā tohu nei, hei tauira, ko te tawhiti ki te tāone e tūtata mai nei. He tapawhā hāngai te hanga o te katoa, engari he maha ngā tae, ngā rahinga rerekē anō hoki.



Ka āhei te huri whakatemauī, engari me mātua tautuku ki te waehikoī me ngā waka kē atu

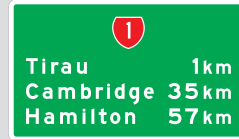

E whakaatu ana i te nama o te ara matua me te tawhiti ā-kiromita ki ngā wāhi kua whakarārangihia

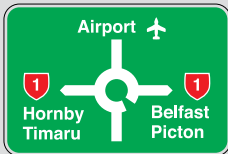

E whakaatu ana i ngā tūtohutanga ki wāhi kē atu i te pūtahi i tua atu nei



E whakaatu ana i te nama o te ara matua me ngā tūtohunga ki ngā wāhi ka whakarārangihia



E whakaatu ana i te ara ki te pūnga mōhiohio e tūtata ana



Ngā tohu whakamōhio taupua - ko ngā mahinga rori, ko te tomokanga rānei ki te wāhi waihanga ka 100 mita ki tua

Ngā tohu waka

Me whai tohu ko ngā waka whakahara me ngā waka e tino kaitā ana te utanga. He waka ārahi hoki pea ōna hei whakatūpatō i ngā kaitāwhai kē atu i te rori kia mataara.

Ina kite koe i tētahi tohu pēnei, i tētahi waka ārahi pēnei rānei i a koe e hautū waka ana, me whakapōturi tō haere. Ki te ahu pēnā atu te waka whakahara, te utanga nui rānei ki a koe, ka mate pea koe ki te neke ki te taha, ka tū ai, kia tohipa rā anō taua waka. Arohia ngā tohutohu a te kaihautū o te waka ārahi, ka pupuri pea i tētahi tohu STOP/SLOW, i tētahi tohu whero hei whakahaere waka, i tētahi haki whero rānei.

Ngā tohu OVERSIZE

Ka kitea te tohu ki te waka whakahara. Ina kite koe i te tohu nei ka hautū waka ana koe, āta haere kia tohipa atu rā anō taua waka. Ka kaitā rawa atu pea te waka, nō reira tukua kia nui te wāhi ki a ia i te rori.

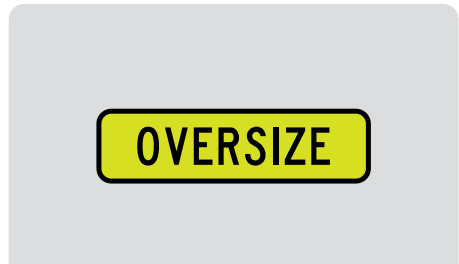

Ngā waka ārahi

Ki te nui te utanga o tētahi waka, ka haere tahi pea me tētahi waka ārahi, he rama karaka ōna e raparapa ana me tētahi tohu i tōna tuanui, hei whakatūpatō i kaitāwhai kē atu i te rori.

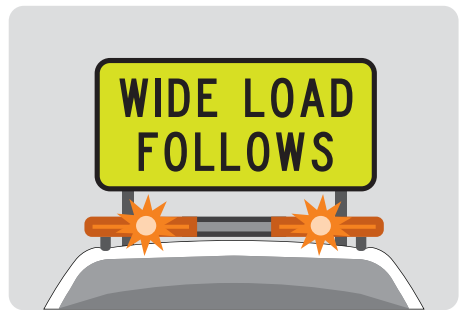

He utanga tino nui

Ki te tino nui te utanga o tētahi waka, ka rua ngā waka ārahi ka haere i mua i a ia.

He rama rarapa ō te waka ārahi tuatahi, he karaka me te waiporoporo ngā tae, me tētahi tohu i tana tuanui e mea ana '**Danger slow down**'.



Mēnā kei mua te waka ārahi i te utanga, ko **'Long load follows'**, ko **'Wide load follows'** rānei te kōrero i te tohu.

Mēnā kei muri te waka ārahi i te utanga, ko **'Long load ahead'**, ko **'Wide load ahead'** rānei te kōrero i te tohu.

He rama rarapa ō te waka ārahi tuarua, he karaka te tae, me tētahi tohu i tana tuanui e mea ana **'Wide load follows'**.



Kia aronuitia

Ina kite koe i tētahi tohu 'oversize', i tētahi waka ārahi rānei e raparapa ana ngā rama, whakapōturihia tō haere, kia takatū hoki koe ki te neke ki te taha, ka tū ai. Arohia ngā tohutohu a te kaihautū o te waka ārahi.

DRIVE

Kia rawe tō hautū i Aotearoa

**Ko Drive tētahi
taputapu matihiko
kore utu hei
āwhina i a koe:**

E māia ai te puta o
tō ihu i tō
whakamātautau,
me tō hautū waka i
Aotearoa

drive.govt.nz

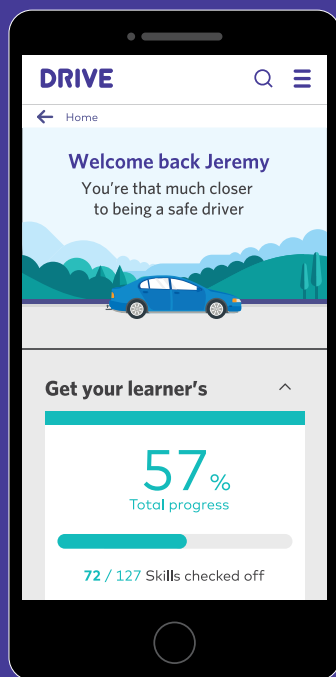

DRIVE

Te Kāwanatanga o Aotearoa
New Zealand Government

Mō te hautū waka

Mō te hautū waka

Ngā pūkenga hautū matua

Ākona ngā pūkenga hautū matua me ngā tikanga hautū e hiahiatia ana, e haumaruru ai, e matatau anō ai koe hei kaihautū waka.

Te ū ki te taha mauī

Haere ai ngā waka i te taha mauī o te rori i Aotearoa.

Ki te kore koe e ū ki te taha mauī, he nui te tūpono ka hua i a koe he tukinga ihuwaka. Koinei tētahi o ngā momo tukinga kino katoa, inā hoki ko te mate, ko te wharanga kino rānei te hua i te nuinga o te wā.

Te ū ki te taha mauī i ngā rori whai ara

He ara ō te nuinga o ngā rori i Aotearoa, ka tohungia ki te rārangi mā, ki te takiruatanga rārangi mā rānei, ki te ira koutu rānei.

Ka hautū ana i te rori whai ara, he mea nui kia ū tonu tō waka ki tō ara.

Mēnā e rua, nui atu rānei ngā ara i tō taha o te rārangi waenga:

- » kia rite tonu tō ū ki te ara mauī, i ngā wā ka taea
- » kua e noho i te ara e pātata katoa ana ki te rārangi waenga mēnā mā te pērā e taupāngia ai te rere o waka kē atu.

Me whakamahi noa te ara e pātata katoa ana ki te rārangi waenga mēnā:

- » e hiahia ana koe ki te tohipa i waka kē atu
- » e hiahia ana koe ki te huri whakatematau
- » kua kapi katoa te ara mauī i te waka, kua aukatingia rānei.

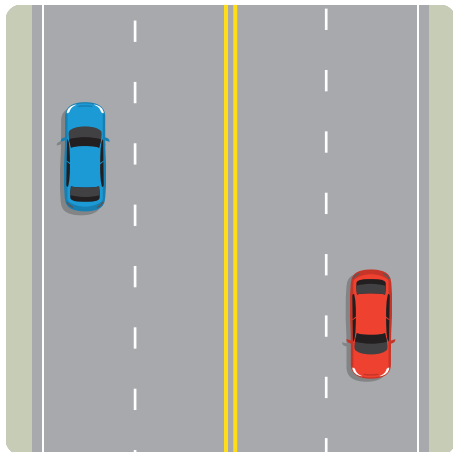

Te ū ki te taha mauī i tētahi rori ara-kore

Ko te rori ara-kore ko tētahi rori karekau ōna rārangi mā, karekau rānei ōna ira koutu.

E noho tawhiti ai koe i ngā waka e ahua ana ki a koe, kia kaha te ū ki te taha mauī o te rori i ngā wā katoa ka taea.

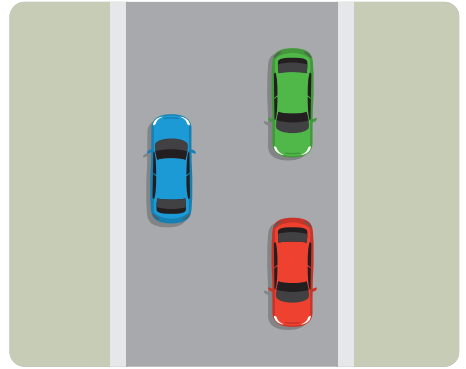

Te ū ki te taha mauī i tētahi kōpiko

Kia ū ki te taha mauī ka haere ana koe i tētahi kōpiko, i tētahi hurihanga rānei i te rori, ahakoa kei tētahi rori whai ara, kei tētahi rori ara kore rānei koe e haere ana.

Me pēnei nā te mea tē kitea he aha rā kei tua o te koki i ngā wā katoa. Me takatū koe ki te whakapōturi i tō haere mō te tūpono he kaieke pahikara, he hōiho, he waehīkoi, he mea kē atu rānei kei tō taha o te rori, tae atu hoki ki ētahi waka kē atu e ahua ana ki a koe.

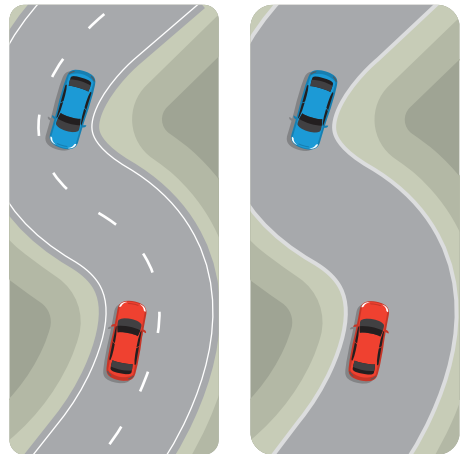

He aha te rori?

He tino whānui te whakamāramatanga ā-ture ki te rori. E kapi ana i a ia ko te rori tonu, tae atu anō hoki ki ngā wāhi katoa e wātea ana hei toro mā te hunga tūmatawhānui - pēnei i ngā taha moana, i ngā tahataha awa, i ngā whaiawa, i ngā papa hākinakina, i ngā tūnga waka, i ngā whenua tāpui, i ngā wāpu me ngā tahataha rori.

Nō reira, ka mau tonu ko ngā momo here pēnei i te whakaatu i tētahi tohu whakamana waka (warrant of fitness/WoF) e mana tonu ana, i te mau raihana hautū waka e mana tonu ana, i te mau tātua, me te aro ki ngā tikanga hautū, ahakoa e hautū waka ana koe i wāhi kē atu i te rori.

Te tūtohu

Ko tā ngā tūtohu he whakamōhio i ngā kaitāwhai kē atu i te rori e panoni ana koe i tō ahunga, i tō tūranga rānei i te rori. He wāhanga nui o te hautū waka kia haumarua ai, ko te mōhio mō āhea tūtohu ai, me pēhea hoki te pērā.

I te nuinga o te wā, ka tūtohu ngā kaihautū mā te whakamahi i ngā rama tūtohu. Heoi, he wā ōna ka mate pea koe ki te tūtohu ā-ringa mēnā kāore e mārama te kitea o ō rama tūtohu.

Mō āhea tūtohu ai

Me mātua tūtohu mō te 3 hēkena, roa atu rānei, i mua i tō:

- » huri whakatemauī, whakatematau rānei
- » neke whakatemauī, whakatematau rānei - hei tauira, ka whakawhiti ana ki ara kē
- » whakatū i te waka, i tō whakapōturi rānei i tō haere
- » puta:
 - › i tētahi tūranga waka
 - › ki te tohipa i tētahi atu waka
 - › ki te whakawhiti ki ara kē atu.

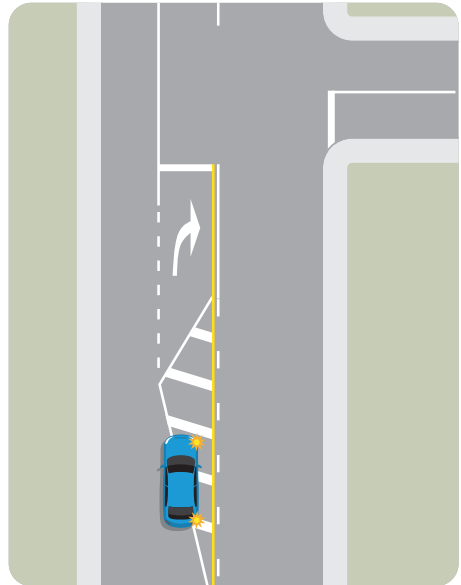

Tirohia te whārangi 82 mō ētahi mōhiohio anō e pā ana ki te tūtohu i ngā pūtahi protaka.

Te whakamahi i ngā rama tūtohu

Arā atu anō ētahi tūtohu ka whakamahia e ngā kaitāwhai i te rori hei whakawhitiwhiti kōrero ki a koe. Me mātua mōhio koe he aha rawa ēnei tūtohu, ka mutu, me aha ina kitea tētahi e koe.

Kia aronuitia

Kei pōhēhē koe kua kitea ō tūtohu e kaihautū kē atu.

Whakamahia te rama tūtohu **mauī**:

- » ka huri whakatemauī ana
- » ka neke whakatemauī ana - hei taura, i a koe e hoki ana ki te ara mauī ka mutu ana te tohipa, ka hoki ana rānei ki te taparori.



Te rama tūtohu mauī

Whakamahia te rama tūtohu **matau**:

- » ka huri whakatematau ana
- » ka neke whakatematau ana - hei taura, i a koe e puta ana i tētahi tūranga waka.



Te tūtohu ā-ringa mō te huri whakatematau



Te rama tūtohu matau



Kia aronuitia

Kei whakawhirinaki noa ki ngā tūtohu a kaihautū kē atu. E pōturi haere ana rānei te waka? Kei te wāhi tika o te rori te waka e ai ki te tūtohu?

Te whakatū i te waka

Mā ngā rama tumu, arā mā ngā rama whero kei muri o tō waka, e mōhio ai te hunga i muri i a koe e whakapōturi ana, e whakatū ana rānei koe i tō waka. Ka aunoa te kā mai o ngā rama tumu ka whakamahia ana te whakatumu. Kia mau tō wae ki te whakatumu e kā tonu ai te rama tumu hei whakatūpatō i ngā kaihautū kē atu.



Te tūtohu ā-ringā mō te whakatū, mō te whakapōturi rānei i te waka



Ngā rama tumu

Hei āwhina: mā te patō i te whakatumu e raparapa ai ngā rama tumu hei whakatūpatō i ngā kaihautū kē atu.

Ngā rama mōreareatanga

Ka whakakāngia ana e koe ō rama mōreareatanga, ka raparapa ngātahi ngā rama tūtohu e rua hei whakatūpatō i ngā kaitāwhai kē atu i te rori. Me whakakā ō rama mōreareatanga ina huri tō waka hei mōreareatanga rangitahi mō ngā kaitāwhai kē atu i te rori, pērā i ngā wā:

- » e panoni taea ana koe i te tahataha rori
- » kua raru tō waka, ā, e tōia atu ana.

He tūtohu kē atu

Arā atu anō ētahi tūtohu ka whakamahia e ngā kaitāwhai rori hei whakawhitiwhiti kōrero ki a koe. Me mātua mōhio koe he aha rawa ēnei tūtohu, ka mutu, me aha ka kitea ana e koe.

Ngā rama rarapa me ngā tangi whakatūpato

Mēnā e ahu ana tētahi waka ohotata ki a koe, pēnei i te waka tūroro, i te waka patu ahi, i te waka pirihihana rānei, e whai ana rānei i a koe, ka mutu e rangona ana ngā oro whakamataara, e raparapa ana rānei ngā rama, he whero, he kikorangi, he whero me te kikorangi rānei ngā tae, me neke tō waka ki te taha, ā, mēnā e tika ana kia pērā, me whakatū tō waka ka tuku ai i te waka ohotata kia tohipa.

Mēnā he waka pirihihana e whai ana i a koe, ā, e rangona ana tana oro whakamataara, e raparapa ana rānei ana rama, me wawe te neke ki te taha ka whakatū ai i tō waka.

Ka tonoa ana, me mātua tuku e koe ki tētahi pirihihana ko:

- » tō ingoa, tō wāhitau, me te rā i whānau mai ai koe
- » tō raihana hautū waka
- » te ingoa o te tangata nōna te waka.

Mēnā e whai ana tētahi waka i a koe, he rama kikorangi e raparapa ana, me wawe te neke ki te taha, ka whakatū ai i tō waka. He mea whakamahi ngā rama kikorangi e raparapa ana e ngā āpiha mō te mana ārai, te kaimoana me te taiāpure. Kei ngā āpiha nei te mana ki te whakatū waka.

Ka whakamahi pea ngā rata, ngā nēhi, ngā tapuhi rānei i tētahi rama rarapa, he kākāriki te tae, e titia ana ki te tuanui o te waka mō ngā take mahi ohotata. Ina kitea ēnei rama, me mātua neke koe ki te taha ka tuku ai i te waka kia tohipa.

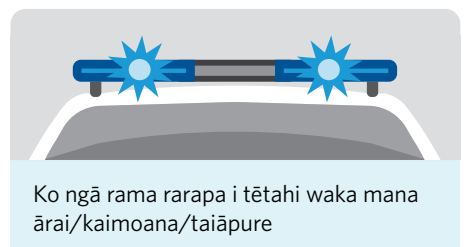
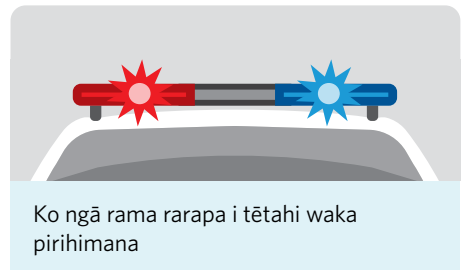
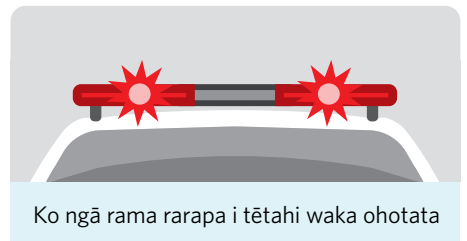

Ka raparapa ana ngā rama tahetoka i ngā waka ratonga, pēnei i ngā taraka tō me ngā waka tautiaki rori, hei whakatūpato tērā i a koe ka pātata atu ana ki te waka rā. Ka kitea ana ēnei rama, me whakapōturi tō haere, me takatū hoki ki te whakatū i tō waka mēnā e tika ana kia pērā.

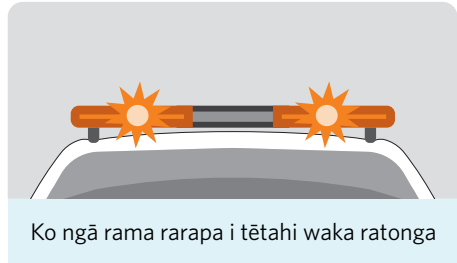

Ka whakamahi pea ngā waka whakahara i ngā rama tahetoka e raparapa ana, ā, ka whakamahi pea ngā waka ārahi i ngā rama tahetoka, i ngā rama waiporoporo rānei e raparapa ana. Ka mate pea koe ki te neke ki te taha, ki te whakatū rānei i tō waka kia tuku ai i te waka kia tohipa. Tirohia ngā whārangi 34-35 mō ētahi mōhiohio anō mō ngā waka whakahara.



Ko ngā tūtohu whero e raparapa ana i waho atu o tētahi whare patu ahi, o tētahi taunga rererangi rānei e tohu ana me mātua whakatū tō waka, ka mutu me tū tonu kia mutu rā anō te raparapa o ngā rama.

He pirihihana e tohutohu ana i ngā waka

Ka tohutohu ana tētahi pirihihana i ngā waka, me mātua whakatū tō waka, me whai rānei i ngā tohutohu a te āpiha. Ka noho mātāmua ngā tohutohu a tētahi pirihihana ki:

- » ngā rama pūtahi
- » ngā tohu rori
- » ngā tikanga tautuku.

Mēnā e whakahaere ana tētahi pirihihana i tētahi pūtahi, me āta whai kia hou atu ki te ara e tika ana. Ki te kore, ka mate pea koe ki te peka ki wāhi kē.

Whakamōhiotia te āpiha ki tō ahunga mā te whakamahi i ō rama tūtohu.

Te huri

I ōna wā, he mahi mōrearea te huri, inā hoki he nui tonu ngā wā ka mate koe ki te whakawhiti i te ahunga o waka kē atu. Kia mahara - i te nuinga o te wā, ka tautuku ngā waka e huri ana ki ērā kāore i te huri.

Me pēhea e huri ai

E tika ai ā-ture nei, e haumaruru ai hoki te huri whakatemauī, te huri whakatematau rānei:

- » me āta tirotiro mēnā rānei he waka atu anō kei mua, kei muri, kei ngā tahataha rānei
- » kei wareware ki te tiro ki tua o tō pokohiwi, ki ō whaitua huna, arā, ko ngā wāhi i te rori kei ngā tahataha o tō waka, tē kitea i ō whakaata
- » kia mataara ki te waehīkoi
- » me tūtohu mō te 3 hēkena, roa atu rānei
- » me huri, ka haumaruru ana.

Mēnā e huri whakatemauī ana, whakamahia te tūtohu mauī. Mēnā e huri whakatematau ana, whakamahia te tūtohu matau.

Kia takatū ki te whakatū i tō waka, ahakoa pea e tika ana kia tautuku tērā atu kaihautū ki a koe.



Kia aronuitia

Me tirotiro ngā whaitua huna ka huri ana, ka whakawhiti ana rānei ki ara kē atu.

Te huri atu i tētahi ara urunga

Mēnā koe e puta ana i tētahi ara urunga:

- » me whakapōturi tō haere, ka tū ai ki te pito o te ara urunga
- » me āta tirotiro mēnā rānei he waehīkoi, he waka, he mōreareatanga atu anō rānei kei te rori me te ara hīkoi
- » me tautuku ki:
 - › te tangata e whakamahi ana i te ara hīkoi
 - › te kaieke pahikara e haere ana mā tētahi ara pahikara
 - › ngā waka i te rori, tae atu ki ngā waka e huri whakatematau ana ki te ara urunga.

Te huri whakatemauī

Mēnā koe e huri whakatemauī ana ki tētahi anō tiriti, ki tētahi ara urunga rānei:

- » me noho ki te ara huri whakatemauī, me ū rānei ki te taha mauī o te rori
- » me whakapōturi tō haere i mua i te huringa
- » me tiro ngā whakaata, me tiro whakamuri hoki ki tua o tō pokohiwi mauī kia kitea ai ngā whaitua huna
- » me tūtohu mō te 3 hēkena, roa atu rānei
- » e huri, ka haumarua ana.

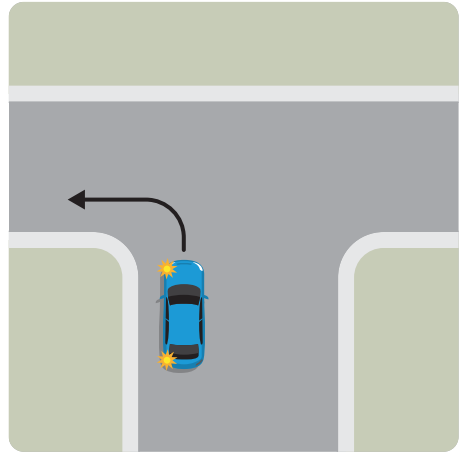

Te ū ki te taha mauī i tētahi rori ara-kore

Ko te rori ara-kore ko tētahi rori karekau ōna rārangi mā, karekau rānei ōna ira koutu.

E noho tawhiti ai koe i ngā waka e ahua ana ki a koe, kia kaha te ū ki te taha mauī o te rori i ngā wā katoa ka taea.

Kia aronuitia

Ka huri ana, me ū ki tō tūranga i te rori.

Hei tauira, mēnā koe kei te taha mauī o te rori, me ū ki te taha mauī o te rori, whai muri i te huringa, ā, mēnā koe kei te ara i te taha o te rārangi waenga, me huri ki te ara kei te taha o te rārangi waenga.

Te huri whakatematau i tētahi rori ara-kore

I tēnei horopaki:

- » me whakapōturi tō haere i mua i te huringa
- » me tiro ngā whakaata, me tiro whakamuri hoki ki tua o tō pokohiwi matau kia kitea ai ngā whaitua huna
- » me tūtohu mō te 3 hēkena, roa atu rānei
- » whakatata atu ki te rārangi waenga ka whakarite ai i tō waka mō te huringa
- » me tiro anō ngā whakaata, ka tiro whakamuri ai ki tua o tō pokohiwi matau kia kitea ai ngā whaitua huna
- » e huri, ka haumarua ana.

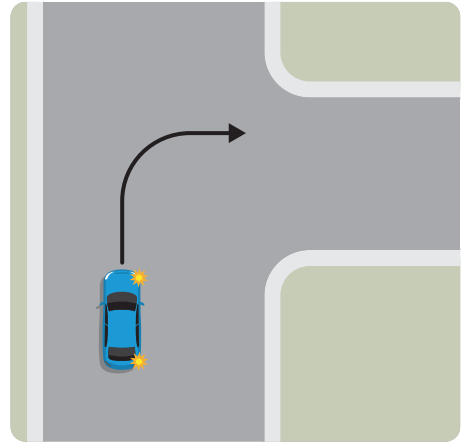

Te huri whakatemalaū i tētahi rori whai rārangi waenga

I tēnei horopaki:

- » me whakapōturi tō haere i mua i te huringa
- » me tiro ngā whakaata, me tiro whakamuri hoki ki tua o tō pokohiwi matau kia kitea ai ngā whaitua huna
- » me tūtohu mō te 3 hēkena, roa atu rānei
- » whakatata atu ki te rārangi waenga ka whakarite ai i tō waka mō te huringa
- » me tiro anō ngā whakaata, ka tiro whakamuri ai ki tua o tō pokohiwi matau kia kitea ai ngā whaitua huna
- » e huri, ka haumarua ana.

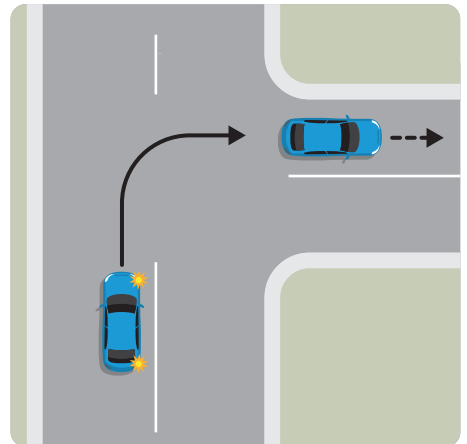

Te huri whakatematau i te taha mauī o te rori

Mēnā e tere ana te rere o ngā waka kē atu, e pātata rawa ana rānei te whai i a koe, mēnā rānei e whāiti ana te rori, ko te painga atu pea kia tatari ki te taha mauī o te rori kia pai rā anō te huri, tēnā i te tū ki waenga i te rori, ka whakapōturi ai i ngā waka.

I tenei horopaki:

- » me tūtohu whakatemauī mō te 3 hēkena, roa atu rānei
- » me tiro ngā whakaata, me tiro whakamuri hoki ki tua o tō pokohiwi matau kia kitea ai ngā whaitua huna
- » neke atu ki te taha mauī o te rori
- » me tatari ki reira kia haumarū rā anō te huringa
- » me tūtohu whakatematau mō te 3 hēkena, roa atu rānei, i mua i te huringa
- » me tiro anō ngā whakaata, ka tiro whakamuri ai ki tua o tō pokohiwi matau kia kitea ai ngā whaitua huna
- » e koke, ka haumarū ana.

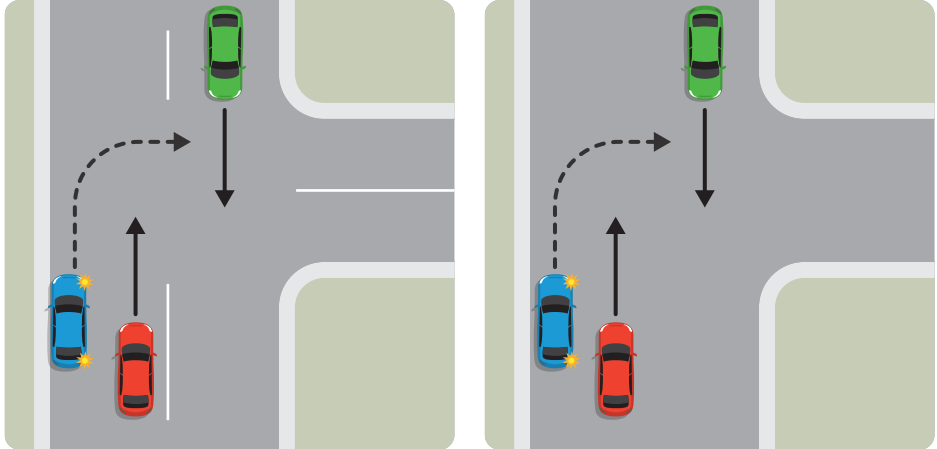

Mēnā kua tū hoki tētahi waka i mua i a koe kia huri whakatematau ai, ko te painga atu kia tatari ki muri i taua waka, ka huri atu ai i taua tūranga tonu. Kia tūpatō i ngā rori e tere ana te rere o ngā waka.

Te huri whakatematau i tētahi taiwhanga huri whakatematau

Ko te taiwhanga huri whakatematau ko tētahi wāhi ki reira rā tatari ai ngā waka e huri whakatematau ana kia haumaruru rā anō te pēnā, tē whakapōturi ai i ngā waka e ahu tōtika atu ana.

Kāore e āhei tō whakamahi i te taiwhanga huri whakatematau kia tohipa ai i tētahi waka e ahu tōtika atu ana.

Ka whakatata atu ana koe ki te taiwhanga huri whakatematau, ka kitea kua peitahia te rori ki tētahi tapatoru mā, he rārangi hauroki i waenga, ka whai ko tētahi pere huri whakatematau kotahi, nui atu rānei.

E āhei noa ana tō hautū i runga i ngā rārangi hauroki mā mēnā koe e huri whakatematau ana.

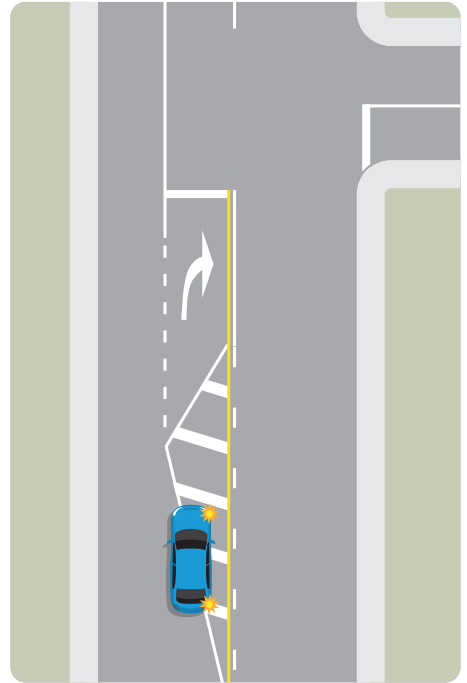

He kupu āwhina e haumaruru ai te huringa

Mēnā kua tū koe e pai ai te huri whakatematau, me anga whakamua tonu ngā wīra o tō waka kia tīmata rā anō te huri. Mā te pēnā, ki te tukia koe mā muri, he iti iho te tūpono ka peia atu koe ki mua tonu i te aroaro o ngā waka e ahu atu ana ki a koe.

Te huri ki, te huri rānei i tētahi rori e whai ana i te awarua wawaenga

Ko te awarua wawaenga ko tētahi wāhanga i waenganui o te rori, e tohungia ana ki ngā rārangi hauroki mā i waenga i ētahi rārangi whakarara. He wāhi haumaruru tērā hei wāhi tatari mō ngā waka e huri whakatematau ana i te rori, mō ērā rānei kātahi nei ka huri ki taua rori tonu.

E āhei noa ana tō haere i te awarua wawaenga ki te:

- » tatari ki te uru ki tētahi āputa i te rere o ngā waka whai muri i te huri whakatematau - ko te waka **A** i te hoahoa
- » whakapōturi i tō haere me te tatari i mua i te huringa - ko te waka **B** i te hoahoa.

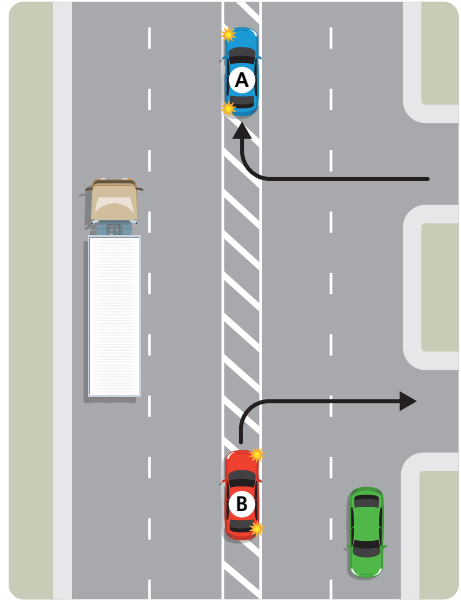

Kia aronuitia

Ka haere ana i tētahi awarua wawaenga, kia mataara ki te waehiko e tatari ana pea i te awarua wawaenga kia whakawhiti ai i te rori.

Te huri whakamuri

I te nuinga o te wā e āhei ana tō huri whakamuri, mēnā e wātea ana te rori i ngā ahunga e rua, ka mutu, e haumaruru ana te pēnā. Me whakaū koe he nui te wāhi wātea i te rori e taea ai tō huri whakamuri, tē hua māi ai ko tētahi mōreareatanga mō ngā waka e ahu atu ana ki a koe.

Kāore e āhei ana tō huri whakamuri i tētahi ara matua, mēnā rānei e kitea ana tētahi tohu e mea ana **'No U-turn'**.

Te huri mā te whakawhiti i tētahi rārangi tohipa-kore

Ina haumaruru te pēnā, e āhei ana tō whakawhiti i te rārangi kōwhai motukore e tohu ana kia kaua e tohipa, kia taea ai tō huri kia uru ki tētahi urunga, ki tētahi pekanga rori rānei.

Heoi anō, he rite tonu te kitea o ngā rārangi tohipa-kore i ngā wāhi e rehurehu ana te tirohanga, nō reira, me āta haere. Ka haumarua ake pea ina huri ki tētahi wāhi kē atu o te rori, e mārama ake ana te tirohanga. Tirohia te whārangi 59 mō ētahi mōhiohio anō e pā ana ki ngā rārangi tohipa-kore.

Te whakamahi tika i ngā ara

He mea peita ngā ara hei whakawehe i ngā waka. He mea nui kia tika tō whakamahi i ngā ara.

Ngā tikanga ara i ngā pūtahi

Me hou atu ki te ara e hāngai ana ki tō ahunga. Whāia te ahunga o ngā pere i te rori.

I te korenga o ētahi pere:

- » me huri whakatemauī i te ara whakatemauī
- » me huri whakatemataū i te ara whakatemataū
- » whakamahia tētahi o aua ara kia ahu tōtika atu ai.

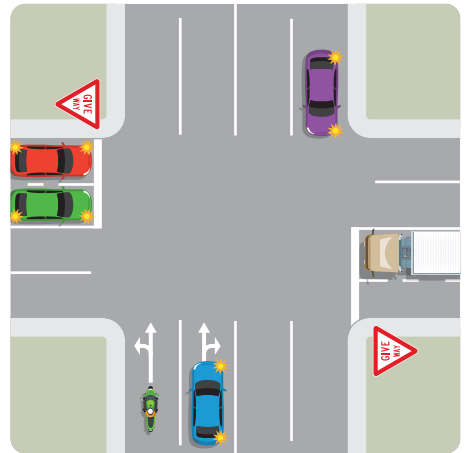

Me ū ki te ara-kotahi i te roanga o te pūtahi.

Te huri whakatemataū i tētahi pūtahi whai ara

Ka huri whakatemataū ana koe i tētahi rori e rua nui atu rānei ōna ara i ia ahunga, ki tētahi rori anō e rua nui atu rānei ōna ara i ia ahunga:

- » me hou atu ki te ara huri whakatemataū
- » me tūtohu mō te 3 hēkena, roa atu rānei, i mua i te huringa
- » me huri ki te ara tika o te rori.

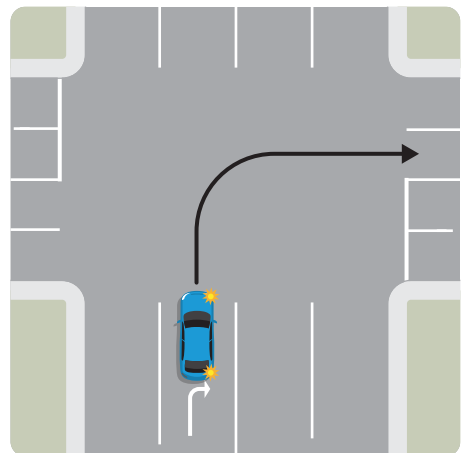

Te huri whakatematau ki tētahi tiriti ahutahi

Ka huri ana ki tētahi tiriti ahutahi:

- » mēnā kei tētahi tiriti ahurua koe, me huri atu i te ara i te taha o te rārangi waenga
- » me tūtohu mō te 3 hēkena, roa atu rānei, i mua i te huringa
- » me huri ki te ara o te tiriti ahutahi e pātata katoa ana ki a koe.

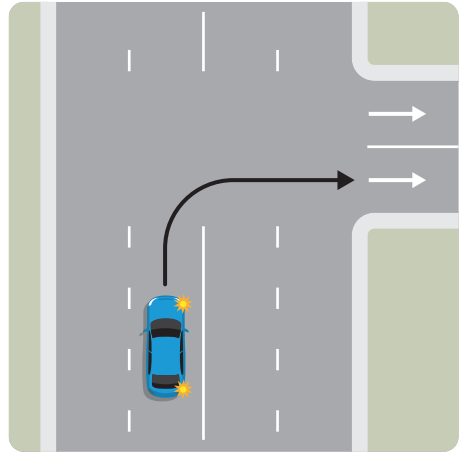

Te huri whakatematau i tētahi tiriti ahutahi, i tētahi rori ara-tini rānei

Ka huri whakatematau ana i tētahi tiriti ahutahi, me ū ki te ara-kotahi i te roanga o te huringa.

Nō reira:

- » mēnā koe e huri atu ana i te ara mauī o te tiriti ahutahi, me huri ki te ara mauī o te tiriti ahurua
- » mēnā koe e huri atu ana i te ara matau o te tiriti ahutahi, me huri ki te ara kei te taha mauī pū o te rārangi waenga o te tiriti ahurua.

Kei wareware ki te tūtohu mō te 3 hēkena, roa atu rānei, i mua i te huringa.

Ka huri atu ana i tētahi rori ara-tini, ko aua tikanga tonu rā.

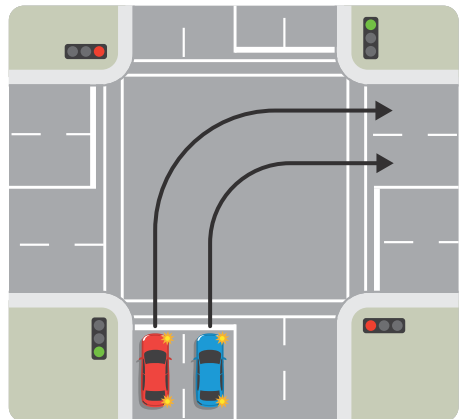
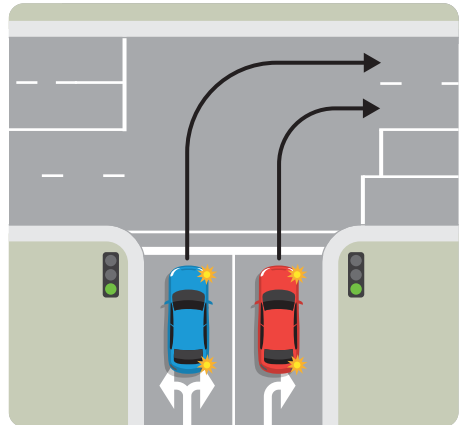



Kia aronuitia

Mēnā koe e huri ana i tētahi pūtahi, i reira rā ko tētahi ara pahikara, me tautuku ki ngā kaieke pahikara e ahu tōtika tonu atu ana.

Ngā waka e rua e huri ana ki te rori kotahi i tētahi pūtahi whai ara

Mēnā e rua ngā waka e huri ana ki te rori kotahi mā tētahi pūtahi, e rua, nui atu rānei ōna ara i ngā ahunga e rua:

- » me tohu ngā waka e rua i te hiahia kia huri mā te tūtohu mō te 3 hēkena, roa atu rānei
- » ka ū ngā waka e rua ki ō rāua anō ara kia tutuki rā anō te huringa:
 - › ko te waka **A** ka huri atu i te ara mauī, ka tau ai ki te ara mauī
 - › ko te waka **B** ka huri atu i te ara matau, ka tau ai ki te ara matau.

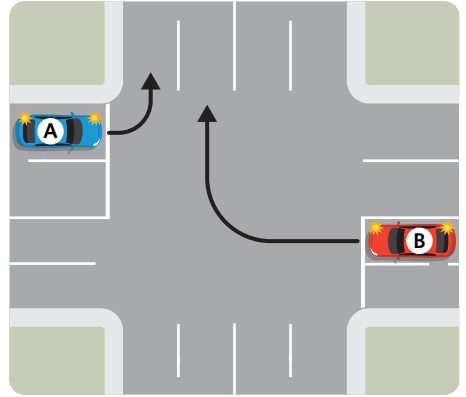

Te whakawhiti ara ki tētahi pūtahi

Me ngana ki te hou atu ki te ara e tika ana i mua i te taenga atu ki te pūtahi. Heoi anō, ki te mate koe ki te whakawhiti ki ara kē:

- » me whakaū i te haumarua i mua i te tīmata ki te pēnā
- » me tūtohu mō te 3 hēkena, roa atu rānei, i mua i te whakawhiti
- » i mua i te whakawhiti ki ara kē, me tiro whakamuri ki tua o tō pokohiwi kia mōhio ai karekau he waka kei ngā whaitua huna.

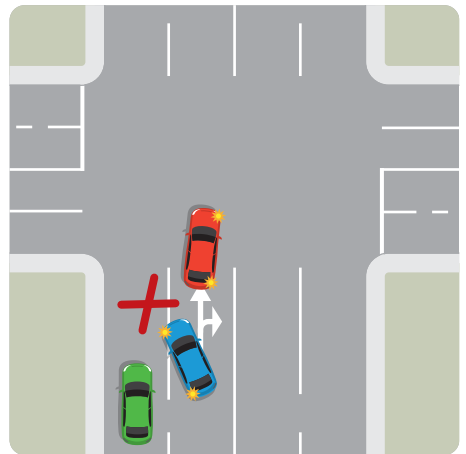

Kia kua rawa e matawhawhati te whakawhiti ki ara kē.

Te ara tohipa

Ka kitea ana he ara tohipa, me ū ki te ara whakatemāui, hāunga rā te wā e tohipa ana koe i tētahi atu waka.

Mēnā kua pōturi iho tō haere tēnā i te paetere, kua e whakahoro i tō haere ka tae ana ki tētahi ara tohipa mēnā he waka anō e whai ana i a koe - tukuna rātou kia tohipa, kia haumarua ai. Mō ētahi mōhiohio anō e pā ana ki te tohipa, tirohia te whārangi 57.

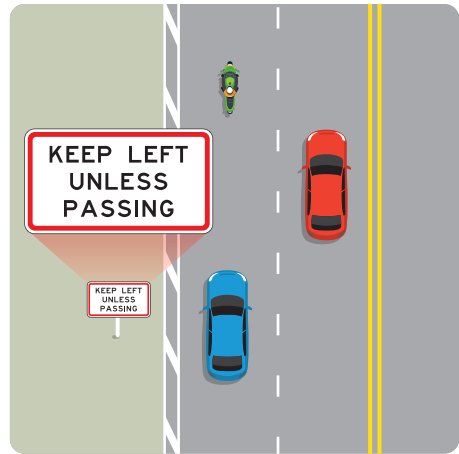

Ngā ara waka motuhake

Ko ngā ara waka motuhake e whai ana i te tohu, i te māka rānei hei whakaatu atu hei ara ērā mō ētahi momo waka anake, pēnei i te pahi, i te pahikara, i te tēkehi, mō ngā waka rānei e kawea ana i tētahi tokomaha pāhihi kua āta tohua - arā, he ara herenga motuhake. Mō ētahi tauira o ngā tohu mō ngā ara waka motuhake, tirohia te whārangi 30.

E āhei ana te hou atu a ngā momo waka kē atu ki te ara waka motuhake kia huri, kia tau rānei ki tētahi tūranga waka. Ina whakamahia pēneitia ai te ara, me poto te wā, ka mutu, me kua e nui atu i te 50 mita e pēnā ana. Me mātua tautuku ki ngā waka e wātea ana ki te whakamahi i te ara.

Ka wātea ētahi ara waka motuhake hei whakamahi mā ngā waka kua āta tohua mō ngā hāora e 24 i te rā. He wā motuhake ka tohua i ētahi, hei tauira, mai i te 4-6 karaka i te ahipō. Ki te pēnā, ka āhei pea tō whakatū i tō waka ki aua ara i waho atu o ēnei wā.

Kia aronuitia

Me roa ake e urupare ai ētahi tāngata ki te mōreareatanga, tēnā i tā tangata kē atu.

Mēnā koe e ngenge ana, mēnā rānei ka pōturi ake tō urupare tēnā i tāu i te nuinga o te wā, me whakaroa ake tō tawhiti whaiwhai i te waka i mua i a koe.

Te tawhiti whaiwhai

He mea nui kia haumaru te tawhiti i waenga i tō waka me tērā i mua i a koe, e taea ai tō whakatū noa i te waka i te wā poto ina mate ki te pērā. Mā reira anō e mārāma ake ai te kitea o te ara ki tua me ngā mōreareatanga me karo e koe.

E hia nei ngā hēkena ka hipa mai i tō kite atu i te mōreareatanga tae pū atu ki tō āhei ki te whakatū mārika i te waka. E pēnei ana i te mea me whai wā koe ki te aro me te urupare ki te mōreareatanga. Whakaarohia te nui o te wā ka pau i a koe e tau ai tō wae ki te whakatumu, tae atu anō hoki ki te wā ka pau e whakapōturi ai ngā whakatumu i te waka.

Ka tere ake ana te haere, me roa ake te wā hei whakatū i te waka. Nō reira, me whakawhānui ake te tawhiti whaiwhai ka whakaterere ake ana koe i tō haere.

Te ū ki tētahi tawhiti whaiwhai e haumaru ana

Ko tētahi rautaki pai e ū ai koe ki tētahi tawhiti whaiwhai e haumaru ana, ko te whai i te tikanga 2-hēkena, i te tikanga 4-hēkena rānei.

Te tikanga 2-hēkena

I te nuinga o te wā, ko te tikanga 2-hēkena tētahi ara māmā e tika ai te nui o te tawhiti whaiwhai i waenga i tō waka me tērā kei mua i a koe, ahakoa te tere o te haere.

E mōhio ai mēnā rānei e 2 hēkena te roa i waenga i tō waka me tērā i mua:

- » mātakina te waka kei mua i a koe ka tohipa ana i tētahi tūtohu whenua, pēnei i te tohu, i te rākau, i te pouhiko rānei i te taha o te rori
- » ka tohipa ana te waka rā i te tūtohu whenua, me tīmata tō kaute i te 2 hēkena
- » ki te tohipa wawe koe i te tūtohu whenua i mua i te whakapaunga o taua 2 hēkena, kua pātata rawa tō haere – me whakapōturi tō haere, ka kōwhiri ai i tētahi tūtohu whenua anō, ka toai ai te kaute hei whakaū kua whakawhānuitia te tawhiti whaiwhai.

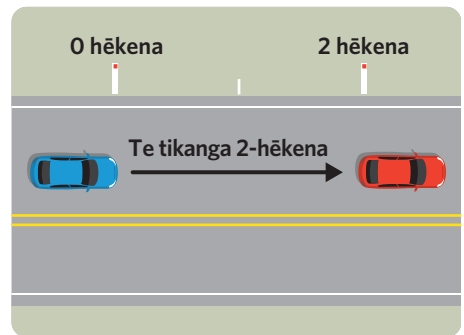

Te tikanga 4-hēkena

Ka kino ana te huarere, e mākū, e mania ana rānei te rori, e tō ana rānei koe i tētahi tauaru, me whakawhānui tō tawhiti whaiwhai kia 4 hēkena ai te roa, inā hoki, ka roa ake te wā hei whakatū i tō waka ina mate koe ki te pērā.

Mēnā e pātata ana te whai a te waka i muri i a koe, me:

- » whakaroa tō tawhiti whaiwhai i te waka i mua i a koe kia 4 hēkena ai te roa. Mā konei e wātea ake ai koe ki te āta whakapōturi i tō haere, me te whakaheke i te tūraru ka tukia a muri ina tumu ohotata
- » ka haumarua ana, ka āhei tō neke ki te taha o te rori, ka tuku ai i te waka kia tohipa.

E mōhio ai mēnā rānei e 4 hēkena te roa o te āputa i waenga i tō waka me tērā i mua, whāia ngā tohutohu mō te tikanga 2-hēkena, engari me kaute kē kia 4 hēkena ai te roa.



Kia aronuitia

Mēnā koe e whai ana i tētahi atu waka, ā, kāore i te whai kia tohipa, me mātua tuku koe kia rawaka te āputa i mua i tō waka e taea ai e ngā waka i muri i a koe te tohipa.

Te tohipa

He tini ngā tukinga kino i ō tātou rori, i hua i te mōrearea o te tohipa.

E haumarua ai te tohipa i tētahi atu waka, me tūpato rawa. Me mārama te kītea o te ara ki tua, e mōhio ai ka haumarua te tohipa. Me āta aro hoki ki te waka e tohipa nei koe, mō te tūpono ka panonihia tana ahunga.

Te tohipa mā te taha matau

Ka mōrearea pea te tohipa mā te taha matau, inarā ka mate koe ki te:

- » panoni i tō ahunga
- » whakawhiti ki tētahi ara, ki tētahi wāhanga rānei o te rori e whakamahia ana e ngā waka e ahu ana ki a koe.

I mua i te tohipa, whakaarohia 'me tohipa rawa au?' Kaua e tohipa, he hōhā noa iho nōu ki te waka kei mua i a koe - he rite tonu te hua mai o ngā tukinga i aua tūmomo āhuatanga.

Mēnā ka whakatau koe ki te tohipa, whāia ngā tikanga i raro iho nei.

I mua i te tohipa:

- » me whakaū ka mārama tonu te kītea o te 100 mita, roa atu rānei, o te wahi wātea i te rori, i te roanga o te wā e tohipa ana - ki te kore, kaua e tohipa
- » me tiro ki tua rā anō kia mōhio ai karekau he waka e ahu ana ki a koe
- » me tiro whakamuri kia mōhio ai karekau he waka e tohipa ana i a koe
- » me tūtohu whakatematau mō te 3 hēkena, roa atu rānei, me tiro hoki ngā whaitua huna i mua i te tohipa.

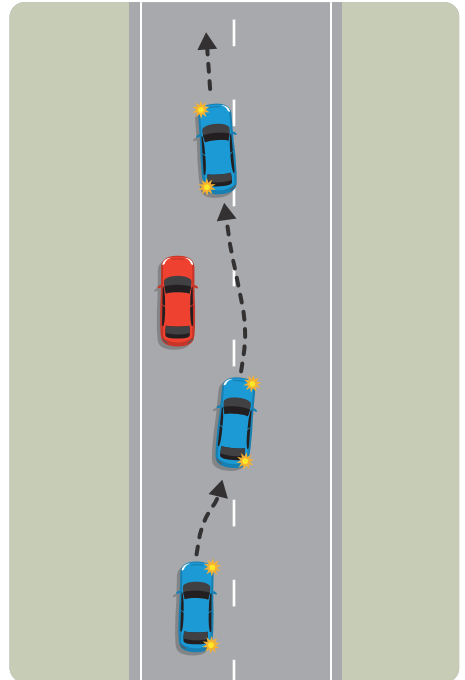

I mua i te hoki anō ki te ara i mua i te waka i tohipa rā koe, me:

- » whakaū e kitea ana te waka i tō whakaata aro whakamuri
- » tūtohu whakatemauī mō te 3 hēkena, roa atu rānei.

Kia aronuitia

Kia tūpato, me nui ake hoki te wāhi wātea, ka tohipa ana i te kaieke pahikara, i te hōiho, i te waehīkoi rānei, inā hoki, nā te rorohū o tō waka ka tītahataha haere pea ērā atu.

Te tohipa mā te taha mauī

E āhei noa ana te tohipa mā te taha mauī mēnā:

- » e rua, nui atu rānei ngā ara i tō taha o te rārangi waenga, ā, ka haumaruru tonu tō tohipa mā te ara whakatemauī
- » he mea tohutohu koe nā te pirihihana
- » ko te waka e tohipa ana koe:
 - › kua tū kē,
 - › e tūtohu ana rānei kua huri whakatematau,
 - › e huri whakatematau ana rānei.

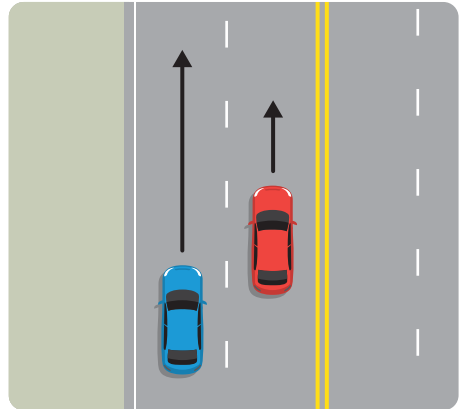

I tua atu i tērā, ka tohipa ana, me tohipa mā te taha matau.

Kia aronuitia

Me ū tonu ki tētahi tawhiti whaiwhai e haumaruru ana i muri i te waka ākuanei ka tohipatia. Whāia te tikanga 2-hēkena.

Ki te tohipa tētahi atu waka i a koe:

- » me neke ki te taha mauī rawa
- » kua rawa e whakaterere i tō haere kia kore ai tērā atu waka e tohipa.

Te rārangi tohipa-kore

I ētahi wāhanga o te rori, ka kitea he rārangi kōwhai motukore i tō taha o te rārangi waenga. Koia tēnei ko te rārangi tohipa-kore.

I te nuinga o te wā, kitea ai ngā rārangi tohipa-kore, he mōrearea nō te whakawhiti i te rārangi waenga kia tohipa ai, inā hoki, nā ngā āhuatanga pēnei i ngā puke me ngā kōpiko, e kore nei e kitea mēnā rānei he waka e ahu ana ki a koe.

He wā ōna ka kitea he rārangi tohipa-kore, inā hoki:

- » he ara tohipa kē kei tō taha o te rori, ā, me mātua whakamahi tērā kia tohipa ai.
- » he rori ara-tini kē, nō reira, kāore he take o te whakawhiti i te rārangi tohipa-kore e tohipa ai.

Me kua rawa e tohipa i tētahi waka, i tētahi waka rānei e tōia ana e te kararehe, mēnā mā te pēnā ka mate koe ki te whakawhiti i tētahi rārangi tohipa-kore i tō taha o te rārangi waenga.

Ina kitea he rārangi kōwhai nakunaku i tō taha o te rārangi waenga, he tohu tērā kua tīmata tonu ētahi rārangi tohipa-kore.

Ahakoia e pai ana tō whakawhiti mai i te rārangi kōwhai nakunaku e tutuki ai te tohipa, me kua e whakawhiti kia tīmata noa te tohipa.

E kitea ana i te pikitia i raro iho nei:

- » e āhei ana tō whakawhiti mai i te rārangi kōwhai nakunaku i waenga i te **A** me te **B** e tutuki ai te tohipa
- » me kua rawa e whakawhiti i te rārangi kōwhai motukore i waenga i te **C** me te **D**.

E āhei ana tō tohipa i tētahi rārangi tohipa-kore mēnā:

- » ka ū tonu koe ki tō taha o te rārangi kōwhai motukore, ā,
- » ka 100 mita te nui o te wāhi wātea e kitea ana i te rori i te roanga o te wā e tohipa ana
- » e rawaka ana anō hoki te whānui o te ara e ō ai ngā waka e rua.

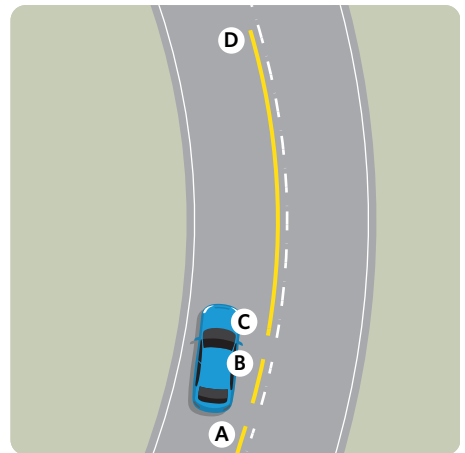

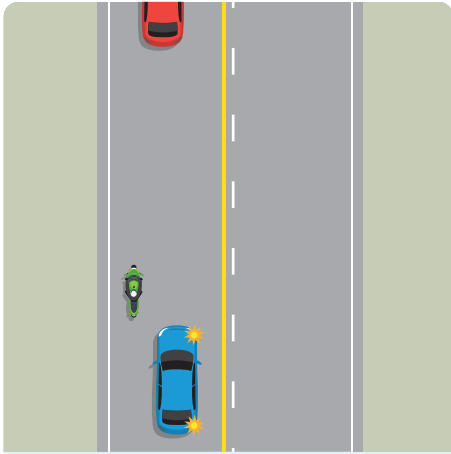

Ko te tohipa me te kore i whakawhiti i te rārangī tohipa-kore

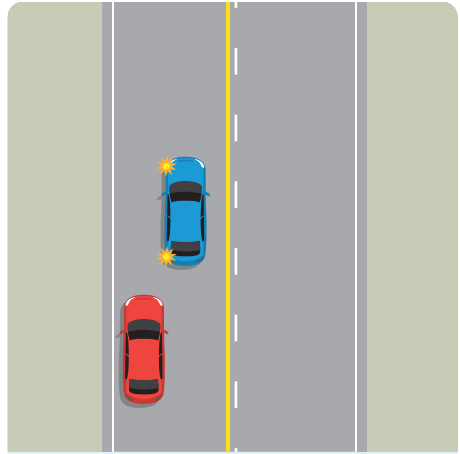

Ko te tohipa me te kore i whakawhiti i te rārangī tohipa-kore

Te tohipa i tētahi rori ara-toru

Mēnā karekau he rārangī kōwhai motukore i tō taha o te rārangī waenga, e āhei ana tō whakamahi i te ara waenga hei tohipa mēnā:

- » karekau he waka kē atu i taua ara rā, ā,
- » ka 100 mita te nui o te wāhi wātea e kitea ana i te rori i te roanga o te wā e tohipa ana.

Kaua e whakamahi i te ara waenga hei tohipa mēnā he waka anō i te ara waenga e ahu ana ki a koe.

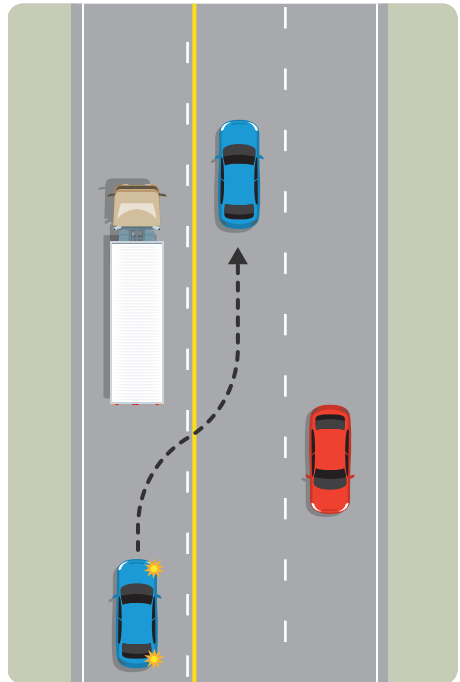

Te tohipa i te pahikara

Ka tohipa ana, me tuku koe kia 1.5 mita, nui atu rānei, te nui o te āputa i waenga i tō waka me tētahi pahikara. Mēnā kāore e haumarua ana te tohipa, me whakapōturi tō haere, ka noho tonu ai ki muri i te pahikara, kia haumarua rā anō.

He wā ōna ka pīrangi pea te kaieke pahikara ki te neke ki te puku o te ara, kia haumarua tonu ai. Ka kīia tēnei ko te whakakapi i te ara. E āhei ana tō whakamahi i te awarua wawaenga hei tohipa, mēnā e haumarua ana tō pēnā.

Ko ngā horopaki e āhei ana tā te kaieke pahikara whakakapi i te ara:

- » i ngā pūtahi porotaka
- » ka huri whakatemataua ana i ngā pūtahi
- » ka huri whakatemalaū ana i ngā pūtahi
- » mēnā he whāiti rawa te rori e kore nei e haumarua tā ngā waka tohipa
- » mēnā ka tūpono tuwhera noa ngā kūaha o tētahi waka kua tū kē i mua i a rātou.

Kitea ai pea he tohu pere-rua i ēnei horopaki.

Ko tā ngā tohu pere-rua i te rori, he whakaatu i ngā wāhi i te puku o te ara e tinga ana ka ū ai te kaieke pahikara, kia haumarua ai. Me whakapōturi tō haere, ka whai ai i te pahikara kia whānui haere anō te rori, kia haumarua hoki tō tohipa, me whakamahi rānei i tētahi ara kē kia tohipa ai.

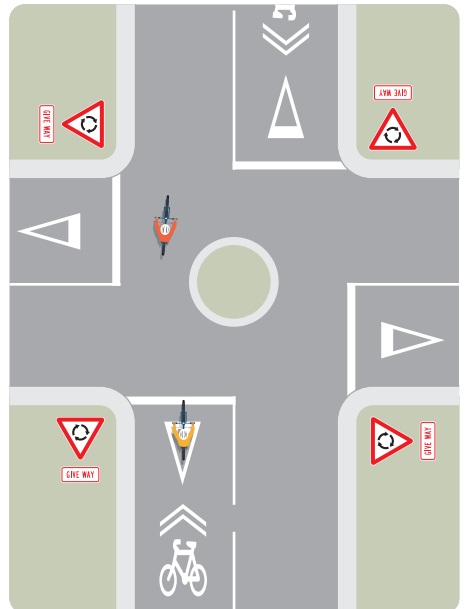
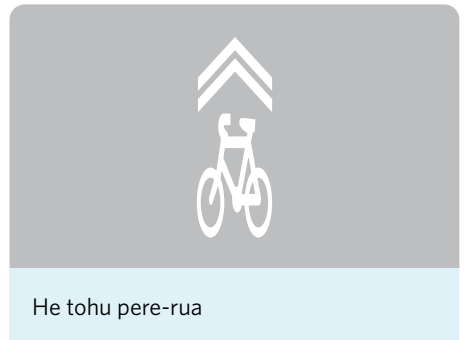
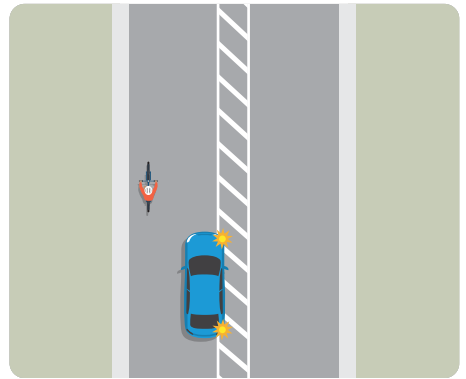

Ngā wā me kaua rā e tohipa

Kia mahara ake, he mahi taihara te whakawhiti i tētahi rārangi tohipa-kore i tō taha o te rārangi waenga kia tohipa ai. Heoi, ehara i te mea koinei anake te wā me kaua koe e tohipa. Arā atu anō ngā wā ka kīia he mōrearea, he mahi taihara hoki te tohipa.

Kaua e tohipa i tētahi waka kua tū kē, e whakapōturi ana rānei te haere mō te waehiko i tētahi whakawhitinga waehiko.

Kaua e tohipa i a koe e whakatata haere ana ki tētahi koki huna, ki tētahi kōpiko rānei. Ko te koki huna, ko te kōpiko rānei, ko ngā wāhi kāore e kitea ana e koe he aha kei tua o te koki.

Kaua e tohipa mēnā kāore e eke ki te 100 mita, neke atu rānei, te roa o te wāhi wātea e kitea ana i te rori i te roanga o te wā e tohipa ana.

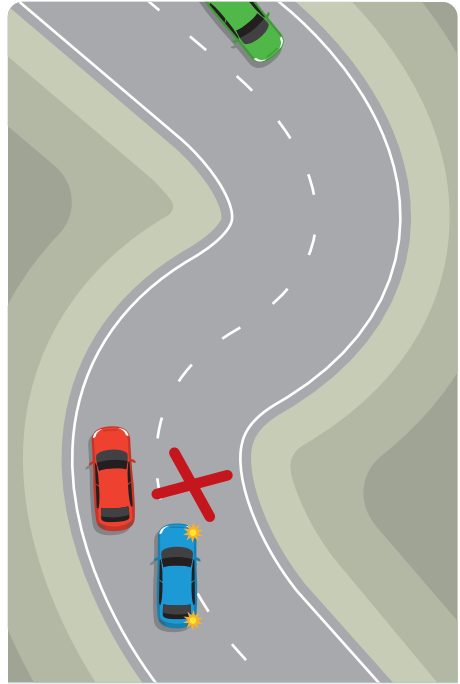

Ko te tohipa taihara i tētahi kōpiko



Ko te tohipa taihara e pātata ana ki tētahi whakawhitinga waehiko

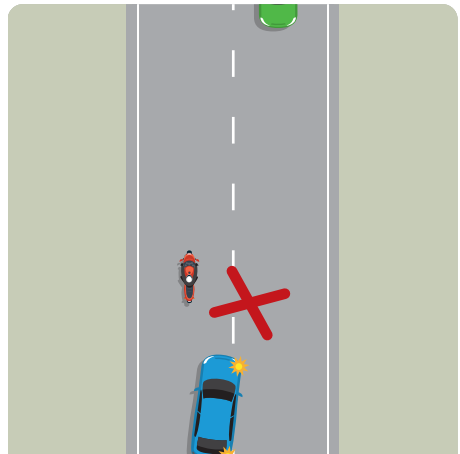

Ko te tohipa taihara me te korenga o te wāhi wātea i te rori e eke ki te 100 mita

Ka whakatata atu ana, ka whakawhiti ana rānei i tētahi pūtahi, kua e tohipa mā te taha matau o te waka mēnā mā te pērā ka whakawhiti koe i te rārangi waenga. Me kua rawa e aukati i:

- » ngā waka e ahu pēnā atu ana ki a koe
- » ngā waka e puta mai ana i ngā pekanga.

Kaua e tohipa i:

- » tētahi waka e neke ana mēnā he poto iho i te 60 mita tō tawhiti i tētahi whakawhitinga ara tereina
- » tētahi waka kua tū kia hipa rā anō tētahi tereina.

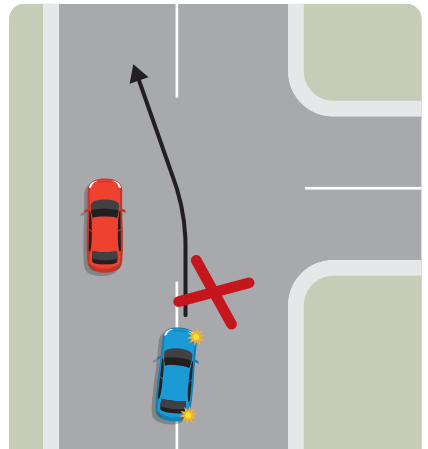

Te tohipa taihara i tētahi pūtahi

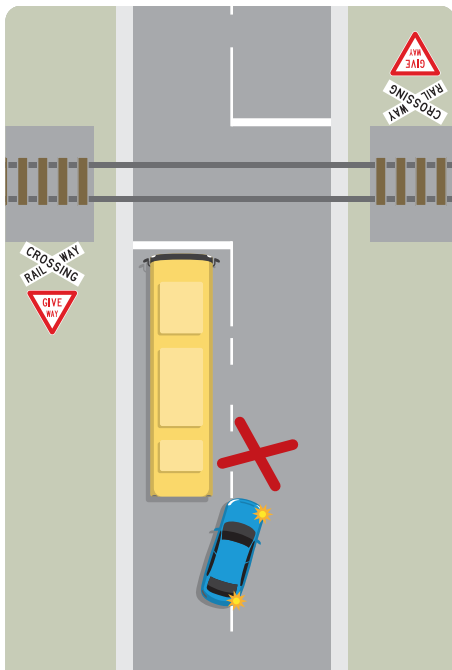

Te tohipa taihara i kō tata atu ki tētahi whakawhitinga ara tereina

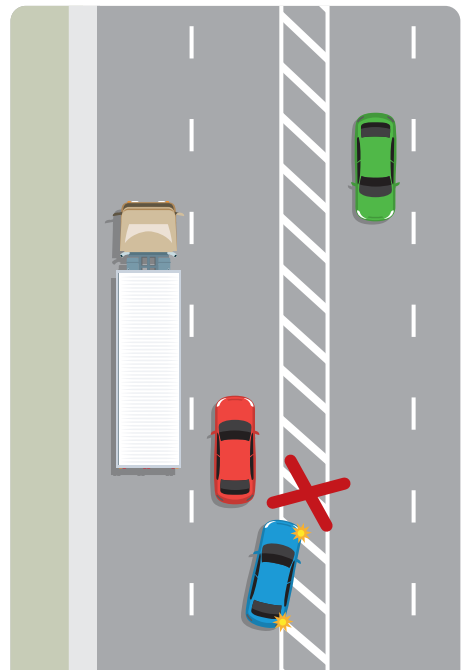

Te tohipa taihara mā te awarua wawaenga

Kaua e tohipa mēnā ka mate koe ki te haere mā te awarua wawaenga. Tirohia te whārangi 50 mō ētahi mōhiohio anō e pā ana ki te awarua wawaenga.

Te tohipa i tētahi pūtahi

He wā ōna e āhei ana tō tohipa i tētahi atu waka i te pūtahi. Engari, me tino tūpato ka pēnei ana.

Te tohipa mā te taha mauī i tētahi pūtahi me tētahi ara-kotahi i tō taha o te rori

I tēnei horopaki, e āhei ana tō tohipa mā te taha mauī mēnā e rawaka ana te wāhi wātea i tō ara e tutuki ai te tohipa, ka mutu, ko te waka ka tohipatia rā:

- » kua tū kē,
- » e tūtohu ana rānei ko te huri whakatematau,
- » e huri whakatematau ana rānei.

Kaua e tohipa mēnā kua tūtohu te waka ka huri whakatemauī.

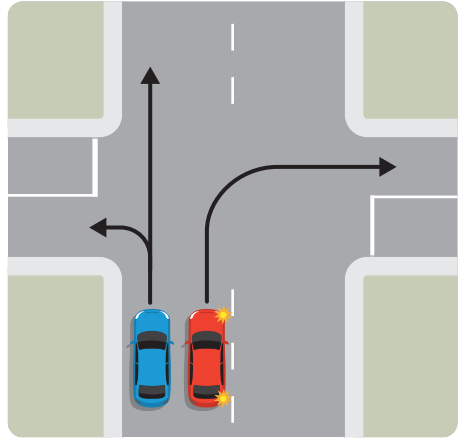

Te tohipa mā te taha mauī i tētahi pūtahi, e rua, nui atu rānei ngā ara i tō taha o te rori

I tēnei horopaki, e āhei ana tō tohipa mā te taha mauī mēnā kei tētahi ara rerekē te waka e tohipatia ana, ā, ka haumaru tō pēnā.

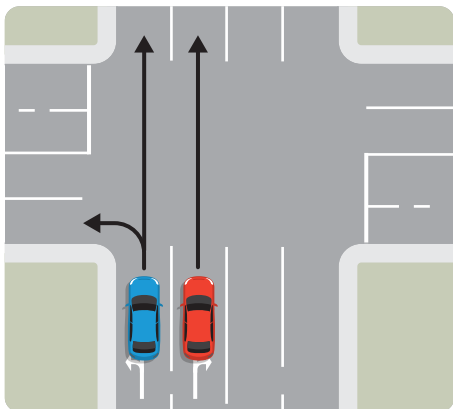

Te tohipa mā te taha matau i tētahi pūtahi, e rua, nui atu rānei ngā ara i tō taha o te rori

I tēnei horopaki, e āhei ana tō tohipa mā te taha matau mēnā e huri whakatematau ana koe, mēnā rānei e ahu tōtika ana.

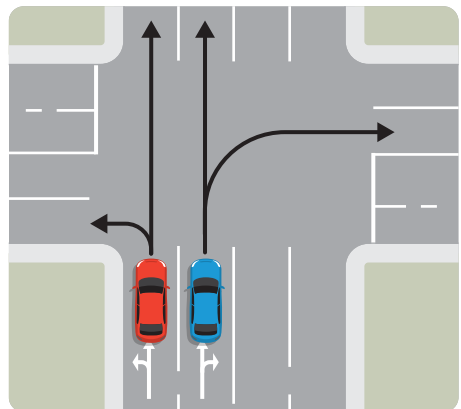

Te kōmiti

He wā ōna, ka kōmiti ngā ara e rua i tētahi rori, kia kotahi ai.

Ka kōmiti ngā ara i te whakapaunga o ngā rārangi nakunaku i te ara. He mea nui kia rawaka te wāhi ki ngā waka nō ngā ara e rua, e haumaruru ai te kōmiti.

Te kōmiti me he kōtuitui

Ko te painga atu kia kōmiti anō he kōtuitui, arā, ka koke tētahi waka nō te ara mauī, ka whai atu ai ko tētahi nō te ara matau, ka haere tonu te pērā.

Ka kōmiti ana, me tuku tētahi waka nō tērā atu ara kia koke, ka whai atu ai.

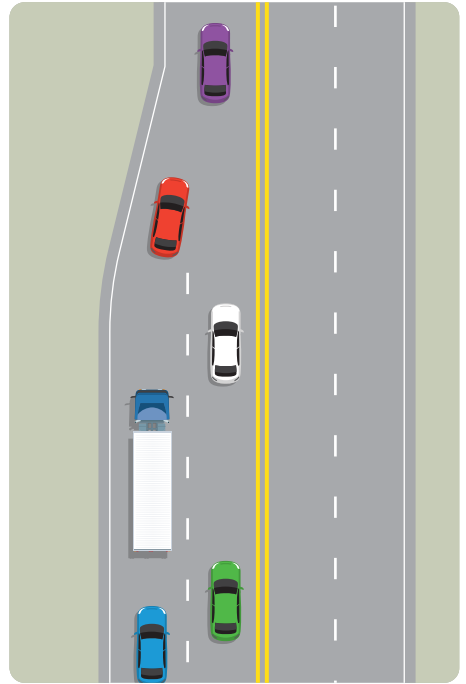

Te wehe i tētahi ara kōmiti ka huri whakatematau ana i tētahi pūtahi

He ara kōmiti tō ētahi rori hei āwhina i ngā waka kua huri ki taua rori rā kia kōmiti ai ki te rere o ngā waka i te rori.

Mēnā kei tētahi ara kōmiti koe i tētahi pūtahi:

- » me tohu e pīrangiri ana koe ki te kōmiti mā te tūtohu mō te 3 hēkena, roa atu rānei
- » me uru ki tētahi āputa haumaruru i waenga i ngā waka i te rori
- » me whakahāngai te tere o tō haere, me tō tawhiti whaiwhai.

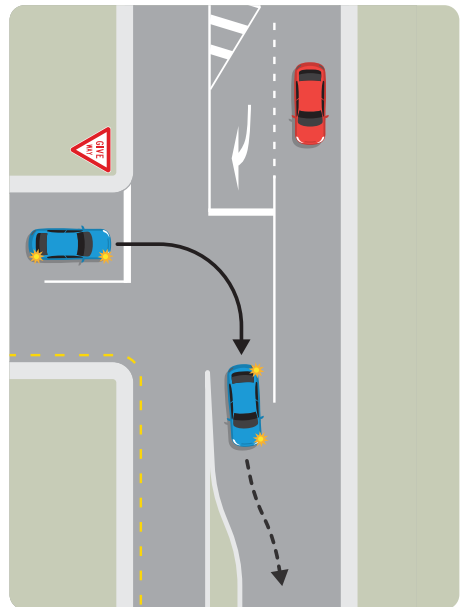

Te haere mā ngā urunga me ngā putanga ka uru ana ki te ara matua, ka puta ana anō hoki

E āhua ōrite ana ngā urunga ki ngā ara kōmiti. Ka haere ana mā tētahi urunga e uru ai ki tētahi ara matua:

- » me panoni te tere o tō haere kia hāngai ai ki tō ngā waka i te ara matua
- » me whakamahi te roanga o te urunga kia panoni ai i te tere o tō haere kei panoni noatia ka uru atu ana ki te ara matua
- » me tūtohu whakatemataui mō te 3 hēkena, roa atu rānei
- » me hou atu ki tētahi āputa haumaruru i waenga i ngā waka i te rori
- » kua e uru ki te ara matua mā tētahi koki tāhapa
- » me whakahāngai te tere o tō haere, me te tawhiti whaiwhai.

Ka haere ana mā tētahi putanga e puta ai i tētahi ara matua:

- » kia takatū ki ngā tohu putanga
- » me tūtohu whakatemauī mō te 3 hēkena, roa atu rānei
- » kia wawe te neke ki te ara mauī
- » me hāngai tonu te tere o tō haere ki tō te rere o ngā waka kia tau rā anō ki te putanga
- » kua e puta i te ara matua mā tētahi koki tāhapa
- » me whakahāngai te tere o tō haere.

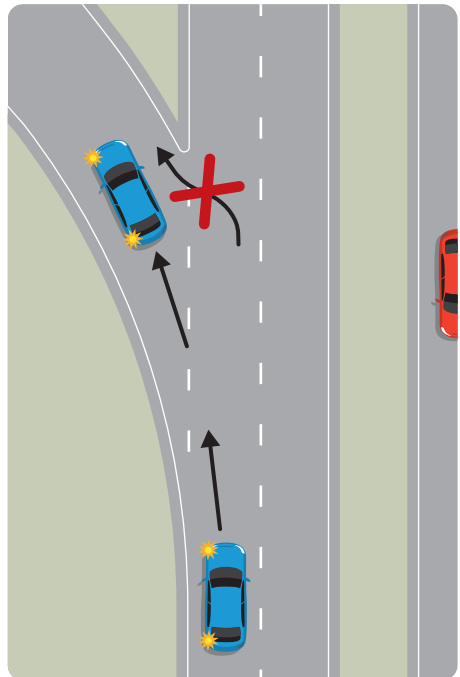
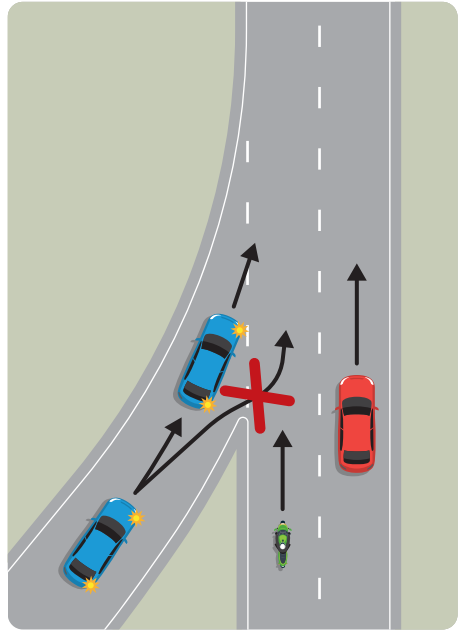

Te hautū i te ara matua

He mea whakarite ngā ara matua kia pai ai te rere o ngā waka, kia iti rawa ai ngā pōrarururutanga. I tētahi ara matua, i tōna tikanga kāore koe e tūpono atu ki ngā mea ka whakararu i te rere o ngā waka, pērā i te pūtahi, i te waka e huri ana, i te waka kua whakatūria, i te waehikoī anō hoki.

Ahakoā ka iti iho ngā mōreareatanga i ngā ara matua, me tūpato tonu i a koe e hautū ana, he tere nō te haere o ngā waka i te nuinga o te wā.

Ngā tohu i ngā ara matua

He kākāriki te nuinga o ngā tohu i ngā ara matua, me te mā ki ngā tapa.

Kia āta aro ki ngā tohu e whakaatu ana i te tīmatanga, i te mutunga hoki o te ara matua, tae atu anō ki ngā tohu e whakaatu ana i ētahi putanga.



MOTORWAY
ENDS



Tawa
USE LEFT
LANE



EXIT
8
←

Te hautū kia haumaru i ngā ara matua

Ka hautū ana i tētahi ara matua:

- » kia ū ki te taha mauī, hāunga rā te tohipa
- » kia takatū ki ngā tohu putanga
- » kia wawe te neke ki te ara putanga e tika ana
- » me tūtohu mō te 3 hēkena, roa atu rānei, i mua i te whakawhiti ki ara kē
- » kua rawa e whakatū i tō waka, hāunga i te take ohotata
- » kua rawa e huri whakamuri
- » kua rawa e whakatū i tō waka kia whakataka i te pāhihi, kia piki rānei ētahi ki tō waka
- » ki te mahue i a koe tō putanga, kua e whakatū i tō waka ka haere whakamuri ai - me koke tonu ki te putanga whai muri ake.

Te haere whakamuri

Me whakaū i te wātea o te ara, ka haere whakamuri ana. He whaitua huna tō ngā waka katoa, nō reira, me mātau ki ngā whaitua huna o tō waka, ka āta aro ai ki ngā whaitua nei, ka haere whakamuri ana. Mēnā e paku māharahara ana koe kāore pea te ara i muri i a koe e wātea ana, e puta i tō waka ka whakaū ai.

Ia tau, he nohinohi ka mate, ka whara anō hoki i te waka e haere whakamuri ana. **Me** whakaū rawa karekau he nohinohi i kō i tō waka i mua i te koke. He matawhawhati te nohinohi, ka mutu, he tere te haere. Mēnā ko koe me tō kotahi e manaaki nohinohi ana, ka mutu, ka mate ki te neke i te waka, ko te wāhi haumarū katoa mō ngā tamariki, ko roto o te waka, i tō taha.

Ngā aratohu mō te haere whakamuri

Whāia ngā aratohu nei, ka haere whakamuri āna:

- » Tōmua i te koke, me whakaū e haumarū ana tō haere whakamuri. Ko te ara pai katoa e tutuki ai, ko te hīkoi āwhio i te waka kia mōhio ai karekau he tamariki, he taero atu anō rānei kei tō ara.
- » Kei whakawhirinaki noa ki ngā whakaata, ki ngā kāmera, ki ngā paerongo noa nei rānei. Me huri, ka tiro ai ki tua o tō pokohiwi.
- » Me ngana kia tōtika te haere whakamuri.

Te tautuku

Ākona mō āhea koe tautuku ai ki waka kē atu i a koe e hautū ana, me whai māramatanga anō hoki ki ngā mahi e tika ana i ētahi horopaki rerekē, i ētahi pūtahi rerekē anō hoki. He mea nui tō mōhio ki ngā tikanga tautuku.

He aha rānei te pūtahi?

Ko te pūtahi, ko tētahi wāhi:

- » e tūtaki ai, e whakawhiti ai rānei ētahi tiriti e rua, nui atu rānei
- » e tūhono ai tētahi urunga, tētahi putanga tūmatanui rānei ki tētahi tiriti, ki tētahi rori rānei.

E kapi ana i ngā pūtahi ko ngā urunga me ngā putanga nō ngā hokomaha, nō ngā whare penehīni, me ngā wāhi tūmatanui kē atu hei whakatū waka, pēnei i te taunga rererangi me te hōhipera. He tini ngā momo pūtahi rerekē, e ai anō ki te nui o ngā rori e tūtaki ana i te pūtahi.

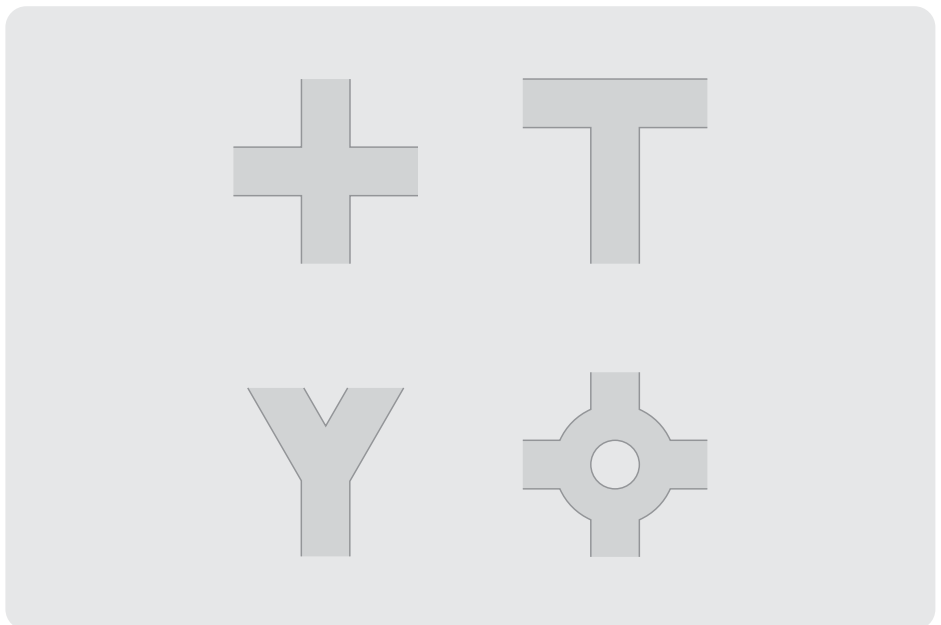

Te ahu atu ki te pūtahi

Mēnā he waka kē atu e ahu atu ana ki tētahi pūtahi, e whakawhiti ana rānei, kaua e whakaterere ake i tō haere, i a koe e whakatata atu ana. Whakamahia te pūnaha whakahaere waka hei āwhina i a koe, kia haumaruru ai tō aro ki ngā mōreareatanga.

- » **Te ahunga** - kimihia tētahi ara e haumaruru ana, e hāngai ana ki te ture anō hoki.
- » **Ngā whakaata** - me tiro whakamuri, me tiro hoki ko ngā whaitua huna.
- » **Me tūtōhu** - mō te 3 hēkena, roa atu rānei, mēnā ko te huri.
- » **Te whakatumu** - me whakapōturi te haere, e taea ai tō tautuku mēnā e tika ana te pēnā.
- » **Ngā nihowhiti** - me whiti mēnā e tika ana kia pēnā.

Ka haumaruru ana:

- » **Me whakahoro** - kia hāngai ai ki te horo o ngā waka.

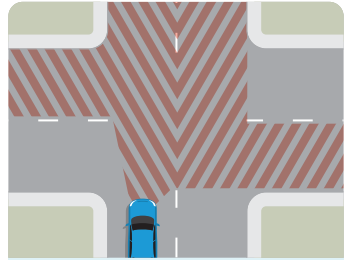

Ko tā te wāhi kauruku whero i te hoahoa i runga nei he whakaatu i ngā wāhi me āta tiroiro i mua i te uru ki tētahi pūtahi.

He aha rānei ngā tikanga tautuku?

- » Me tū, me tautuku rānei ngā kaihautū ki ngā tohu tū, ki ngā tohu tautuku, me ngā rama pūtahi.
- » Mēnā e huri ana koe, me tautuku ki ngā waka kāore i te pēnā. **Kia mōhio mai:** mēnā e peka atu ana koe i te rārangi waenga, ka kīia e huri ana koe, me te aha, me tautuku ki ngā waka e whai tonu ana i te rārangi waenga.
- » Mēnā e huri whakatemataua ana koe, me tautuku ki ngā waka katoa e ahu pēnā atu ana ki a koe, tae atu ki ērā e huri whakatemaui ana. **Kia mōhio mai:** ka mau tonu tēnei tikanga mēnā karekau he tohu, he rama pūtahi rānei i mua i ngā waka e rua, mēnā rānei e aro atu ana ki ngā tohu, ki ngā rama pūtahi ōrite rānei.
- » I ngā pūtahi-T, i ngā kuhunga rānei, me tautuku ngā waka kei tētahi whakapaunga rori, whakapaunga kuhunga rānei (ko raro o te T) ki ngā waka katoa kei tētahi ara moroki (ko runga o te T).
- » I horopaki kē atu, me tautuku ki ngā waka katoa e ahu pēnā atu ana i tō taha matau, hei tauira, i tētahi pūtahi porotaka, i tētahi ara rīpeka rānei e whakahaerehia ana e te rama pūtahi, ina raru aua rama pūtahi, ā, he rama kōwhai e rarapara ana i ngā ahunga katoa.

Ngā waka e rua e ahu atu ana ki a rāua anō, e huri whakatematau ana

Ka ahu ana ngā waka e rua ki a rāua anō, ka mutu, e huri whakatematau ana rāua tahi, i tōna tikanga, kāore tētahi e mate ki te tautuku.

E pēnei ana i te mea kāore rāua e whakawhiti i te ahunga o tērā atu, nō reira, ka haumaruru tonu te huri a aua waka e rua. Heoi anō, me tūpato mēnā he taraka nui, he pahi rānei tērā atu waka, inā hoki, me nui ake pea te wāhi e hiahia ana e tutuki ai te huringa.

Kei wareware ki te tiro mēnā rānei he waka e ahu pēnā atu ana ki a koe, e ahu tōtika tonu atu ana i te pūtahi. Ka āraia pea tō tirohanga e te waka e huri ana.

I te tini o ngā pūtahi, he mea whakahaere ngā waka nā ngā tohu tū, ngā tohu tautuku, ngā rama pūtahi rānei. Tirohia ngā whārangi e whai mai ana e mārāma ai mō āhea whāia ai ngā tikanga tautuku i ēnei pūtahi.

Mēnā e whakahaere ana tētahi pirihihana i ngā waka, me whai rawa koe i ana tohutohu inā hoki, ka noho mātāmua i ngā tikanga tautuku.

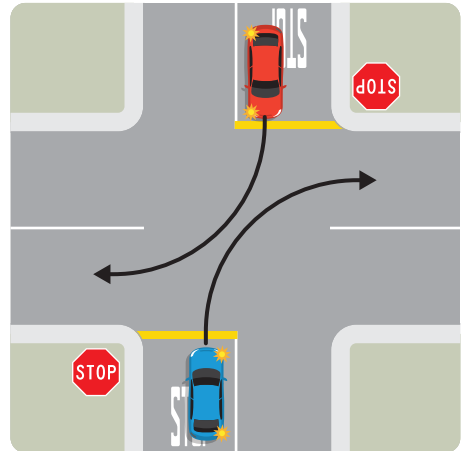
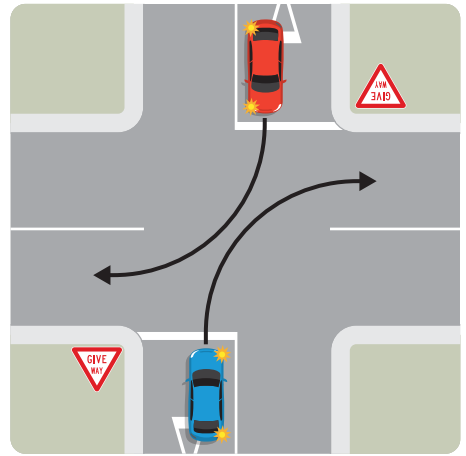

Te tohu tū

I tētahi pūtahi e whakahaerehia ana e te tohu tū:

- » me whakatū mārika tō waka - ehara i te mea me whakapōturi noa
- » me tū ki tētahi wāhi e kitea ai ngā waka i ngā ahunga katoa
- » me tū tonu kia oti rā anō i a koe te tautuku ki waka kē atu, tae atu ana ki ngā pahikara me ngā motupaika

» mēnā he tohu tū kei mua i tō waka me tō tētahi atu, whāia ko ngā tikanga tautuku - tirohia ngā whārangi 73-76

» me kua rawa e koke kia haumaruru rā anō.

Ka kitea te kupu STOP me tētahi rārangi kōwhai kotahi kua peitahia ki te rori.

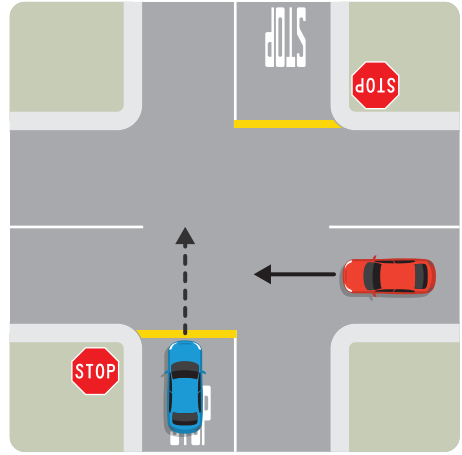

Te tohu tautuku

I tētahi pūtahi e whakahaerehia ana e te tohu tautuku:

- » me whakapōturi tō haere, ka takatū ai ki te tū
- » me tautuku ki waka kē atu, hāunga i ērā e aro ana ki tētahi tohu tū
- » mēnā he tohu tautuku kei mua i tō waka me tētahi atu, whāia ko ngā tikanga tautuku
- » me kua e koke kia haumaruru rā anō.

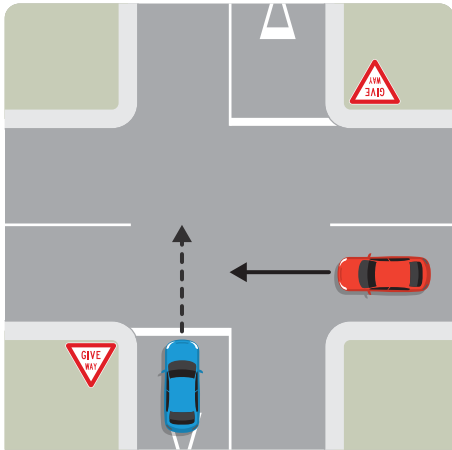

Ka kitea he tapatoru tautuku me tētahi rārangi mā kua peitahia ki te rori.

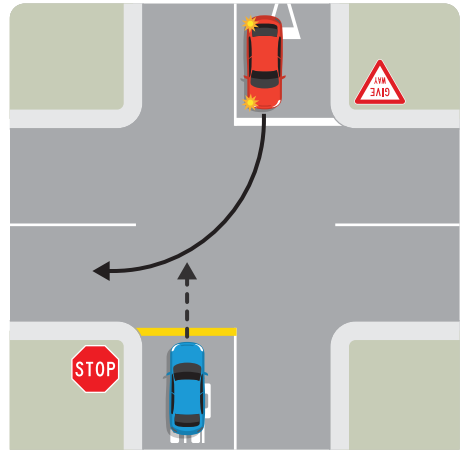

Ko tētahi waka e aro atu ana ki tētahi tohu tū, ka tautuku ki tētahi waka e aro ana ki tētahi tohu tautuku.

Ngā tikanga tautuku

Arā anō ngā tikanga tautuku ka hāngai ki ngā pūtahi.

Mēnā e huri ana koe, me tautuku ki ngā waka katoa kāore i te huri.

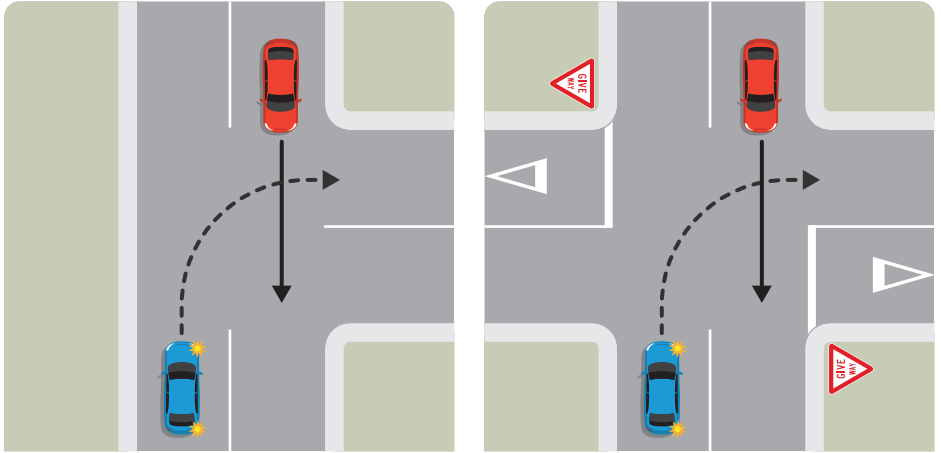

E kapi ana i tēnei ko te tautuku ki ngā kaieke pahikara e haere ana i ngā ara pahikara me ngā ara pahi, me ngā waka e whakamahi ana i ngā ara pahi.

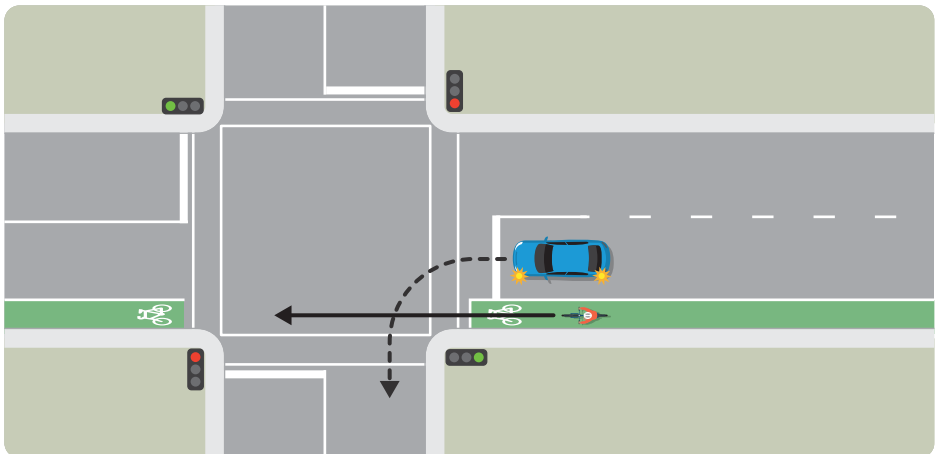

Kia aronuitia

Mēnā e huri whakatematau ana koe, me tautuku ki ngā waka katoa e ahu pēnā ana ki a koe, e huri whakatemauī ana hoki.

Ko aua tikanga tonu rā mēnā e aro atu ana ngā waka e rua ki te tohu whakahaere ōrite, pēnei i te tohu tū, i te tohu tautuku, me ngā rama pūtahi kākārīki.

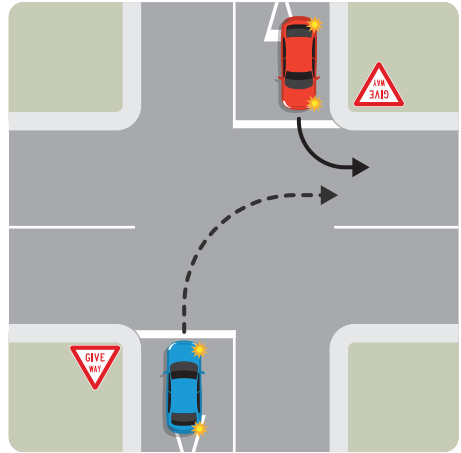
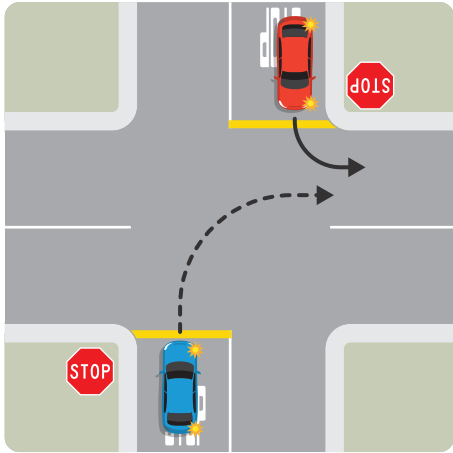

Mēnā e peka atu ana koe i te rārangi waenga i tētahi pūtahi kāore ana whakahaere, me tautuku ki ngā waka e whai tonu ana i te rārangi waenga. E pēnei ana i te mea, ā-ture nei, ko ngā waka ka peka atu i te rārangi waenga ka kīia e huri ana, ahakoa pea he wā ōna e ahu tōtika kē ana, ā, ka ū tonu ko ngā tikanga tautuku.

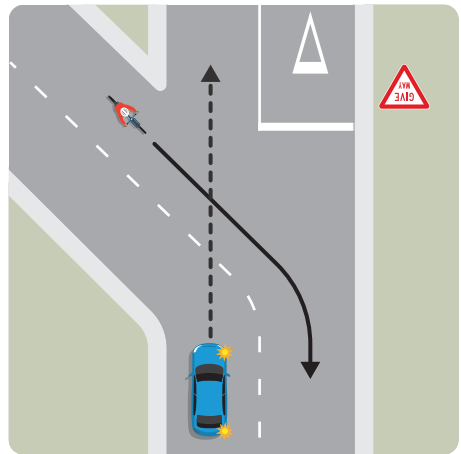
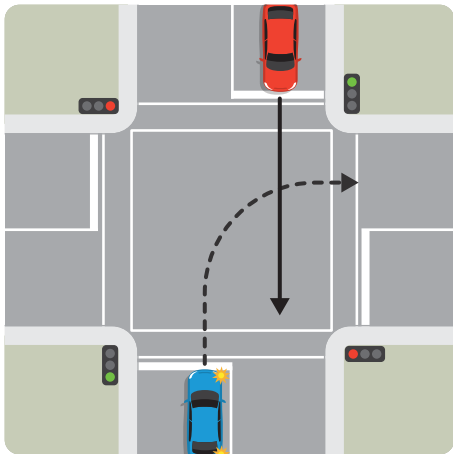

Mēnā e huri whakatematau ana koe, ā, ko te waka hāngai e huri whakatemauī ana, me tautuku ko koe.

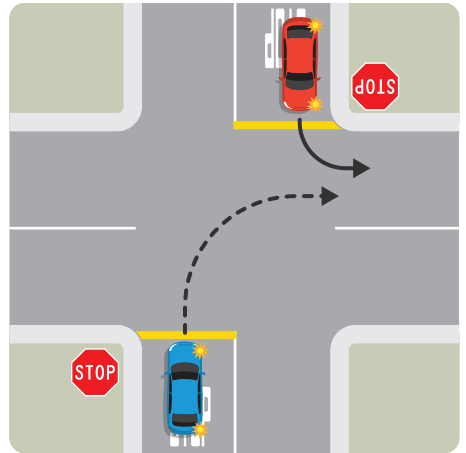
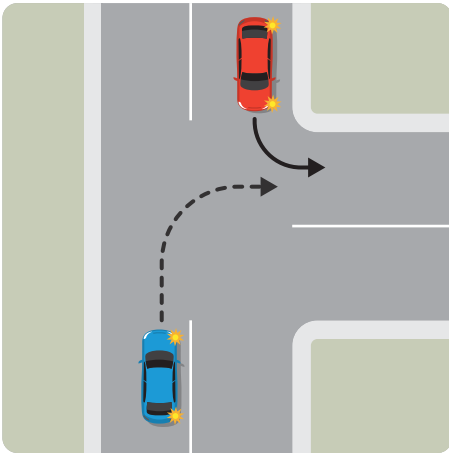
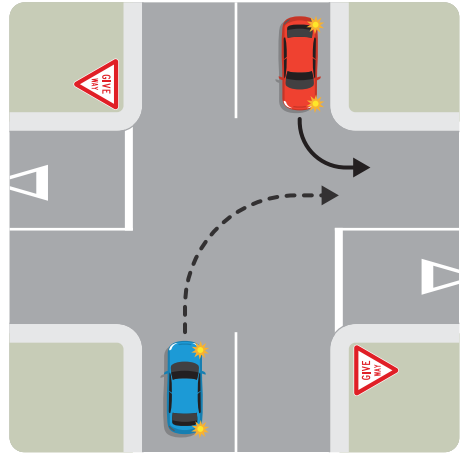
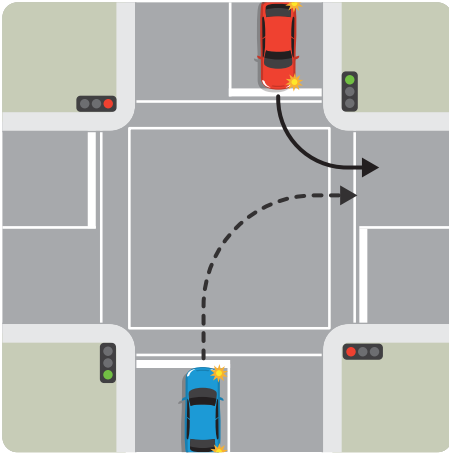

Mēnā kei tētahi whakapaunga rori koe (ko raro o te T), me tautuku ki ngā waka katoa kei te ara moroki (ko runga o te T).

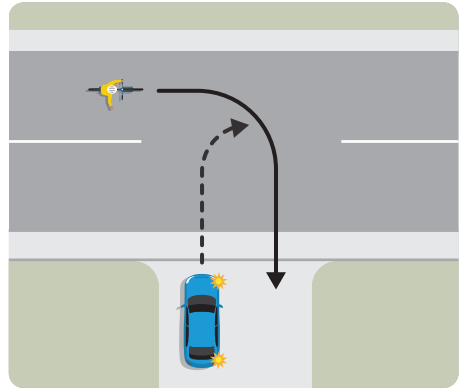
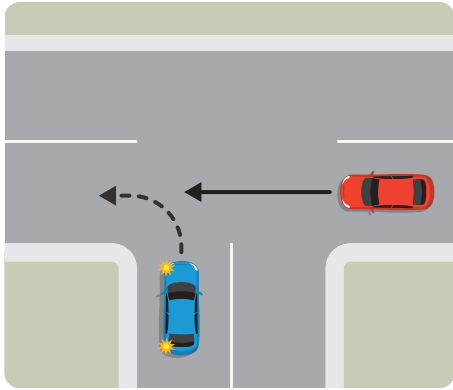

Me mātua tautuku ki ngā waka katoa kei te rori, ki tētahi atu rānei kei te ara hīkoi, kei te ara pahikara, kei tētahi ara matatini rānei.

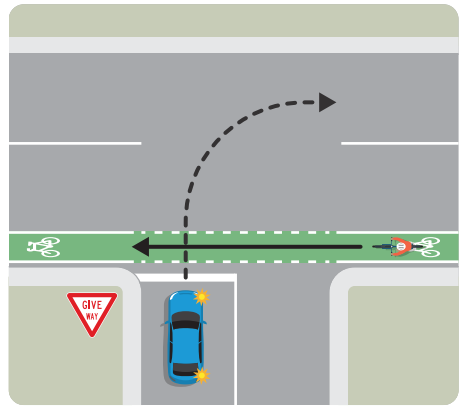
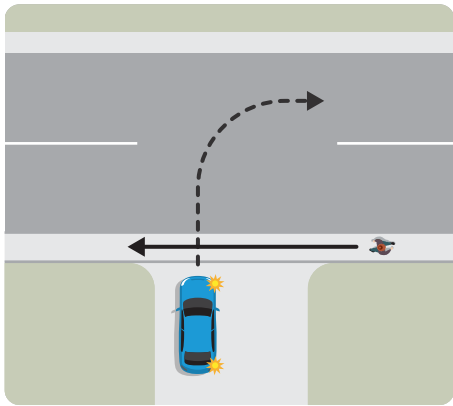

I ngā horopaki kē atu, me tautuku ki tērā kei tō taha matau. Hei tauira, i tētahi pūtahi porotaka, i tētahi pūtahi rānei kāore ana whakahaere, i tētahi ara rīpeka rānei e whakahaerehia ana e te rama pūtahi rori, ka raru ana ngā rama pūtahi, ā, he rama kōwhai e raparapa ana i ngā ahunga katoa.

Kia aronuitia

Ko te tikanga o te tautuku, ko te kaitāwhai i te rori e tautuku atu nei koe, ahakoa he kaihautū waka, he kaieke pahikara, he waehīkoi, he kaitāwhai kē atu rānei i te rori, kāore e mate ki te tū, ki te whakapōturi rānei i tana haere, ki te perori, ki te aha atu rānei hei karo i a koe.

Ngā rama pūtahi

Ka hāngai ēnei ture i te pūtahi ka whakahaerehia e te rama pūtahi – ka kīia hoki ko ngā rama rori.

Ko tā te rama **whero**, me tū koe.

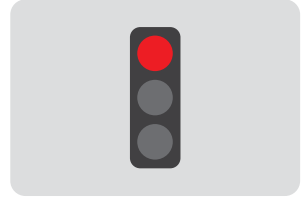

Ko tā te rama **kākāriki**, e āhei ana tō haere mēnā e haumarua ana, waihoki:

- » mēnā e huri whakatemataua ana koe, me tautuku ki ngā waka e ahu pēnā ana ki a koe, e ahu tōtika atu ana hoki, ki ngā waka rānei e huri whakatemauī ana
- » me tautuku koe ki te waehīkoi e whakawhiti ana i te rori. E kapi ana i tēnei ko te hunga kake i te taumatua neneke, i te waka runaruna rānei e whai wīra ana.



Ko tā te rama **kōwhai**, me tū koe, **hāunga** i ngā wā he pērā rawa tō pātata ki te pūtahi e kore nei e haumarua tō whakatū waka. Ko te tikanga o taua tohu, ā kō tonu ake nei ka whero ngā rama.



Ko tā te rama kōwhai e raparapa ana, kua raru ngā rama pūtahi. Ka pēnei ana, me whai ngā ture tautuku.

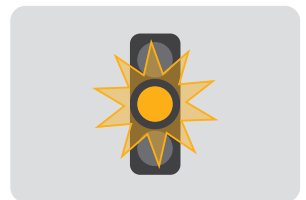

Ngā rama pūtahi pere

Ka whakaatuhia ana te pere i ngā rama pūtahi, ka hāngai ki ngā waka e haere ana i te ahunga e tohungia ana e te pere.

Ko tā te pere **whero**, me tū koe mēnā e whai ana koe i te ahunga o te pere.

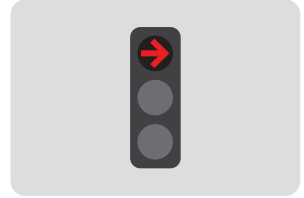

Ko tā te pere **kōwhai**, me tū koe mēnā e whai ana koe i te ahunga o te pere, **hāunga** i ngā wā he pērā rawa tō pātata ki te pūtahi e kore nei e oti i a koe te whakatū tō waka kia haumaruru.







Ko tā te pere **kākāriki**, e āhei ana tō koke mēnā e whai ana koe i te ahunga o te pere, ka mutu, e haumaruru ana te pērā.

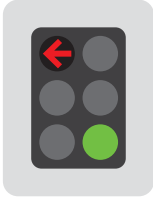

Te mārama ki ngā rama pūtahi

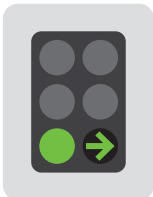
Me ako ngā tikanga o ngā rama pūtahi me ngā pere.

Te rama	Te ahunga waka	Tā te kaihautū
	E huri whakatemaui ana	» Me tū rawa. Hei whakamaru te pere whero i te waehiko e whakawhiti ana i te rori.
	E ahu tōtika ana	» E āhei ana te koke, mēnā e haumarua ana.
	E huri whakatemataua ana	» E āhei ana te koke, mēnā: <ul style="list-style-type: none"> › e haumarua ana, ā › ka tautuku ki ngā waka e ahu pēnā ana ki a koe e ahu tōtika atu ana i te pūtahi, ka mutu › ka tautuku ki ngā waka e ahu ana ki a koe, e huri whakatemaui ana i te pūtahi.
	E huri whakatemaui ana	» E āhei ana te koke, mēnā e haumarua ana.
	E ahu tōtika ana	» E āhei ana te koke, mēnā e haumarua ana.
	E huri whakatemataua ana	» Me tū rawa, hāunga i ngā wā kāore e haumarua te pēnā.
	E huri whakatemaui ana	» E āhei ana te koke, mēnā e haumarua ana.
	E ahu tōtika ana	» E āhei ana te koke, mēnā e haumarua ana.
	E huri whakatemataua ana	» E āhei ana te koke, mēnā e haumarua ana. I tōna tikanga, kua tū kē ngā waka katoa e ahu pēnā ana ki a koe, e huri whakatemaui ana rānei.

Te rama	Te ahunga waka	Tā te kaihautū
	E huri whakatemaui ana	» Me tū rawa.
	E ahu tōtika ana	» Me tū rawa.
	E huri whakatematau ana	» E āhei ana te koke, mēnā e haumarua ana. I tōna tikanga, kua tū kē ngā waka katoa e ahu pēnā ana ki a koe, e huri whakatemaui ana rānei.

Ngā rama pūtahi mō te pahikara, mō te taramu me te pahi

He tohu motuhake i ētahi pūtahi mō te pahikara, mō te taramu me te pahi. Ka kā mai ana ēnei rama, ka āhei te koke a te pahikara, a te taramu me te pahi, **engari katoa ngā waka kē atu me tatari kia kā mai anō te rama kākāriki**. Ko te kaieke i te pahikara, i te kutariki, i te motupaika rānei, e tika ana tana haere i te ara pahi, ka āhei tonu tana koke ka kā mai ana te rama B mā.



Te tautuku i ngā pūtahi porotaka

Ko te pūtahi porotaka, ko tētahi motu i te puku o tētahi pūtahi e haere ai ngā waka katoa mā te taha mauī o te motu. Ko ētahi pūtahi porotaka he iti, he nui rānei, kotahi rānei te ara, he tini rānei ngā ara. Kei te takiwā o te 3 ki te 5, nui atu rānei te tini o ngā rori ka hono atu ki te pūtahi porotaka.

Te pūtahi porotaka ara-kotahi

Ka whakatata ana koe ki tētahi pūtahi porotaka kotahi anake te ara i ia ahunga:

- » me whakapōturi tō haere ka whakatata atu ana ki te pūtahi porotaka, ka takatū ai ki te tautuku
- » me tautuku ki ngā waka katoa ka whakawhiti i tō ara i tō taha matau ka uru atu ana ki te pūtahi porotaka.

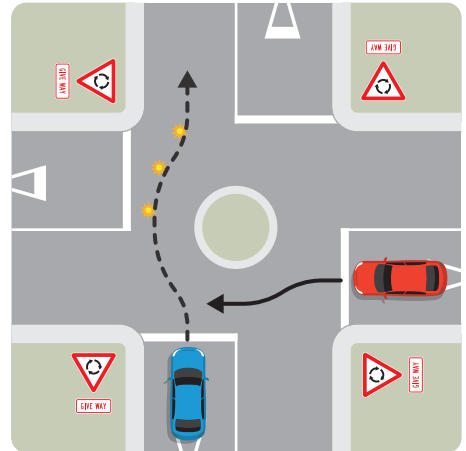

Te pūtahi porotaka ara-tini

He rārangi, he pere anō hoki kua tohua ki te nuinga o ngā pūtahi porotaka, mēnā kei koni atu i te kotahi ngā ara i ia ahunga. Mā ngā tohutanga ara me ngā pere e mōhio ai koe ko tēhea te ara tika hei whai māu. Kāore e ōrite ngā tohu i ngā pūtahi porotaka katoa, nō reira, kia mataara, ina koa i ngā putanga. Ina mate koe ki te whakawhiti ki tētahi atu ara e puta ai i te pūtahi, me tautuku ki ngā waka kei te ara e whai nei koe ki te uru atu.

Ka whakatata atu ana ki tētahi pūtahi porotaka ara-tini:

- » me whakapōturi tō haere ka whakatata atu ana ki te pūtahi porotaka, ka takatū ai ki te tautuku
- » me hou atu ki te ara e tika ana mō te wāhi e ahu nei koe
- » me tautuku ki ngā waka katoa ka whakawhiti i tō ara i tō taha matau, ka uru atu ana ki te pūtahi porotaka.

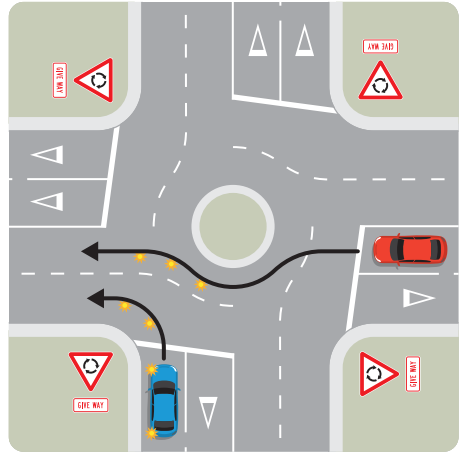
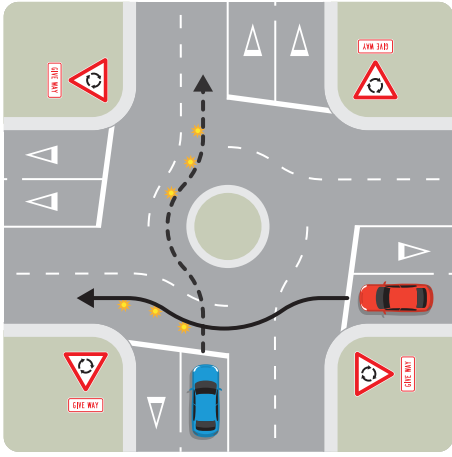

Te tūtohu i te pūtahi porotaka

Mēnā e huri whakatemauī ana koe i te putanga tuatahi o tētahi pūtahi porotaka:

- » me tūtohu whakatemauī ka whakatata atu ana ki te pūtahi porotaka.

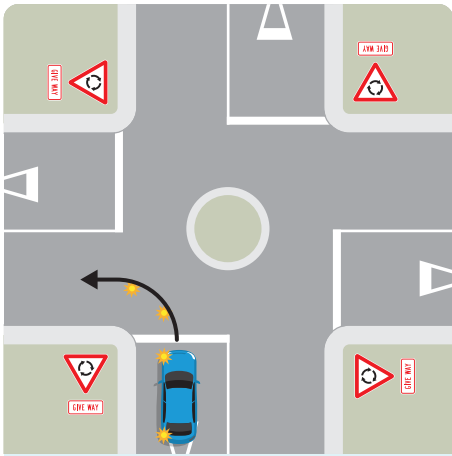

He pūtahi porotaka ara-kotahi

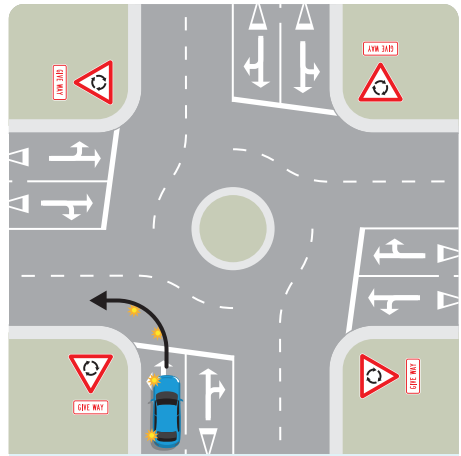

He pūtahi porotaka ara-tini

Mēnā kei tua o te haurua āmīotanga o tētahi porotaka tō haere:

- » me tūtohu whakatematau ka whakatata atu ana ki te pūtahi porotaka
- » me tūtohu whakatemauī ka tohipa ana i te putanga i mua tonu i tērā e puta ai koe.

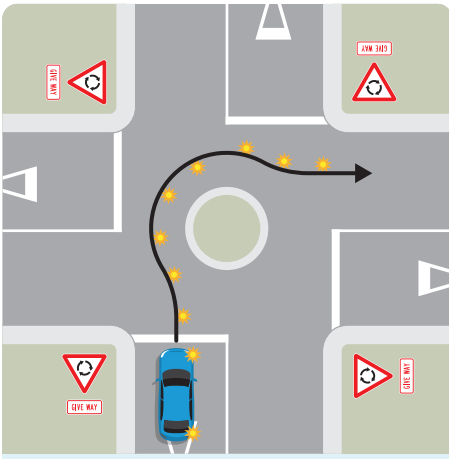

He pūtahi porotaka ara-kotahi

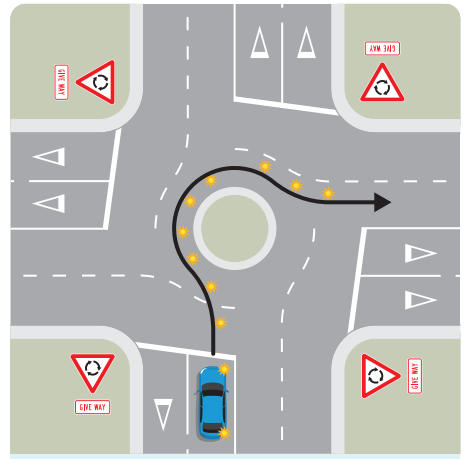

He pūtahi porotaka ara-tini

Mēnā e ahu tōtika atu ana koe i tētahi pūtahi porotaka:

- » kaua e tūtohu ka whakatata atu ana ki te pūtahi porotaka
- » me tūtohu whakatemalaū ka tohira ana i te putanga i mua i tērā e puta ai koe.

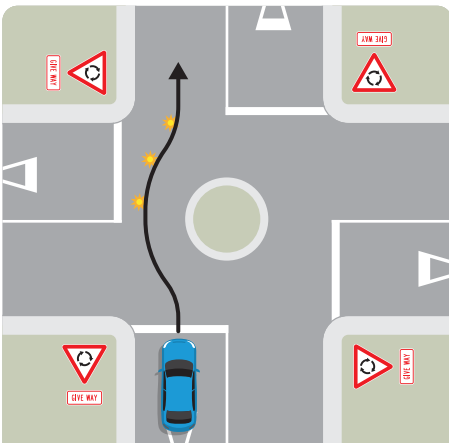

He pūtahi porotaka ara-kotahi

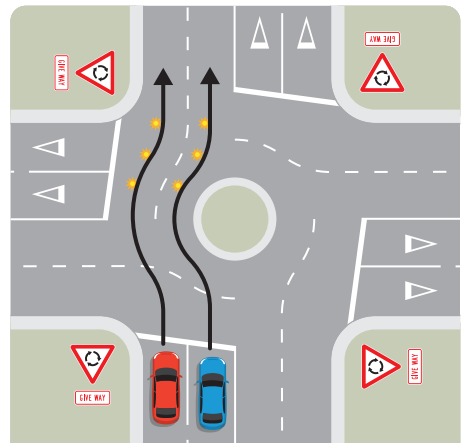

He pūtahi porotaka ara-tini

Kia tūpato i ngā kaieke pahikara, me uaua pea ka mau tonu ki tētahi tūtohu huringa i tētahi pūtahi porotaka, nā reira, e wātea ana i tēnei herenga.

Ngā tohu i ngā pūtahi porotaka

Kei raro iho nei whakaatuhia ai ētahi o ngā tohu ka kitea pea ki te pūtahi porotaka.



Ko tā tēnei tohu he whakamōhio i a koe e whakatata atu ana koe ki te pūtahi porotaka. Me takatū koe ki te tautuku.



Ko tā tēnei tohu, me ū koe ki te taha mauī o te motu koutu, ka whakatata atu ana ki te pūtahi porotaka.



Ko tā tēnei tohu, me whai ngā tikanga tautuku mō ngā pūtahi porotaka.

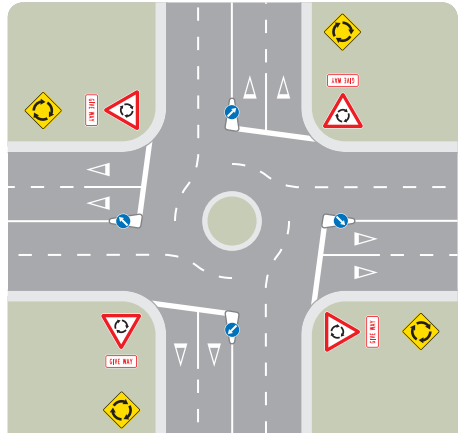

Ko tā te pikitia nei he whakaatu i ngā wāhi ka rite tonu te kitea o ēnei tohu i ngā pūtahi porotaka.

Kia aronuitia

I te pūtahi porotaka, kia mataara ki ngā waka:

- » ka mate pea ki te whakawhiti ki ara kē, e puta ai
- » kāore pea e taea te ū ki tōna anō ara:
 - › he nui rawa nō te hanga, pēnei i te pahi
 - › he tere rawa nō te haere.

Te tautuku i ngā whakawhitinga ara tereina

Ko te whakawhitinga ara tereina, ko te wāhi e whakawhiti ai te rori i tētahi ara tereina. Nō reira, ka hautūngia tō waka i te ara tereina, me te aha, ka tūpono tau ki te ara e haere nei tētahi tereina. Me tūpato koe i ngā wāhi e kitea ana ngā whakawhitinga ara tereina, hei kaupare i tētahi tuinga kino rawa.

Te whakawhiti i tētahi whakawhitinga ara tereina

Anei ētahi o ngā tohu ka kitea pea e koe, ka whakatata atu ana ki tētahi whakawhitinga ara tereina.

Ina kite koe i tētahi o ēnei tohu:

- » me whakapōturi tō haere, ka takatū ai ki te tū
- » ka whakatata atu ana ki te whakawhitinga ara tereina, me āta tiro haere te ara tereina. Me āhua tawhiti tō titiro i te ara tereina, he tere ake nō te haere o te tereina, tēnā i tō ngā waka i te rori i te nuinga o te wā
- » me whakawhiti noa mēnā e mātau pū ana koe karekau he tereina e ahu pēnā ana ki a koe i ngā ahunga e rua, kāore hoki he waka e tū ana ki mua i a koe ki tua o te whakawhitinga.

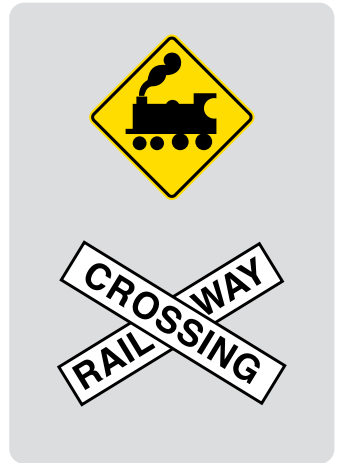

I ngā whakawhitinga ara tereina ka whakahaerehia e te rama, e te pere me ngā pou tauārai

He maha ngā whakawhitinga ara tereina e whakahaerehia ana e ngā tūtohu whero e raparapa ana, ngā pere me ngā pou tauārai.

Me tū koe mēnā kua tīmata te raparapa o ngā rama, te tangi o te pere, te heke mai rānei o ngā pou tauārai.

Kaua e whakawhiti kia hīkina rā anōtia ngā pou tauārai, kia mutu te raparapa o ngā rama, kua ngū anō ngā pere, ā, karekau he tereina e ahu ana ki a koe i ngā ahunga e rua.

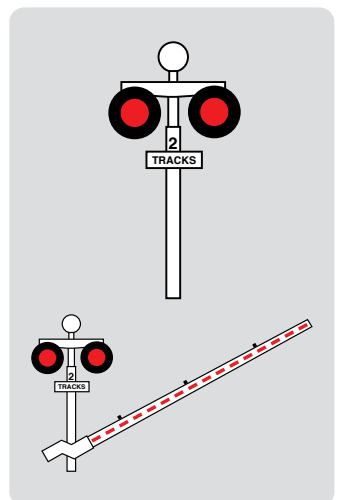

I ngā whakawhitinga ara tereina ka whakahaerehia e te tohu tū, e te tohu tautuku rānei

Ko ngā whakawhitinga ara tereina kāore e whakahaerehia ana e te rama, e te pere, e te pou tauārai rānei, he mea whakahaere kē pea e te tohu tū, e te tohu tautuku rānei.

I ngā whakawhitinga ara tereina ka whakahaerehia e te tohu tū, e te tohu tautuku rānei:

- » me whakaū e mārama ana tō kite i ngā ahunga e rua i te ara tereina
- » mēnā e kitea ana he tohu tū, me tū rawa i mua i te taenga ki te ara tereina - i te nuinga o te wa, kotahi, e rua rānei ngā rārangi kōwhai e tohu ana i te wāhi me tū rā tō waka
- » me whakawhiti noa mēnā e mātau pū ana koe karekau he tereina e ahu pēnā ana ki a koe i ngā ahunga e rua, kāore hoki he waka e tū ana ki mua i a koe ki tua o te whakawhitinga
- » me āta aro mēnā kei koni atu i te kotahi ngā ara tereina.

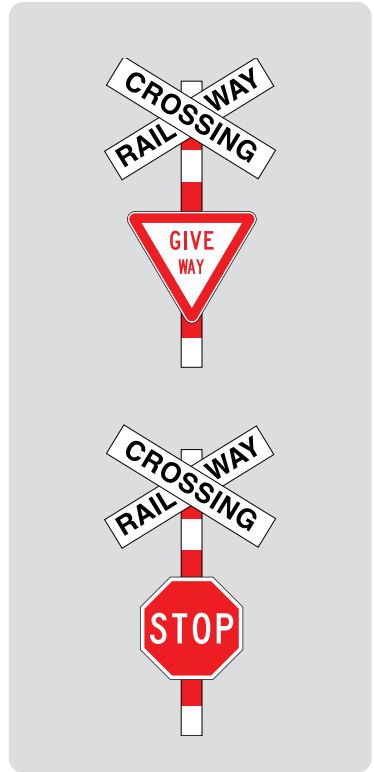

Kia aronuitia

- » Kaua rawa e ngana ki te whakawhiti i te ara tereina mēnā kāore tō waka e ō ki tērā atu taha o te ara.
- » Kaua rawa e tohipa i te waka nā te tereina kē i tū ai.
- » Kaua rawa e ngana ki te whakataetae atu ki te tereina kia tae tōmua ki tētahi whakawhitinga.

Te whai i waka kē atu ka whakawhiti ana i tētahi whakawhitinga ara tereina

Me tūpatou te haere ina whāia ana e koe ko te pahī, ko ngā waka rānei e kawea haere ana i ngā utanga mōrearea, ā, ka whakatata atu ki tētahi whakawhitinga ara tereina, inā hoki, i raro i te ture, ka mate pea rātou ki te whakatū rawa i ō rātou waka i mua i te whakawhiti.

Te tautuku i te arawhiti ara-kotahi

He arawhiti ara-kotahi kei ētahi rori i Aotearoa. I ēnei arawhiti, me tautuku ngā waka e haere ana i tētahi ahunga ki ngā waka e haere ana i tērā atu ahunga. He tohu kei ngā arawhiti ara-kotahi katoa e whakaatu ana ko wai mā me tautuku.

Ngā tohu e whakaatu ana me tautuku koe i ngā arawhiti ara-kotahi

Mēnā me tautuku koe i tētahi arawhiti ara-kotahi, i tōna tikanga ka kitea tētahi o ēnei tohu whakamataara, ngā mea e rua rānei.

Ko tā te tohu whakamataara kōwhai, he taimana te hanga, hei whakamōhio i a koe e whakatata atu ana koe ki tētahi arawhiti ara-kotahi, ā, ko tā te tohu porowhita me tana tapa whero hei whakamōhio i a koe, me tautuku ki ngā waka e ahu pēnā ana ki a koe.

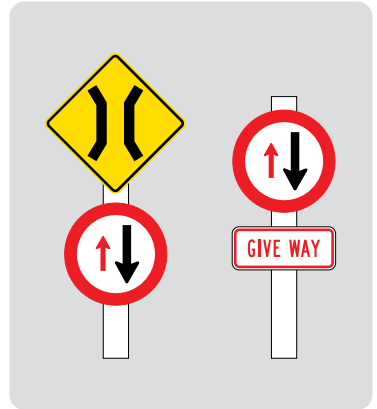

Ko te tohu whakamataara tuarua e whakamahara ana i a koe me mātua tautuku.

Ngā tohu e whakaatu ana ko ngā kaihautū kē atu me tautuku ki a koe i tētahi arawhiti ara-kotahi

Mēnā ko ngā kaihautū kē me tautuku ki a koe i tētahi arawhiti ara-kotahi, ka kitea tēnei tohu, ka whakatata atu ana ki te arawhiti.

Ko tā te pere mā nui i roto i te tapawhā kikorangi hei whakamōhio i a koe, e āhei ana tō koke ki te arawhiti i te tuatahi.

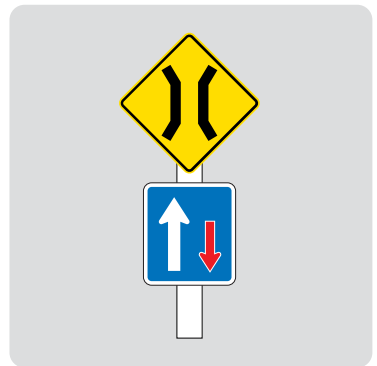

Me whakapōturi tō haere, ka tiro ai mēnā rānei he waka e haere kē ana i te arawhiti i mua i tō koke.

Kia aronuitia

Ka whakatata atu ana ki tētahi arawhiti ara-kotahi, me aro ki ēnei tohu:

- » Ko tā te porowhita whero, me tautuku ko koe.
- » Ko tā te tapawhā kikorangi, ko ngā waka kē atu me tautuku ki a koe.

Te tū me te whakatū waka

Te whakatū waka kia haumaruru ai

Ehara i te mea ko ngā waka e neke ana anake ngā mōreareatanga ka tūpono kitea i te rori. Hei mōreareatanga anō hoki ngā waka kua whakatūria i ōna wā. Nā whai anō he mea nui kia whāia ngā tikanga me ngā aratohu mō te whakatū i te waka kia haumaruru ai.

Ngā tikanga whakatū waka, kia haumaruru ai

E ai anō ki te ture, me mātua whai ko ēnei ture, ka whakatūria ana he waka:

- » Me tūtohu mō te 3 hēkena, roa atu rānei, i mua i te whakapōturi kia whakatūria te waka.
- » Me whakatū te waka kia whakarara ai te noho ki te rori, me te ū hoki ki te taha mauī rawa, hāunga i ngā wā e whakatūria ana tō waka ki tētahi wāhi e whakaaetia ana te whakatū koki nei i te waka. Ka kitea he rārangi i te rori, he tohu rānei e whakaatu ana ki hea whakaaetia ai tō whakatū koki nei i tō waka. I te nuinga o te wā, me koke whakamua e hou ai koe ki tētahi tūnga koki.
- » Me whai kia wehe mārika i te rori ka tū ana, ka whakatūria ana rānei tō waka ki tētahi rori e horo ana te haere o ngā waka.
- » Me mātua whakaū kāore he waka e tohipa ana, kāore he kaieke pahikara, kāore rānei he waehikoi e pātata ana i mua i tō whakatuwhera i te kūaha.
- » Kia tūpato i a koe e puta ana i tētahi tūnga waka. Kei wareware te
 - › whakaū kāore he waka atu anō e pātata ana
 - › tūtohu mō te 3 hēkena, roa atu rānei, i mua i te koke.
- » Kia kua rawa tētahi waka e whakatūria ki te rori i ngā hāora e pōuri katoa ana mēnā kāore e mārāma ana te kitea ōna e ngā kaitāwhai kē atu i te rori. Nō reira, i tōna tikanga me miramira e ngā rama rori, me whakakā rānei e koe ngā rama hikuwaka, me te rama tahataha i mua o te waka kei te taha e pātata katoa ana ki te puku o te rori.
- » Ko te waka taimāmā, e whai kāraho papatahi ana anō hoki, ka whakatūria ki te rori tonu i te pō, me whai rama whero i muri:
 - › i te taha o te waka e pātata katoa ana ki te puku o te rori
 - › e mārāma ana te kitea ōna ina 100 mita te tawhiti.

Ngā aratohu mō te whakatū waka, kia haumarū ai

Mā te whai i ēnei aratohu, kāore tō waka e koke whakamua, e haere whakamuri rānei ka whakatūria ana ki tētahi rori paripari.

- » Me huri ngā wira o mua kia anga ai ki te taparori.
- » Me waiho tō waka ki te nihowhiti whakamuri mēnā he waka nihowhiti ā-ringa, ki te nihowhiti tū rānei mēnā he waka nihowhiti aunoa.
- » Karawhiua te whakatū ā-ringa

Mēnā kua tohua ngā tūnga koki, kia koki hāngai ai ki te taparori, māu anō e kōwhiri mēnā rānei ka hou whakamuri atu, mēnā rānei ka koke whakamua atu ki te tūnga. Mā te haere whakamuri e mārāma ake ai te tirohanga ka puta ana i te tūnga waka.

Te haumarutanga

Mēnā he tini ngā waka i te rori, ko te painga atu kia puta koe i tō waka mā te taha e tawhiti ana i ngā waka.

Ngā wāhi kāore e whakaaetia te whakatū waka

Arā ētahi wāhi kāore e whakaaetia ana te whakatū waka. Ka tūpono hāmenehia, ka tōia atu rānei tō waka ina whakatūria ki ēnei wāhi. Me kaua rawa e whakatū i tō waka, e tū rānei:

- » ki te taha matau o te rori, hāunga i te tiriti ahutahi
- » mēnā ka aukatingia te haere a kaitāwhai kē atu i te rori, tae atu ki te waehiko
- » kia pātata ki te koki, ki te kōpiko, ki te puke, ki te motu rori, ki te pūtahi rānei, mēnā mā te pērā, ka aukatingia te tirohanga o tangata kē atu i te rori
- » ki te rori, mēnā ka taea e koe te whakatū tō waka ki te taitapa, ki tua rānei o te rori, tē whakakino ai i te pātītī, i ngā māra rānei - hāunga i ngā wāhi kei reira rā he tohu 'NO PARKING'
- » ki tētahi ara hiko, ki tētahi motu rori, ki tētahi tūnga tēkehi, ki tētahi tūnga pahi rānei ka tohungia ki te tohu anake
- » ki tētahi wāhi e pātata ake ana i te 6 mita ki tētahi pūtahi, ki te taha urunga o tētahi whakawhitinga waehiko, ki tētahi tūnga pahi rānei kua tohua noatia ki te tohu
- » ki tētahi wāhi i mua rānei, e pātata ake ana rānei i te 1 mita ki tētahi urunga waka
- » ki te taha tonu o tētahi atu waka kua whakatūria kētia - arā, me kaua rawa e whakatū waka kia takirua ai te tū
- » ki ngā rārangi tūnga kore - ko ngā rārangi kōwhai nakunaku e pātata ana ki te taparori
- » ki ngā wāhi e mea ana ngā tohu me kaua rawa e tū, e whakatū rānei tō waka
- » ki ngā wāhi e mea ana ngā tohu hei whakamahi taua wāhanga o te rori mā te pahi, mā te tēkehi, mā te waka ngaio anake e kawea utanga
- » ki tētahi ara pahikara
- » ki tētahi ara pahi, ki tētahi ara wātea motuhake rānei i waenga i ngā hāora e whakaatuhia ana i te tohu

- » ki tētahi pūhono wai patuahi, he mea tohu ki te tapawhā me te porowhita kōwhai, mēnā kāore tētahi kaihautū e whai raihana ana, ka taea te waka te neke e noho atu ki te waka
- » ki tētahi wāhi e pātata ake ana i te 50 henemita ki tētahi pūhono wai patuahi, ki te kore e nohoia e tētahi kaihautū whai raihana, e taea ana e ia te waka te neke
- » ki waenga i tētahi pere kōwhai e tohu ana i te ahunga o tētahi pūhono wai patuahi me te taparori, mēnā kāore tētahi kaihautū e whai raihana ana, e taea ana e ia te waka te neke, e noho atu ki te waka.



He tānga rori mō te pūhono wai patuahi



E tohu ana i te ahunga ki te pūhono wai patuahi

Me whai whakaaro ki tāngata kē atu, ka whakatūria ana tō waka. Me rawaka te wāhi wātea i waenga i tō waka me waka kē atu kua whakatūria, e māmā ai te whai wāhi atu.

Ngā tohu whakatū waka

Me whai koe i ngā tohu whakatū waka katoa.

He taurira o te tohu whakatū waka

Ko ngā tohu whakatū waka, he whero ngā tapa, e tohu ana kāore e āhei tō tū ki reira, ki te kore e whakaatuhia he wā atu anō e pai ana.

Anei ētahi taurira o te tohu whakatū waka, me ngā tikanga.



Kaua rawa e tū ki konei i waenga i ngā hāora e whakaatuhia ana i te tohu. Ki te pērā koe, ka tōia atu tō waka. Ka mate koe ki te utu i te nama tō e riro anō ai i a koe tō waka



Kaua rawa koe e tū, kia hipa rā anō te tawhiti e whakaatuhia ana i te tohu



Kāore e āhei tō tū ki konei, ahakoa te wā



E āhei ana tō tū ka tohipa ana koe i te tohu



Kāore e āhei tō tū i te ahunga e tohua ana e te pere i waenga i ngā hāora o te 8 i te ata me te 6 i te pō



Ko te pahi anake tērā e āhei ana tana tū ki konei. Kāore e āhei tā tētahi atu momo waka tū ki konei, ahakoa te wā

Ka ū tonu ko ngā here o ngā tohu whakatū waka i waenga i te 8 i te ata me te 6 i te pō, hāunga i ngā rā whakatā tūmatanui, mēnā kāore e whakaatuhia ana ētahi hāora kē atu.



Ko te tau i raro i te pū P e tohu ana i te roa ā-mēneti nei e whakaaetia ana kia whakatūria tō waka

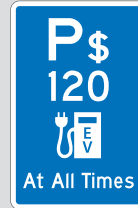

E whakaaetia noatia ana kia whakatūria ko ngā waka hiko (EV) ki konei, engari kia kaua e roa ake i te 120 mēneti



Me kite tētahi tīkiti i te matapihi o te waka ina whakatūria tō waka ki konei



E whakaaetia noatia ana kia whakatūria ko ngā motupaika ki konei

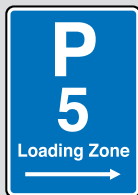

E whakaaetia ana te whakatū waka ki konei e pai ai te tango atu i ngā utanga, e tukuna ai rānei ngā pāhihi, engari, kia kaua e roa atu i te 5 mēneti te waka e noho kau ana



E whakaaetia noatia ana kia tū ngā waka utanga ki konei e pai ai te tango atu i ngā utanga, e tukuna ai rānei ngā pāhihi, engari, kia kaua e roa atu i te 5 mēneti te waka e noho kau ana

Ngā tūnga waka mō te hunga whaikaha

He mea whakarite ngā tūnga ki reira kitea ai ēnei tohu, e ngāwari ai tā te hunga whai puka whakaaetanga mō ngā tūnga waka whaikaha whai wāhi atu ki ngā wāhi pēnei i te hokomaha, i te whare pukapuka, me te whare hapori.

E āhei ai tō whakatū i tō waka ki konei me kite tētahi puka whakaaetanga tūnga whaikaha i te matapihi o mua o tō waka. Ki te kore, ka tūpono whiua koe, ka tōia atu rānei tō waka.

E whai mōhiohio ai ki te ara e riro ai i a koe tētahi puka whakaaetanga, otirā ki ngā āhuatanga motuhake e hāngai ana, whakapā atu ki a CCS Disability Action, ki 0800 227 2255, toro atu rānei ki [ccsdisabilityaction.org.nz](https://www.ccsdisabilityaction.org.nz)



E whakaaetia noatia ana kia whakatūria ngā waka e kitea ana he puka whakaaetanga tūnga whaikaha ki konei



Te whakaaetanga tūnga whaikaha

Te aukati i ngā pūtahi me ngā whakawhitinga waehīkoi

Mēnā he nui ngā waka i te rori, ka tere tupu he rārangi waka. Ina mau koe ki tētahi rārangi waka, he mea nui kia kaua koe e aukati i ngā pūtahi, i ngā ara tereina, i ngā whakawhitinga waehīkoi rānei.

Me kaua koe e uru, e ngana rānei ki te whakawhiti i te pūtahi, i te whakawhitinga ara tereina, i tētahi wāhi rānei e whakahaerehia ana e te rama tūtohu waehīkoi, mēnā kāore he wāhi wātea mō tō waka ki tērā atu taha.

I te pikitia tuatahi, me kaua te waka **A** e uru ki te pūtahi i te mea kāore he wāhi wātea ki tērā atu taha o te pūtahi. E pai ana tā te waka **B** me te waka **C** uru ki te pūtahi i te mea e rawaka ana te wāhi wātea ki tērā atu taha o te pūtahi.

E aukati ana te waka i te pikitia tuarua i te wāhi e whakahaerehia ana e te rama tūtohu waehīkoi.

Ka huri whakatematau ana i ngā rama pūtahi, e āhei ana to uru atu, me tō tū ki tētahi pūtahi, mēnā kāore he waka atu anō e tatari ana kia huri whakatematau ai. Ka haumarua ana, e āhei ana tō huri, ahakoa pea kāore e kitea tonutia ana te rama kākāriki ka wātea ana koe ki te huri.

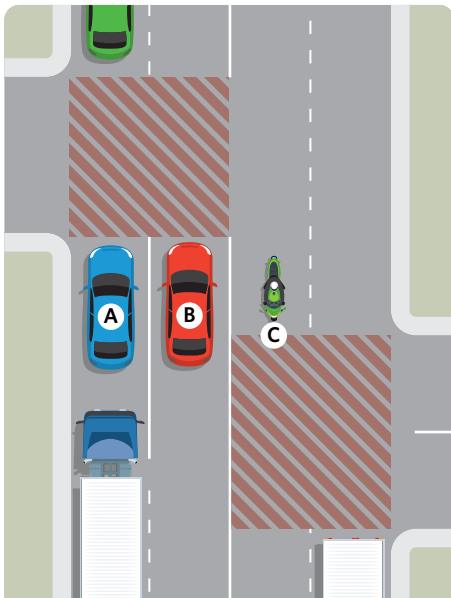

Kāore e aukati ana i te pūtahi

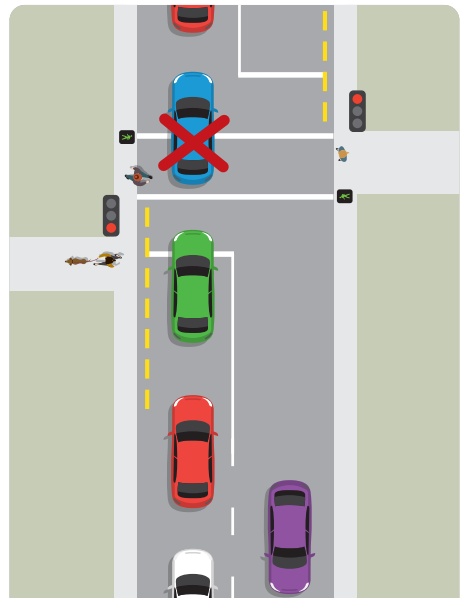

E aukati ana i te wāhi e whakahaerehia ana e te rama tūtohu waehīkoi

Ka huri ana te taiao hautū

Ākona me pēhea e hautū kia haumaruru tonu ai, ina mōrearea ake te taiao hautū i tērā e kitea ana i te nuinga o te wā.

Te hautū i te huarere kino

Mēnā e ua ana, e hukarere ana rānei, e pūkohu ana rānei, e tio ana rānei te rori, ka mōrearea ake te taiao hautū. Me tino tūpato tō hautū waka.

He kupu āwhina mō te hautū i te huarere kino

Mātaihia tō waka

He mea nui kia kaha ngā whakatumu, ngā taea, ngā tārakerake, ngā rama, me te wāhi ki te urungi, i ngā wā e mākū ana. Me rite tonu tō mātai i tō waka kia mōhio ai e kaha ana te katoa.

Te whakahāngai i te āhua o tō hautū

Ka tino mania te rori e mākū ana, e hauhunga ana, e tio ana rānei. Me whakarua ake tō tawhiti whaiwhai, inā hoki me roa ake te wā kia whakatūria ai te waka i tētahi papa mania. Whāia te ture 4-hēkena kia whakarua ake i tō tawhiti whaiwhai – tirohia te whārangi 56. Ka mania kē atu te rori i muri tata tonu i te tīmatanga o te ua, ā, ka mania tonu kia oti rā anō tā te ua horoi atu i te hinu i te rori.

Aronuitia tō tirohanga

Ko tō tirohanga, arā, ko te tawhiti e kite nei koe, ka tino reherehu i te ua, i te hukapapa, i te kohu rānei. Ka piki te tūpono o te tūkinga waka. E pai ake ai tō tirohanga, me whai kia mā tonu ngā matapihi me ngā whakaata katoa. Kaua e tuku kia pūkohu haere ngā matapihi – whakakāngia te whakapūahoaho, huakina rānei tētahi matapihi.

Me āta tumu

Mēnā kāore ō tō waka whakatumu pūnaha raka-kore (ABS), kaua e mārō rawa te pato i ngā whakatumu, ka mākū ana. Ka mōrearea pea te paheke haere. Engari, me āta pato kē i ngā whakatumu.

Mēnā he whakatumu ABS ō tō waka, kaua rawa e pato i ngā whakatumu i te wā o te ohotata. Kia mārō tonu te pei i te whakatumu, ka urungi ai i te waka

kia haumaru rā anō ai. Kua e māia rawa tō hautū i runga noa i te mōhio he ABS ō tō waka.

Te wairehu

Kia mataara ki ngā waka e ahu pēnā ana ki a koe, inarā ko ngā taraka nui, inā hoki ka mōnenehu pea tō matapihi o mua ki te wairehu, ka tohipa ana i a koe. Ahakoa pea kua mao te ua, mēnā e mākū tonu ana te rori, ka mate tonu pea koe ki te whakamahi i ngā tārakerake ka whakatata atu ana te taraka ki a koe.

Te whakapōturi

I tētahi rori mākū, ina ū koe ki te paetere, ka tere rawa pea te haere e ai anō ki ngā āhuatanga o te wā. Ka māmā noa pea te paheke haere, ka mākū ana, inarā i ngā wā me ohotata te whakapōturi haere, nō reira, **kia āta haere**.

Kimohia ngā rama ihuwaka i te kohu

Mēnā ka hautū koe i te kohu, ko ngā rama ihuwaka e mārama taiahoaho ana, ka whakaata kē te aho ki a koe. Kimohia ō rama – ka mārama ake te kite.

Kua e whakakā noa i ngā rama tū. Me uaua ka kitea e te kaihautū e ahu ana ki a koe, me uaua hoki ka mārama ake tāu e kite ana.

He aho whānui tō ngā rama kohu o mua, e anga whakararo ana, he mā, he kōwhai rānei te tae, e mārama ake ai tō kite i te kohu, i te hukapapa rānei.

He aho whero whānui tō ngā rama kohu o muri, e anga whakararo ana, e mārama ake ai te kitea ōu i te hukarere, i te kohu rānei e ngā waka e whai ana i a koe. Me whakamahi noa ngā rama kohu i ngā wā e tino rehurehu ana te tirohanga, pērā i ngā wā e kohu ana, e hukarere ana rānei.

He hara te whakamahi i ngā rama kohu i ngā wā e pai katoa ana te huarere, tae atu hoki ki ngā hāora o te pō.

Te hautū i te pō

Mō āhea whakamahia ai ngā rama ihuwaka

Me mātua kā ngā rama ihuwaka o tō waka:

- » e 30 mēneti whai muri i te tōnga o te rā, tae noa ki te 30 mēneti i mua i te aonga ake o te rā
- » i ngā wā kāore e mārama ana te kitea o tētahi tangata, o tētahi waka rānei, 100 mita te tawhiti atu i a koe.

Kaua rawa e hautū, ko ngā rama tū noa e kā ana.

Hei whakamōhio: ko ngā rama tū, ka mōhiohia hoki hei rama tūnga.

Mō āhea kimohia ai ō rama ihuwaka

Me mātua kimo ngā rama ihuwaka o tō waka:

- » ka ahu pēnā ana ētahi waka kē atu ki a koe, kia kore koe e whakamatapō i te kaihautū e ahu pēnā ana ki a koe
- » ka whaiwhai ana i waka kē atu
- » ka whakatata atu ana ki tētahi pirihiimana e tohutohu ana i ngā waka
- » ka tū ana tō waka.



Te kimo i ngā rama ihuwaka mō tētahi waka e ahu pēnā ana ki a koe



Te kimo i ngā rama ihuwaka ka whāia tētahi atu waka

Mēnā e rawaka ana ngā rama i te rori, i tōna tikanga ka pai noa tō hautū, ko ngā rama ihuwaka kua kimohia, i te roanga o te haere.



Kia aronuitia

Kia mōhio mai, i te pō, i te mea ka nui te whakaataata o te nuinga o ngā tohu rori, ka whitikina ana e ō rama, ka pōhēhē pea koe e tawhiti ake ana tō tirohanga, i tērā e taea ana. Me āta haere i ngā rori i te pō, inarā i ngā rori e tauhou ana ki a koe.

Te tere o te haere i te pō

Ko te tere o tō haere i te pō, me haumaruru tonu. Nō reira:

- » i tētahi rori whai ara, me oti tō whakatū i tō waka i te wāhanga wātea o te rori e kitea ana e koe i mua tonu i a koe
- » i tētahi rori ara-kore, me oti tō whakatū i tō waka i tētahi haurua o te wāhanga wātea o te rori e kitea ana e koe i mua tonu i a koe.

He kupu āwhina, kia haumaruru ai te hautū i te pō

He mōrearea ake te hautū i te pō, tēnā i te hautū i te rā. E haumaruru ake ai tō haere i te rori i te pō:

- » me whai kia mā tonu te matapihi o mua me ngā rama
- » kua rawa e mau mōhiti uriuri
- » me aronui ki te waehikoi me te kaieke pahikara - me uaua ake ka kitea i te pō
- » me tū, ka whakatā ai, mēnā e hiamoe ana
- » kua e whakamatapō i kaihautū kē atu ki ngā rama ihuwaka o tō waka - me kimo kē ngā rama ihuwaka ka ahu pēnā atu ana te waka ki a koe, ka whai ana rānei koe i tētahi atu waka
- » ina whakamatapōhia koe e ngā rama o ngā waka e ahu pēnā ana ki a koe:
 - › me whakapōturi, me whakatū rānei tō waka
 - › kia mau tonu tō titiro ki te taha mauī o te rori, kia kore ai koe e tiro tōtika ki te aho
- » me hautū i tētahi paetere e mārara tonu ai tō kite i te tawhiti o te rori i mua ka tāwhaitia e koe i te 2 hēkena, roa atu rānei
- » i ngā wāhi karekau he rama rori, me whākana ngā rama ihuwaka i ngā wā e tika ana, hei whakaroa i te tawhiti e kitea ana e koe.

Whakamahia he tohu hei ārahi i a koe, ka hautū ana i te pō

He tini ngā rori e whai whakaataata ana, e whai pou ārahi ana hoki hei āwhina i a koe ki te pānu i te rori i te pō. Kei raro iho nei ko ētahi taurira.



He pou tohu i te taha mauī o te rori



He pou i te taha matau o te rori e tohu ana i tētahi hurihanga whakatemaū



Te taha mauī o te arawhiti



Te taha matau o te arawhiti

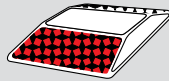

Te taha mauī o te rori



Te rārangi waenga

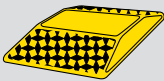

Kaua e tohipa

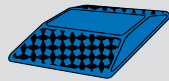

He pūhono wai patu ahi

Ngā mahinga rori

He rite tonu tā ngā tira whakatika rori mahi i ngā rori kia pai tonu ai te hanga. Nā whai anō, he wā ōna ka tūpono koe ki te waka taimaha, ki te mīhini, ki ngā kaimahi hoki i te rori, me te aha, me tūpatō.

Ka mōrearea hoki pea te mata tonu o te rori, ka whakatikahia ana, inā hoki ka torehapehape pea, kua whai kiri hou rānei pea.

Ka kitea ana he tohu mahinga rori, me whakapōturi te haere i ngā wā katoa, ka takatū ai ki te whakatū i tō waka.

Whāia ngā tohu

Mēnā he mahinga rori kei tua, ka mārama te kitea o ngā tohu i ngā wā katoa.

Me whakapōturi tō haere, ka pānuī ai i ngā tohu. Mā reira e takatū ai koe ki ngā mōreareatanga ka tau ki mua i a koe ā kō ake nei.

E whakaatuhia ana i konei ko ētahi tohu e rua he rite tonu te whakamahia hei tohu i ngā mahinga rori.

Nā te mea ka mōrearea pea te hautū i ngā mahinga rori, i te kiri hou rānei, he rite tonu te whakatūria o ētahi tohu paetere rangitahi. Me kua rawa e tere ake tō haere i tērā e tohua ana i te tohu paetere rangitahi.

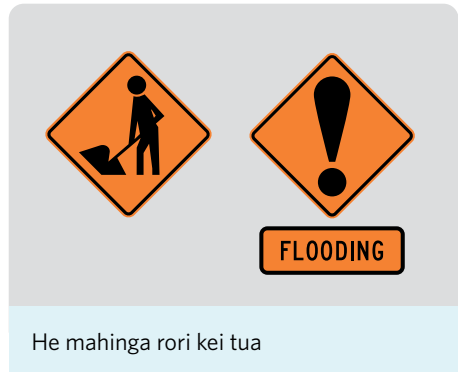

Whāia ngā tohutohu

He wā ōna ka mate pea ngā tira whakatika rori ki te whakatū i ngā waka. Ka whakamahi pea rātou i ngā rama tohu rangitahi, i ngā tohu STOP/GO rānei ka puritia ki te ringa, e tutuki ai.

Whāia ngā tohutohu katoa i a koe, kei tūpono hua ake he tuinga kino.

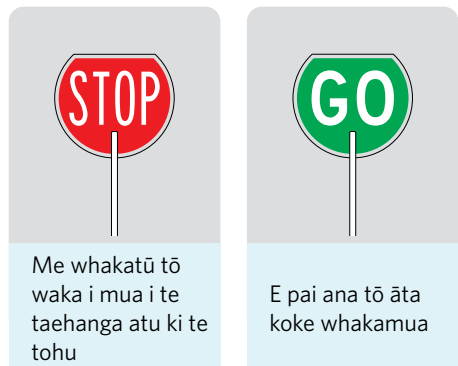



Kia aronuitia

Ka tūpono hua ake he tuinga, ka pīhia ana e ngā kaihautū ngā tohu whakamataara mō ngā mahinga rori me ngā paetere rangitahi. Kauga e pīhia ēnei tohu whakatūpato. Tē aro i a koe he aha hoki kei tua, nō reira, kia āta haere.

Ngā tohu autaki

Ka kapi ana, ka whakapaipaihia ana rānei tētahi rori, ka kitea pea he tohu autaki e whakaatu ana i tētahi ara kē e tohipa ana i te aukatinga.

Me whai ngā tohu ārahi, ā, me takatū hoki ki ngā tohu rā ka whakatata atu ana, ka wehe ana rānei i tētahi pūtahi. Arohia te auaha me te tae o te waitohu i ngā tohu autaki inā hoki, ka whakawhiti pea tētahi ara autaki i tētahi atu.



Ngā tohu whakawhiti ara

Ka whakapaipaihia ana ngā rori, ngā ara rānei, he rite tonu te whakamahia o tētahi taraka whai papa pānui, e kīia nei ko te 'attenuator'. Ko tāna, he tohutohu i ngā waka kia hou atu ki tētahi ara tuwhera i mua i te taenga atu ki te mahinga rori. Me whakapōturi tō haere, ka whai ai i te pere.



Te kāpō hihirā

Ka tūpono hua ake te kāpō hihirā i ngā wāhanga katoa o te rā, heoi, e tūpono nui ana ka puta i te aonga ake, i te tōnga rānei o te rā, ka pā ana ngā hihi o te rā ki te matapihi o mua o tō waka mā tētahi koki e tata ana ki te paerangi. Ki te pēnei, ka uaua, ka kore rawa rānei tō kite atu. He mōreareatanga nui tēnei, ka hautū ana. Whāia ēnei aratohu kia kore ai e hua ake he tukungā waka.

Te whakaheke i te mōreareatanga o te kāpō hihirā

- » Kia takatū ki te kāpō hihirā ka hautū ana i te aonga ake, i te tōnga rānei o te rā, inarā ka huri ana, ka haere hāngai ana rānei ki te rā.
- » Me tino tūpato i te hōtoke, i te wā e nui ake ana te tūpono ka hua te kāpō hihirā, inā hoki, kei te wāhi o raro kē o te rangi te rā e noho ana.
- » Me whai kia mā a roto, a waho anō hoki o te matapihi o mua. Ka kino kē atu ngā pānga o te kāpō hihirā i te puehu me te paru.
- » Me mau mōhiti ka hautū ana, ā, ko te rā e wero ana i ō karu.
- » Whakamahia ngā ārai rā o tō waka hei ārai i te rā.
- » Ki te pāngia koe e te kāpō hihirā, ko te mea haumaruru katoa pea ko te whakatū i tō waka, ka tatari ai mō ētahi mēneti torutoru kia waia haere ai ō karu, kia pai ake ai rānei te tirohanga.
- » Kia tūpato mēnā kua rere te hukapapa, ā, e mārāma ana te rangi - ko te kāpō pea te hua ka whitikina ana te hukapapa e te rā, ka mutu, ka āhua ōrite ngā pānga o te pērā ki ō te kāpō hihirā.



Te kiri rori

E toru ngā momo kiri matua e whakamahia ana i ngā rori me ngā huarahi matua:

- » ko te piaone uriuri
- » ko te pia-kirikiri
- » ko te piakore.

Kia mataara ki ngā panonitanga ki te kiri rori. Ka mate pea koe ki te panoni i te āhua o tō hautū kia hāngai ai ki te momo kiri rori e haere nei koe, inā hoki, ka rerekē ngā pānga o ngā momo kiri rori ki te āhua o te whakahaere i tō waka.

Te piaone uriuri

Ko te piaone uriuri, ka karangahia hoki ko te 'bitumen', he maheni, he uriuri hoki te hanga, ā, kāore e hoihoi rawa ka hautū ana i tēnei momo rori. He rite tonu te whakamahia ki ngā rori ka kapi i te waka me ngā kōpiko nā te mea ka kaha tonu, ahakoa te ngāhorohorotanga ka hua i ngā waka e tumu ana.

Autaiā tonu ana te āhua o te rapa o te piaone uriuri, engari, ka ngoikore ake te taha ki te āraitanga paheke ka mākū ana. Nō reira, me whakapōturi tō haere, me tūpato hoki ka hautū ana i te piaone uriuri, ka ua ana.



Te pia-kirikiri

Ko te pia-kirikiri ko tētahi papanga toka e angiangi ana, kua whakaūngia ki te tā. He taratara te hanga mēnā e kounga ana, engari, ka mania haere pea ka tawhito haere ana, ka kaha ana anō te haerehia ōna e te waka.

Ka ngoikore ake te taha ki te āraitanga paheke o te pia-kirikiri e ngāhorohoro haere ana, nō reira kia mataara ki ngā wāhanga mania i a koe e hautū ana.

Me whakapōturi te haere i ngā rori kātahi nei ka ūhia ki te pia-kirikiri. Arā pea ētahi wāhanga e tangatanga ana ngā konga, ā, mā reira rā e nui ake ai te tūpono ka paheke.

Ngā kiri piakore

Ko ngā rori kiri piakore ka hangaia ki te uku, ki te pungapunga, ki te kirikiri rānei, ka kīia hoki he metara tangatanga i ōna wā.

Nā te mea e tangatanga ana te kiri o te rori, ka neke pea i raro i ō wīra, ā, he iti noa iho te parenga paheke. Ka perea ake pea he kohatu tangatanga e riwha ai, e pakaru ai rānei te matapihi o mua. Kia āta haere i ngā rori kirikiri, ka whakahāngai ai i tō paetere kia pai ai ki te āhua o te taiao hautū.

Kia āta haere i ngā wā e maroke ana a waho, kei mōnenehu haere tō tirohanga i te puehu ka tutūngia e ngā waka i mua i a koe. Me whakaroa ake te tawhiti whaiwhai, kia tawhiti ai te noho i te kapua puehu.



Ngā mōreareatanga me ngā take ohotata

Ka tūpono mōrearea te hautū waka, inarā ka whai wāhi ana ētahi mōreareatanga kē atu. Ākona me pēhea e arohia ai ngā mōreareatanga, me pēhea hoki e karo ai i ngā tuinga waka.

Te aro ki ngā mōreareatanga

Hei kaihautū waka, he rite tonu tō tūpono atu ki ngā mōreareatanga i te rori. Ko te mōreareatanga, ko tētahi mea, ko tētahi āhuatanga rānei e tūpono mōrearea ana.

E kapi ana i ngā mōreareatanga ko:

- » ngā pūtahi – tae ana ki ngā ara urunga
- » ngā kōpiko me ngā hurihanga i te rori
- » ngā whakawhitinga waehīkoi
- » te tūranga, ngā nekenekhangā rānei o kaitāwhai kē atu i te rori, pērā i waka kē atu, i te kaieke pahikara, i te waehīkoi ranei
- » ngā panonitanga ā-huarere, ā-rori anō hoki.

E haumarū ai te aro ki ngā mōreareatanga, me taunga koe ki te whakamahi i te mahere kaupare mōreareatanga, me te pūnaha whakahaere waka ka kōrerotia i tēnei wāhanga.

Te mahere kaupare mōreareatanga

Ka hautū ana, me rite tonu tō:

- » noho mataara ki ngā mōreareatanga ka pā pea ki a koe
- » matapae i te āhua e whanake ai pea te mōreareatanga, e raru ai anō hoki tō haumarutanga
- » whakatau me aha koe hei kaupare i te mōreareatanga
- » whakaū i tāu i whakatau ai mā te whai i te pūnaha whakahaere waka.

Hei tauira, mēnā he tamariki, e pātata ana te tākaro ki te taharori, ka oma atu pea rātou ki te aru i tētahi pāoro, ki te aru rānei i tamariki kē atu. Mā te whakamahi i te pūnaha whakahaere waka, kōwhiria te ara e tawhiti katoa ana i ngā tamariki, engari e ū tonu ai koe ki tō taha o te rori, tirohia tō whakaataata, whakamahia te whakatumu, ka whakapōturi ai i tō haere.

Te pūnaha whakahaere waka

He tukanga hautū waka tēnei e haumarua ana, e māmā ana anō hoki, hei āwhina i a koe kia haumarua ai tō aro ki ngā mōreareatanga. Māna koe e tau ai ki te wāhi tika i te rori, e tika ai te tere o tō haere, e tika anō ai te nihowhiti e whakamahia ana e koe.

Whakamahia tēnei pūnaha ka whakatata atu ana koe ki tētahi momo mōreareatanga.

- » **Te ara:** kōwhiringia tētahi ara e haumarua ana, e tika ana anō hoki e ai ki te ture.
- » **Ngā whakaataata:** kia rite tonu tō tiroiro i ngā whakaataata kia kite ai i te tūnga o ngā waka katoa i ō tahataha.
- » **Te tiro ā-mātenga:** tirohia ō whaitua huna i ngā wā katoa.
- » **Te tūtohu:** me tūtohu i ngā wā katoa mēnā e whai ana koe ki te panoni i tō tūranga i te rori.
- » **Te tumu:** whakamahia ngā whakatumu hei whakapōturi i tō haere.
- » **Te nihowhiti:** kōwhiria te nihowhiti e tika ana e ai anō ki te tere o te haere o tō waka.
- » **Te whakahohoro:** kia haumarua te whakahohoro kia wehe atu ai i te mōreareatanga.

Ngā mōreareatanga huhua

Me uua ka kitea noatia tētahi mōreareatanga i te wā kotahi ka hautū ana. I te nuinga o te wā, ka mate koe ki te aro ki ngā mōreareatanga huhua i te wā kotahi.

Nō reira, me mātau tonu koe ki ngā mōreareatanga katoa, engari me aronui ki te mōreareatanga e nui rawa atu ana te tūpono ka huri hei āhuatanga whakawhara e mate ai koe ki te aro tōtika atu.

Te tautohu i te mōreareatanga matua

Ko tā ēnei pikitia he whakaatu i ngā horopaki e kitea ana te huhua o ngā mōreareatanga i mua i te aroaro o te kaihautū o te waka kikorangi.

Kia mahara ake, ko te mōreareatanga matua, ko tērā e nui katoa ana te tūpono ka mate koe ki te aro tōtika atu, ka mahi whawhati tata ai.

Ko te mōreareatanga **A** te mea matua. Kua puta tonu atu te kaieke pahikara ki waho atu o te waka e tū ana, ka hou atu ai ki te ara o te waka kikorangi.

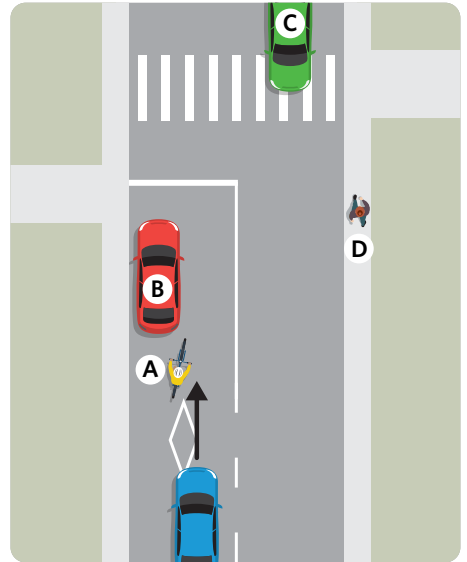

Ko te mōreareatanga **B** te mea matua. E haere whakamuri ana tēnei waka i tētahi tūnga waka, ā, kua hou tonu atu ki te ara o te waka kikorangi.

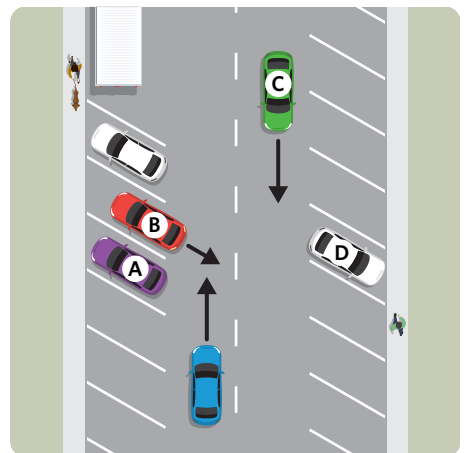

Ko te mōreareatanga **D** te mea matua. Kua whakawhiti tonu atu tēnei waka i te ara o te waka kikorangi.

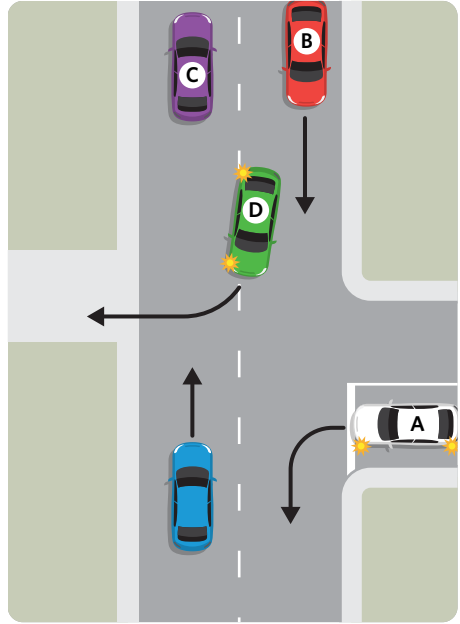

Ko te mōreareatanga **B** te mea matua. E aro kē ana te tamaiti ki te pakeke kei tērā atu taha o te rori. Kia mahara ake, ka ngana pea te tamaiti ki te whakawhiti noa i te rori, tē tiro tiro haere ai.

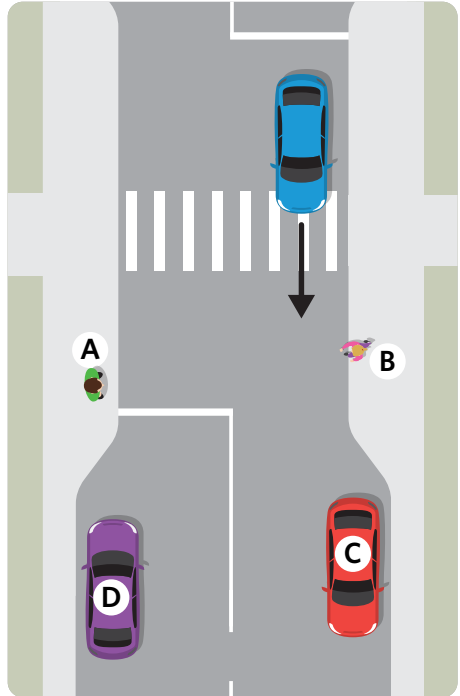

He kupu āwhina mō te hautū, kia haumaruru ai

Me whakaroa tō tirohanga

Ko tētahi o ngā mea e whai tikanga katoa ana e taea ana e koe kia haumaruru ake ai koe hei kaihautū, ko te aro ki tua rā anō i a koe e hautū ana, e wawe ai tō aro atu ki ngā āhuatanga e tūpono mōrearea ana.

Ki te wawe tō kite i tētahi tūpono mōreareatanga, ka nui ake te wā ki a koe ki te karo atu ina mate koe ki te pērā.

Kei aro noa ki te waka kei mua i a koe, i a koe e hautū ana, me tiro tiro kē i te rori kei mua i a koe, kia 12 hēkena, roa atu rānei te tawhiti i mua atu i tō waka – arā, ko te wāhi e tau atu ai koe ka hipa ana te 12 hēkena koe e hautū ana.

Hei wāhi ārahi i a koe, ina 50km/h te tere o te haere, ka 166 mita te kokenga i te 12 hēkena, ko tōna 2 paraka tāone rānei. Ina 100km/h te tere o te haere, ka 333 mita te kokenga i te 12 hēkena. Nō reira, ina 100km/h te tere o te haere, me ngana koe ki te titiro ki tua noa atu i a koe.

Kia tiro tiro haere ngā kanohi

He tini tonu ngā tāngata ka tiro whakamua noa, ka hautū ana. Me te aha, kāore rātou e kite ana i te whānuitanga o ngā nekenekheanga i te rori.

Āpiti atu ki te titiro whakamua, me whakamahi hoki ō whakaataata kia rite tonu tō tiro tiro ki ngā tahataha, ki muri anō hoki, e mātau ai koe ki ngā waka e karapoti nei i a koe. Mā te pēnei e āwhinatia ai koe kia kite i ngā tūpono mōreareatanga ana e whanake ana pea i ō tahataha, i muri rānei i a koe.

Mā te kōpiupiu haere i ō karu, me te aro ki ngā āhuatanga e puta ana i tō taiao hautū, e āwhina ai i a koe kia mataara tonu i ngā haerenga roa.



Kia aronuitia

Ko te momo inihua e iti katoa ana te utu, ko te whai wāhi wātea, huri noa i tō waka.

Ki te nui ake te wāhi wātea, ka haumaruru ake ko koe.

Whakaritea he taiwhakamaru

Me whakarite e koe tētahi taiwhakamaru huri noa i tō waka katoa mā te whakaū i tētahi tawhiti haumarū i waenga i a koe, i waka kē atu me ngā tūpono mōreareatanga.

Mā te pēnei e nui ake ai te wā me te wāhi ki a koutou ko kaitāwhai kē atu i te rori hei karo i ngā mōreareatanga.

- » Whakaritea tētahi taiwhakamaru i mua i a koe mā te ū ki tētahi tawhiti whaiwhai e haumarū ana. Whāia te tikanga 2-hēkena, te tikanga 4-hēkena rānei ina tika ana te pērā (whārangi 55-56).
- » Whakaritea tētahi taiwhakamaru i muri i a koe mā te ū ki tētahi tawhiti whaiwhai e haumarū ana i waenga i a koe me ngā waka e whai ana i a koe. Mēnā e pātata rawa ana tā tētahi waka whai i a koe, whakapōturihia tō haere, e neke ki te taha ka tuku ai i taua waka rā kia tohipa, ka haumarū ana tō pēnā.
- » Whakaritea tētahi taiwhakamaru ki ō tahataha mā te ū ki tētahi tawhiti e haumarū ai koe i ngā mōreareatanga i ō tahataha, pērā i ngā ara urunga, i ngā waka kua whakatūria, i ngā kaieke pahikara, i ngā tamariki rānei e tākaro ana ki te ara hīkoi.

Kia aro pū tonu

Ka māmā noa te pakihaha haere ka hautū ana koe. Ko ngā mea pēnei i te puoro, i te kōrerorero ki ngā pāhihi, i te tohipa i ngā whakaariari, me ngā whakatairanga i ngā rori, ka whakararu i tō aro ki te hautū me te rori.

Me ako koe ki te karo i ngā whakawai, ka aro kē ai ki te hautū, i a koe e hautū waka ana. Mēnā ka mate koe ki te tahuri atu i te rori, whāia ēnei tohutohu:

- » Me tiro ki mua noa atu, ki muri anō hoki i a koe mō te tūpono he mōreareatanga ka kitea. Kei huri tuarā ina kitea e koe ētahi tūpono mōreareatanga.
- » Kia maumahara, ki te titiro koe ki wāhi kē atu i te rori, kaua e kotiti.
- » Kia kaua e roa ake tō titiro ki wāhi kē atu i te rori, i tēnā e tino hiahiatia ana. Hei tauira, ka 90km/h ana te tere o te haere, ki te tiro koe ki wāhi kē atu i te rori mō te 2 hēkena, kua 50 mita kē te kokenga.

Tautohungia ngā ara pahiko

Mā te whai i ngā tohutohu o mua hei āwhina i a koe ki te karo i ngā tuinga waka e tūpono mōrearea ana. Heoi anō, arā tonu pea ētahi wā e haere ana koe i te ara o tuinga ihuwaka, o mōreareatanga kē atu rānei.

Nā tēnei, he mea pai kia tautohungia ngā ara pahiko e taea ana i ngā wā katoa, i a koe e hautū ana. Mā te pērā, ki te rongo koe i te mōreareatanga kei hua pea he tuinga waka, ka āhei tō aro tika tonu atu ki te karo atu.

Ko te nuinga o ngā ara pahiko kei tō taha mauī, nō reira me āta aro ki tērā kei te taha mauī o te rori, ka hautū ana koe. Me whakaaro ake koe:

- » He wāhi whānui rānei hei haeretanga māku?
- » Ka oti rānei i ahau te urungi atu i te rori, kia haumarū ai, ina mate ki te pēnā?

Mēnā karekau he ara pahiko e haumarū ana, whakapōturihia tō haere, ka whakaroa ai i tō tawhiti whaiwhai e taea ai e koe te whakatū wawe i tō waka ina whanake haere ai tētahi āhuetanga e hua ake ai he tuinga waka.

Te whai wāhi ki ngā akoranga hautū waka

Hei kaihautū, e kore e mutu tō ako. Me rite tonu tō kimi ara hei whakapakari i ō pūkenga hautū, kia haumarū ai.

Ko te haratau me te waiaro pai hei āwhina i a koe ki te whakapakari i ō pūkenga, engari, arā anō hoki ētahi akoranga hei āwhina i a koe kia haumarū ai tō hautū waka.

Mō ētahi mōhiohio e pā ana ki ngā akoranga hautū kaiaka i tō rohe, e toro ki tā mātou paetukutuku, ki nzta.govt.nz/advanced-driving-course

He kupu āwhina mō te aro ki ngā āhuatanga hautū ohotata

I ētahi wā, ahakoa to āta hautū, ka tūpono tonu pea koe ki tētahi āhuatanga ohotata. Me ako koe me pēhea te aro ki ngā āhuatanga ohotata ki te tūpono hua ake.

Te paheke

Kāore te waka e paheke mō te kore noa iho nei. I te nuinga o te wā, he mea hua ake i te:

- » kaha whakahohoro
- » kaha tumu
- » te panoni ohotata i te ahunga
- » horo rawa o te hautū i ngā rori mākū, i ngā rori pia-kore rānei.

Me rerekē te mahi whakatika i te ahunga o te waka mō ngā momo paheketanga rerekē. Me mōhio koe me aha ina tīmata ai te paheke haere o tō waka.

Hei whakamōhio: ko ngā aratohu e whai ake nei e hāngai noa ana ki ngā waka me ngā whakatumu māori, kua ko ērā e whai whakatumu ABS ana. Mēnā he whakatumu ABS ō tō waka, kua rawa e pato i ngā whakatumu i tētahi horopaki ohotata. Kia mārō tonu te pei i te whakatumu, ka urungi ai i te waka kia haumarū anō ai.

Te paheke 4-wīra

I te paheke 4-wīra, ka raka ngā wīra e whā ka mārō ana te tumu.

Ki te pēnei, ko tāu he:

- » āta pei i ngā whakatumu kia huri anō ai ngā wīra, kia rapa anō ai ki te rori.

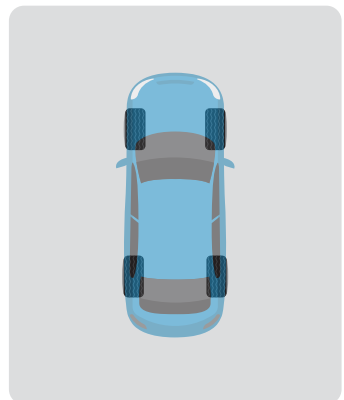

Te paheke wīra whakamua - te huri takarepa

I te paheke wīra whakamua, ka tōtika tonu te haere o te waka, tē whai ai i te ahunga o ō wīra.

I tēnei momo paheke, me kaua e tumu.

Ko tāu he:

- » pei i te whakatangatanga - mēnā e hautū ana i tētahi waka nihowhiti ā-ringa
- » tango mai i tō waewae i te whakahohoro
- » huri i te wīra urungi kia hāngai ai ki te ahunga o te waka
- » tuku i te whakatangatanga, hei te wā kua tau anō tō whakahaere i te waka.

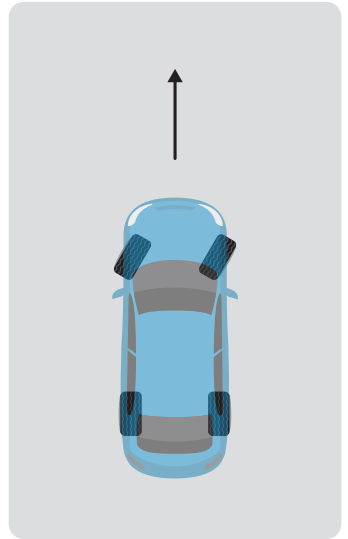

Te paheke wīra whakamuri - te huri tuwhene

I te paheke wīra whakamuri, ka kauhuri te hiku o te waka.

I tēnei momo paheke, me kaua e tumu.

Ko tāu he:

- » pei i te whakatangatanga - mēnā e hautū ana i tētahi waka nihowhiti ā-ringa
- » tango mai i tō waewae i te whakahohoro
- » huri i te wīra urungi kia hāngai ai ki te ahunga e paheke nei ngā wīra o muri
- » tuku i te whakatangatanga, hei te wā kua tau anō tō whakahaere i te waka.

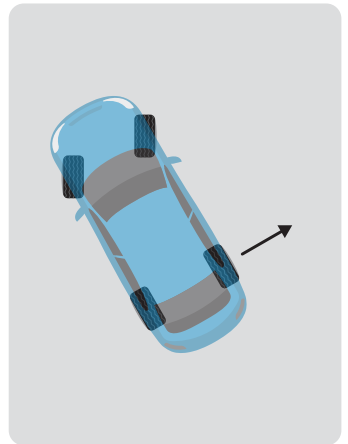

Ngā pahūtanga taea

Ka mōrearea pea ngā pahūtanga taea, inā koa mēnā e tere ana tō haere, i te mea mā reira pea e raru ai tō āheinga ki te whakahaere i tō waka.

I te nuinga o te wā, ka pahū ana ngā taea o mua, ka tōia te waka ki te taha kei reira rā te pahūtanga. I te nuinga o te wā, ka pahū ana ngā taea o muri, ka tīhataha kē te haere o te waka.

Ka taea pea tō karo i te huatanga mai o te pahūtanga ki te rite tonu tō tiroiro i ō taea. He mea nui kia tika te pēhanga hau i ō taea. Mēnā he hahae, he pupuhi rānei tō te taea, kua pūnguru katoa rānei, me whakahou.

Ki te pahū tētahi taea i a koe e hautū ana, me:

- » mārō tō pupuri ki te wīra urungi
- » āta tango mai tō wae i te whakahohoro
- » whai kia ū tonu tō waka ki tōna ara
- » me tūtohu, ka urungi ai i tō waka ki te taha o te rori ka oti ana i a koe te whakapōturi haere.

Te pakarutanga pūkaha

Ina pau noa te kaha o te pūkaha o tō waka i a koe e hautū ana, me ngana koe ki te urungi i te waka ki te taha o te rori, me te tere, te haumarua anō hoki o te pērā.

Me:

- » tūtohu, ka urungi ai i tō waka ki te taha o te rori
- » whakamahi te nihowhiti wātea - mā tēnei e tawhiti ake ai te kaunuku whakamua
- » whakakā ō rama mōreareatanga ka tū ana tō waka.

Mēnā he pūnaha urungi hiko tō tōu waka, me uaua ka urungi ka mate ana te pūkaha o te waka. Kei ohorere mēnā ka uaua ake te whakahaere i te waka. Puritia te wīra urungi kia ita, ka ngana ki te urungi tonu i te waka.

He whakahohoro kua mau

Ko tētahi urupare māori a te tokomaha kaihautū ka mau ana te whakahohoro, ko te whakaweto i te pūkaha. Ehara tēnei i te whakaaro pai, inā koa mēnā he pūnaha urungi hiko, tumu anō hoki ō tō waka, i te mea, mā te pēnei, ka tino uaua ake te urungi i te waka, kāore hoki e tino whai hua ngā whakatumu.

Me:

- » ngana koe ki te hiki i te whakahohoro ki ō matiwaē
- » whai kia noho tonu te waka ki te nihowhiti
- » tumu - ka whai kaha tonu ngā whakatumu ki te whakatū i te wā, ahakoa e rere tonu ana te pūkaha
- » urungi tonu te waka, ka kimi ai i tētahi wāhi e haumarua ai tō wehe i te rori.

He matapihi pākarukaru

Kāore i pērā rawa te kaha o te kitea o ngā matapihi kua pākarukaru katoa i enei rā, i te mea ko te uinga o ngā waka hou, kua whai matapihi karaihe haumaruru, arā, ka tawhā, engari anō te pākarukaru. Ka huri pea ngā hawa kōhatu hei tawhā, ā, i reira ngoikore ai te matapihi. Me mātua whakatika ngā hawa i mua i te huringa hei tawhā.

Mēnā e hautū ana koe i tētahi waka āhua tawhito, ā, ka pākarukaru tō matapihi, me:

- » urungi i tō waka, e titiro atu ana mā te matapihi i te taha, mēnā kāore e kite ana mā te matapihi pākarukaru. Mēnā i aro koe ki te rori mā te whai i te tikanga 2-hēkena, i tōna tikanga he autai tonu te pikitia o te rori kua mau ki te hirikapo, ā, mā tērā e āwhina i tō urungi i te waka
- » kaua e poka i te karaihe pākarukaru, mēnā ehara i te mea me pērā rawa. Ka motu pea tō ringa, ka mutu, ka puhia atu pea ngā wāhi karaihe ki roto i ō karu
- » wawe te neke ki te taha, ka whakatū ai i tō waka
- » meke atu te karaihe pākarukaru ki te hiki waka, ki tētahi taputapu kē atu rānei, ka tū ana tō waka. Mēnā karekau he taputapu e wātea ana ki a koe, tākaia tō ringa ki tētahi papanga pītongatonga, pērā i te poraka, i te tāora rānei, ka āta mekea atu ai te karaihe
- » āta hautū atu ki te kaiwhakatika matapihi e pātata katoa ana.

Te ahi waka

Mēnā e whakapae ana koe he ahi kei tō waka, me aro tōtika atu. Me:

- » tūtohu, ka neke ai ki te taha o te rori
- » wawe tonu tā koutou ko ngā pāhihi puta i te waka
- » whai kia tawhiti rawa ngā tāngata katoa i te waka, me ngana hoki ki te whakamōhio i ngā waka e ahu pēnā atu ana ki a koe
- » waea te ratonga patuahi.

Kaua e ngana ki te tīnei i te ahi, kei whakangā kē koe i ngā hau tāoke, tērā anō hoki te tūpono ka pahū te waka.

Te rū whenua

I tētahi rū whenua e pākaha ana, ka tino uaua pea te hautū inā hoki ka oreore pea, ka tīemiemi rānei te rori i raro i a koe.

Mēnā e whakapae ana koe e rū ana te whenua i a koe e hautū ana, me:

- » whakatū i tō waka ki te taha o te rori
- » noho tonu ki roto i tō waka kia mutu rā anō te oreore. Ko tō waka hei momo whakamarumarū mōu, hei kaupare i ngā mea e taka iho ana.

Whai muri i te rū whenua:

- » mēnā kua taka ētahi waea hiko ki runga i tō waka, me noho tonu ki tō waka kia tae rā anō ētahi atu ki te āwhina i a koe
- » ki te hautū tonu koe whai muri i te rū whenua, kia mataara ki ngā horonga whenua, ki ētahi atu pākarukarutanga rānei i te rori, ki ētahi atu taero rānei i te rori
- » whakakāngia te reo irirangi, ka whakarongo ai ki ngā kōrero mō ngā kapinga rori ka tūpono hua ake, mō ētahi atu mōhiohio anō hoki.

Te waka taupunga

He nui ngā rori takutai me ngā rori ākau i Aotearoa, ā, he wā ōna ka taupungahia.

Ko tō mōhio me aha ki te pā tēnei āhuetanga ki a koe, koia pea tō whakaora.

- » Mēnā e taea ana, e puta i te waka ka mānu tonu ana. I te nuinga o te wā, he mēneti ruarua noa iho, ka totohu ai.
- » Me puta mā te whakaheke i te matapihi. Nā te taumaha o te wai e pēhi ana i ngā kūaha, me uaua rawa ka tuwhera i te nuinga o te wā.
- » Ka taupunga ana, ka papī haere te wai ki roto i te waka. E puta mā ngā matapihi. Mēnā e kore e taea, me tatari kia kikī haere te waka, kia tata ai te taumata o te wai ki tō māhunga. Ka pērā ana, ka māmā ake te whakatuwhera i ngā kūaha i te mea ka tata ōrite te pēhanga wai i roto i te waka, ki tērā i waho atu.
- » I mua i te wehe i te waka, whakakāngia ngā rama e māmā ake ai tā ngā kairauora kite atu.
- » Whakaritea mai he mekameka tāngata ki ngā pāhihi, ka wehe ana koutou i te waka. Mā te pēnei, ka noho tahi koutou ki a koutou.

Ka rere whakarunga te panati

Ka taea pea tō karo i te rerenga whakarunga o te panati mā te:

- » maumahara ki te āta whakamau anō i te panati o tō waka, ka tuwhera ana
- » neke tonu atu ki te taha o te rori ina kitea e tāwariwari haere ana, e tangatanga haere ana rānei te panati o tō waka i a koe e hautū ana.

Ki te rere whakarunga te panati i a koe e hautū ana, me:

- » urungi tō waka, e tiro tiro ana i te āputa i raro i te kaurori o te panati, i te matapihi rānei i te taha o te waka
- » āta tumu, me tautohu, ka neke ai ki te taha mauī o te rori.

Te mūhoretanga whakatumu

Ki te raru ngā whakatumu o tō waka, kāore e kore he wheako whakawehi.

Ka taea pea tō karo i te huanga ake o tēnei āhuratanga mā te tiro tiro auau nei i ō tumu. Me wawe te whakahou i ngā aupuru whakatumu i ngā wā katoa, me whakakī hoki te puoto kūtere whakatumu i ngā wā e tika ana kia pērā.

Ki te raru ō whakatumu i a koe e hautū ana:

- » me whakaheke te nihowhiti – e hāngai ana anō hoki tēnei ki ngā waka nihowhiti aunoa – hei āwhina ki te whakapōturi i te waka
- » me mārō, me horo anō hoki te pato i ngā whakatumu hei whakapau i te raukaha e toe ana i te pūnaha tumu waipēhi
- » āta hīkina ake te whakatumu ā-ringa – kia kua e mārō rawa te pērā, kei raka ngā wīra o muri
- » whakatūpatohia ngā kaitāwhai kē atu i te rori mā te whakakā i ō rama ihuwaka me ō rama mōreareatanga, mā te whakatangi hoki i te hāona
- » kimihia tētahi ara pahiko, pēnei i tētahi wāhi whānui i te taha o te rori, he pātiki papatahi, he rori aupiki rānei
- » mēnā koe e haere ana i tētahi auheke, ā, e kotiti haere ana te waka, me ngana ki te pāpā atu ki tētahi mea i te taha o te rori, pērā i tētahi kaho haumarū, i tētahi parenga, i te taparori rānei.

Te pakarutanga rama ihuwaka

Me uaua ka pakaru ngā rama ihuwaka e rua i a koe e hautū ana, engari ka tūpono hua i ōna wā.

Ki te raru ō rama ihuwaka i a koe e hautū ana, me:

- » whakapōturi tō haere
- » āta wehe haere i te rori, ka tū ai ki tētahi wāhi haumaruru
- » whakakā ō rama mōreareatanga.

Te karo i te tuinga ihuwaka

Ākene pea ko te tuinga ihuwaka te momo tuinga mōrearea katoa ka tūpono whai wāhi atu ai koe. E pēnei ana i te mea, ka tuki ana ngā waka e rua, ihu ki te ihu, ka tāparatia pea te tōpana o te tuinga, tēnā i te tōpana ka hua ake ka tuki ana tētahi waka ki tētahi mea whakaroau.

Mēnā ko te āhua nei he tuinga ihuwaka e haere ake ana, arā tonu ētahi mea ka taea e koe hei karo pea i te tuinga, hei whakatāharahara rānei i tōna pākinotanga:

- » Me mārō te tumu. Ka whakapōturi ana, mō ia kiromita, ka heke te nui o te pākinotanga ki te hua ake he tuinga.
- » Me raparapa ō rama ihuwaka, me whakatangi hoki te hāona e aro pēnā atu ai tērā atu kaihautū.
- » Kimihia tētahi ara pahiko i tō taha mauī, ahakoa ka mate pea koe ki te wehe i te rori. He nui ake te tūpono, kāore e pērā rawa te kino o te tuinga e takahuri ai te waka, tēnā i te tuinga ihuwaka.
- » Kaua e perori ki tō taha matau. Kāore e kore ko te urupare a tērā atu kaihautū, ko te perori ki te taha mauī, me te aha, ka tūpono tūtuki kōrua ki a kōrua.

Mō ngā tepenga



Mō ngā tepenga

Ākona ngā tepenga me mātua mōhio koe, ka hautū waka ana – mō te paetere, mō te waipiro, me ōu anō tepenga hoki.

Ngā paetere

Ko te tere rawa o te haere tētahi o ngā kaikōhuru kino katoa i ō tātou rori. He tangata ka mate i ia tau i Aotearoa nei, i ngā tūkinga waka kua hua ake i te tere o te haere.

Kia mahara, ki te tere ake tō haere, ka nui ake te tūpono ka mate, ka kino rānei te wharanga ina tukia tō waka.

Ngā aratohu mō te tere e haumarua ana

E āhei ana tō haere i tētahi tere e pōturi ake ana, e ōrite ana rānei ki te paetere, mēnā:

- » e haumarua tonu ana te tere o tō haere e ai anō ki te nui o ngā waka – me whakapōturi tō haere mēnā kei tētahi rori koe e kapi ana i te waka, mēnā rānei he waehīkoi, he pahikara rānei i ō tahataha
- » e haumarua tonu ana te tere o tō haere e ai anō ki ngā āhuatanga i te rori – me whakapōturi tō haere mēnā e kōpiko ana, e torehapehape ana, e whāiti ana, e mākū ana, e tio ana rānei te rori
- » e haumarua tonu ana te tere o tō haere e ai anō ki te huarere – me whakapōturi tō haere mēnā e ua ana, e kaha ana te hau, e pūkōhu ana rānei
- » ka oti tonu tō whakatū ohotata nei i tō waka i muri i tērā e whāia ana e koe – ki te ohotata te tū o tētahi waka i mua i a koe, ā, ka tukia e koe, ko koe ka noho haepapa ā-ture nei
- » ka taea e koe tō waka te whakatū i tētahi haurua o te wāhanga wātea o te rori e kitea ana i mua i a koe, mēnā kei tētahi rori kāore ana rārangi wawaenga, ana ara rānei – hei tauira, ko tētahi rori whāiti i tuawhenua e tūpono tūtaki ai ngā waka, ihu ki te ihu
- » ka taea e koe te waka te whakatū i te wāhanga wātea o te rori e kitea ana i mua i a koe, mēnā kei tētahi rori whai rārangi wawaenga, whai ara rānei.

Kia aronuitia

Ka mana te huringa paetere ka tae ana ki te pou kei reira rā te tohu. I mua i te taenga atu ki te tohu paetere, me:

- » mātua whakapōturi tō haere, mēnā he paetere pōturi ake e tohungia ana
- » kaua e whakatere i tō haere kia tohipa rā anō koe i te tohu, mēnā he tere ake te paetere e tohungia ana.

Ngā kaihautū pōturi

Mēnā e pōturi ake ana tō haere i te paetere, ā, he waka e whai ana i a koe, me mātua:

- » ū koe ki te taha mauī rawa o te rori
- » neke ki te taha mauī, ka haumarua ana te pērā, e tohipa ai ngā waka e whai ana i a koe.

Kaua e whakatere i tō haere ngā wāhanga tōtika o te rori hei aukati i te tohipatia ōu e waka kē atu.

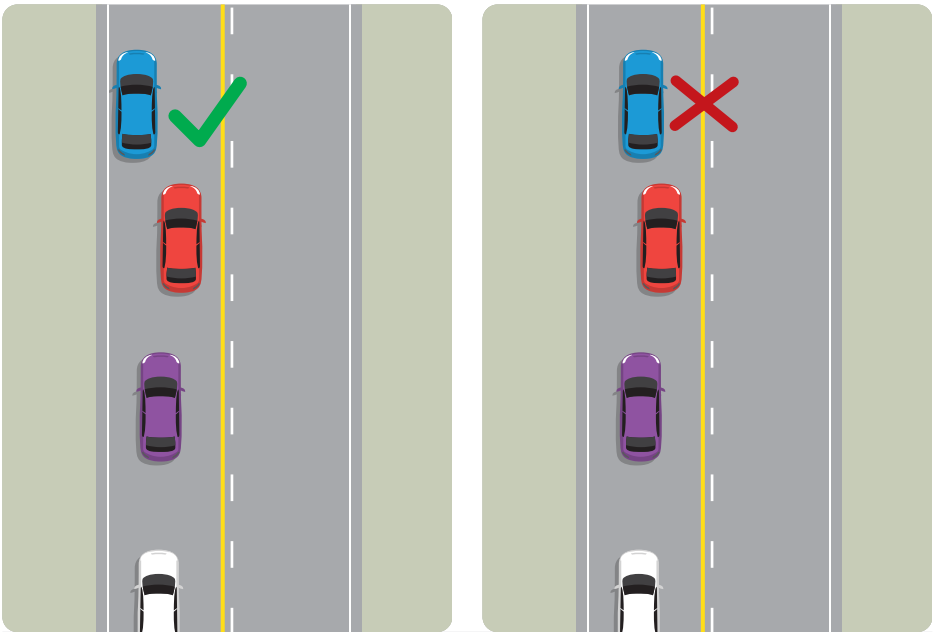

Ngā tohu paetere whakature

Ko te paetere, ko te tere mōrahi o te haere e whakaaetia ana ā-ture nei, ka hautū waka ana i te rori i ngā wā e pai tonu ana te āhua o te taiao hautū. Kitea ai ngā tohu e whakaatu ana i te paetere i te taha o te rori. I te nuinga o te wā, he tapa whereo tō ēnei tohu, e mea ana he tohu whakature.

E pai ana kia pōturi ake tō haere i te paetere e tohungia ana, engari me mātua whai whakaaro ki ngā waka kei muri i a koe.

Me mātua pōturi ake tō haere i te paetere, mēnā:

- » nā te āhua o te taiao hautū, ka mōrearea kē te paetere e tohungia ana, mēnā rānei
- » e hautū ana koe i tētahi momo waka, nā reira rā me pōturi ake tō haere, pērā i te waka taimaha.

Ko ētahi taurira o ngā tohu paetere.



Ko te tere mōrahi e whakaaetia ana ko te 50km/h



Ko te tere mōrahi e whakaaetia ana ko te 70km/h



E mana i konei ko te 30km/h hei paetere taupua

He mea whakatū ngā tohu paetere taupua i te nuinga o te wā mēnā e kōkiritia ana ētahi mahi i te rori tonu, i tētahi wāhi rānei e pātata ana ki te rori.

Te paetere i te rori tuwhera

Ko tā ēnei tohu e rua, ko te 100km/h te tere mōrahi e whakaaetia ana.

Ka whai ana i waka kē atu, kia mahara, he pōturi ake te paetere e whakaaetia ana mō ētahi waka, nō reira ka mate pea koe ki te whakahāngai i te tere o tō haere.

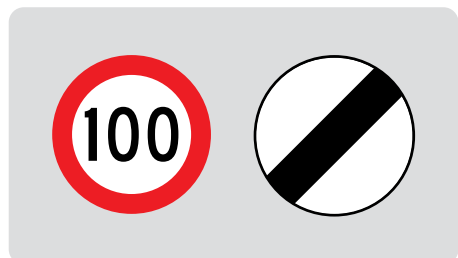

Ko ngā waka e rārangi mai ana i te ripanga i raro iho nei, he pōturi ake te paetere mōrahi e whakaaetia ana mō rātou, i tērā mō ngā waka taimāmā.

Ngā momo waka	Ko te paetere mōrahi i te rori tuwhera
Ko te waka taimaha (arā, ko te waka, kei koni atu i te 3500kg te taumaha tapeke), me te waka taimaha e tō tauaru ana	90km/h
Ko te waka taimāmā e tō tauaru ana	90km/h
Ko te pahi kura, kei koni atu i te 2000kg te taumaha tapeke e whakaaetia ana	80km/h
Ko te waka e whakamahi ana i tētahi taura tō, i tētahi momo hono pīngore rānei hei tō i tētahi waka, hāunga i te motupaika, i te waka tāwhai rānei	50km/h
Ko te waka taimaha, kāore ōna pūniko, kāore rānei he momo hono kē atu i waenga i ngā wīra rori me te hanga o te waka	45km/h
Ko te waka e tō ana i tētahi motupaika, i tētahi waka tāwhai rānei kua hauā	30km/h

Ngā paetere kura

Whakakāngia ai ngā tohu paetere kura e whakamahia ana i mua, whai muri anō hoki i te kura, i wā kē atu anō hoki e rere ana he kaupapa i te kura.

Ko te tohu i te taha mauī e tohu ana i te wāhi e tīmata ai te paetere kura. Mēnā e kitea ana te 30, te 40 km/h rānei, ka raparapa te porowhita whero, hei tohu i te tere mōrahi ka tohipa ana i te kura, kia mutu rā anō te paetere kura.

Ko te tohu i te taha matau ka kitea i te taha o te rori.

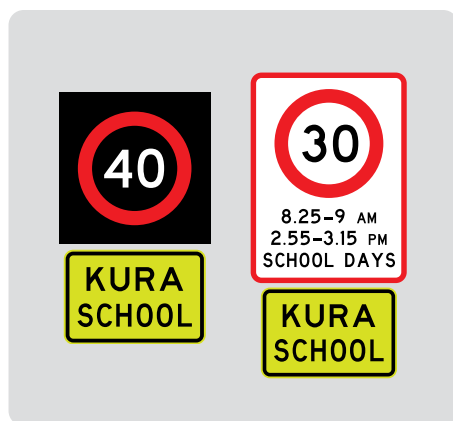

Ngā tohu kē atu e mea ana me mātua whakahāngai te tere o tō haere

He tohu mō te tuinga, mō te ahi, mō āhuatanga ohotata kē atu rānei

Ko tā ēnei tohu, e whakatata atu ana koe ki tētahi tuinga, ki tētahi waka kua raru, ki tētahi ahi, ki tētahi āhuatanga ohotata kē atu rānei. Me whakapōturi tō haere, kia 20km/h, kia pōturi ake rānei, kia tohipa rā anō koe i te wāhi o te āhuatanga ohotata.

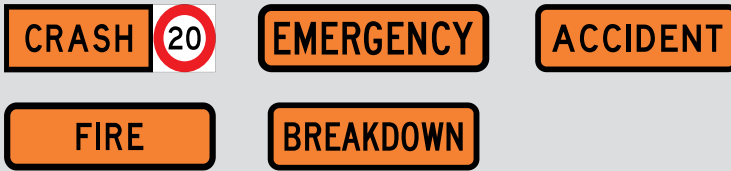

Kia aronuitia

Ki te nui ake i te 40km/h te tere tuwhene e haere ana tētahi kaihautū i tētahi paetere pūmau, ka aunoa te whakakorehia o te raihana hautū mō te 28 rā. Ki te nui ake i te 50km/h te tere tuwhene e haere ana tētahi kaihautū i tētahi paetere taupua, ka aunoa te whakakorehia o te raihana hautū mō te 28 rā.

Ngā tohu pahi kura

Kitea ai ēnei tohu i ngā pahi kura. Mēnā kua tū tētahi pahi kura, me mātua whakapōturi tō haere, kia 20km/h, kia pōturi ake rānei. E mana ana tēnei tikanga mēnā:

- » e raparapa ana ngā rama i te tohu pahi kura,
- » kua tū rānei te pahi, e kake atu ai, e tukuna atu ai rānei ngā tamariki kura, ahakoa kāore pea ngā rama e raparapa ana.



SCHOOL BUS

SCHOOL

Ahakoa tō ahunga, me mātua pōturi ake tō haere i te 20km/h, kia hipa noa atu koe i te pahi.

Ngā tohu whakamataara ki te kōpiko

Hei whakamataara ēnei tohu i a koe e whakatata atu ana koe ki tētahi kōpiko, ki tētahi hurihanga koi rānei i te rori. Ko te nama e tūtohu ana i tētahi tere e haumaruru ana, e hāneanea ana anō hoki ka haere ana i te kōpiko – i tēnei tauira, ko te tere e tūtohungia ana mēnā e pai ana te taiao hautū, ko te 35km/h. Ko ngā pere e tohu ana i te ahunga o te kōpiko.



Ngā tohu paetere whitiwhiti

Whakamahia ai ngā tohu paetere whitiwhiti hei āwhina i te taha ki ngā rori kūkā, ā, me whakahāngai te tere o tō haere ki tērā e tohua ana.



Ngā tepenga mō te waipiro me te pūroi

Ka nui pea te pāngia o tō āhei ki te hautū waka e te waipiro me te pūroi, tae atu anō hoki ki ētahi pūroi ka tukuna e te rata ki a koe. Ka whakapōturi pea i ō urupare, waihoki, ka raru pea ko ō tairongo.

Ka tūpono mate, ka kino rānei te wharanga ōu, o tangata kē atu rānei, mēnā koe ka kai waipiro, ka kai pūroi rānei, ka hautū waka ai.

Ngā tepenga waipiro ā-ture, ka hautū ana

Ko tā te ture, me kua rawa koe e hautū mēnā he nui ake te waipiro i ō toto, i tō hā rānei, tērā i ngā tepenga kua tohua e ai anō ki te pakeke o te tangata.

E tamariki iho ana i te 20 tau

Mēnā e tamariki iho ana koe i te 20 tau, ko te tepenga, ko te waipiro kore. Nō reira, ki te hautū koe whai muri i te inu, ahakoa pea kotahi noa iho te inu i pau i a koe, ka hāmenehia pea koe mō te hautū-inu.

- » Mēnā ko te nui o te waipiro i tō hā e iti iho ana i te 150 karamumiriona i te rita, e iti iho ana rānei i te 30 karamumano i ia 100 ritamano o te toto, ka whainahia pea koe, ka whiua hoki pea ki ngā piro whakawhiu e 50.
- » Mēnā he nui ake te waipiro i tō tinana, ka whakakorehia pea tō āhei ki te hautū, ka whiua koe ki ngā piro whakawhiu e 50, ā, ka whainahia koe, ka mauheretia rānei.

E rua tekau tau, neke atu rānei te pakeke

Me kua koe e hautū waka mēnā kei koni atu i te 250 karamumiriona te nui o te waipiro i ia rita o tō hā, kei koni atu rānei i te 50 karamumano te nui o te waipiro i ia 100 ritamano o te toto.

- » Mēnā ko te nui o te waipiro kei tō tinana kei waenganui i te 251 me te 400 karamumiriona i ia rita o te hā, kei waenganui rānei i te 51 me te 80 karamumano i ia 100 ritamano o te toto, ka whainahia pea koe, ka whiua hoki pea ki ngā piro whakawhiu e 50.
- » Mēnā he nui atu i tēnā te nui o te waipiro i tō tinana, ka whakakorehia pea tō āhei ki te hautū, ka whainahia hoki koe, ka mauheretia rānei.

Me uua ka mōhio e hia rawa ngā inu waipiro e taea ana e koe i mua i tō eke ki ēnei tepenga. Kei te āhua tonu o ētahi mea maha, tae atu ki:

- » tō ia

» tō rahi

» te nui o te kai kua kainga e koe.

I te mea, me iti noa te waipiro, ka pāngia tonuhia pea tō hautū waka, ko te tohutohu pai katoa e mea ana: ki te inu waipiro koe, kua e hautū waka.

Te pūroi me te hautū waka

Ko tā te ture anō hoki, me kua rawa koe e hautū mēnā kua kainga e koe tētahi momo pūroi ka whakaaweawe pea i tō āhei ki te hautū waka. Mēnā ka tūhōngia he pūroi e tō rata, me pātai rawa mēnā rānei ka pāngia te āhua o tō hautū waka.

Te whakamātau mō te waipiro me te pūroi

Ka āhei tā te pirihihana whakatū, whakamātau anō hoki i a koe mō te waipiro me te pūroi, ahakoa āhea. Ka āhei tā te pirihihana whakamahi i ēnei whakamātautanga i raro nei, kia mōhio ai mēnā rānei koe i te inu waipiro, i te kai pūroi rānei. I te tau 2023 tīmata ai ngā whakamātautanga matapōkere i te taha o te rori mō te hautū waka i raro i te awenga pūroi.

Te whakamātautanga hāngū mō te hā

Ka tonoa koe e te pirihihana kia kōrero ki tētahi taputapu ā-ringa ka meatia ki mua i tō waha. Ka whakaatu atu te taputapu nei mēnā koe i inu waipiro inakua nei. Ina rangona he waipiro, ko te whakamātautanga matawai mō te hā ka whai atu.

Te whakamātautanga matawai mō te hā

Ka hoatu e te pirihihana tētahi taputapu hiko iti ki a koe, ka tono ai i a koe kia pupuhi atu ki roto. Mēnā he nui rawa te waipiro ka rangona, ka tonoa koe kia mahi i te whakamātautanga taunaki mō te hā, i te whakamātautanga toto rānei.

Te whakamātautanga taunaki mō te hā

He taputapu hiko tēnei, ka pūhia e koe, ā, ko tāna he whakaputa i tētahi mātautanga ka āhei te whakamahi ki te kōti hei taunakitanga mō te kukūtanga o te hā me te waipiro.

Te whakamātautanga toto

Ina whakamātauria ō toto, ka tangohia atu e tētahi rata, e tētahi atu tangata rānei kua whakaaetia, tētahi tīpakohanga nō ō toto kia whakamātauria ai mō te waipiro, mō te pūroi rānei.

Te whakamātau waimaerotanga e whakature ana

E kapi ana i tēnei ko te whakamātau i ngā karu, i te hīkoi me te huringa, me te tū i te wae kotahi.

Ki te hinga koe, ka aukatingia pea tō āhei ki te hautū, ka mate hoki pea ki te whai whakamātautanga toto.

He mōhiohio anō hei tiro tiro māu mō ngā hara me ngā whiunga ki nzta.govt.nz/offences-and-penalties

Te ruha kaihautū

He tini ngā tukinga aituā i hua ake i tā te tangata hautū, ahakoa te ngenge. Ina rongo ai koe i te ngenge, kua e hautū. Kei noho ko tō ora, ko te ora rānei o tangata kē atu te papa.

Arohia ngā tohu whakamataara

Ko ngā tohu o te ruha ko:

- » te uaua o te aro, o te whakatuwhera i ngā karu, o te hī ake rānei i te mähunga
- » te muhukai, ko te rere haere o ngā whakaaro, ko te wareware rānei
- » te rite tonu o te hītakotako, o te mukua rānei o ngā karu
- » te whātino atu i tō ara, ko te arutata, ko te korenga rānei e kite i ngā tohu, i ngā putanga rānei
- » te rongo i te pītakatata me te āritarita.

He kupu āwhina hei kaupare i te ruha kaihautū

- » Kia au te moe i te pō i mua i te hautū, ko te painga atu kia 8 hāora te roa.
- » Me karo te hautū i ngā hāora e moe kē ana koe i te nuinga o te wā.
- » Mēnā he rite tonu tō hāmoemoe i waenga pū i te ahiahi, me karo te hautū i aua hāora.

- » Me whakaū, i muri i te moe, kua oho pai koe i mua i tō hautū.
- » Kaua e inu waipiro, ahakoa pea te iti. Ka kino kē atu te ruha.
- » Ka roa ana te haerenga, whakaurua atu he wā whakatā ki tō mahere haerenga.
- » Mēnā e taea ana, me whai hoa hautū.
- » Me timotimo i ngā kai ngāwari, i ngā kai mata hoki. Ka ngenge pea koe i te kai i ngā kai hinuhinu, i ngā kai hukahuka, i ērā rānei e kī ana i te warowaihā.

Me tū kia piki anō ai te kaha, ka hautū anō ai

I ngā haerenga roa, me whakatā i ia 2 hāora, i ia 100 kiromita rānei.

Ina rongu koe i te matemoe, i tētahi rānei o ngā tohu whakamataara:

- » kaua e hautū tonu - whakatūria tō waka ki tētahi wāhi haumarū, e tawhiti ana i te rori
- » me punua moe mō te 15-20 mēneti ki te tūru pāhihi. Me whai kia kaua e roa ake i te 40 mēneti koe e moe ana, kei rongu koe i te kaumingomīngō, i te pōrauraha rānei, ka oho ana - ka kīia tēnei ko te tūrūruhi moe
- » me tatari mō te 10 mēneti, me roa ake rānei, i mua i tō hoki ki te hautū, e mōhio ai kua oho pai koe.

Ka ū mārika ana te ruha, ahakoa te kaha o te niwha, e kore koe e oho tonu. Kotahi noa iho te whakautu, arā, ko te moe, ā, me tū koe ki te punua moe, me whai āwhina rānei e tau pai ai koe ki te kāinga. Ki te rongu tonu koe i te matemoe, kaua e hautū. Kimihia tētahi wāhi e roa ake ai tō moe, e pai ai rānei tō noho atu mō te pō.



**Ki te nui ake ngā whetū,
ka haumaru ake te waka**



E kitea ai ngā tohu o te wā mō te
haumarutanga waka me te whakaute taiao:

 e toro ki rightcar.govt.nz

Mō ngā haepapa o te kaihautū



Mō ngā haepapa o te kaihautū

He tini ngā haepapa o te kaihautū waka. Ko ētahi e hāngai ana ki te whai i tōu anō motokā, ā, ko ētahi atu, he haepapa nō ngā kaihautū katoa.

Ngā haepapa o te tangata rēhita

Mēnā ko tō ingoa kua tuhia ki te puka rēhita o tētahi waka, nōu te haepapa kia ea i te waka ngā herenga katoa.

Te rēhita

Me rēhita, me whai tohu rēhita hoki ngā waka katoa ka hautūngia ki ngā rori – e mōhiotia whānuitia ana ko ngā tohu tau. Me mārama te kitea atu i tō waka.

E toro ki nzta.govt.nz/vehicle-registration mō ētahi mōhiotio anō.

Te whakamana pakari waka (WoF), me te tiwhikete pakari waka (CoF)

Ko ngā waka katoa i ō tātou rori me whai i te whakamana pakari waka (WoF), i te tiwhikete pakari waka (CoF) rānei e mana tonu ana. Tirohia te whārangi 150 mō ētahi mōhiotio anō.

Te raihana waka - ka kīia ko te 'rego'

He wā ōna ka pōhēhē ētahi ko te raihana waka me te rēhita, e rua e rua. Engari kē ia, ko te raihana waka, ko te utua o tētahi nama e whakaaetia ai te whakamahia o tētahi waka i te rori. Ko ngā waka katoa ka haere i te rori, me auau te whakaraihana, me whakaatu hoki tētahi tohu raihana waka e mana tonu ana i te matapihi o mua.

E toro ki nzta.govt.nz/vehicle-licensing-rego mō ētahi mōhiotio anō.

Te utu whakamahi rori (RUC)

Ko te waka taimāmā, arā ko ērā he 3500kg iti iho rānei te taumaha noa, me whakaatu tētahi raihana RUC e mana tonu ana mēnā he waka ka kai i tētahi momo kora i tua atu i te kōhinu, i te LPG, i te CNG rānei.

Ko te waka taimaha – ko ērā kei koni atu i te 3500kg te taumaha noa – me whakaatu tētahi raihana RUC e mana tonu ana, ahakoa te momo kora ka kainga e te waka.

E toro ki nzta.govt.nz/ruc mō ētahi mōhiohio anō.

Te hoko mai, te hoko atu rānei i tētahi waka

Hei tā te ture, me mātua whakamōhio a Waka Kotahi ka hoko mai ana koe, ka hoko atu ana rānei i tētahi waka. Ko te ipurangi te ara pai katoa e tutuki ai tēnei mahi.

E toro ki nzta.govt.nz/buying-and-selling mō ētahi mōhiohio anō.

Te hautū matatika

Ko te hautū matatika, ko te hautū me te whakaaro nui ki te haumarutanga, ki te whakaute hoki i ngā kaitāwhai katoa i te rori.

Ngā haepapa kaihautū e whai tikanga ana

Te whakahaere i te waka

Me kua koe e hautū i tētahi waka, mēnā nā tōna āhua, nā te āhua rānei o tō hautū, ka:

- » whara tētahi tangata, tētahi kararehe rānei
- » whakahōhāngia tētahi tangata
- » tūkinohia tētahi rawa
- » whakawarea te kaihautū.

He waka, he utanga mōrearea rānei

Me kua koe e hautū i tētahi waka mōrearea, i tētahi waka rānei e mōrearea ana ana utanga, mēnā:

- » kāore e herea ana kia ita
- » ka taka iho pea i te waka
- » e tautō ana i te papa.

Te noho whakawhara i te waka

Me kua rawa koe e haere mā runga i tētahi waka, ahakoa i roto, i runga rānei, mēnā mā te pērā ka tūpono whara tētahi. Mēnā ko koe te kaihautū, me kua rawa koe e tuku kia whakawhara tā te pāhihi noho i roto, i runga rānei i te waka.

Te kawē i te pāhihi, i te utanga rānei

He mōrearea te pupuri, te whakanoho rānei i te pūhera, i te tangata, i te kararehe rānei ki runga i a koe i a koe e hautū ana. Meatia atu ngā pūhera ki

tētahi wāhi e ngita ai te noho, pērā i te pūtu o te waka. Mēnā tē taea, meatia atu ki tētahi wāhi i roto tonu i te waka, e kore nei tētahi e whara, ki te tū ohotata mai te waka.

Te tamariki me te mōkai

Ka hoihoi pea, ka hia āwhina rānei te tamariki me te mōkai i a koe e hautū ana. Ina mate koe ki te aro ki ngā hiahia o te tamariki, o te mōkai rānei, neke ki te taha o te rori, ka whakatū ai i tō waka i te tuatahi.

Ngā tūrama

Me kua rawa te kaihautū, te pāhihi rānei, e whakamahi i ētahi taputapu tūrama waka, e kōreko ai, e pōrauraha ai, e whakawarea ai rānei ngā kaitāwhai kē atu i te rori.

Ngā waka e hoihoi ana, e kaurukiruki ana rānei

Me kua rawa koe e hautū i te waka:

- » e tino hoihoi ana a roto, a waho rānei o te waka, nā:
 - › te āhua o te hautūngia o te waka
 - › te āhua o te waka
 - › tētahi mea kē atu – pērā i te reo irirangi o te waka
- » ko tana oro ka tūpono whakahōhā i te tangata
- » ka whakaputa auahi mō te 10 hēkena, roa atu rānei.

Me whai koe kia pai te hanga o te pūnaha whakaputa hau kino, me te pūkaha o tō waka. Mā te pēnei e kore ngā hau kino me ngā oro turituri rawa e hou atu ki te waka.

He hara hautū te hautū kia raru ai te rapa o ngā wīra o te waka, kia tāhurihuri haere ai i te mata o te rori, ka whakaputa oro mō te kore noa iho, ka paoa rānei.

Te whakatangi i te hāona

Me whakamahi noa hei whakamataara i ngā waka, mēnā e tika ana. Me kua te hāona e whakapāoro i te oro kāore nei ōna tino tikanga, e turituri rawa ana rānei, e tikākā ana rānei, e tiorooro ana rānei.

Te whakatuwhera me te kati i ngā kūaha

Me kua rawa koe e whakatuwhera, e kati rānei i te kūaha o te waka, mēnā mā te pērā ka tūpono:

- » hua ake he mōreareatanga ki tētahi atu kaitāwhai i te rori – tae atu ki te waehikoī, ki te kaieke pahikara, ki ētahi atu rānei e haere ana i te ara hikoī
- » tūkinō i tētahi atu tangata.

Te puoro

Kaua e pērā rawa te hoihoi o te puoro ka whakatangihia i tō waka, e kore nei koe e rongō:

- » i te oro o tō waka
- » i ngā tangi ohotata
- » i ngā pere whakatūpato, i ngā tereina rānei, ka whakatata atu ana koe ki tētahi whakawhitinga ara tereina.

Te aupiki, te auheke rānei o te haere

I ngā rori e tūpoupou ana, e whāiti ana anō hoki, ka māmā ake te tautuku a te waka e auheke haere ana, ki ērā e aupiki haere ana.

He raupapa tangihanga

Mēnā koe e hautū ana i tētahi raupapa tangihanga, kimohia ngā rama o mua e mōhio ai ngā kaihautū kē atu, e hono ana koe ki te raupapa tangihanga.

Te kararehe i te rori

He rite tonu tā te kaimahi pāmu whakamahi i ngā rori tuawhenua e pai ai te neke i ngā kararehe i tētahi pātiki, ki tētahi atu. Mēnā he kararehe kei te rori:

- » me whakapōturi tō haere, me neke rānei ki te taha o te rori
- » kaua e whakatangi i tō hāona, e whakaputa rānei i tētahi oro e tūpono wehi ai te kararehe
- » whāia ngā tohutohu ka tukuna pea e te kaimahi pāmu ki a koe.

Te karaihe pākarukaru, me ngā momo para rerekē i te rori

E noho haepapa ana koe ki te whakawātea atu i ngā mea e rārangi iho nei i te rori, ki te taka atu, ki te puta rānei i tō waka, ka tau iho ai ki te rori:

- » Te matū māniania.
- » Te matū werowero, te matū mōrearea rānei.
- » Te karaihe.

» Ko ngā momo matū kē atu, nā runga i tōna rahi, i tōna āhua rānei, ka noho pea hei mōreareatanga ki te kaitāwhai i te rori.

Mēnā ka taea e koe te whakawātea atu te rori, ā, ka horo, ka haumarū tonu, me mātua pērā koe, me whakarite rānei kia pērātia e tētahi atu.

Mēnā kāore e taea e koe te whakawātea atu te rori, kia horo, kia haumarū anō hoki, me whakatūpato koe i te hunga tūmatawhānui, me wawe rānei te whakamōhio atu i te pirihihana.

Mēna kāore e taea e koe te whakawātea atu, whakatūpatohia te hunga tūmatawhānui, whakamōhio atu rānei te pirihihana, kātahi ka noho haepapa ko te tangata ka whakawātea atu i te waka ki te whakatutuki i ēnei mea.

Ngā pū

Me kua rawa koe e hari haere i tētahi pū i tō waka mēnā kāore o raihana pū. Me kua rawa koe e hari haere i tētahi pū kua purua ki te kariri, i tō waka. Nō reira, me kua rawa koe e hari haere i te matā i te pakohu, i te kopa matā rānei o te pū.

Ngā wira taupua

He wira taupua tō ētahi waka hei wira tuwhene. He iti iho te wira taupua i ngā wira kē atu o te waka, e iti iho ai te wāhi hei tiaki i te wira.

Ko ngā wira taupua, me whakamahi anake i ngā wā ohotata, ā, ehara i te mea i hangaia mai hei wira mō ngā haerenga roa. Ki te haukore tētahi taea, ā, ka whakakapia tētahi wira ki te wira taupua, me whakamahi noa koe e tae tōtika atu ai koe ki te kāinga, ki tētahi wāhi rānei e whakatikaina ai, e whakahoungia ai rānei te taea haukore.

E tinga ana, ka rerekē te āhua o te waka i te rori ka whakamahia ana he wira taupua. Kia āta taraiwa, kia kua hoki e tere ake i te 80km/h. Mēnā he whakapiri tō te wira taupua e tohu ana i tētahi terenga e pōturi ake ana, me whai kē ko tērā.

Me mātua whai pānui haumarū te wira taupua e tohu ana he mea taupua noa te taea, ko te aha te tere mōrahi mō te taea, ko te aha hoki te pēhanga tika. Me mātua pānui, me mātua ū anō hoki koe i ngā tohutohu.

Kia mōhio mai: me whakaū koe e tika ana te pēhanga o te wira taupua. He nui noa atu te pēhanga, tēna i te pēhanga taea māori.

Ngā waea pūkoro

I a koe e hautū ana, kāore e āhei tō whakamahi i te waea pūkoro ka puritia ki te ringa, hei tuhi, hei tuku, hei pānui rānei i te kuputuhi, hei waea atu, hei whakautu rānei i te waea, hei toro rānei ki te ipurangi. E kapi ana i tēnei ko te noho noa i te waka e tū ana i te rori, pērā i te tū ki ngā rama pūtahi.

Heoi anō, e āhei ana tō whakamahi i tō waea ka hautū ana mēnā kua ita te noho i tētahi purihanga e piri ana ki te waka, ā, e kāore e kaha ana, ka mutu, e poto noa ana te whakamahia ōna.

E āhei ana anō hoki tō whakamahi i te waea pūkoro, ka hautū ana, hei waea atu ki 111, ki *555 rānei mēnā e mōrearea ana, mēnā rānei kāore e taea e koe te neke ki te taha, ka whakatū ai i tō waka ki tētahi wāhi haumaruru i te taha o te rori, ki reira waea atu ai.

Ngā whakawai i te kaihautū

Ko ngā mea katoa ka tō atu i tō aronga i te rori, he tūpono mōreareatanga. Me karo, me whai rānei e koe kia iti iho ai ēnei momo whakawai i a koe e hautū ana:

- » te tiro tiro ki ngā mea i te taha o te rori, ki ngā whakaariari rānei
- » te kōrero i tētahi waea pūkoro purikore
- » te kōrero ki ngā pāhihi
- » te tamariki turituri
- » te mōkai
- » te kai
- » te kā i te hikareti – tae atu ki te hikoreti, ki te momirehu rānei
- » te panoni i ngā whakahaere reo irirangi, paemahana rānei
- » te muhukai
- » te nenge
- » te mātai mahere
- » ngā taputapu e nekeneke haere ana i te waka
- » ngā taputapu hiko
- » te toro haere ki ngā mea i te pouaka karapu
- » te whakapaipai i te mata whakaroto o te matapihi o mua.

Ngā hāora mahi me ngā here mō te puka rārangi mahi

Mēnā koe e hautū ana i tētahi waka harihari ngaio, pērā i te tēkehi, i te Uber, i te taraka rānei, ka hāngai ki a koe ko ētahi herenga mō te roa o te wā e āhei ana tō hautu, me te nui o te wā whakatā me mātua ea i a koe. Ka mate hoki pea koe ki te whakakī i tētahi puka e rārangi mai ana ko ō hāora mahi.

E toro ki nzta.govt.nz/work-time-and-logbook mō ētahi mōhiohio anō.

Te tātua nōhanga me te whakaita tamariki

Ko tā te tātua nōhanga me te whakaita tamariki he whakahaumarū i te tangata mā te whakaita i a rātou ki ō rātou tūru ka tuki ana te waka, ka ohotata rānei te tū a te waka. Ki te kore koe e mau tātua nōhanga, ā, ka whai wāhi atu ki tētahi tuinga waka, ka whiua pea koe i tō waka. Kia maumahara ake i ngā wā katoa, whakamaua tō tātua i mua i te taraiwa atu.

Te whakaita tamariki

E tamariki iho ana i te 7 tau

Me tika te whakaitahia o te tamariki e nohinohi ake ana i te 7 tau ki tētahi whakaita tamariki kua whakamanahia. Heoi anō, mēnā e haere ana te tamaiti i tētahi tēkehi kāore nei ana whakaita tamariki kua whakamanahia, me noho te tamaiti ki te tūru o muri.

E 7 tau te pakeke

Me noho ngā tamariki e 7 tau te pakeke ki tētahi whakaita tamariki, mēnā e wātea ana tētahi.

Mēnā kāore tētahi e wātea, me whakaita tonu te tamaiti mā te whakamahi i tētahi whakaita tamariki, i tētahi tātua nōhanga rānei e wātea ana, ahakoa kāore pea taua whakaita tamariki, taua tātua nōhanga rānei i whakamanahia.

E toro ki [nzta.govt.nz/seatbelts](https://www.nzta.govt.nz/seatbelts) mō ētahi mōhiohio anō.

Te mau tātua nōhanga

Ko te nuinga o ngā tātua nōhanga e taea ana te hautō mai anō. Nō reira, ka aunoa te whakamārōro kia tika ai te roa ka whakamaua ana, ā, ka raka noa mēnā ka ohotata te tū a te waka.

Mēnā he tātua hautō-kore tō tō waka, me whakatika koe i tana roa i mua i te whakamau. I tōna tikanga, he wāhi iti noa e wātea ana e ō ai tō papanui ki waenga i te tātua me tō poho.

Kaua rawa e whakaita ngātahi i te pakeke me te tamariki ki te tātua nōhanga kotahi.

Te noho haepapa

E noho haepapa ana koe, hei kaihautū, ki te whakaū e noho ana te pāhihi i raro i te 15 tau i tētahi whakaita tamariki, i tētahi tātua nōhanga rānei kua whakamanahia.

Me tika te mau i te tātua nōhanga, me ita hoki te noho i te waka e haere ana i te rori.

Nō ngā pāhihi 15 tau neke atu rānei te pakeke te haepapa kia tika tā rātou whakamau i te tātua nōhanga, ka mutu, kia ita tonu te noho i te waka e haere ana i te rori.

Kāore e noho haepapa ana te kaihautū pahi i te waka e whai ana i te tātua nōhanga pāhihi ki te whakaū e mau tātua ana te pāhihi, hāunga i te pāhihi e tamariki iho ana i te 15 tau, e noho ana i te tūru o mua, i kō i te kaihautū.

Ngā motuhaketanga

Kāore koe e mate ki te mau tātua nōhanga mēnā:

- » he tiwhikete rata tāu e mana tonu ana e mea ana, nā te take hauora e kore nei koe e mate ki te mau tātua
- » e haere whakamuri ana tō waka, ā, me uaua koe ka kite i a koe e mau tātua ana.

Te mūhoretanga waka

Mēnā ka mūhore tō waka:

- » me tūtohu, ka urungi ai i tō waka ki tētahi wāhi haumarū, kei kō atu i te rori
- » hīkina te panati kia mōhio ai ngā tāngata kē atu kua pakaru tō waka, ā, kei te hia āwhina koe
- » whakakāngia ō rama mōreareatanga, whakamahia rānei he tapatoru haumarū hei whakatūpato i tāngata kē atu
- » i te pō, whakakāngia te rama o roto o te waka
- » mēnā kāore ō waea pūkoro, ā, kāore hoki e haumarū tō hīkoi, me tatari ki tō waka kia tae atu ai tētahi momo āwhina ki a koe
- » kua e tū i te rori
- » mēnā koe e hia āwhina ana i kaihautū kē atu, me whai kia nui te wāhi wātea e pai ai tā rātou tū.

Mēnā ka pakaru tō waka i tētahi huarahi matua:

- » me tūtohu, ka urungi ai i tō waka ki tētahi wāhi haumarū, kei kō atu i te rori – kei ohotata te whakatū i tō waka
- » hīkina te panati me te pūtu, ā, mēnā e taea ana, whakairihia tētahi mea mā ki te kakau o te kūaha, o te matapihi rānei i te taha kaihautū o te waka, hei whakaatu e hia āwhina ana koe
- » whakakāngia ō rama mōreareatanga, whakamahia rānei he tapatoru haumarū hei whakatūpato i ngā waka kē atu e ahu pēnā ana ki a koe
- » i te pō, whakakāngia te rama o roto o te waka
- » mēnā kāore ō waea pūkoro, ā, kāore hoki e haumarū tō hīkoi, me tatari ki tō waka kia tae atu ai tētahi momo āwhina ki a koe
- » kua e tū i te huarahi matua.

Ngā tukianga waka

Ka aroha hoki, heoi, he tukianga waka ka hua ake i ō tātou rori. Hei kaihautū pai, me mōhio koe ki ngā tūtohu e tohu ana e whakatata atu ana koe ki tētahi tukianga waka, ka mutu, he aha hoki ō haepapa mēnā ka whai wāhi atu koe, ka tūpono atu rānei koe ki tētahi tukianga waka.

Ngā tūtohu tukianga waka

I ngā wāhi o te tukianga waka, whakamahia ai pea e te pirihihana he tūtohu, he rama rarapa, he whakamuramura rānei hei whakatūpatō i kaihautū kē e ahu pēnā atu ana.

Ka whakatata atu ana koe ki tētahi wāhi tukianga waka, me whakapōturi, ka āta haere ai. Kua tūkati pea te rori, ā, he tangata kua whara e tīraha ana pea i te rori.

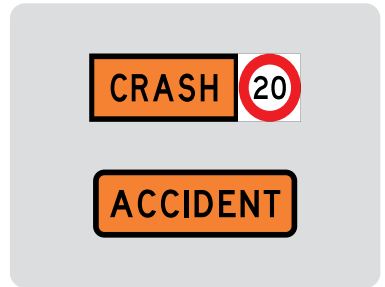

Meatia atu ai e te pirihihana ēnei tohu i kōtata atu ki te wāhi tukianga waka. Nō reira, me 20km/h, me pōturi ake rānei tō haere, kia tohipa rā anō koe i te wāhi tukianga waka. Kia tūpatō ki ngā kaimahi ohotata, me ngā tāngata kua whara.

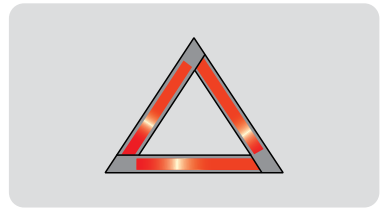

Te pānuī i tētahi tukianga waka

Mēnā koe ka whai whai wāhi ki tētahi tukianga waka i a koe e hautū ana, ā, kāore koe i whara kino nei, ko te mea tuatahi hei mahi māu, ko te tū me te whakaū mēnā rānei kua whara tētahi atu, ka mutu, ko te āwhina atu.

Mēnā kua whara tētahi, me wawe tonu tō whakamōhio i te pirihihana, ka mutu, me mātua pēnā i mua i te whakapaunga o te 24 hāora whai muri i te tukianga.

Mēnā kāore tētahi i whara, me wawe tō hoatu i tō ingoa, tō wāhitau, me tō tau waka, ka mutu, me mātua pēnā i mua i te whakapaunga o te 48 hāora whai muri i te tukianga. Hoatu ki:

- » ngā kaihautū rānei o waka kē atu kua pākinotanga, ki ngā tāngata rānei nō rātou rā aua waka
- » ngā tāngata nō rātou rā ngā rawa kua pākinotia.

Mēnā auare ake tō kimi i ēnei tāngata, me wawe tō whakamōhio i te pirihiimana, ka mutu, me mātua pēnā i mua i te whakapaunga o te 60 hāora whai muri i te tuinga. Mēnā kua inihuatia tō waka, me wawe tō whakamōhio i tō kamupene inihua whai muri i te tuinga.

Mēnā ehara i a koe te waka, ka mutu, ka tonoa koe, me hoatu hoki e koe te ingoa me te wāhitau o te tangata nōna te waka e hautū nā koe.

He kupu āwhina, ka pā ana he tuinga waka

Mēnā ko koe te tangata tuatahi ka tae ki tētahi tuinga waka, mā ō mahi e ora ai pea ngā tāngata i whai wāhi atu, e haumarua ake anō ai ngā kaihautū kē atu ka tūpono atu ki te wāhi tuinga waka.

Anei ētahi mahi e taea ana e koe hei whakahaumarua ake i te wāhi tuinga waka:

- » Whakatūria tō waka ki tētahi wāhi haumarua, kei wāhi kē atu i te wāhi tuinga waka. Me whai kia nui te wāhi wātea, e haere atu ai, e wehe atu anō ai ngā waka ohotata, hei wāhi mahi anō hoki mō ngā kaimahi ohotata.
- » Whakakāngia ngā rama mōreareatanga o tō waka.
- » Mēnā e taea ana, whakatūria he tangata, meatia atu ranei he tapatoru whakamataara ki ngā ara katoa e ahu atu ana ki te wāhi tuinga waka, hei whakatūpatō i ngā kaihautū e ahu pēnā atu ana. I tōna tikanga, kei te takiwā o te 200 mita te tawhiti i te wāhi tuinga waka, e whai wā ai ngā kaihautū e ahu pēnā atu ana ki te whakapōturi i ō rātou waka.
- » Mēnā he tangata kua whara, kia wawe te tonoa atu o te waka tūroro.
- » He wā ōna, kāore pea ngā pēkehau e whakamakoha. Kei uru koe ki waenga i tētahi pēkehau kāore i whakamakoha me te tangata kua whara, kua mau rānei. Ka whakamakoha pea ngā pēkehau, me te nui hoki o te tōpana, hei ētahi mēneti whai muri i te tuinga, me te aha, ka tūpono whara kōrua tahi.
- » Mēnā e haumarua ana tō pēnā, whakawetohia ngā waka katoa i whai wāhi ki te tuinga.
- » Mēnā he tohu utanga mōrearea tō tētahi waka i te tuinga, whāia ngā tohutohu mō ngā tuinga e whai wāhi atu ana ko ngā utanga mōrearea kei te whārangi 145.



Kia aronuitia

Waeahia ko 111 mō ngā ratonga ohotata. Waeahia ko *555 kia rīpoatahia ngā take rori.

Te tūāpapa o te whakaora ohotata

Ko te painga atu kia rēhita koe ki tētahi akoranga whakaora ohotata e whakautehia ana, kia ako ai i ngā pūkenga pērā i te aromatawai mātāmua me te whakaora manawa (CPR). Mā tēnei e māia ake ai, otirā, e kaha ake ai koe ki te whakatinana i ngā mahi whakaora ohotata, ina mate koe ki te pēnā.

Me whai kia kaua e neke i tērā kua whara

Mēnā kua whara te tuaiwi o tētahi, ka kino kē atu pea te wharanga ki te nekehia ia – kaua rawa e neke i tērā kua whara i te tuinga waka, mēnā ehara i te mea me mātua pēnā. Me neke noa i te tangata i mua i te taenga atu o ngā pūkenga whakaora mēnā:

- » kua mau te tangata i tētahi waka e kainga ana e te ahi, ka tūpono kainga rānei e te ahi
- » me mātua neke ia e pai ai tō karawhiu i ngā mahi whakaora manawa (CPR), hei puru rānei i te toto torohīhī.

Mēnā he kaieke motupaika tērā kua whara, kaua rawa e unu i tana pōtae mārō.

Te puru i te toto torohīhī

Mēnā e torohīhī ana te rere o te toto o te tūroro, me ngana koe ki te puru, ki te whakapōturi rānei i te rere. Whakamaua he karapu hei āraitanga, mēnā e taea ana, ka pēhi tonu atu ai i te tūnga, ko te painga atu ina whakamahia ai ko tētahi papanga mātotoru kua pōkaingia, pērā i te tāora, i tētahi momo kākahu rānei.

Ngā tuinga e whai wāhi atu ana ko ngā utanga mōrearea

Me tino tūpato i tētahi tuinga i whai wāhi atu rā ko tētahi waka kawē i ngā utanga mōrearea. Kaua rawa e ngana ki te whakarauora mēnā kāore koe e mōhio pū, e kore koe e pā ki ngā matū mōrearea. Kaua e whakatata atu, mēnā kāore koe e mōhio mēnā e haumarua ana.

Ko ngā mea matua e whā me aro e koe ka whakaahuatia ana tētahi tohu utanga mōrearea ki ngā ratonga ohotata ko:

- » Te tae o te tohu.
- » Te pikitia i roto i te tohu.
- » Ngā kupu i roto i te tohu.
- » Te tau kātū.



Te takahi ture

Ko tā ngā ture waka, he tiaki i te haumarutanga o ngā kaitāwhai katoa i te rori. Ka hāmenehia pea koe ki te hara koe i a koe e hautū ana.

Ngā piro whakawhiu

He piro whakawhiu te utu mō ētahi hara hautū, mō te hapa terenga hoki.

Mēnā ka eke ki te 100, neke atu rānei, te tapeke o ō piro whakawhiu i roto i te rua tau, ka whakatārewahia tō āhei ki te hautū mō ngā marama e toru. Me tuku rawa e koe tō raihana ki a Waka Kotahi.

Ka pūmau te whakakorehia o tō raihana hautū whai whakaahua, ka mutu, ka noho raihana kore tonu koe, ā, mutu noa ana te whakatārewatanga. Kāore e āhei tō hautū, kia whai raihana hou rā anō koe i tētahi āpiha whakaraihana.

E toro ki nzta.govt.nz/demerit-points

Te hautū kia tīrere, kia pokerenoa, kia mōrearea hoki

Ka mārō tonu tā ngā kōti aro ki tērā ka hautū kia tīrere, kia pokerenoa, kia mōrearea rānei.

Ka kapi pea i ngā whiunga ko:

- » te \$20,000 hei whiunga mōrahi
- » te 10 tau hei mauheretanga mōrahi
- » te whakakorehia o tō raihana hautū.

Te korenga i mau tātua nōhanga

Mēnā 15 tau, neke atu rānei tō pakeke, ā, ka hautū, ka haere rānei koe i tētahi waka, tē mau ai i te tātua nōhanga, e hē ana rānei tō whakamau, ka whiua pea koe.

Ka whiua hoki pea koe mēnā ko koe te kaihautū, ā, he pāhihi kei raro i te 15 tau kei tō waka kāore i te noho ki tētahi whakaita tamariki kua whakamanahia, kāore rānei ana tātua nōhanga, e hē ana rānei te āhua o te whakamau.

Te whakatārewatanga whakature o te raihana hautū mō te 28 rā

Ka whakatārewahia tō raihana i taua wā tonu mēnā:

- » ka mau koe i te pirihihana, e nui ake ana i te 40km/h te tere tuwhene, tēnā i tētahi paetere pūmau, e nui ake ana rānei i te 50km/h te tere tuwhene, tēnā i tētahi paetere taupua
- » ka oti i a koe tētahi o ngā hapa waipiro e kapi ana i te whakatārewatanga whakature.

E toro ki nzta.govt.nz/28-day-roadside-suspension

Te ōta aukati raihana hautū (DLSO)

Mēnā he whaina hautū, he utu rānei āu kāore anō kia ea, ka aukatingia pea tō raihana e Te Tāhū o te Ture mā tētahi ōta aukati raihana (DLSO). Ka mana te aukatinga kia whakapā atu rā anō koe ki Te Tāhū o te Ture, ka utu ai, ka whakarite ai rānei kia utua te nama e tāria tonutia ana. Ki te mau koe e hautū ana, ahakoa te DLSO, ka taumanutia pea te waka e hautū nā koe, ahakoa pea ehara i a koe, ā, ka whakakorehia hoki pea ko tō āhei ki te hautū.

Mō ētahi mōhiohio anō, whakapā atu ki Te Tāhū o te Ture ki 0800 434 637 (0800 4 Fines), e toro rānei ki justice.govt.nz

Te taumanu waka

Ka taumanu te pirihihana i tō waka i taua wā tonu mēnā ka mau koe:

- » e hautū ana ahakoa te whākorekoretia ōu
- » e hautū ana ahakoa te whakatārewatia o tō raihana
- » e hautū ana ahakoa te āta tohua ōu e te pirihihana kāore e āhei tō pēnā.

E tohea ai te taumanutia o tō waka, me whakapā koe ki ngā pirihihana.

Ka taumanutia tō waka mō te 28 rā, ā, ka whiua hoki koe e te kōti mōu i hara.

E toro ki nzta.govt.nz/28-day-roadside-vehicle-impoundment

Kia iti iho ngā pānga taiao o te hautū waka

Te hautū kia iti iho te kaikora me te tuku haurehu

Mā te hautū kia whāomo, ka iti iho te kora ka kainga e tō waka, otirā, ana tukuhanga para. Me whai koe:

- » kia tau te āhua o tō hautū, tē kaha whakahohoro ai, tē tumu mārō ai
- » kia karo i te tuwhene o te whakahuri i te pūkaha mā te whakawhiti ki nihowhiti kē
- » kia iti haere ngā haerenga poto – he 20 ōrau te āpitihanga kora ka kainga, ka makariri ana te pūkaha o tō waka
- » kaua e tuku kia rere noa te pūkaha o tō waka mō ētahi wā roa
- » kia kaua e kawē i te utanga kāore ōna tino take.

Me tiaki tō waka

Mā te tiaki i tō waka e iti iho ai tā tō waka kai kora, me te whakaputa parahanga. Me whai koe kia pai te rere o tō waka, kia tika hoki te whakamakoha hoki i ngā taea. Ko tā ngā tīrewa tuanui me ngā whakatōhenehene hau kāore i tika te whakapiri ki te waka he whakanui ake i te ātetetanga hau, me te kora ka kainga e te waka.

Ka hokona ana he waka

Me ngana ki te whiriwhiri i tētahi momo waka e iti iho ana te kaikora me te tuku haurehu kati mahana. E toro ki rightcar.govt.nz mō ētahi mōhiohio anō.

Whakaarohia ētahi momo hāereere kē atu

Me whai whakaaro ki te haere tahi me tangata kē atu, ki te whakamahi i ngā ratonga waka tūmatanui, ki te haere mā raro rānei, mā runga pahikara rānei.

Mō tō waka



Mō tō waka

Ngā herenga o te waka

Ākona ko ēhea ngā mea me whai wāhi atu ki tō waka e āhei ai tō hautū, tō whakatū rānei i te waka ki te rori.

Te whakamana pakari waka (WoF)

Ko ngā waka tūmataiti, motokā mai, waka paeuta mai, waka kōperu mai, waka 4-wīra mai rānei, me mātua whai WoF e mana tonu ana. Ko ngā waka ngaio me ngā waka taimaha, me mātua whai tiwhikete pakari waka (CoF) e mana tonu ana.



Ko tā te WoF e mana tonu ana, he whakaatu kua āta mātaitia te waka e tētahi kaimātai pakari waka kua whakamanatia, ka mutu, i te tika te āhua o te waka mō te rori i te wā o te mātaitanga WoF whakamutunga.

Me rapa te tohu WoF ki te mata whakaroto o te matapihi o mua, ki te taha kei reira rā ko te wīra urungi, ā, me mārāma te kitea atu i waho atu o te waka. Ko tētahi taunga pai, ko te koko o runga o te matapihi o mua.

Āpiti atu ana ki te WoF, ki te CoF rānei e mana tonu ana, me mātua kite i tō waka:

- » ko tētahi tohu raihana e mana tonu ana
- » ko tētahi raihana mō te utu whakamahi rori (RUC) mēnā e tika ana
- » ko tētahi tohu tau i mua, i muri hoki o te waka, e mārāma ana te kitea.

Kia aronuitia

Me āta tiaki koe i tō waka, e ū ai ki te taumata e tika ana mō te WoF i ngā wā katoa.

Ka whainahia pea koe mēnā ka hautū koe i tētahi waka kāore e eke ki te taumata WoF i runga rori. Ka āhei tā te pirihihana whakatū i a koe kia tirohia ai tō waka i te taha o te rori, ahakoa hei āhea.

Ngā āhuatanga me mātua kite i tō waka

E eke ai ki te taumata WoF, me pai te āhua o tō waka, hei tauira, kāore he waikura i ngā wāhanga haumarū, ka mutu, me pai te hanga o ngā taputapu e whai ake nei:

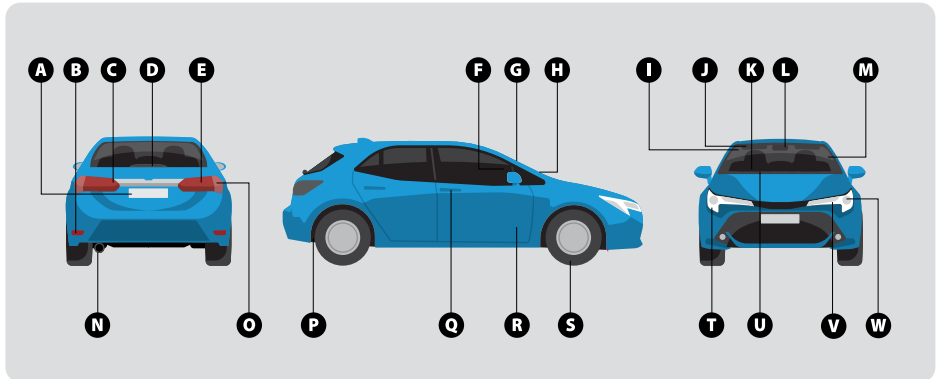

- A** He rama tohu tau i muri.
- B** Kia 2 ngā whakaata rama whero i muri.
- C** Kia 2 ngā rama tūnga whero i muri.
- D** Kia kotahi, kia 2 rānei ngā rama tumu whero i muri, kua titia ki te taha whakarunga.
- E** Kia 2, kia 4 rānei ngā rama tumu i muri.
- F** He hāona e kaha tonu ana.
- G** He matapihi o mua e hāngai ana ki ngā paearu haumarū, e mā ana hoki.
- H** Kia kotahi, neke atu rānei, ngā tāraikerake e kaha tonu ana.
- I** He WoF e mana tonu ana.
- J** He ārai rā pai.
- K** He pūnaha urungi e haumarū ana.
- L** He whakaata aro whakamuri e mārāma ana te tirohanga ki muri.
- M** He tātua e kaha tonu ana.
- N** He whakangū, he pūnaha whakaputa haukino anō hoki e kaha ana.
- O** He rama rarapa i muri, hei rama tūtohu ahunga.
- P** He kaupare paru.

- Q He kūaha e haumarua ana te huakina me te katia.
- R He whakatumu ā-wae, he whakatumu ā-ringa anō hoki e kaha ana.
- S He taea e haumarua ana – me 1.5 mitamano, nui atu rānei, te hōhonu o te tapore taea, huri noa i te taea. Mēnā kua meatia atu he taea takurua ki tō waka, me pērā ngā wīra rori e 4 o te waka, ka mutu, me 4 mitamano, nui atu rānei, te hōhonu o te tapore taea, huri noa i te taea.
- T He rama rarapa i mua, hei rama tūtohu ahunga.
- U He ine tere e kaha tonu ana.
- V Kia 2 ngā rama tūnga i mua, he mā, he tahetoka rānei te tae.
- W Kia 2 ngā rama ihuwaka e kaha ana, ka taea te whakakimo ina ahu pēnā atu tētahi atu waka ki a koe.

Kia mōhio mai: hei āwhina noa tēnei rārangi. Ka mātaihia ana tō waka, ka whāia e te kaimātai ngā paearu i te '*Vehicle inspection requirements manual*.'

E toro ki vehicleinspection.nzta.govt.nz

Ngā tātua nōhanga

Me mātua whai tātua nōhanga kua whakamanatia ngā waka taimāmā katoa ka kawē i te pāhihi – arā, ko te motokā, ko te waka kōperu, ko te waka paeuta, ko te waka 4-wīra anō hoki.

Me pai te hanga o ngā tātua nōhanga, nō reira, me wawe tō whai kia tirohia ngā tātua nōhanga o tō waka mēnā:

- » kāore ngā toromaka i te tino kaha
- » kua whakakinotia, kua kōrae rānei te tātua
- » kua tīmata te tāwekeweko haere o te tātua.

Kua tae pea te wā kia whakahoungia.

Kua panoni haere ngā here ā-ture mō te tātua nōhanga i roto i ngā tau, ā, ka rerekē e ai anō ki te tawhito o te waka. Kua huri anō hoki te momo tātua i te tātua toka, ki te tātua hautō.

Me mātua whakaurua atu ko te tātua kūhā pū-toru, me te tātua hauroki ki ngā nōhanga i ngā tahataha, tae atu ana ki te nōhanga o te kaihautū, i te nuinga o ngā motokā, o ngā waka kōperu, o ngā waka paeuta, me ngā waka 4-wīra. Ko ngā tātua pū-rua, ko ngā tātua kūhā rānei e whakaaetia ana ā-ture nei i te nōhanga o waenganui, engari, ka nui ake te haumarua ina mau kē ko te tātua pū-toru.

Me mau tātua koe, ka hautū ana. Me ita hoki te noho a te tamariki, mā te whakamahi i ngā whakaita tamariki kua whakamanatia. Tirohia te whārangi 140 mō ētahi mōhiohio anō.



Kia aronuitia

I mua i te panoni i ētahi āhuatanga ki tō waka, tae atu ki te whakapiri atu i ētahi rama āpiti ki tō waka, toro atu ki tētahi kaimātai WoF kua whakamanatia kia mōhio ai mēnā rānei e whakaaetia ana ngā panonitanga i raro i te ture.

Te whakautā me te tō mō te waka taimāmā

Ngā mea me mātua mōhio e koe e pā ana ki te tō

Ka tō ana i te tauaru, ka rerekē te āhua o te haere o tō waka i te rori. Mēnā he taumaha te utanga, ka roa ake te wā e horo ake ai, e pōturi anō ai te haere o tō waka. Mēnā he nui rawa te utanga, kua hē rānei te utahia o te waka, ka mōrearea, ka kumukumu hoki pea. Mēnā ka tō koe i tētahi mea ki tō waka, me mātua mārama ki ngā āhuatanga tūāpapa o te tō i te tauaru, kia haumarū.

E toro ki nzta.govt.nz/safe-towing mō te roanga atu o ngā aratohu.

Ngā hononga

- » Ko te hononga tō me te mekameka, te taura haumarū rānei e pupuri nei ki te tauaru, ki te waka rānei, me ita, me haumarū, me pakari anō hoki.
- » Me hāngai te rahinga o te pōro tō me te taputapu whakahono. E rua ngā rahinga e kitea ana i Aotearoa – ko te pōro rahinga whānui, 1 7/8" (47.55 mitamano) te nui, me tērā e 50 mitamano te nui. Mā te whakamahi i ngā rahinga rerekē, e wetekina ai pea te tauaru i te waka.

Ngā utanga

- » Kia mōhio mai, ki te nui rawa, ki te kūrēureu rānei ngā utanga i ngā tauaru waka, ka raru kino nei pea ko te āhua urungi o te waka.
- » Ka hautū ana i te waka taimāmā, me tō i te tauaru anake, i te waka kotahi anake rānei i te wā kotahi, kia kaua e nui atu i tērā.

Ngā rama

- » I te pō, me mārama te kite atu i tētahi rama whero i te wāhanga o muri o te tauaru, o te waka rānei e tōia ana.

Te terenga

- » Ko te tere mōrahi e whakaaetia ana mō te waka taimāmā e tō ana i te tauaru i te rori tuwhera ko te 90km/h.

Te aroā

- » Me mārama tō kite ki muri atu o te tauaru, o te waka rānei e tōia ana. Mēnā kāore e kitea ana a muri mā ngā whakaata aro whakamuri, ka mate pea koe ki te tāuta i tētahi whakaata motuhake.
- » Kia nui ake te wāhi wātea i mua i tō waka me tērā kei mua i a koe, e taea ai te tohipa a waka kē atu i a koe.

- » Nā te taumaha āpiti o te utanga i muri i a koe, he nui ake te wāhi ka hiahiatia kia whakatūria tō waka.
- » Me whakaroa tō tawhiti whaiwhai i te 2 hēkena ki te 4 hēkena.
- » Ka pōturi ake, ka iti iho hoki te tūwhena o tōu waka i a koe e tō ana, tēnā i tō waka kē atu. Kia rite tonu tō tiro whakamuri, kia mōhio ai mēnā he waka kē atu e mau ana i muri i a koe.
- » Mēnā e kōpikopiko ana, e whāiti ana rānei te rori, ā, kāore e taea tā waka kē atu tohipa i a koe, me tū koe ki tētahi wāhi haumaruru, ka tuku ai i ērā atu waka kia tohipa.



Kia aronuitia

Mēnā e tō ana koe i tētahi tauaru, i tētahi atu waka rānei, kia rite tonu te tiroiro i tō whakaata aro whakamuri, kia whakaū ai kāore koe i te whakapōturi i ngā waka kē atu kei muri i a koe.

Te tepenga taumaha

Mēnā he raihana ako, he raihana here rānei tāu i te kātū 1, e āhei ana tāu tō i te tauaru, engari me kaua te tapeke taumaha o tō waka, o te tauaru, me ngā utanga e taumaha ake i te 4500 kirokaramu.

Mēnā he raihana matua tōu, me kaua te tapeke taumaha o tō waka, o te tauaru, me ngā utanga e taumaha ake i te 6000 kirokaramu.

Te kawē utanga ki runga tonu o tō waka

- » Kia kaua e tūrākaha rawa tō tīrewa tuanui.
- » Me kaua te toronga o tō utanga e roa ake i te 3m ki mua i te pito whakamua o te tūru o mua, me te 4m ki muri atu i te paewīra o muri.
- » Me kaua te toronga o tō utanga e roa ake i te 1.275 mita ki ia taha, nō te pito waenganui o te waka.

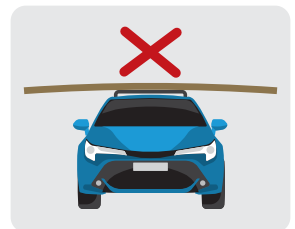
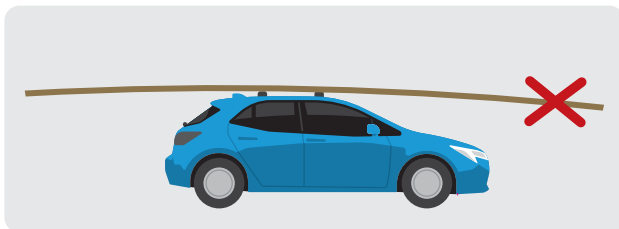

Kia mōhio mai: Mēnā ka nui ake te toronga o te utanga i te 1 mita ki muri i tō waka, i ngā hāora e ao ana te rā, me here tētahi haki mā, tētahi haki rānei e kōrekoreko ana, he whero, he karaka, he kōwhai rānei te tae. Ka pō ana, me whakakapi te haki ki te rama.

Me 40 henemita x 30 henemita, nui atu rānei te rahi o te haki. Me here te utanga kia ita, ka mutu, me kaua rawa e pā ki te papa.

Me kaua e roa ake i te 4 mita te tawhiti i waenga i tō waka me te tauaru, te waka rānei e tōia ana.

Ngā here mō te tauaru taimāmā

Ki te tō koe i te tauaru taimāmā (ka 3500 kirokaramu iti iho rānei te taumaha, ka utahia ana), me whai raihana, me whai whakamana waka (WoF) hoki. E eke ai ki te taumata WoF, me pai te āhua o tō tauaru (kāore he waikura i ngā wāhi whakahaumaru), ka mutu, me pai te hanga o ngā taputapu e whai ake nei:

Ngā āhuatanga me kite i tō tauaru taimāmā

- A** He taputapu whakahono, he mekameka, he taura haumaru rānei e haumaru ana, e kaha ana anō hoki.
- B** He pae tō, kāore ana whakakinotanga, kāore hoki i pūnguru.
- C** Mēnā e whānui ake ana te tauaru, ana utanga rānei, i te 2 mita, me tāuta ngā rama mā e rua ki mua hei whakaatu i tana whānui.
- D** Ngā taea haumaru - me 1.5 mitamano, nui atu rānei te hōhonu o te tapore taea, huri noa i te taea.
- E** Ngā kaupare paru.

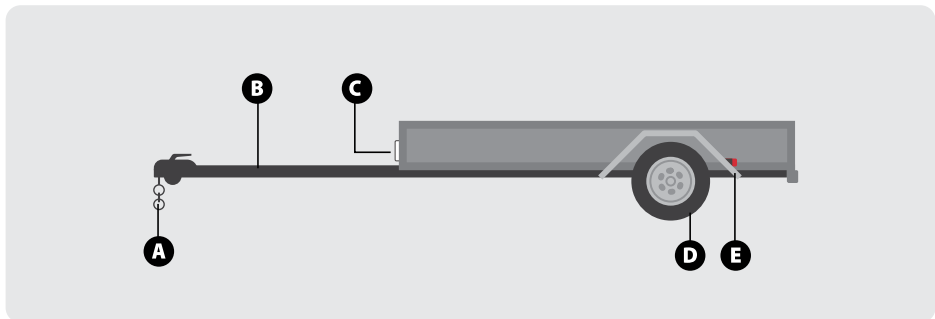

Kei te āhua o te tau rēhita, me whai hoki tō tauaru i ngā mea e whai ake nei:

- F** Kia kotahi, kia 2 rānei ngā rama hikuwaka whero, hei whakaatu i te whānui.
- G** Kia 2 ngā rama tumu whero i muri, mēnā kāore e kitea ana ngā tūtohu a te kaihautu.
- H** He rama tūtohu ahunga i muri.
- I** He whakamana waka (WoF), nā te kaimātai WoF i whakaū.
- J** He tohu tau i muri.
- K** Me tāuta he tohu rēhita e mana tonu ana, kia pātata ki te tohu tau.
- L** Kia 2 ngā whakaata rama whero i muri (ko tētahi ki ia taha).

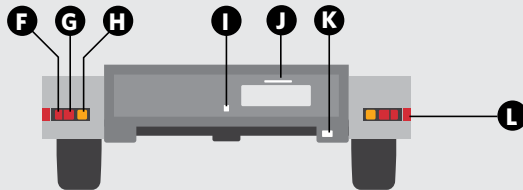

Te uta i tō tauaru kia haumaruru ai

E tūwhena ai te waka me tana tauaru i a ia e tō haere ana, me hāngai tō te tauaru tōpana whakararo ki te pae tō o te waka ki tōna 10 ōrau o te tapeke taumaha o te tauaru me ana utanga.

Me kauhia e roa ake i te 4 mita te toronga o te utanga i te tauaru ki muri atu i te paewhira.

Me kauhia e roa ake i te 1.275 mita te toronga o te utanga i te tauaru ki ngā taha e rua, nō te pito waenganui o te waka.

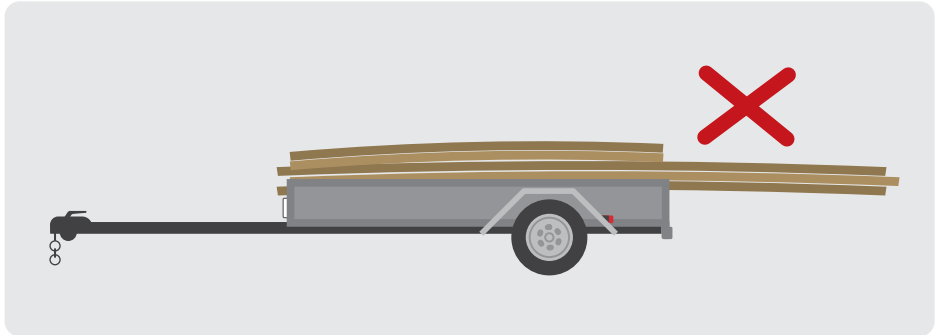
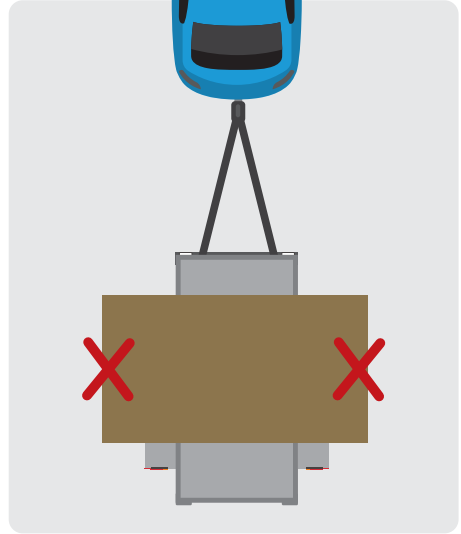

Mēnā ka roa ake te toronga o te utanga i te 1 mita ki muri i te tauaru, i ngā hāora e ao ana te rā, me here tētahi haki mā, tētahi haki rānei e kōrekoreko ana, he whero, he karaka, he kōwhai rānei te tae. Ka pō ana, me whakakapi te haki ki te rama. Me 40 henemita x 30 henemita, nui atu rānei te rahi o te haki. Me here te utanga kia ita, ka mutu, me kauhia rawa e pā ki te papa.

E toro ki nzta.govt.nz/motorhomes-caravans-light-trailers mō ētahi mōhiohio anō.

Mō kaitāwhai kē atu i te rori



Mō kaitāwhai kē atu i te rori

Te haere tahi i te rori

Ehara i te mea ko te motokā me ērā tū waka anake kei ō tātou rori – he nui ngā momo kaitāwhai kē atu, e kapi ana i tērā ko ngā waehīkoi, ko te hunga eke pahikara, eke hōiho anō hoki.

Ākona mō kaitāwhai kē atu, me pēhea hoki te haere tahi ki a rātou i te rori.

E toro ki nzta.govt.nz/sharing-the-road mō ētahi mōhiohio anō.

Te haere tahi i te rori ki te waehīkoi

I tōna toharite, 36 ngā waehīkoi ka mate, 1000 ka whara i ngā rori o Aotearoa i ia te tau.

He nui ēnei matenga, ēnei wharanga hoki ka taea te karo ina tūpatō ake ngā kaihautū waka i ō tātou rori. Tēnā, kia mataara ki te waehīkoi ka hautū waka ana koe.

Te whakahaumarū i te waehīkoi, mā te kaihautū

- » Kia takatū ki te tū ka pātata ana ki te kura, ki te tūnga pahi, me ngā whakawhitinga waehīkoi.
- » Kia tūpatō ka tohipa ana i ngā waka kua whakatūria. Ka matawhawhati pea te puta a te waehīkoi.
- » Whakapōturihia tō haere kia 20 kiromita i te hāora i a koe e tohipa ana, e whakatata ana haere ana rānei ki tētahi pahi kura kua tū hei tuku i ngā tamariki kia eke, kia heke rānei, ahakoa kei tēhea taha o te rori koe e haere ana.
- » Kia aronui ki te hunga kaumātua, me te hunga whaikaha.
- » Kia tūpatō ka tata ana ki ngā tūnga hokohoko i ngā tahataha rori. Ka mahue pea e te waehīkoi e toro ana ki ēnei wāhi te aronui atu ki ngā waka ka whakawhiti ana ia i te rori.

Ngā whakawhitinga waehīkoi

Ko te whakawhitinga waehīkoi, ko tētahi wāhanga o te rori e tohungia ana tōna whānuitanga ki te tāhei mā. Hei whakamahi tēnei mā te waehīkoi, mā te hunga hoki e eke taumatua neneke ana, pērā i te tūru-wīra e whai pūrere ana, tae atu ki te papa-wīra, me te kutapana.

He motu koutu i ētahi whakawhitinga hei tūnga mō te waehīkoi. Hei āwhina ēnei i te waehīkoi ki te whakawhiti i ngā rori ahunga rua mēnā e whānui ana, i ngā rori ara-tini rānei.

Ka whakatata atu ana koe ki tētahi whakawhitinga waehīkoi, ka kite koe i ngā tohu whakawhitinga waehīkoi i mua i te whakawhitinga, me ngā pou pango me te mā ki te whakawhitinga tonu. He kōpae karaka kōrekoreko tō ia pou, he rama kōwhai rānei, he porotaka te hanga, ka raparapa i te pō. I te nuinga he taimana mā ka peitahia ki te rori i mua i te whakawhitinga, me tētahi rārangi taepa, e whakaatu ana ki a koe me tū ki hea.

Ka whakatata atu ana koe ki tētahi whakawhitinga waehīkoi:

- » me whakapōturi tō haere, kia rite hoki ki te tū mō te waehīkoi i runga kē, e whakaeke ana rānei i te whakawhitinga – tae atu ki te hunga e mārama ana te kitea kei te whanga ki te whakawhiti
- » mēnā kāore he motu koutu i waenga i te whakawhitinga, me tū, me tautuku hoki ki te waehīkoi, ahakoa ki hea i te whakawhitinga
- » tāria kia whakawhiti atu te waehīkoi i mua i a koe, ki tua atu o tō waka, ka koke anō ai koe.

Mēnā kei tētahi rārangi waka koe e pātata ana ki tētahi whakawhitinga waehīkoi, kua koe e whakawhiti atu mēnā kāore e ō te roanga o tō waka ki tērā atu taha o te whakawhitinga.

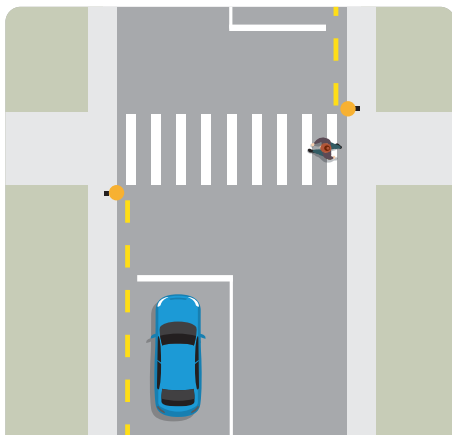

Te whakawhitinga waehīkoi

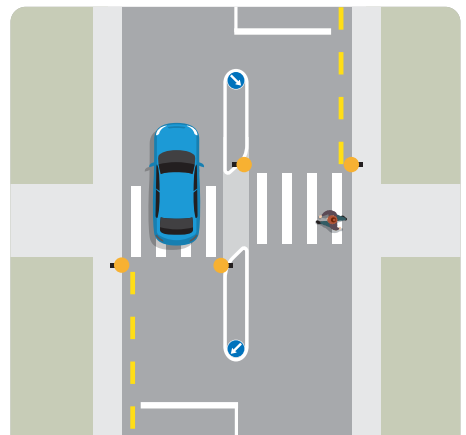

Te whakawhitinga waehīkoi me te motu koutu

Mēnā he motu koutu i waenga i te whakawhitinga, me tū koe, ka tautuku ai ki ngā waehīkoi i tō taha o te rori.

Ngā whakawhitinga atawhai

Ahakoia ehara i te whakawhitinga waehīkoi ōkawa, ko te whakawhitinga atawhai he wāhi e haumarū ai tā te tangata whakawhiti. Me ngākau atawhai koe ki ngā tāngata e whakamahi ana i te whakawhitinga atawhai.

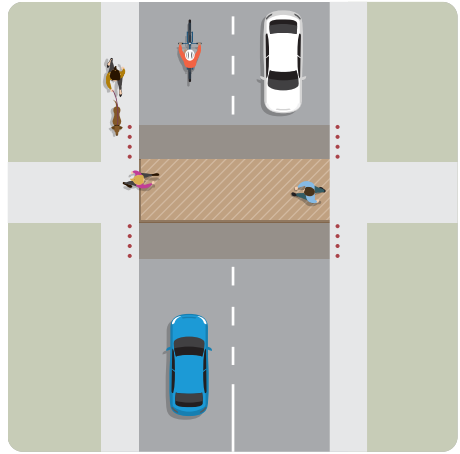

Kia aronuitia

Kaua rawa e tohipa i tētahi waka e whakapōturi ana i tana whakatata atu ki tētahi whakawhitinga waehīkoi.

Ngā whaitua matatini

He rori tēnei hei whakapōturi i te rere o te waka, hei whakamātāmua hoki i te waehīkoi. Ko ngā kaihautū waka me tautuku ki ngā waehīkoi, ko ngā waehīkoi me whai kia kaua e aukati i te rere o ngā waka.

He whakawhitinga kura

Ko ngā whakawhitinga kura, ka kīia hoki he whakawhitinga kea, hei wāhi e haumarū ai te whakawhiti a ngā tamariki i te rori. I te nuinga o te wā, ka tū noa aua whakawhitinga i mua, i muri hoki i te kura.

Ka tū ana te whakawhitinga kura, ka whakaatuhia tētahi tohu tamariki he karaka kōrekoreko te tae, me tētahi tohu SCHOOL PATROL STOP, ka toro haere ki te rori i ōna wā.

Ka torona atu ana te tohu SCHOOL PATROL STOP ki te rori, me tū ngā waka i ngā ahunga e rua kia tōia atu rā anō aua tohu katoa.

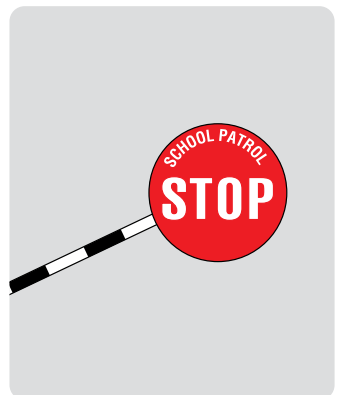

Kia mōhio mai mō ngā tamariki

- » Ehara te tamariki i te pakeke, nō reira kei pōhēhē ka pakeke ana whanonga.
- » Kāore pea ngā tamariki, inarā ko ērā kāore anō kia 9 ngā tau, e whai pūkenga ana e haumarū ai rātou i te rere o ngā waka. Kia tūpato ka pātata ana tō hautū waka ki a rātou.
- » He whāiti te tirohanga tamariki, kāore pea e pērā te mārama o tana kite i ngā waka i tā te pakeke.
- » He uaua ki te tamariki te whakapae i te tere o te haere o te waka. Ka tāria pea te tohipa o tētahi waka pōturi, kātahi ka whai kia whakawhiti atu i mua i tētahi waka tere.
- » Me uaua ka mārama ki te tamariki me whai wā e tū ai tētahi waka.
- » Ka uaua pea ki te tamariki te whakatau i te takenga mai o ngā oro ka rangona e ia.
- » He nohinohi nō te tamariki, he nui ngā wā ka taupāngia te titiro ki tua i ngā puihi, i ngā waka rānei kua whakatūria i ngā tahataha rori. Ka uaua hoki te kitea o rātou e ngā kaihautū waka.
- » Ka uaua pea ki te tamariki te tū ki te taparori, ka puta poka noa atu pea ki te rere o ngā waka.
- » Ka toka te tū a ētahi tamariki ka rongō ana i te mōrearea, tērā i te tere hohe a te pakeke.

Kia mataara ki ngā tamariki i ngā wā katoa. Kia tūpato ka hautū waka ana i te 8-9 karaka i te ata me te 3-4 karaka i te ahiahi, i ngā tamariki e haere atu ana ki te kura, e hoki mai ana rānei.

Ngā waehīkoi e kāpō ana, e atarua ana rānei

He rite tonu te whakamahi taumatua a te hunga kāpō, a te hunga atarua rānei, pērā i te tokotoko mā, i te kurī arataki rānei. Kia kite koe i tētahi e whakamahi ana i ēnei taumatua e whai ana ki te whakawhiti i te rori, kia tūpato, ā, tukuna rātou kia āta whakawhiti.

I te kuhu, i te puta rānei i ngā ara urunga

Ka whakawhiti ana tō waka i tētahi ara hīkoi, pērā i te kuhu, i te puta rānei i te ara urunga, i te tūnga waka rānei i te hokomaha, me tautuku koe ki ngā tāngata i runga i te ara hīkoi.

Ka puta ana koe i te ara urunga, me tautuku ki ngā waka i te rori.

Te haere tahi i te rori ki te hunga eke pahikara

He āhua whakaraerae ngā kaieke pahikara i te rori, i te mea he uaua te kitea, kāore hoki i te pērā rawa te whakamarumarutia ōna i tō ētahi atu kaitāwhai i te rori. Kia mataara ki ngā kaieke pahikara i te rori, me āta hautū hoki ka pātata ana koe ki a rātou.

Te hautū kia haumarū ai te hunga pahikara

- » He mōreareatanga e tataha haere ai pea te kaieke pahikara i tōna ara ki tōhou, pērā i te waka kua whakatūria, i ngā kōhao rori, i te karaihe, i te para, i te hau pūkeri me te whakatuwheratanga o ngā kūaha waka. Tukua kia nui te wāhi ki ngā kaieke pahikara i a koe e tohipa haere ana i a rātou – kia 1.5 mita, nui atu rānei te āputa, mēnā ka taea.
- » Ina whāiti te rori, tāria kia wātea, ka tōhipa ai i te kaieke pahikara.
- » I ngā pūtahi, kia rite tonu tō ū ki ngā ture mō ngā kaieke pahikara i tērā mō ērā atu waka i te rori.
- » Ki te whakawhiti atu koe i te ara pahikara, me tautuku ki te kaieke pahikara, ka whakawhiti atu ai.
- » Kia tūpato ki ngā tamariki e eke pahikara ana.
- » Kaua rā e hautū waka i tētahi ara pahikara, kaua hoki e whakawhiti atu i te ara pahikara, hāunga rā i tētahi 50 mita, poto iho rānei i a koe e kuhu ana, e puta ana rānei i te ara peka, i te ara urunga, i te tūnga waka rānei.
- » Kaua rā e tū, e whanga, e whakatū rānei i tō waka i te ara pahikara.

Ka tohu ā-ringa pea te kaieke pahikara hei tūtohu i ana whāinga

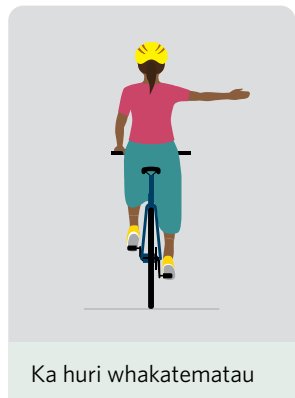
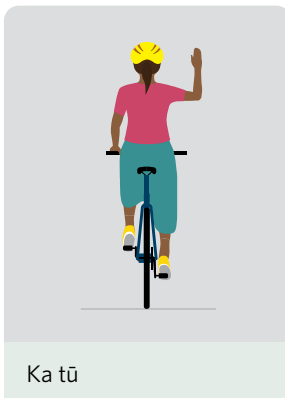
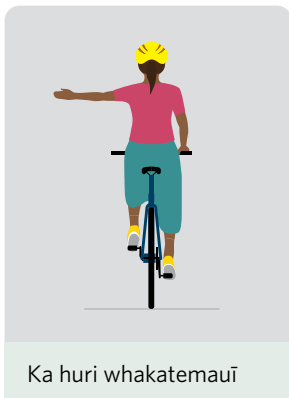

Ngā pūtake auau o te tukinga pahikara

Te koke, te huri rānei ki te pūtahi

He wā ōna ka uaua te kite i te kaieke pahikara i te rori. Kia rite tonu tō tiro tiro mēnā he kaieke pahikara, ka huri ai, ka koke ai rānei koe ki tētahi pūtahi. Mēnā e whai ana koe i tētahi kaieke pahikara, ā, ko te huri whakatemauī tō hiahia, tāria kia hipa atu te kaieke pahikara i te pūtahi. I ngā pūtahi e kapi ana i te waka, ka whakatau pea te kaieke pahikara kia huri whakatematau mā tētahi huri matika. I te huri matika, ka tōtika tana haere mā te ara mauī, ka tū ai ki te taha mauī o te rori, ka tāria he āputa i te rere o ngā waka, te huringa rānei o ngā rama pūtahi.

Te whakatuwhera i te kūaha waka

Ka whara pea te kaieke pahikara ina pokaina tōna ara e te whakatuwheratanga o tō kūaha. I ngā wā katoa me mātua tiro tiro atu mēnā he kaieke pahikara i mua i tō whakatuwhera i tō kūaha. Whakatuwherhia te kūaha ki tō ringa mauī – mā te pēnei ka huri ō pokohiwi, me kore noa e māmā ake ai tō kite i te kaieke pahikara e ahu pēnā atu ana.

Te haere whakamuri, te puta rānei i ngā ara urunga, i ngā tūnga waka rānei

Kia rite tonu tō āta mātai atu i te rori mō te kaieke pahikara, ka haere whakamuri ai, ka puta ai rānei i te ara urunga, i te tūnga waka rānei.

I tō puta i te ara urunga, i te tūnga waka rānei, me tautuku koe ki ērā atu waka i te rori.

Te tohipa i ngā tira eke pahikara

Tukuna kia nui ai te wāhi ki a rātou, kaua e pātata rawa.

Kia mōhio mai, mō te kaieke pahikara

- » He iti noa iho te pahikara, he uaua hoki te kitea, inarā i te pō. Kaua rā e aro ki ngā waka nui anake pērā i te motokā.
- » Ka wehi pea ngā kaieke pahikara ina pakirara te hautūtanga waka. E mana ana tā rātou whai wāhi i te rori, ā, me whai wāhi i ngā pūtahi, i ngā pūtahi porotaka anō hoki.
- » Ka tawhiti pea te haere a te kaieke pahikara i ngā taparori, ka noho rānei ki te ara tonu o te rori - kaua hei whakapōrearea kaihautū, engari kia:
 - › karo i te waikari, i te kōhao rori, i ngā para rānei i te tahataha rori
 - › mārama tō rātou kitea ka tata haere ana ki te pūtahi e whai ara peka ana
 - › akiaki i ngā kaihautū waka kia kaua e kōpē rawa te tohipa i ngā wāhi e mōrearea ana, pērā i ngā rori whāiti.

- › E noho whakaraerae ana ngā kaieke pahikara e huri whakatematau ana. Me āta tiaki e ngā kaihautū, inarā i ngā rori ara-tini, ina tere te rere o ngā waka.
- » Ka panaia pea ngā kaieke pahikara ki ngā ara kei reira rā ngā waka tere ake, ina whakatūria ngā waka ki ngā wāhi kāore nei i te tika, pērā i:
 - › ngā ara pahikara
 - › ngā rārangi kōwhai nakunaku
 - › ngā wāhi e pātata ana ki te pūtahi.
- » Ka pohepohe te kaieke pahikara i ngā rama ihuwaka e mārama taiahoaho ana, pērā i kaitāwhai kē atu i te rori - me maumahara ki te kimo i ngā rama ki ngā kaieke pahikara anō hoki.
- » Ka hohoro pea te haere o ngā kaieke pahikara, ko te 40km/h, tere atu rānei ka taea.
- » E mana ana tā te kaieke pahikara whakamahi i ngā rori, kia haumarua hoki, kia pārekareka hoki tana haere. Me whakaute ō rātou matea i ngā rori, ka tika.

Te haere tahi i te rori ki te taraka me te pahi

Te whai i te taraka, i te pahi hoki

- » Kia maumahara ki te tikanga 2-hēkena - ki te pātata rawa tō whaiwhai ake, ka uua tō kite atu i te ara kei mua, ka poto iho te wā ki a koe hei whakatū i tō waka, ā, ka noho pea koe i ngā whaitua huna o te kaihautū i te taraka, i te pahi rānei.
- » Ka ua ana, whakaroatia tō tawhiti whaiwhai kia 4 hēkena ai te roa. Mā konei koe e tawhiti ai i te wai ka uwhiuwhi mai i ngā wīra, ka roa ake hoki te wā hei whakatū i tō waka.
- » He nui ngā whaitua huna o te kaihautū i te pahi, i te taraka hoki, i muri, i ngā tahataha hoki o tana waka. Kia tika te tawhiti o tō noho ki muri i a ia e taea ai te kitea ōu mā ā rātou whakaata tahataha. Mēnā e kite ana koe i ā rātou whakaata, ka taea hoki tā rātou kite i a koe.

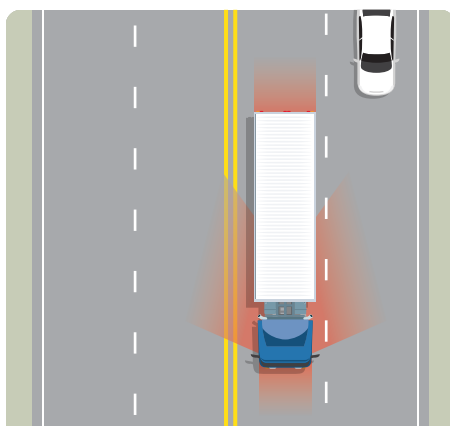

Ngā whaitua huna o te kaihautū taraka

Te tohipa i te taraka me te pahi

E hia kē nei ngā hēkena me āpiti, e tutuki ai tō tohipa i te taraka, i te pahi rānei, tērā i te motokā noa iho. Whakaūngia kua tika te roa o te wāhi e puare ana i mua i a koe, e taea ai tō tohipa atu, me te kore e whati i te paetere e tika ana. Tirohia te whārangi 57 mō ētahi mōhiohio anō mō te tohipa.



Kia aronuitia

Mēnā kāore koe e kite ana i te kaihautū o te taraka, o te pahi rānei i tana whakaata tahataha, kāore hoki koe e kitea ana e ia.

Ngā taraka me ngā pahi e ahu mai ana

He nui ake te wāhi i te rori ka riro i te taraka me ērā atu waka kaitā. Kāore pea e ū katoa ki tōna anō ara i ngā hurihanga me ngā pūtahi.

Ka tohipa ana i tētahi taraka, i tētahi pahi rānei e ahu kōaro ana, puritia te urungi kia mau, kei kakare te hau.

Te haere tahi i te rori me te tarakihana

He wā ōna ka kite koe i te tarakihana, i ērā atu momo pūrere ahuhenua, hangatanga rānei i runga i te rori. Nā te kaitā rawa atu, me te pōturi iho o te haere i tō waka kē atu, me tino tūpato ka pātata ana tō waka.

- » Me tīmata tō whakapōturi haere ka kite ana koe i te tarakihana i mua i a koe, kia mataara hoki ki ōna rama whakatūpato.
- » Kia manawanui – he pai noa ake te āta haere mō ētahi mēneti ruarua, tērā i te tūraru nui ka hua ake he tuinga waka.
- » Kia tūpato i a koe e tohipa ana, ā, tāria kia haumarū, kia whai tikanga hoki ka pērā ai.
- » He rite tonu tā te tarakihana kawē i tētahi utanga whānui, whāroa rānei, e uaua ai te tohipa.
- » Kia tūpato ki te tarakihana kātahi anō ka tū, i te mea e whakarite ana pea ia ki te huri.

Te haere tahi i te rori ki te waka whakahara

He wā ōna ka kite rā koe i te waka whakahara, pērā i te waka kawē whare, i runga i te rori. Nā te kaitā, me te pōturi iho o te haere i tō waka kē atu, me tino tūpatō ka pātata ana tō waka.

- » I te nuinga o te wā, ka wawe te whakatūpatōhia ōu mō ngā waka tino kaitā rawa atu, nā te mea ka haere tahi me te waka ārahi, hei whakatūpatō i a koe (tirohia ngā whārangi 34-35). He tohu mōreareatanga, he rama hurihuri, he haki anō hoki ō te waka whakahara.
- » Whakapōturihia tō haere, ka whakarite ai ki te whai i ngā tohutohu a te waka ārahi.
- » Kia manawanui – he pai noa ake te āta haere mō ētahi mēneti ruarua tērā i te tūraru nui ka hua ake he tukuinga waka.
- » Kia tūpatō i a koe e tohipa ana, ā, tāria kia haumarū, kia whai tikanga hoki ka pērā.

Te haere tahi i te rori ki te kaieke motupaika

Ka māmā noa te neke a te kaieke motupaika, engari ka uaua te kitea, nō reira he nui ake te whakaraerae. He mea nui:

- » te mātua tiro i ō whakaata, ki ō whaitua huna anō hoki, ka huri ai
- » te mātua tiro whakamuri, ka whakatuwhera ai i tō kūaha, ka whakawhiti ara ai rānei
- » te mōhio kāore e aunoa te wetō o ngā rama tūtohu i te nuinga o ngā motupaika – kaua e pōhēhē i te rama tūtohu e kā tonu ana
- » te mōhio ka hiahia te kaieke motupaika i te whānuitanga o te ara i ngā wā katoa. Whāia nei pea ka tataha, ka whakapōturi rānei i tana haere, kia karo i ngā mōreareatanga rori.

Te haere tahi i te rori ki ngā kaieke hōiho

Tēnā, kia ngākau atawhai ka haere tahi ana i te rori me ngā hōiho. Ka māmā noa te tūmeke o te hōiho, nō reira me kotahi atu ki te whakatika i tō hautū waka ka kite ana koe i te hōiho i te rori i mua i a koe.

Te hautū kia haumaru i ngā hōiho e pātata ana

- » Whakapōturihia tō haere, ka āta tohipa, kia nui ai te wāhi ki te hōiho me tana kaieke.
- » Kaua e whakatangihia tō hāona, tō pūrere rānei, kaua rānei e tere te tohipa.
- » Mēnā kei tētahi arawhiti, kei tētahi rori whāiti rānei te hōiho me tana kaieke, kia tino tūpato – me whakapōturi, me tū rānei.
- » Ki te wehi te āhua o te hōiho, e tū.
- » I te pō, me kimo ō rama ihuwaka ka pātata haere ana ki tētahi hōiho.
- » Kaua e tohipa i tētahi anō waka ka pātata ana ki tētahi hōiho.



Kia aronuitia

Kia tūpato ka pātata ana ki ngā hōiho i te rori. Ki te kore, ka hāmenetia koe mō te pōrahu, mō te mōrearea o tō hautū waka.

He mōhioho mō kaitāwhai kē atu

He aratohu whānui mā te waehīkoi

Ngā ara hīkoi

- » Ko ngā ara hīkoi he wāhi e haumarua ai tō hīkoi – mēnā he ara hīkoi, whakamahia.
- » Mēnā kāore he ara hīkoi, me hīkoi i te taha o te rori e aro atu ana ki ngā waka e ahu mai ana. Kaua e takahia te rori mēnā ka taea, me whai rānei kia ū ki ōna tapanga. I ngā koki, ko te painga atu ina hīkoi i te tapanga o waho o te kōpiko.
- » Ka haere ana mā tētahi ara matatini, me tūpato, me aronui hoki. Ko te ara matatini, he ara hei whakamahi mā te hunga e hīkoi ana, e eke ana rānei i te pahikara, i te kutahiko rānei, i te taumatua neneke rānei. He tohu i reira e whakamōhio atu ana i a koe he ara matatini tērā.
- » Kia tūpato ka whakawhiti ana i ngā ara urunga, inarā e hunaia ana pea koe e te whare, e te taepa rānei. Kāore pea koe e kitea e tētahi kaihautū waka e puta ana mā te ara urunga.
- » I te pō, me mau kākahu e teatea ana te tae, e kōrekoreko ana rānei, puritia rānei he rama e mārama ake ai te kitea ōu.

Te whakawhiti i te rori

- » Me haumarua rā anō te rori e whakawhiti atu ai koe. Kia rite tonu te tiro tiro mō ngā waka ki ngā rori katoa e pātata ana i mua rā i tō whakawhiti atu, ā, kia tere te kotipū i taua rori rā. Ki te whakawhiti i tētahi pūtahi, tirohia a muri, a mua hoki mō ngā waka e huri ana.
- » Me whai wā e tū ai tētahi waka, nō reira tāria tētahi āputa i te rere o ngā waka, ka whakawhiti atu ai koe.
- » Ki te hiahia koe ki te whakawhiti atu i te rori i tō hekenga i tētahi pahi, tāria kia neke atu te pahi, kātahi ka tiro tiro mō ngā waka e haere ana.
- » Ki te whakawhiti koe i te rori i waenga i ētahi waka kua whakatūria, me neke ki te taha o te rama ihuwaka e pātata katoa ana ki te rere o ngā waka, ka tirohia ai mō ngā waka e haere ana, ka tāria ai ko tētahi āputa, kātahi ka whakawhiti atu.
- » Ko ngā tamariki nohinohi me pupuri i te ringa o tētahi tangata e pakeke ake ana.
- » Ki te whakawhiti rori i te pō, kia tata ki tētahi rama tiriti ka pērā ai, mēnā rā ka taea.

Ngā whakawhitinga waehīkoi

- » Mēnā he 20 mita, iti iho rānei tō tawhiti atu i te whakawhitinga waehīkoi, i te arawhata waehīkoi, i te ara whitiraro, i te rama pūtahi rānei, me whakamahi e koe hei whakawhiti i te rori.
- » Kaua e tarioi ki tētahi whakawhitinga waehīkoi.
- » Kaua e puta whawhati tata atu ki tētahi whakawhitinga waehīkoi mēnā he pērā rawa te tata o te waka ki te whakawhitinga, tē āhei tana tū.

Rama tūtohu waehīkoi



Kaua e whakawhiti



Kia tere te whakawhiti



Kaua rā e tīmata, engari mēnā kua tīmata kē, me whakaoti te whakawhiti

Ngā whakawhitinga atawhai

Ehara te whakawhitinga atawhai i te whakawhitinga waehīkoi ōkawa. He wāhi e haumarū ai te tū a te kaihautū waka, hei tuku i te waehīkoi kia whakawhiti atu. Heoi anō, ehara i te mea me tū te kaihautū ki te whakawhitinga atawhai, nō reira kia tūpato ka whakamahia ana.

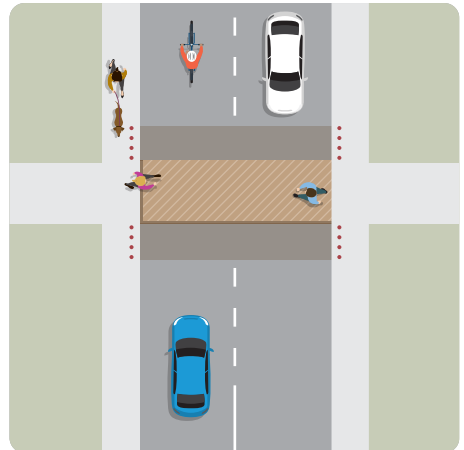

Ngā kaiomaoma

- » He wā ōna ka uaua tā te kaihautū waka kite i a koe e omaoma ana. Kia muramura ō kākahu, kia kōrekoreko hoki ngā tātua, ngā tauri rānei.
- » Kia ū ki ngā tikanga rori e hāngai ana ki ngā waehīkoi.
- » Kia tino tūpato ki ngā pūtahi.

Hei āwhina i ngā mātua

- » Whakaakona ō tamariki kia haumarū ai i runga i ngā rori, i ngā ara hīkoi anō hoki. Whakaatuhia atu ko hea e haumarū ana hei wāhi hīkoi mō rātou, me pēhea hoki e haumarū ai te whakawhiti rori.
- » Whakaatuhia ki ō tamariki te ara haumarū katoa ki te kura, ki ngā toa, ki te papa tākaro, ki ērā atu wāhi rānei he rite tonu tā rātou toro atu.
- » Mēnā e 5, iti iho rānei ngā tau o ō tamariki, me hīkoi tahi ki a rātou ki te kura, ki te kura kōhungahunga rānei.

Me āta tiro tiro mō ngā tamariki ka whakamuri ana tō kuhu, tō puta rānei i ngā ara urunga, i ngā whare karāti rānei.

He mōhiohio mō te hunga eke pahikara

Mēnā he kaieke pahikara, he mea nui tō hāngai ki ngā tikanga rori, ki ngā aratohu anō hoki, tae atu ki ērā e mea ana:

- » kia mau pōtae māro kōrua ko tō pāhihi piriana
- » kia kaha ngā whakatumu o tō pahikara, kia whai whakaata rama i muri anō hoki
- » kia whai rama tō pahikara i mua, i muri hoki, ka eke pahikara ana koe i te pō.

E toro ki nzta.govt.nz/roadcode/code-for-cycling mō ētahi mōhiohio anō, me ētahi kupu āwhina e haumarū ake ai tō eke pahikara.

He mōhiohio mō te hunga eke hōiho

He mea nui tā te kaieke hōiho whai i ngā tikanga rori i te whārangi nei. Mā reira e haumaruru ake ai te eke hōiho i te rori.

Ngā tikanga whakahaumaruru i te kaieke hōiho

- » Me rite tonu tō mau pōtae mārō ka tika ka eke hōiho ana. Ki te kore, ka whara pea tō māhunga ina taka koe i tō hōiho.
- » Me haere tō hōiho mā te taha mauī o te rori, ka mutu, kia kaha te piri hoki ki te taha mauī ka taea ana.
- » Kia mau ki te taha o te rori ka taea ana, engari kaua e takahia ngā ara hīkoi, ngā pātītī, ngā mōra rānei.
- » Kaua e nui atu i te takirua ina upane ana te haere.
- » Kaua e haere i te taha matau o tētahi waka e koke ana.
- » Mēnā koe e tātaki ana i tētahi anō kararehe i a koe e eke hōiho ana, kia mau ki te taha mauī, kia tawhiti ai i te rere o ngā waka.
- » Mēnā koe e eke hōiho ana, e tātaki ana rānei i te kararehe i te pō, me mau kākahu kōrekoreko, me kawē rama anō hoki.

Ngā waka ka tōia e te hōiho

- » I te pō, ko ngā waka ka tōia e te hōiho me whai rama mā i te taha whakatematau o mua o te waka, o te utanga rānei, me tētahi rama whero anō hoki i muri e muramura ana. Me kaua e whai i te rama whero i mua, i te rama mā rānei i muri i te waka i te pō.

He mōhiohio mō te kaihautū i te waka ahuhenua

Ko te kātū raihana ka hiahiaitia e āhei ai tō hautū i tētahi waka ahuhenua ka hāngai ki te momo, ki te taumaha, me te tere o taua waka.

E toro ki nzta.govt.nz/driver-licence-agricultural mō ētahi mōhiohio anō.

He mōhiohio mō te hunga eke kutariki

Ko te kutariki, ko tētahi waka e whai pūkaha ana, atu i te pahikara hikohiko, ā, e pēnei ana:

- » e rua, e toru rānei ōna wīra
- » ko tana tere mōrahi kāore e nui atu i te 50 kiromita i te hāora
- » ā,
 - › kāore rānei e nui atu i te 50cc te kītanga o te rango pūkaha
 - › he momo mātāpuna whakakaha kē atu rānei tōna, ehara i te pūkaha kōkeke.

He whai raihana ana tō eke kutariki mēnā nō te kātū 6 tō raihana motupaika, mēnā rānei nō te kātū 1 tō raihana waka. Mēnā he raihana ako tōu mō te kātū 1, mō te kātū 6 rānei, me whakaatu tō pereti L. Mēnā he raihana ako, he raihana here rānei tōu, me kaua koe e eke kutariki i waenga i te 10 karaka i te pō me te 5 karaka i te ata, me kaua hoki e kawē pāhihi.

Ngā tikanga whakahaumarū i te hunga eke kutariki

- » Me kaua koe e eke kutariki i runga i te ara hīkoi, i te ara pahikara rānei. Hāunga i tēnei ko ngā wā e whakaaetia e tētahi mana whakahaere i te rori kia whakamahia te ara hīkoi e te kaieke i te kutariki, i te motupaika rānei e tohatoha ana i te niupepa, i te reta, i tānga kē atu rānei ki ngā pouaka reta.
- » Me mau e koe, e ō pāhihi katoa hoki he pōtae mārō motupaika e whakaaetia ana ka eke kutariki ana.
- » I te pūtahi, me:
 - › whai rānei i ngā ture mō te waka
 - › me makere rānei i te kutariki, ka whakawhiti atu mā raro.
- » Ka āhei te rere piritaha me tētahi anō kaieke i te kutariki, me te pahikara rānei, engari kua ko tētahi momo waka kē atu.
- » Me takitahi te rere ka tohipa ana koe i waka kē atu.
- » Me kua te kutariki e tōia e tētahi anō waka.
- » Ka āhei tā te kutariki tō i te taupua, engari kāore e āhei te whakapiri ama.
- » Me kua koe e kawē pāhihi mā runga kutariki, me te kore o te nōhanga piriana, o ngā taunga waewae anō hoki. Mēnā he tamaiti tō pāhihi, me whakahaumarū te nōhanga piriana i ō te tamaiti waewae i ngā wīra.

- » Me kua koe e whakatū i tō kutariki ki te ara hīkoi.
- » Me whakakā e koe te ramaihu o tō kutariki i ngā hāora o te pōuri, arā i te 30 mēneti i muri i te tōnga o te rā, ki te 30 mēneti i mua i te atatū, me ngā wā kāore e mārama tō kite i te tangata, i te waka rānei ka 100 mita te tawhiti i a koe.
- » Me whakakā hoki te ramaihu o tō kutariki, ōna rama rere ao rānei i ngā hāora o te whitinga rā mēnā he mea waihanga tō kutariki nō te 1 o Hānuere, i te tau 1980, nō muri rānei i tērā.

Ngā āhuatanga me mātua whai tō kutariki

Ko tō kutariki me mātua whai:

- » tētahi rama whero i muri ka kitea tonuhia ina 100 mita te tawhiti
- » tētahi ramaihu toari e mārama ai tō kite i ngā mea katoa i te 30 mita i mua a koe
- » he hāona
- » he taea, e mārama ana te tapore
- » he pūnaha pai mō te whakaputa haupara kāore i te hoihoi rawa
- » he whakaurungi e haumarua ana
- » he kaupare pōharu
- » he whakatumu pai, i mua, i muri hoki
- » kia kotahi, kia rua rānei ngā rama tumu whero i muri – mēnā nō muri mai i te 1 o Hānuere, i te tau 1991 tana rēhitatanga tuatahi i Aotearoa
- » he whakaataata whero i muri.



Kia aronuitia

Ko ō utanga katoa ka kawea e koe mā runga i tō kutariki me mārō te herea, me kua hoki e pā ki te papa.

He mōhiohio mō te hunga eke i te taumatua neneke, i ngā taputapu runaruna rānei e whai wīra ana

E kapi ana i te taumatua neneke ko te tūru wīra e whai pūkaha ana, me ērā tūmomo taputapu. E kapi ana i ngā taputapu runaruna e whai wīra ana, ko te papa wīra, ko te kutapana, me ngā kutahiko e hāngai ana ngā āhuatanga ki ērā i raro iho nei.

Ko te taumatua neneke, he waka:

- » kua hoahoatia, ka waihangatia hoki, kāore e panonihia, hei whakamahi mā te hunga me whai tautoko neneke i runga i te pāngia o rātou e te hauātanga ā-tinana, ā-roro rānei
- » ka rere mā tētahi pūkaha anake, kāore e nui atu tana whakaputanga hiko i te 1500W
- » kua whakapuakitia e Waka Kotahi hei taumatua neneke e ai ki te wāhanga 168A (1) o te Land Transport Act, 1998.

Ko te taputapu runaruna e whai wīra ana:

- » he waka kawē e whai wīra ana, hāunga i te pahikara e nui atu ana tana whitianga wīra i te 355mm, he mea pana e te tangata, e te tō ā-papa rānei
- » e kapi ana ko tētahi waka kawē e whai pūkaha kōpana ana, kāore e nui atu i te 300W te tapeketanga whakaputanga kaha.

Ngā tikanga whakahaumarū i te hunga eke i te taumatua neneke me te taputapu runaruna e whai wīra ana

- » Ka rere ana i te ara, kia tūpato, kia whai whakaaro hoki ki tangata kē e whakamahi ana i taua ara.
- » Kia kaua e mōrearea te tere o tō haere mō tangata kē e whakamahi ana i taua ara.
- » Ka whakamahi ana koe i te ara hīkoi, me whai ko ngā ture e hāngai ana ki te waehīkoi i ngā rama pūtahi.
- » Me whakamahi ko te taumatua neneke, ko te taputapu runaruna e whai wīra ana ki te ara hīkoi mēnā rā ka taea. Mēnā me rere i te rori, me piri ki tōna tapa.
- » Ka rere ana mā te ara hīkoi, me tautuku koe ki te waehīkoi me ngā kaieke taumatua neneke.

**He pātai nō te
whakamātautau
raihana ako**



Te puka tātaki ki te whakamātautau raihana ako

Ngā pātai whānui

Hei āwhina i a koe ki te ako i ngā tikanga hautū, kei te wāhanga nei te nuinga o ngā pātai ka whiua pea ki a koe ki te whakamātautau ariā, me te nuinga o ngā pātai motuhake e hāngai ana ki te whai i te raihana ako, kātū 1.

Whakamahia ēnei pātai hei whakangungu i a koe anō, hei pātai atu rānei mā tētahi hoa, mā tētahi whanaunga rānei ki a koe.

Kia mōhio mai: ka whakahouhia ngā pātai whakamātautau i ōna wā. Ko ngā pātai hou mō te whakamātautau ka hāngai ki ngā mōhiohio i te puka tikanga hautū o te wā, ā, e whakairihia ana ki te pae tukutuku mō ngā tikanga hautū, ki nzta.govt.nz/road-code-updates

He mea tango ngā pātai ka pātaihia ki te whakamātautau ariā i te puka tikanga hautū. Nō reira, me mōhio koe ki ngā kōrero katoa o te puka tikanga hautū.

Hei whakaū i te tika o ō whakautu, tirohia te whārangi kua tohua i te rārangi whakautu.

E toro ki drive.govt.nz/roadcode ki te whakangungu tonu i a koe, ki te tākaro rānei i ngā kēmu me ngā panga hei āwhina i a koe ki te maumahara ki ngā tikanga hautū.

Ngā pātai matua (M)

- M1** Me mātua whakakā e koe ō rama ihuwaka ina pātata iho te tepenga o tō tirohanga i te:
 mita. wh99
- M2** Kia kua e roa ake i te hēkena tētahi waka e whakaputa ana i te auahi e kitea ana. wh136
- M3** Ko ēhea ngā rama o tō waka me kā rawa mēnā koe e hautū waka ana i te kohu?
 wh98
- M4** Kia hia, neke atu rānei, te roa o te rori ME wātea tonu i mua i a koe ka mutu ana tō tohipa i waka kē atu?
 mita. wh57
- M5** Ki te whara tētahi i tētahi tuinga waka, me wawe tā te kaihautū whakamōhio atu i tētahi pirihihana, ā, me pērā i roto i te:
 hāora. wh143
- M6** Me aha koe kia kua rā e whakamatapōhia e ngā rama ihuwaka o tētahi waka e ahu atu ana ki a koe?
 wh100
- M7** Me mātua whakaū koe he wāhi e wātea ana ki tō waka ki tāwāhi o te rārangi i mua i tō whakawhiti atu i te whakawhitinga ara tereina.
Kei te tika Kei te hē wh86

M8 Me mātua aha koe ka rongoa ana i te tangi ohotata, ka kite ana rānei i ngā rama whero e raparapa ana i te waka tūrora, i te waka patuahi rānei?

wh43

M9 Kei te whanga koe ki tētahi whakawhitinga ara tereina, ā, ka raparapa tonu ngā rama whero i muri i tā te tereina hipa atu. Me aha koe?

wh85

M10 E pā ana ki te ture tautuku, me aro ki ngā tomokanga ki ngā tūranga waka tūmatanui ānō he:

wh69

M11 I a koe e hautū motokā ana i ngā wā e mākū ai, e hauhunga ai rānei te huarere, he aha te tikanga me whai e koe hei whakaū i te tawhiti whaiwhai e haumarua ana?

wh56

M12 Hei aha te tikanga 2-hēkena?

wh55

M13 Me aha rawa koe, ka whakatata atu ana ki tētahi whakawhitinga waehīkoi, kāore ōna motu koutu?

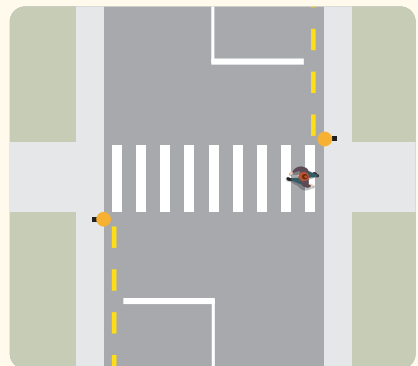

wh161

M14 Me aha rawa koe, ka whakatata atu ana ki tētahi whakawhitinga waehīkoi, he motu koutu tōna i waenganui?

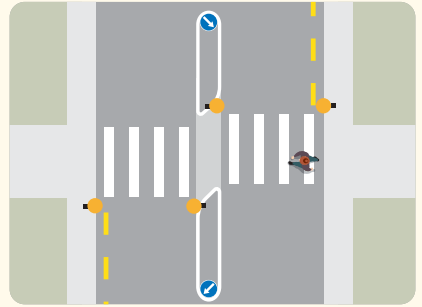

wh161

M15 Ka hautū waka ana koe ki tētahi rori whai ara, me āhei tō tū i roto i te haurua o te rori e kite ana koe e wātea ana i mua i a koe.

Kei te tika Kei te hē

wh122

M16 Āhea e tika ana kia ū ki te tikanga 4-hēkena?

wh56

M17 Me aha koe ka whakatata haere ana ki tētahi arawhiti ara-kotahi?

wh87

M18 Āhea e āhei ai tō tohipa i waka kē atu?

wh57

M19 He aha e kapi ana i te tikanga ā-ture o te 'rori'?

wh39

M20 Mātāmua ana ngā tohutohu a te pirihihana i ngā rama pūtahi, i ngā tohu rori, me ngā tikanga tautuku ki te pūtahi rori.

Kei te tika Kei te hē

wh44

M21 E huri whakatematau ana koe ki ngā rama pūtahi, ā, e kā ana te pere whero e aro whakatematau ana. Me aha koe?

wh78

M22 He aha te tikanga mēnā he rama kōwhai e raparapa ana i ngā rama pūtahi?

wh77

M23 I te pō, ME MĀTUA kimo ō rama ihuwaka ina:

wh99

M24 Ko te hia te paetere mō ngā waka e tohipa ana i tētahi pahi kura kua tū ki te tuku i ngā tamariki kia eke rānei, kia heke rānei i te pahi?

kiromita i te hāora

wh126

M25 Me mātua aha rā koe ina hiahia koe ki te huri whakatematau ki ngā rama pūtahi e kā ana te rama kākāriki?

wh77

M26 Ko te hia te paetere i te wāhi ka tohipa koe i te tohu ACCIDENT, tae noa ki tō tohipa atu i te wāhi o te tuinga?

kiromita i te hāora

wh126

M27 Ka tatū haere ana koe ki te pūtahi porotaka, me mātua tautuku koe ki ngā waka katoa ka whakawhiti i tō ara i tō taha mauī.

Kei te tika Kei te hē

wh81

M28 Ka hautū waka ana koe i te pō, ko ēhea ngā rama o tō waka me kā rawa?

wh99

M29 Āhea e āhei ai tō tohipa i waka kē atu mā te taha mauī i tētahi pūtahi, mēnā ka haumaru te pērā?

wh64

M30 He aha te tikanga o 'te paetere'?

wh124

M31 Mēnā koe e huri whakatemaui ana ki tētahi pūtahi, me mātua tautuku koe ki ngā waka e ahu ana ki a koe, otirā e huri whakatematau ana.

Kei te tika Kei te hē

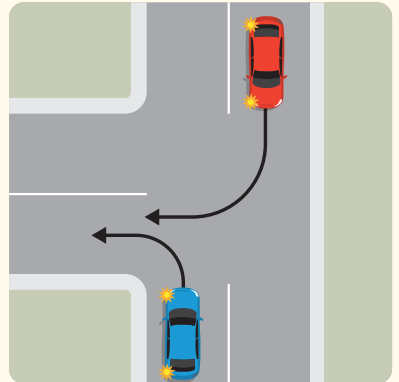

wh70

M32 Mēnā koe e haere tōtika ana ki tētahi pūtahi porotaka, kaua koe e tūtohu i a koe e whakatata atu ana ki te pūtahi porotaka, me tūtohu whakatemaui anake koe i a koe e hipa atu ana i te putanga i mua i tērā e hiahia ana e koe.

Kei te tika Kei te hē

wh83

M33 Mēnā e tamariki iho ana koe i te 20 tau te pakeke, ko te tepenga waipiro ā-ture, ko te kore tonu. He aha te tikanga o tēnei?

wh128

M34 Me aha rawa koe ka kite ana i ngā rama, he kikorangi me te whero ngā tae, e raparapa ana i muri i a koe?

wh43

M35 Me aha rawa koe ka raparapa ana ngā rama whero ki tētahi whakawhitinga ara tereina?

wh85

M36 Āhea rawa e tika ana kia tūtohu koe i tō huri whakatematau?

wh41

M37 Āhea rawa e tika ana kia whakakāngia e koe ō rama ihuwaka?

wh99

Ngā pātai mō te whakatū waka (WW)

WW1 Ko te hia te tata rawa ki tētahi urunga waka e whakaaetia ana te whakatū i tō waka?

mita

wh90

WW2 Āhea e āhei ai tō whakatū waka ki tētahi wāhi ka kīia he 'Loading Zone'?

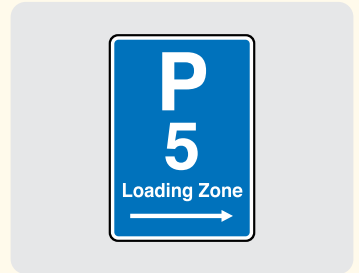

wh93

WW3 Ka whakatū waka ana koe ki tētahi rori e tūpoupou ana, me aha koe, e ai ki te puka tikanga hautū?

wh89

WW4 Āhea e āhei ai tō whakatū i tō waka ki runga i te pūhono wai patuahi?

wh90

WW5 Ko te hia te tata rawa e whakaaetia ana tō whakatū i tō waka ki te taha urunga o te whakawhitinga waehīkoi, mēnā karekau he rārangi kōwhai nakunaku i te rori?

mita

wh90

WW6 Ko te hia te tata rawa ki te pūtahi e whakaaetia ana tō whakatū i tō waka, mēnā karekau he rārangi kōwhai nakunaku i te rori?

mita

wh90

WW7 He aha te tikanga o tēnei tohu?



wh94

WW8 E āhei ana rānei te whakatū waka tūmataiti ki tētahi tūnga pahi?

wh90

WW9 He aha te tikanga o tēnei tohu?



wh92

WW10 E āhei ana tō whakatū i tō waka ki runga i te pūhono wai patuahi, ki te noho tonu tētahi tangata i roto i te waka e āhei ana te hūnuku atu i te waka.

Kei te tika

Kei te hē

wh90

WW11 KAUA RAWA koe e whakatū i tō waka ki te taha matau o te rori, hāunga i ngā wā:

wh90

WW12 He aha te tikanga o tēnei tohu?



wh93

Ngā pātai mō ngā take ohotata (O)

O1 Kei te hautū waka koe i tuawhenua i te pō, mea rawa ake ka weto ō rama ihuwaka. Me aha, e haumarua ai koe?

wh120

O2 Ki te tūtuki te waka e hautū nei koe, he aha hei mahi TUATAHI māu?

wh143

O3 Mēnā ko koe te kaihautū, ā, kua whara tētahi i te tuinga waka, me mātua whakamōhio koe i a wai?

wh143

O4 Āhea me whakakā ō rama mōreareatanga?

wh42

O5 Me aha koe ki te hiamoe haere koe i a koe e hautū waka ana?

wh131

O6 Āhea me mātua neke tō waka ki te taha, ka tuku ai i te waka tūroro, i te waka patuahi rānei ki te tohipa atu i a koe?

wh43

O7 He aha te tikanga o tētahi tapatoru whakaataata kua meatia atu ki te taha o te rori?

wh143

O8 E tohipa ana koe i tētahi rārangi o ngā waka kua whakatūria.
Ka kite koe i tētahi pōro e tupana haere ana ki te rori i mua i a koe.
Me aha koe?

wh107

O9 Me mātua aha koe ki te taka atu he karaihe i tō waka ki te rori?

wh137

O10 Me aha koe ina whakatata haere te waka tūroro ki muri i a koe, e raparapa ana ōna rama whero, e whakatangi ana rānei i tana tukuoro whakatūpato?

wh43

Ngā pātai mō ngā tohu me ngā tānga (T)

- T1** Kei te hautū waka koe i tētahi wāhi ko te 100km/h te paetere, ā, ka kitea tētahi tohu 'ACCIDENT'. Me whakapōturi kia hia km/h te tere mōrahi o tō haere?

kiromita i te hāora

wh126

- T2** Ko te tohu paetere 100 e mea ana kia kaua e pōturi iho i te 100km/h te tere o tō haere i ngā āhuatanga pai.

Kei te tika Kei te hē



wh124

- T3** Ko te tohu nei e mea ana kia 35km/h te tere, e haumaruru ai, e hāneanea ai hoki tō hautū waka i te pikonga ara.

Kei te tika Kei te hē



wh127

- T4** Kei te ara mauī koe i ngā rama pūtahi. E whanga ana koe ki te huri whakatemauī. Ko tēhea o ēnei tohu e tuku ana i a koe kia koke?

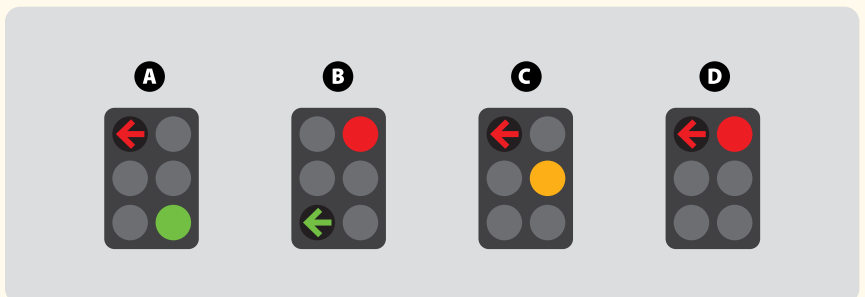

A B C D

wh79

T5 Ko te hia km/h te tere mōrahi e tika ana, ka tohipa ana koe i tētahi pahi e whakaatu ana i te tohu 'SCHOOL', kua tū ki te tuku i ngā tamariki kia eke, kia heke rānei?

kiromita i te hāora

wh126

T6 Ko te rārangi kōwhai nakunaku e tata ana ki te tapa o te rori e tohu ana ka āhei tō tū, tō whakatū rānei i tō waka ki reira, ahakoa āhea.

Kei te tika

Kei te hē

wh90

T7 He aha te tikanga o te tohu nei, ka whakatata haere ana koe ki tētahi arawhiti ara-kotahi?



wh87

T8 E whakatata haere ana koe ki tētahi whakawhitinga tūtei ā-kura, ā, kei te torona ake ngā tohu e rua. Āhea e āhei ai tō koke?

wh162

T9 Ka whakatata haere ana ki tētahi tohu tū, me tū koe ki hea?

wh71

T10 He aha te tikanga o tēnei rama pūtahi?



wh77

T11 He aha te tikanga o tēnei tohu?

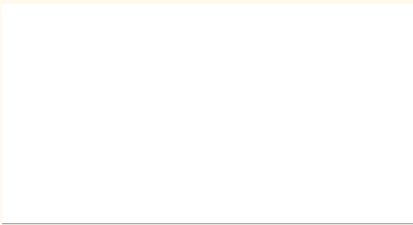

wh85

T12 He aha te tikanga o tēnei tohu?

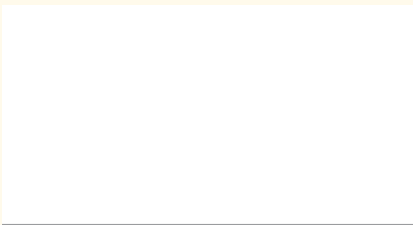

wh143

T13 Hei tā tēnei tohu e whakatata haere ana koe ki tētahi whakawhitinga ara tereina. Me aha koe?



wh85

T14 He aha te tikanga o tēnei tohu?

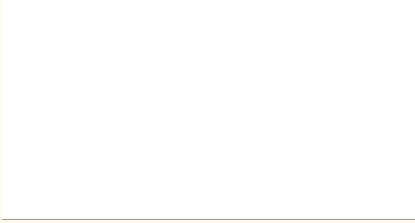

wh124

T15 He aha te tikanga o tēnei tohu?

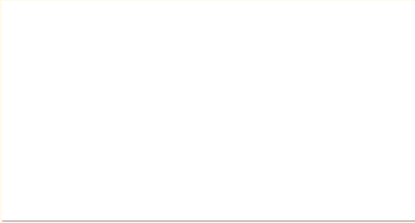

wh32

T16 He aha te tikanga o tēnei tohu?

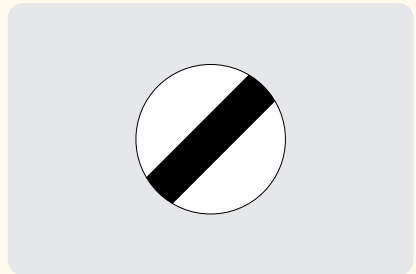
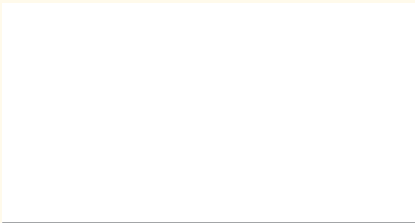

wh124

T17 He aha te tikanga o tēnei tohu?



wh124

T18 He aha te tikanga o te T2 i te tohu Transit Lane?

wh30

T19 He aha te tikanga o tēnei tohu?



wh32

T20 Me aha rawa koe i tētahi pūtahi e whakahaerehia ana e te tohu tū?

wh71

T21 Me aha rawa koe i tētahi pūtahi e whakahaerehia ana e te tohu tautuku?

wh72

T22 He aha te tikanga o tētahi whakaata rama (karu ngeru) i te rori, he kikorangi te tae?

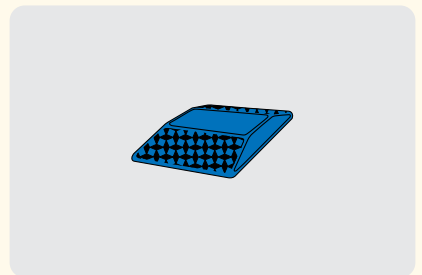

wh101

T23 He aha te tikanga o tētahi rārangi kōwhai nakunaku i te rori e pātata ana ki te taparori?

wh90

T24 E āhei ana tō whakamahi i te taiwhanga huri whakatematau hei tohipa i tētahi anō waka e haere tōtika ana.

Kei te tika

Kei te hē

wh49

T25 Āhea āhei ai te whakamahia o te awarua wawaenga?

wh50

T26 He aha te tikanga o ēnei tānga rori?

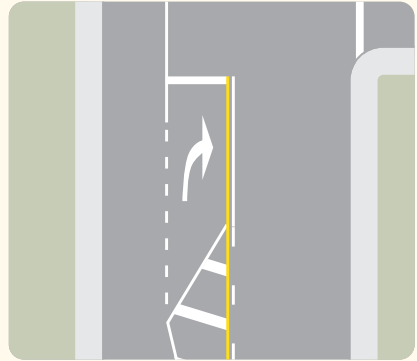

wh49

T27 He aha te tikanga o te taimana mā ka peitahia ki te rori?

wh161

T28 He aha te tikanga o tēnei tānga rori?



wh91

T29 Kei te hautū waka koe i tētahi rori whai ara, ā, kei tō ara tētahi pere e tohu ana i te huri whakatemalaī anake. Me aha rawa koe?

wh51

T30 He aha te tikanga o tētahi whakaata rama (karu ngeru) i te rori, he mā te tae?

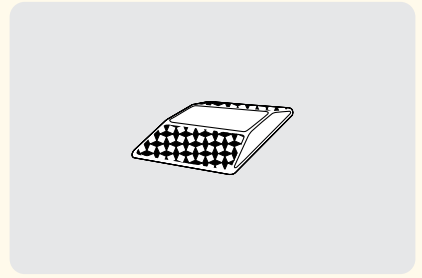

wh101

T31 He aha te tikanga o tētahi whakaata rama (karu ngeru) i te rori, he kōwhai te tae?

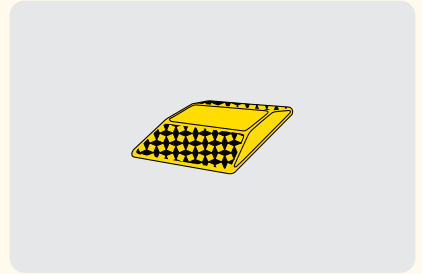

wh101

T32 He aha te tikanga mēnā e raparapa ana ngā rama pūtahi kōwhai?

wh77

T33 Kei te whakatata haere koe ki tētahi arawhiti ara-kotahi, ā, ka kite koe i te tohu nei. Me aha rawa koe?



wh87

T34 He aha te taka e āhei ai tā tētahi waka whakamahi i te awarua wawaenga?

wh50

T35 Me aha rawa koe ka whakatata haere ana ki tētahi rama pūtahi e kā ana te rama whero?

wh77

T36 Me aha rawa koe ka kite ana koe i ngā rama whero e rua e raparapa ana i waho i te teihana patuahi?

wh44

T37 He aha te tikanga o tēnei tohu?

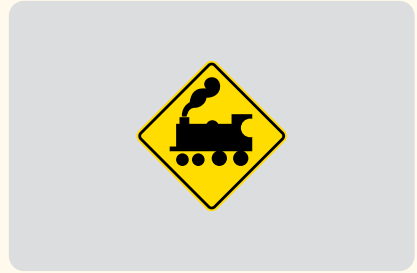

wh85

T38 He aha te mahi ka āhei ki ngā rama pūtahi mēnā e kā ngātahi ana te rama whero me tētahi pere kākārīki e aro whakatematau ana?

wh80

Ngā pātai mō ngā tūnga i te rori (R)

R1 Ka hautū waka ana koe i tētahi rori ara-kore, ko hea te wāhi tika mō tō waka?

wh39

R2 Ka huri whakatemataua ana koe i tētahi rori ara-rua ki tētahi tiriti ahunga tahi e rua ōna ara, me huri koe ki tēhea o aua ara?

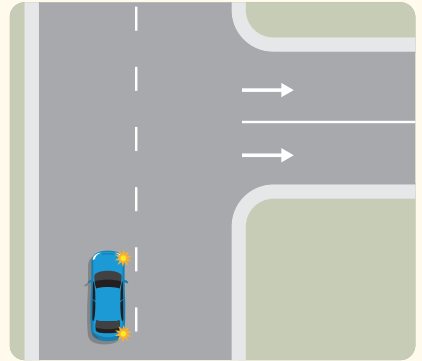

wh52

R3 Me mātua aha koe ina hiahia koe ki te whakawhiti i tō waka i te ara mataua ki te ara mauī?

wh53

R4 Me mātua aha koe ka huri whakatemataua ana ki tētahi pūtahi porotaka?

wh82

R5 Me mātua aha koe, ka huri whakatemauī ai ki tētahi urunga waka?

wh46

R6 Kei te hiahia koe ki te huri whakatemataua ki tētahi ara whāiti i tuawhenua. He waka kei te ahu pēnā atu ki a koe, he waka anō kei muri i a koe. He aha te kōwhiringa haumarua ake?

wh48

Ngā pātai whanonga (N)

N1 Ka hautū waka ana koe i te pō, e mārama taiahoaho ana ō rama ihuwaka, āhea rawa ME kimo e koe?

wh99

N2 Me aha koe ka tohipa ana i tētahi e eke hōiho ana?

wh169

N3 Mēnā me pōturi tō hautū waka, ā, ka whakapōrearea pea koe i waka kē atu, me aha koe?

wh123

N4 He aha ngā mahi KĀORE e whakaaetia i a koe e hautū waka ana i te huarahi matua?

wh67

N5 Me aha koe ina whakatata haere atu ana tētahi māpu hipi ki a koe i tētahi rori i tuawhenua?

wh137

N6 Ko te hia te tawhiti e tūtohua ana ka tohipa ana tō waka i tētahi kaieke pahikara?

mita

wh164

N7 Me aha koe mēnā koe e whai ana i tētahi waka i tētahi rori kirikiri e pūehuehu ana?

wh106

N8 Me aha koe ka hautū waka ana i te kohu?

wh98

N9 Kei te heke koe i tētahi puke mā tētahi ara whāiti e tūpoupou ana, ā, he waka anō e piki ana i taua puke. Me aha koe?

wh137

N10 ME MĀTUA kimo ō rama ihuwaka ina:

wh99

N11 Ko te aha te tikanga pai hei whai māu i ngā wā e kōmiti haere ana ngā waka i te rori?

wh65

N12 Me pēhea e tino haumaruru ai tō kawera i rō waka?

wh135

N13 Me KAUA rawa e whakatuwhera i te kūaha o tō waka ina:

wh136

N14 Ki te hipa atu koe i te putanga e hiahia ana i te huarahi matua, me:

wh67

N15 Mēnā koe e hautū waka ana, ā, e hiahia ana koe ki te whakamahi i tō waea, me aha koe?

wh138

N16 Me aha koe mēnā e hiahia ana te waka i muri i a koe ki te tohipa atu i a koe?

wh58

N17 Mā te waipiro e pōturi iho ai ō uruparetanga i a koe e hautū waka ana.

Kei te tika Kei te hē

wh128

N18 Ka wehe ana koe i te taparori, kia uru ai ki te rere o ngā waka, me aha koe, i tua atu i te tirotiro mēnā e haumaruru ana?

wh40

N19 I mua i tō whakawhiti ara ki tō taha mauī, me mātua tūtohu mō te 3 hēkena, roa atu rānei. He aha kē atu me mātua mahi e koe i reira?

wh53

N20 Me aha koe mēnā ka tata rawa te whaiwhai a waka kē atu i a koe?

wh112

N21 E hiahia ana koe kia puta tō waka i tētahi tūranga ki te kuhu ki te rere o ngā waka i te rori. Me mātua aha koe i mua i tō neke atu?

wh40

N22 Ka hautū waka ana koe ki ngā wāhi e kaha whitikina ana e te rā, me mau ō mōhiti rā, me whakamahi hoki ngā ārai rā o tō waka, e haumaruru ai koe. He aha atu ngā mahi e tūtohungia ana?

wh104

N23 Me aha koe mēnā ka tīmata te waka i muri i a koe ki te tohipa i a koe?

wh58

N24 Ka kite koe i te waehīkoi e kawe ana i tētahi tokotoko mā e whakawhiti ana i te rori. Me aha koe?

wh163

N25 E hiahia ana koe ki te huri whakatemaui ki te pūtahi. Me aha koe?

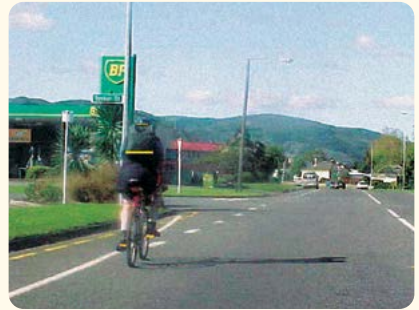

wh73

N26 Ka tirohia ō whakaata, ā, ka kitea he kaieke pahikara. Me aha koe i a koe e whakatuwhera ana i te kūaha o tō waka?

wh136

N27 Me pēhea e pai katoa ai tō tiro tiro mō ngā mōreareatanga i mua i tō neke whakamuri i tō waka?

wh68

N28 Ko koe te kaihautū o te waka kikorangi. O ngā mōreareatanga e whā kua tohungia i te hoahoa nei, ko tēhea te mea matua e nui katoa ana te tūpono ka mate koe ki te aro tōtika atu, ka mahi whawhati tata ai?

A B

C D

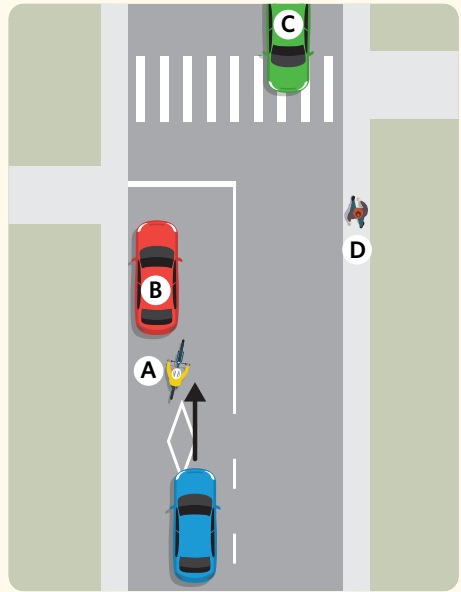

wh109

N29 Ko koe te kaihautū o te waka kikorangi. O ngā mōreareatanga e whā kua tohungia i te hoahoa nei, ko tēhea te mea matua e nui katoa ana te tūpono ka mate koe ki te aro tōtika atu, ka mahi whawhati tata ai?

A B

C D

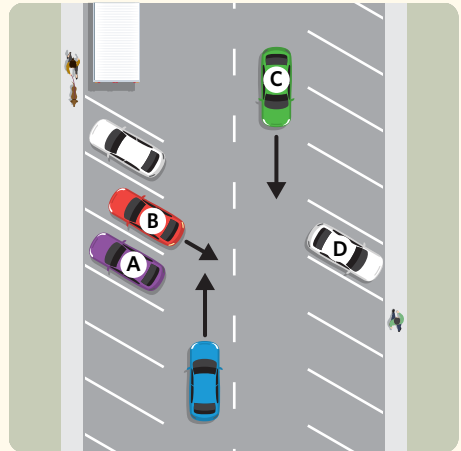

wh109

N30 Ko koe te kaihautū o te waka kikorangi. O ngā mōreareatanga e whā kua tohungia i te hoahoa nei, ko tēhea te mea matua e nui katoa ana te tūpono ka mate koe ki te aro tōtika atu, ka mahi whawhati tata ai?

A B

C D

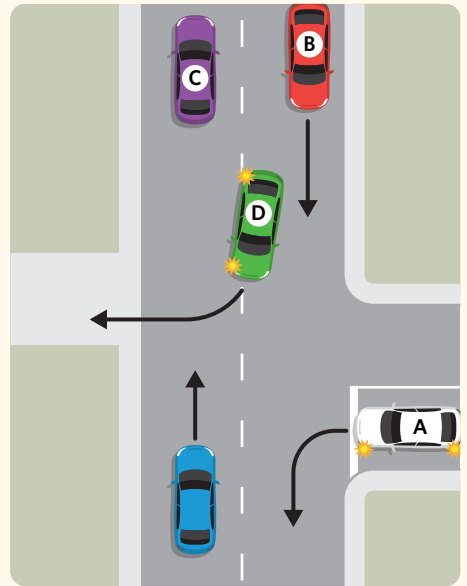

wh110

N31 Ko koe te kaihautū o te waka kikorangi. O ngā mōreareatanga e whā kua tohungia i te hoahoa nei, ko tēhea te mea matua e nui katoa ana te tūpono ka mate koe ki te aro tōtika atu, ka mahi whawhati tata ai?

A B

C D

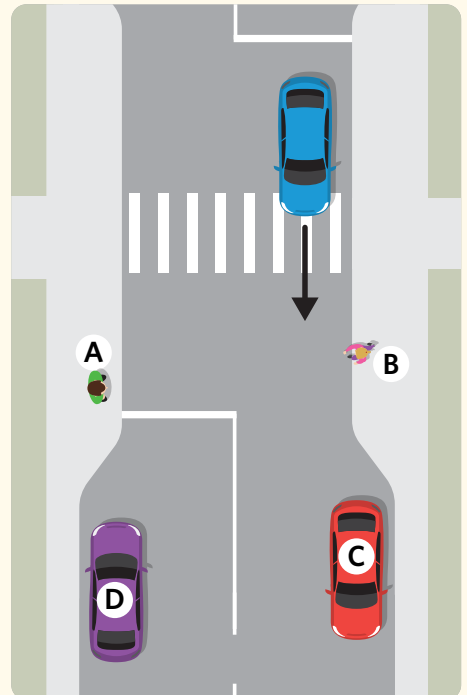

wh110

N32 Me aha koe, kia tino haumarua ai tō whakatata atu ki te pūtahi?

wh70

N33 Me aha koe i a koe e whai ana i tētahi anō waka i te wā e mākū ana te huarere?

wh97

N34 Me aha koe ina tūpono atu ki ngā kararehe e ahu pēnā atu ana ki a koe i te rori?

wh137

N35 Me aha koe ki te whakatata haere koe ki te rama pūtahi, ā, ka huri ngā rama i te kākāriki ki te kōwhai?

wh77

N36 Me mātua whakaū e koe he wāhi e wātea ana ki tō waka ki tērā atu taha o te whakawhitinga ara tereina i mua i tō whakawhiti atu.

Kei te tika Kei te hē

wh85

N37 E whakaaetia ana rānei tō hautū i tētahi waka me tētahi utanga kāore i te tika te herea?

wh135

Ngā pātai mō ngā pūtahi (P)

P1 Me mātua tautuku rānei te kaihautū o te waka kikorangi?

Āe Kāo

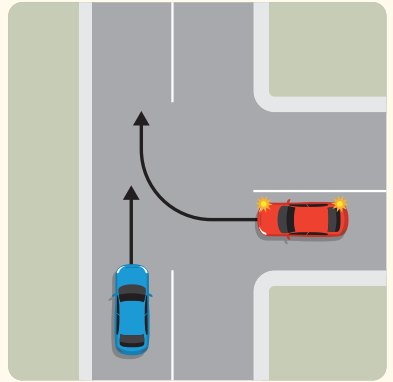

wh76

P2 Me mātua tautuku rānei te kaihautū o te waka kikorangi?

Āe Kāo

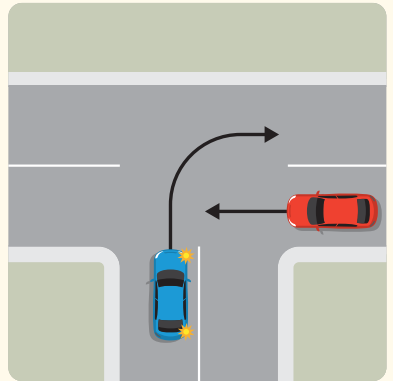

wh76

P13 Me mātua tautuku rānei te kaihautū o te waka kikorangi?

Āe Kāo

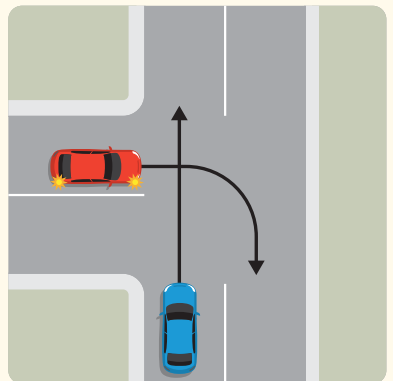

wh76

P4 Me mātua tautuku rānei te kaihautū o te waka kikorangi?

Āe Kāo

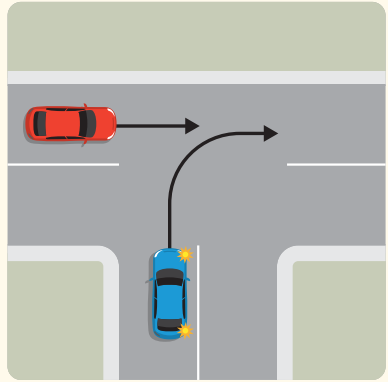

wh76

P5 Me mātua tautuku rānei te kaihautū o te waka kikorangi?

Āe Kāo

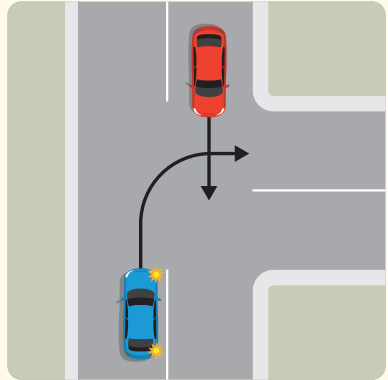

wh73

P6 Me mātua tautuku rānei te kaihautū o te waka kikorangi?

Āe Kāo

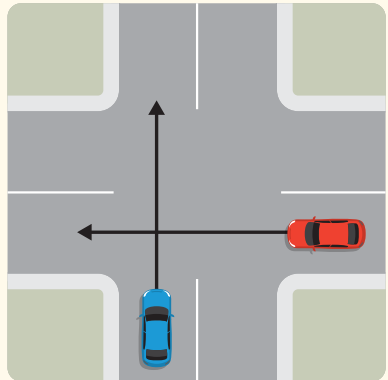

wh76

P7 Me mātua tautuku rānei te kaihautū o te waka kikorangi?

Āe Kāo

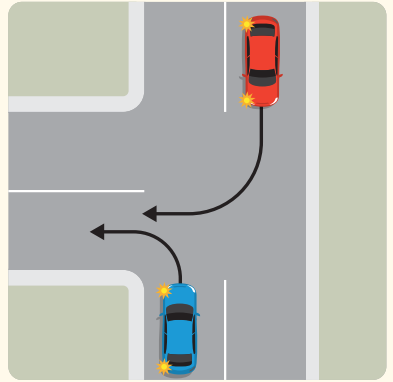

wh75

P8 Me mātua tautuku rānei te kaihautū o te waka kikorangi?

Āe Kāo

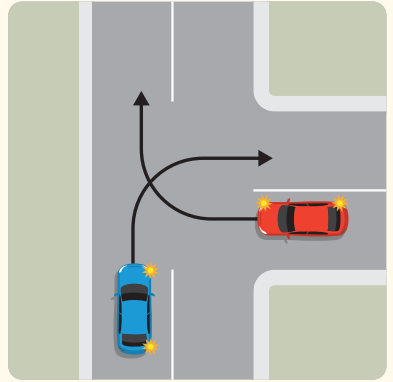

wh76

P9 Me mātua tautuku rānei te kaihautū o te waka kikorangi?

Āe Kāo

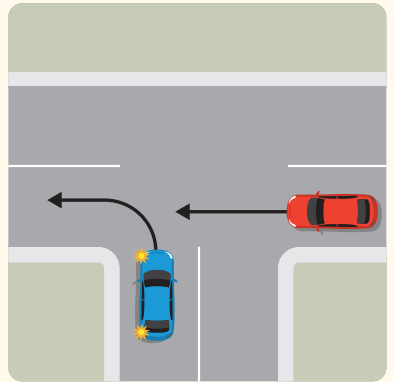

wh76

P10 Me mātua tautuku rānei te kaihautū o te waka kikorangi?

Āe Kāo

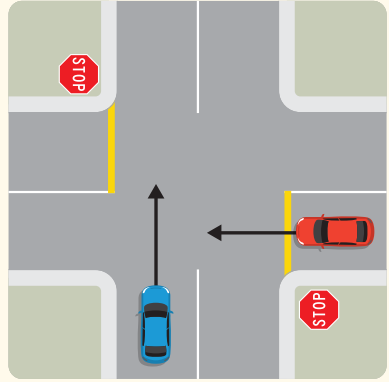

wh72

P11 Me mātua tautuku rānei te kaihautū o te waka kikorangi?

Āe Kāo

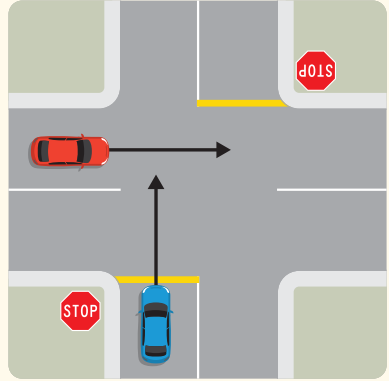

wh72

P12 Me mātua tautuku rānei te kaihautū o te waka kikorangi?

Āe Kāo

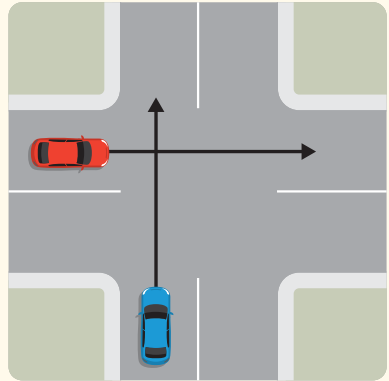

wh76

P13 Me mātua tautuku rānei te kaihautū o te waka kikorangi?

Āe Kāo

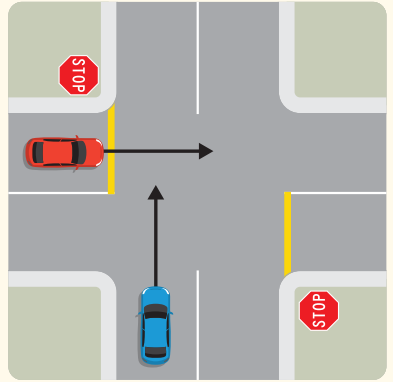

wh72

P14 Me mātua tautuku rānei te kaihautū o te waka kikorangi?

Āe Kāo

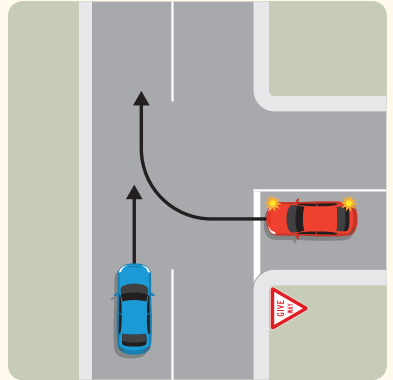

wh76

P15 Me mātua tautuku rānei te kaihautū o te waka kikorangi?

Āe Kāo

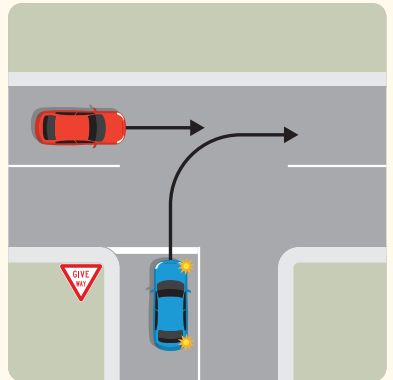

wh76

P16 Me mātua tautuku rānei te kaihautū o te waka kikorangi?

Āe Kāo

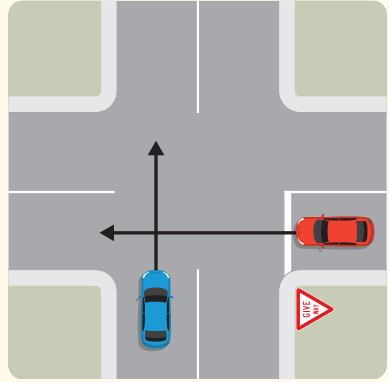

wh72

P17 Me mātua tautuku rānei te kaihautū o te waka kikorangi?

Āe Kāo

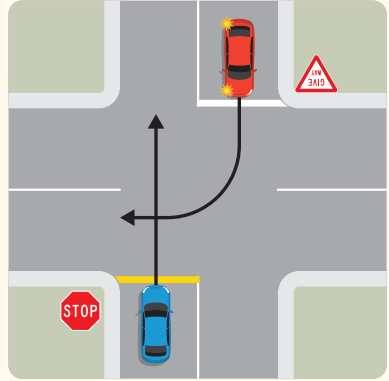

wh72

P18 Me mātua tautuku rānei te kaihautū o te waka kikorangi?

Āe Kāo

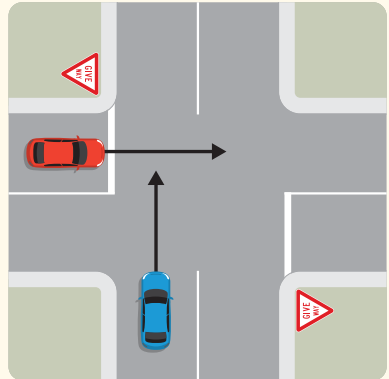

wh72

P19 Me mātua tautuku rānei te kaihautū o te waka kikorangi?

Āe Kāo

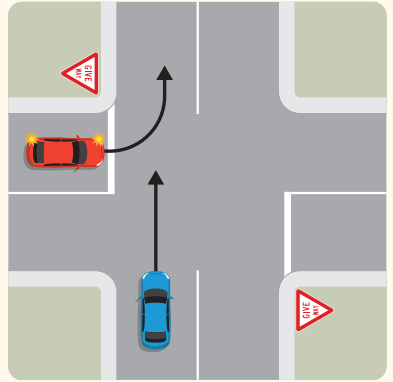

wh72

P20 Me mātua tautuku rānei te kaihautū o te waka kikorangi?

Āe Kāo

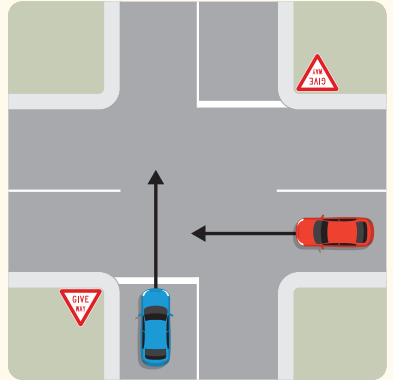

wh72

P21 Me mātua tautuku rānei te kaihautū o te waka kikorangi?

Āe Kāo

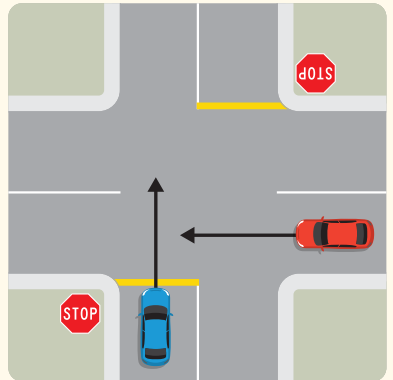

wh72

P22 Me mātua tautuku rānei te kaihautū o te waka kikorangi?

Āe Kāo

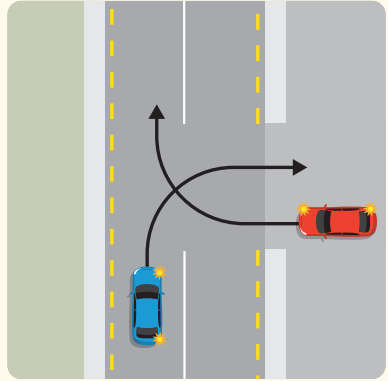

wh76

P23 Me mātua tautuku rānei te kaihautū o te waka kikorangi?

Āe Kāo

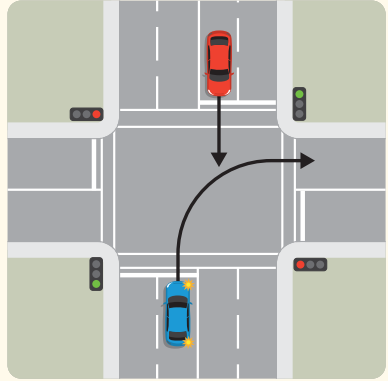

wh74

P24 Me mātua tautuku rānei te kaihautū o te waka kikorangi?

Āe Kāo

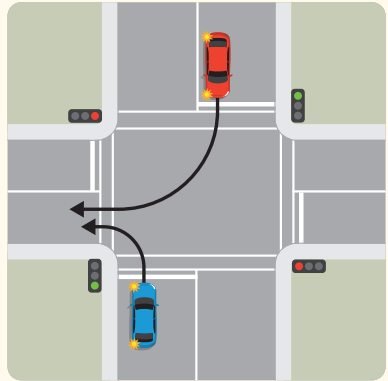

wh75

P25 Me mātua tautuku rānei te kaihautū o te waka kikorangi?

Āe Kāo

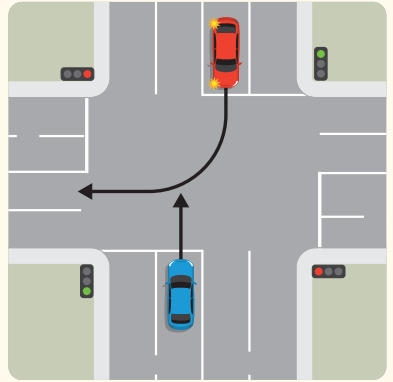

wh74

P26 Me mātua tautuku rānei te kaihautū o te waka kikorangi?

Āe Kāo

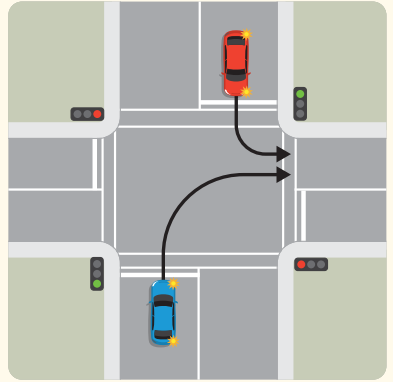

wh75

P27 Me mātua tautuku rānei te kaihautū o te waka kikorangi?

Āe Kāo

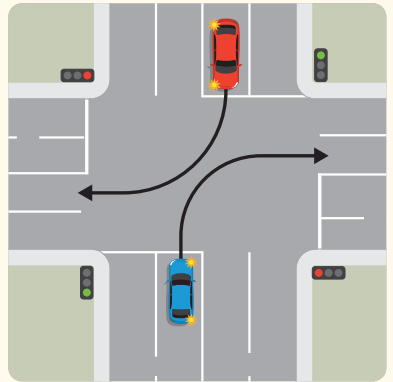

wh71

P28 Me mātua tautuku rānei te kaihautū o te waka kikorangi?

Āe Kāo

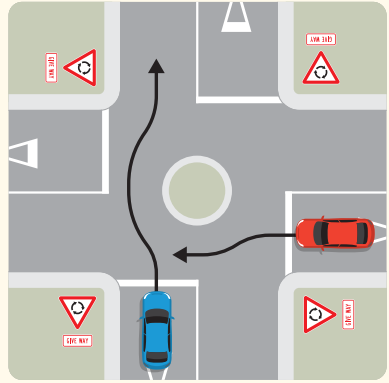

wh81

P29 Me mātua tautuku rānei te kaihautū o te waka kikorangi?

Āe Kāo

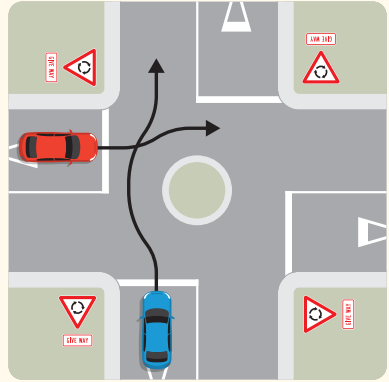

wh81

P30 Me mātua tautuku rānei te kaihautū o te waka kikorangi?

Āe Kāo

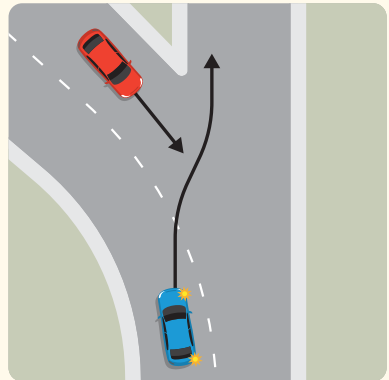

wh74

P31 Me mātua tautuku rānei te kaihautū o te waka kikorangi?

Āe Kāo

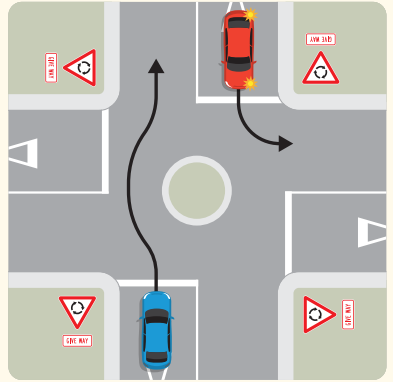

wh81

P32 Me mātua tautuku rānei te kaihautū o te waka kikorangi?

Āe Kāo

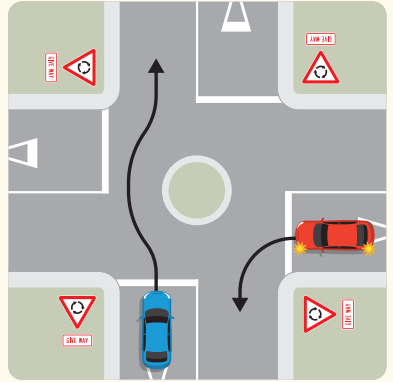

wh81

P33 Ko koe te kaihautū o te waka kikorangi. Me aha rawa koe?

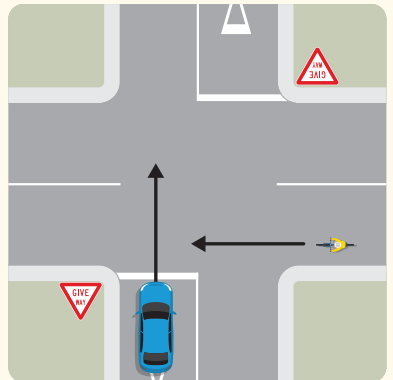

wh72

P34 Ko koe te kaihautū o te waka
kikorangi. Me aha rawa koe?

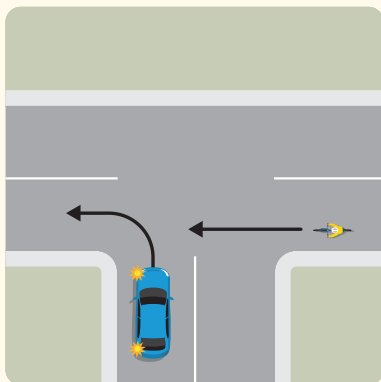
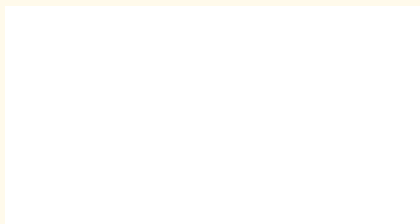

wh76

Ngā pātai motuhake mā te kaihautū motokā

- 1 Ko te hia te toronga roa katoa o tētahi utanga ka whakaaetia ki muri i te paewira o muri?

mita wh155
- 2 He tohu whakamana waka tō tōu waka, engari kua raru tētahi o ō rama tumu whero o muri. Me aha koe?

wh150
- 3 He aha tā te tohu whakamana waka e tohu nei?

wh150
- 4 Ko te hia te toronga roa katoa o tētahi utanga ka whakaaetia ki mua i te motokā?

mita wh155
- 5 Ko ēhea ngā wāhanga o te waka me kaha kia kaua rā ngā oro turituri me ngā hau kino e hou atu ki te waka?

wh136
- 6 I te pō, he aha me mau ki muri o tētahi waka e tōia ana?

wh154
- 7 Ko te hia te pāpaku katoa o te tapere taea e whakaaetia ana mō ngā taea motokā?

mitamano wh152

- 8 Ki te tō koe i tētahi anō waka, ko te hia te tawhiti rawa e whakaaetia ana i waenga i ngā waka e rua?
 mita wh156
- 9 He aha te mea me mātua whakaatu i muri o tētahi tauaru ka tōia ana i te pō?
 wh154
- 10 Me mātua aha koe i mua i te panonihia o te hanga o tō waka?
 wh153
- 11 Ka mana tō hautū kutariki i tō raihana motokā.
Kei te tika Kei te hē wh128
- 12 Ko te hia km/h te tere mōrahi o te haere ka whakaaetia e te ture mō te waka e tō ana i te tauaru i te rori tuwhera?
 kiromita i te hāora wh154
- 13 He raihana here tōu. Ko tētahi o ngā herenga mō te hautū waka i te pō me te kore o tētahi kaitiro tiro, kia KAUA rā koe e hautū waka i waenga i ēhea hāora?
 wh19
- 14 Ko te hia km/h te tere mōrahi o te haere ka whakaaetia mēnā e mau ana te waka i tētahi wīra taupua?
 kiromita i te hāora wh138

- 15** Mēnā he raihana here tōu, āhea e āhei ai tō kawē pāhihi?
 wh19
- 16** Mēnā he raihana ako tōu, ka āhei rānei tō kawē pāhihi?
 wh15
- 17** Mēnā he raihana ako tōu, me mātua hautū waka koe me te kaitirotiro i tō taha. He aha te kaitirotiro?
 wh19
- 18** Mēnā he raihana ako tōu, me kawē rawa rānei e koe ka hautū waka ana?
 wh8
- 19** Ko wai e noho haepapa ana ki te whakaū i te whakamahia o te tātua nōhanga, o te whakaita tamariki rānei i te waka e te tamariki kāore anō kia 15 tau te pakeke?
 wh141
- 20** Ka ahatia ina pahū tētahi o ō taea o mua?
 wh115
- 21** Ka ahatia ina pahū tētahi o ō taea o muri?
 wh115

22 Kua tuwhera poka noa te panati o tō waka i a koe e hautū ana, ā, tē taea e koe te kite atu. Me aha koe?

wh119

23 Me aha koe ina raru tō waka i tētahi huarahi matua?

wh142

24 E pakeke ake ana i te 15 tau ngā pāhihi i tō waka. Ko wai e noho haepapa ana ki te whakaū i tā rātou whakamau tātua nōhanga?

wh141

Kuputaka



Kuputaka

A

ara	lane
ara urunga	driveway
aupuru whakatumu	brake pad
awarua wawaenga	flush median

H

hāona	horn
hauroki	diagonal

K

kaitāwhai i te rori	road user
kakare	stirred up, turbulent
kāraho	deck
kimo	to dip headlights
kiri rori	road surface
kōmiti	to merge
kūkā	congestion
kūreureu	uneven
kutariki	moped
kūtere whakatumu	brake fluid
kumukumu	unpredictable

M

māniana	slippery
matika	hook
mōnehu	expired
mōrahi	maximum

N

nihowhiti	gear
-----------	------

P

pāhihi	passenger
parenga paheke	skid resistance
pēhanga	pressure
pere	arrow
perori	to swerve
pīngore	non-rigid, flexible
piriana	pillion
pou tauārai	barrier arms
pūnaha tumu waipēhi	hydraulic brake
pūnguru	worn, corroded
pūtahi	intersection
pūtahi porotaka	roundabout

R

rama hikuwaka	tail lights
rama ihuwaka	headlights
rama pūtahi	traffic light, traffic signals
rama tūtohu	indicators
rangitahi	temporary
rango	roller

T

taea	tyre
tahetoka	amber
taiwhakamaru	safety cushion
taparori	kerb
tārakerake	windscreen wiper
tātua nōhanga	seatbelt
tauaru	trailer
taumatua neneke	mobility device
tauri wīra	tracks
tautuku	to give way
tepenga	limit

tīemiemi	to move up and down
tīhara	diesel
tīrewa tuanui	roofrack
tohipa	to overtake, pass
tokorera	forklift
torehapehape	uneven, bumpy
toromaka	buckle
tumu	to brake
tūrākaha	overload
tūwhena	stable

W

waehīkoi	pedestrian
waka kōperu	van
waka paeuta	ute
waka tāwhai	all-terrain vehicle (ATV)
waka whakahara	oversize vehicle
wakapuni	motorhome
wīra taupua	space-saver wheel
wīra urungi	steering wheel

WH

whaitua huna	blindspot
whakaata aro whakamuri	rear-view mirror
whakaata rama (karu ngeru)	reflector (cat's eye)
whakaata tahataha	side mirror
whakaataata	reflective
whakahohoro	to accelerate
whakaita tamariki	child restraint
whakakopa	to clamp
whakapūahoaho	demister
whakarara	parallel
whakaroau	stationary, motionless
whakatū	to park
whakatumu	brakes

He whakamāramatanga kupu

Kupu	Tikanga
Āpiha whakaraihana	<p>Mō te nuinga o ngā ratonga whakaraihana kaihautū, me toro koe ki tētahi āpiha whakaraihana kaihautū. E toro ki nzta.govt.nz/agent hei kimi i tētahi āpiha i tō takiwā.</p> <p>Ko ā mātou āpiha, ko ētahi o ngā tari o:</p> <ul style="list-style-type: none"> » The Automobile Association (AA) aa.co.nz » Vehicle Testing New Zealand (VTNZ) vtnz.co.nz
Ara	<p>Ko tētahi wāhanga o te rori ka whakamahia e tētahi rārangi waka. Ko ngā tepenga mauī, matau hoki o te ara ka tohungia pea ki ngā rārangi ara, ki te rārangi wawaenga, ki te rārangi tapa, ki te tapa tonu rānei o te ara, ki te tapa rānei o te kiri pia o te rori, ki te puku rānei o te rori.</p>
GCW - te tōpūtanga taumaha	<p>Ko te tōpūtanga o te GLW o ngā waka e whakakotahitia ana hei waka wāhanga maha.</p>
GLW - te taumaha whai utanga	<p>Te taumaha ake o:</p> <ul style="list-style-type: none"> » tētahi taumahatanga e tohungia ana hei GLW mō te waka e tōna kaihanga » tētahi taumahatanga e tohungia ana hei GLW mō tētahi waka, mō tana momo rānei, e Waka Kotahi » te tōpūtanga o te taumaha o te waka me tana utanga, tae atu ki ngā taputapu me ngā āpitihanga.
Kaitāwhai i te rori	<p>Ko te kaihautū, ko te kaieke rānei i te waka whai pūkaha, i te pahikara rānei, ko te waehīkoi rānei.</p>
Kaitirotiro	<p>Ka hautū waka ana koe i raro i tō raihana ako, me haere tahi me tētahi kaitirotiro i tō taha i ngā wā katoa.</p> <p>Me pēnei ia:</p> <ul style="list-style-type: none"> » Me whai e ia tētahi raihana matua nō Aotearoa e mana tonu ana mō te kātū waka e ako nei koe ki te hautū, ā, » Me kua tana raihana nō Aotearoa e whai herenga, ā, » Me rua tau, nui atu rānei e mau ana tana raihana matua nō Aotearoa, tana raihana rānei nō tāwāhi e taurite ana te momo. » Me noho ki te tūru pāhihi i tō taha tonu i a koe e hautū waka ana » Me kawē tana raihana i tōna taha.

Kupu	Tikanga
Kōmiti	<ol style="list-style-type: none"> 1. Ko tētahi waka kotahi e uru ana ki te rere o ngā waka i te rori, hei whakatauirā ake, ko te wehenga atu o te waka i te taparori. 2. Ko te whakakotahitanga o ngā rerenga waka e rua, neke atu rānei, hei tauira, ko te piringa o ngā ara e rua hei ara kotahi.
Tauaru	E kapi ana i tēnei ko ngā waka puni, me ngā tauaru hei kawē i te poti, i te hōiho anō hoki.
Te taumaha i runga rori	Ko te tōpūtanga o te taumaha o te waka me tana utanga, ahakoa āhea.
Te whakaaetanga LAMS	<p>Ko tētahi motupaika ka whakaaetia i raro i te kaupapa ka tapaina ko te 'learner approved motorcycle scheme (LAMS)'.</p> <p>E toro ki nzta.govt.nz/lams mō ētahi mōhiohio anō.</p>
Tirohanga ā-māhunga	Ka tiro whakamuri te kaihautū ki tua i tōna pokohiwi mauī, matau rānei mā ngā matapihi i ngā tahataha o te waka, kua mā te matapihi o muri, kia kitea mēnā he kaitāwhai kē atu i te rori i ngā whaitua huna tē kitea mā ngā whakaata.
Waka motuhake	Ko te tokorera, ko ngā waka rānei ka rere mā te rango, mā te tauri wīra rānei. E kapi ana hoki i tēnei ko ngā waka whai pūkaha ka rere mā te wīra, engari ehara i te waka kawē pāhihi, i te waka ngaio, i te tarakihana, i te waka patuahi, i te waka kawē waka rānei.
Whakawhitinga waehīkoi	He wāhanga o te rori e peitahia ana ki ngā rārangi mā e whakarara ana, e tohungia ana hoki ki tētahi tohu whakawhitinga waehīkoi, e whai ana i ngā rama kōwhai e raparapa ana, kāore rānei.

Rārangi kuputohu



Rārangi kuputohu

A

akoranga kaihautū waka	113
āpiha whakaraihana kaihautū	13
ara motuhake	54
ara pahikara	45, 53, 90, 96, 164, 166, 174
ara tohipa	54
ara wātea motuhake	30
arawhiti ara-kotahi	87
aukati	95
awarua wawaenga	63

H

haepapa tangata rēhita	134-135
hāora mahi	139
hauata - tirohia ko tukinga waka	
hautū i te pō	99-101
hautū mōrearea	146, 169
hautū waka i te ara whānui	67
herenga kitenga karu	23
herenga kutariki	175
herenga tauaru (mō te rama)	156-157
herenga waka	150-152
hōiho i te rori	169
haere whakamuri	68
hoko waka	135, 148
huarere kino - te hautū waka	56, 97-98
huri	45-51
huri whakamuri	29, 50

K

kaiako hautū - tirohia hoki ko ngā kaitirotiro	16-17
kaieke kutariki	174-175
kaieke motupaika	168
kaieke pahikara	164-166, 172
kaihautū koroheke	25
kaihautū nō tāwāhi	25
kaihautū pōturi	123
kaitirotiro - tirohia hoki ko ngā kaiako hautū	15, 19, 227
kāpō hihirā	104
kararehe	137, 173
kiri rori	105-106
kōmiti	65-66
kōpiko	59, 105, 107
kūaha - te whakatuwhera me te kati	61, 136, 152, 164

M

mahere kaupare mōreareatanga	107
mahinga rori	102-103
matea reo, kōrero ā-waha rānei	14-15
mōkai	136, 139
mōreareatanga	55, 104-107
mūhoretanga waka	142

N

noho whakawhara i te waka	135
---------------------------	-----

O

ōta aukati raihana hautū (driver license stop order DLSO)	147
---	-----

rere auheke	137
rere aupiki	137
rori ara kore	39, 46
ruha kaihautū	130-131

T

taiwhanga huri	49
take ohotata - tirohia hoki ko ngā tuinga waka	107, 114
› ahi waka	117
› matapihi pākarukaru	117
› maunga whakahohoro	116
› mūhoretanga whakatumu	119
› paheke	114-115
› pahūtanga taea	115-116
› pakarutanga pūkaha	116
› pakarutanga rama ihuwaka	120
› rere ohotata o te panati	119
› rū whenua	118
› tuinga ihuwaka	120
› waka taupunga	118
tamariki	14, 19, 31, 68, 107, 112, 126, 136, 140, 153, 160-163, 170, 172
tangihanga - rerenga waka	137
tapatoru whakamataara	143
taraka me te pahi	166-167
tarakihana	167
tātua	140-141, 146, 153
tauākītanga hauora	23-24
taumanu waka	147
taumata neneke	176
tautohutanga mō te whakaraihana kaihautū	21-22
tautuku	69-87
tawhiti whaiwhai	55-56, 97, 112

te tikanga 2-hēkena	55, 58, 112, 117, 166
te tikanga 4-hēkena	56, 97, 108
tepenga waipiro, tepenga pūroi	128-130
tere, paetere	122-127
tikanga tautuku	70, 73-76
tikanga whakatemaui	38-39
tiriti ahutahi	52, 91
tiwhikete hauora	24
tiwhikete waka	134, 150
tō i waka kē atu	154-158
tohipa	54, 57-64, 164-169
tohu	28-35
› arawhiti ara-kotahi	87
› autaki	103
› here	29
› kua whakamaua ki te waka	34-35
› mahinga rori	32, 102
› paetere whitiwhiti	127
› pahi kura	126
› pūtahi porotaka	84
› rori matua	67
› tere, paetere	124
› tohu tautuku	29, 70, 71, 74, 87
› tohu whakamataara	31-32
› tukinga waka	126
› tūnga waka	92-94
› tūtei ā-kura	29, 162
› utanga mōrearea	145
› wāhi kura	125
› whakamataaratanga ki te kōpiko	127
› whakamōhio	33
› whakatū	29, 71-72

› whakawhiti ara	103
› whakawhitinga ara tereina	85-86
› whakawhitinga waehīkoi	31
tohu ā-ringa	41-42
tukinga waka	57, 108, 113, 122, 130, 143-145
tukinga waka kawē utanga mōrearea	145
tuku whēkau	24
tūranga waka	88-94
tūranga whaikaha	94
tūtei ā-kura	29, 162
tūtohu	40-44, 77-80, 171

U

utanga	34-35, 148, 154-158
utu whakamahi rori	134, 150

W

waea pūkoro	138-139
waehīkoi	136, 160-163
waka ahuhenua	173
waka ārahi	34, 168
waka nihowhiti aunoa	9, 19, 119
waka hoihoi	136
waka kai tihara - tirohia ko utu kaitāwhai rori	
waka ohotata	43
waka runaruna e whai wīra ana	77, 176
waka whakahara	168
waka whakahara	34-35, 44, 168
waka whakakaurukiruki	136
wīra taupua	138

WH

whaitua huna	45, 68, 70, 108, 166, 168, 222
whaitua matatini	75, 162
whakaaetanga hautū mō tāwāhi	26
whakahoutanga tikanga hautū i te ipurangi	1
whakaita tamariki	140, 153
whakamahinga ara rori	51-54
whakamahinga rama ihuwaka	97-99
whakamana waka	39, 134, 150
whakamātatau hautū waka	12
› raihana here	18
› raihana matua	20
whakaora ohotata	145
whakatumu	56, 97-98, 105, 114, 116, 148
whakaraihana waka	134
whakatangi hāona	136, 137
whakatārewahanga raihana whawhati tata	126, 147
whakatumu pūnaha raka-kore (ABS)	97-98, 114
whakawaitanga kaihautū	139
whakawhitinga atawhai	162, 171
whakawhitinga ara tereina	63, 85-86, 95
whakawhitinga waehīkoi	95, 160-161, 171
whiunga	128-129, 146-147

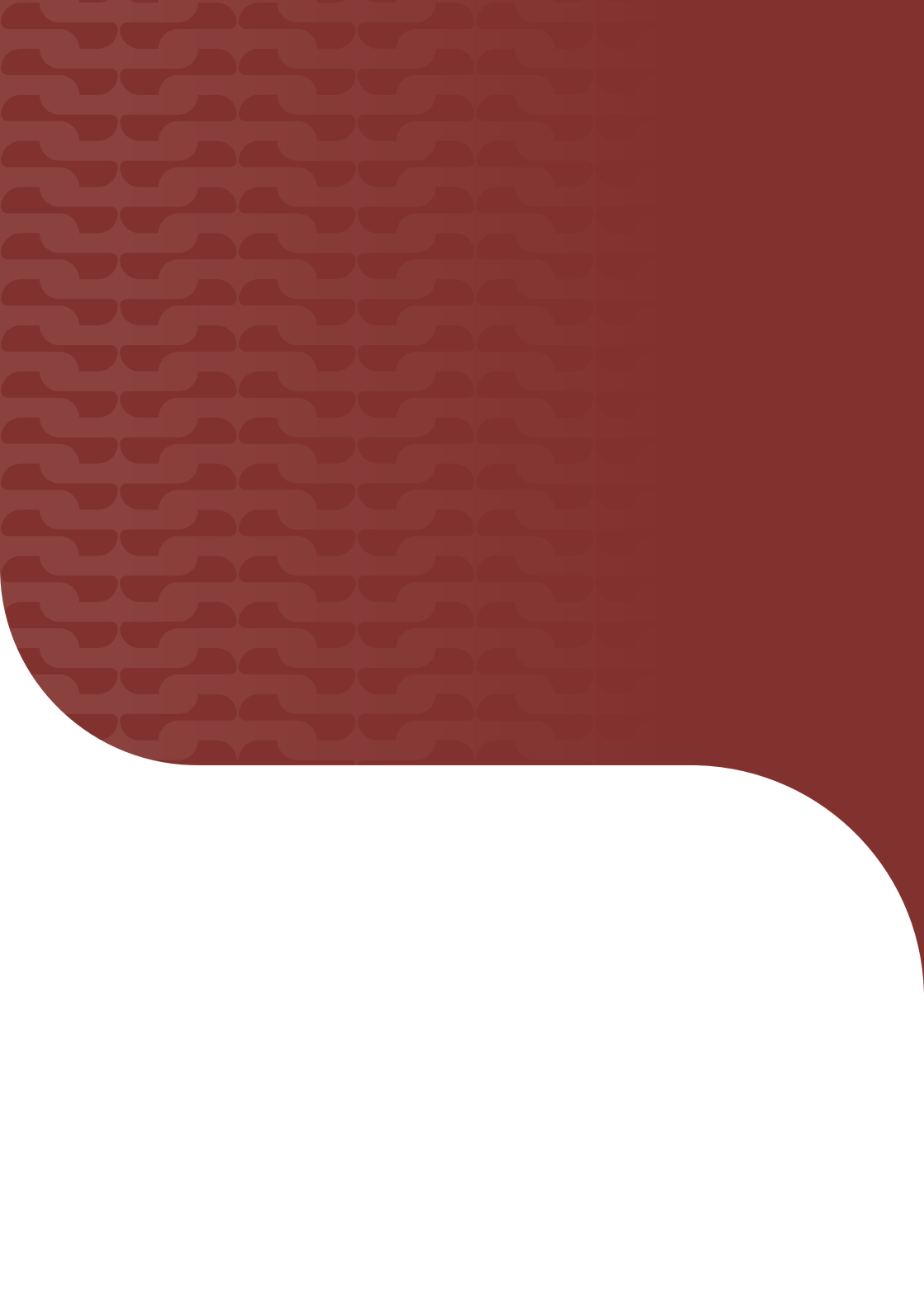

Kei te puka ōkawa o ngā tikanga hautū waka:

- he whakamāramatanga māmā ki ngā ture waka whenua o Aotearoa
- he aratohu mō ngā tūārere katoa e whai ai koe i tō raihana hautū waka
- ngā pātai o ngā whakamātautau ā-tuhi.

Waka Kotahi
Private Bag 6995
Wellington 6141

nzta.govt.nz



Te Kāwanatanga o Aotearoa
New Zealand Government

ISBN: 978-1-99-106883-5



9 781991 068835