

# P43 Specification for Traffic Signals

© Waka Kotahi NZ Transport Agency

Second edition, Amendment 3

Effective from 01 June 2020

ISBN 978-1-98-856116-5



**TABLE OF CONTENTS**

1 General..... 4

1.1 Scope and Foreword ..... 4

1.2 Objectives ..... 4

1.3 Interpretation..... 4

1.4 Outcome of this specification ..... 4

1.5 Review Process..... 4

1.6 Definitions and abbreviations ..... 8

2 Minimum requirements of signal equipment..... 10

2.1 General..... 10

2.2 Signal equipment compliance and approvals ..... 10

2.3 Traffic signal controller ..... 11

2.4 Signal lanterns ..... 14

2.5 Poles (posts) and pole terminal assemblies ..... 14

2.6 Pedestrian and cycle detection..... 17

2.7 Inductive loop detectors (vehicle and cycle) ..... 18

2.8 Uninterruptible Power Supply (UPS) for Traffic Signals ..... 18

2.9 Testing of equipment ..... 20

3 INSTALLATION AND COMMISSIONING OF TRAFFIC SIGNAL EQUIPMENT ..... 21

3.1 General..... 21

3.2 Temporary traffic management ..... 21

3.3 Supply of electric power ..... 21

3.4 Waterproofing ..... 21

3.5 Electrical wiring ..... 21

3.6 Controller cabinet ..... 22

3.7 Controller terminations ..... 22

3.8 External vehicle loop detector units ..... 23

3.9 Pole (post) locations and installation ..... 23

3.10 Signal lanterns ..... 24

3.11 Inductive loops ..... 25

3.12 Pedestrian and cycle push button assembly ..... 27

3.13 Painting and surface coating of equipment ..... 27

3.14 Special tools and keys ..... 28

3.15 Acceptance and testing ..... 28

3.16 As-built documentation to be provided ..... 30

3.17 Procedure for turning off signals..... 30

4 CABLING AND CIVIL WORKS ..... 32

4.1 General..... 32

4.2 Cable diagram..... 32

4.3 Trenching ..... 32

4.4 Cabling, ducting, and signal duct access chambers ..... 32

4.5 Installation of signal poles and mast arm/JUMA/JUSP poles ..... 34

4.6 Controller base ..... 35

4.7 Kerbside junction boxes ..... 35

4.8 Labelling of cables ..... 35

4.9 Cabling documentation ..... 36

5 MAINTENANCE OF NEW WORK DURING DLP ..... 37

5.1 Fault attendance..... 37

5.2 Preventative maintenance during DLP period ..... 37

**Appendices**

Appendix A – Inductive Loop Layout Details ..... 38

Appendix B – 5 Metre Pole Top Assembly..... 40

Appendix C – Signal Pole Details..... 42

Appendix D – Pole Duct Access Details ..... 59

Appendix E – Lantern Shroud Details – Informative ..... 60

Appendix F – Cable Termination Chart Example ..... 61

Appendix G – Site Acceptance Test Chart..... 62

Appendix H – Controller Bench Testing Form ..... 65

Appendix I – Street-light Circuit Example ..... 66

Appendix J – New Intersection Commissioning Form ..... 67  
 Appendix K – RAMM Asset Data Form ..... 69  
 Appendix L – Controller Gland Plate – Informative..... 70  
 Appendix M –Cycle Push Buttons – Informative..... 71  
 Appendix N – Mounting Strap Locking Mechanism ..... 72  
 Appendix O – UPS Prioritisation Chart..... 73  
 Appendix P – UPS LINE–INTERACTIVE TOPOLOGY ..... 74  
 Appendix Q – Minimum UPS Outputs ..... 75

**Tables**

Table 1 – Lantern mounting strap dimensions ..... 24  
 Table 2 – Painting and surface coating of equipment ..... 27  
 Table F01 – Example cable termination chart ..... 61  
 Table G01 – Site acceptance sheet 1 of 3 ..... 62  
 Table G01 – Site acceptance sheet 2 of 3 (continued) ..... 63  
 Table G01 – Site acceptance sheet 3 of 3 (continued) ..... 64  
 Table H01 – Controller bench test form..... 65  
 Table J01 – New installation acceptance (NIA) checklist follows on next page ..... 67  
 Table K01 – Asset information form ..... 69  
 Table O01 – UPS Prioritisation Chart ..... 73

**Figures**

Figure A01 – Vehicle loop details ..... 38  
 Figure A02 – Cycle loop details ..... 39  
 Figure B01 – Pole Top Assembly ..... 40  
 Figure B02 – Pole Top Assembly ..... 41  
 Figure C01 – Type 1 NASSRA Pole Ground Plant ..... 43  
 Figure C02 – Type 1 NASSRA Pole Retention Socket ..... 44  
 Figure C03 – Type 2 Combined CCTV Pole Ground Plant ..... 45  
 Figure C04 – Type 2 Combined CCTV Pole Retention Socket ..... 46  
 Figure C05 – Type 8 Hinged NASSRA Pole Ground Plant ..... 47  
 Figure C06 – Type 8 Hinged NASSRA Pole Retention Socket ..... 48  
 Figure C07 – Type 0 Extension Signals Pole Ground Plant ..... 49  
 Figure C08 – Type 11 Cycle NASSRA Pole with Cycle Hoop - Retention Socket ..... 50  
 Figure C09 – Octagonal JUSP Pole Ground Plant ..... 51  
 Figure C10 – Octagonal JUSP Pole Flange Mount ..... 52  
 Figure C12 –Urban JUSP Retention Socket ..... 53  
 Figure C13 – Type 3s & 5s JUMA - CCTV - Flange Mount ..... 54  
 Figure C14 – Type 3, 5, & 7 JUMA Columns – Street Light Extension - Flange Mount ..... 55  
 Figure C15 – Type 9 Cycle Mastarm Columns - Flange Mount ..... 56  
 Figure C17 – Type 1 NASSRA Pole Cycle Hold Rail Ground Plant ..... 57  
 Figure C18 – Pedestrian Stub Pole Cycle Hold Rail Ground Plant ..... 58  
 Figure D01 – Duct access details ..... 59  
 Figure E01 – Vehicle lantern shroud ..... 60  
 Figure I01 – Typical circuitry for street–lighting powered from a traffic signal controller. .... 66  
 Figure L01 –Bottom of controller with gland plate fitted and access panel fitted ..... 70  
 Figure L02 –Bottom of controller cabinet with gland plate access panel removed ..... 70  
 Figure M01, M02, & M03–Cycle Push Buttons ..... 71  
 Figure N01 –Mounting Strap Locking Mechanism ..... 72  
 Figure P01 – UPS Line–Interactive Topology (as per AS5715:2015 Figure 3.2)..... 74

## P43 SPECIFICATION FOR TRAFFIC SIGNALS

### 1 GENERAL

#### 1.1 Scope and Foreword

##### 1.1.1 *Exclusions*

This document is intended as a technical specification for equipment and best practice during the installation, maintenance and upgrade of traffic signals. Compliance with this specification does not indicate compliance with any other legal or contractual requirements (eg traffic management, health & safety requirements etc).

#### 1.2 Objectives

This specification is intended to encompass best practice for the supply of equipment and its installation at new sites, as well as when undertaking maintenance and upgrade works at traffic signals throughout the country. It is recognised that individual Road Controlling Authorities (RCA) will have their own specific requirements. Therefore, this specification needs to be read in conjunction with the Regional Special Conditions to P43, as produced by the local RCA in which the work is being undertaken.

#### 1.3 Interpretation

For the purposes of this specification, the word 'shall' refers to requirements that are essential for compliance with the specification, while the word 'should' refers to practices that are advised or recommended.

This specification includes a number of appendixes. These appendixes are supplied to allow the provision of greater detail without filling the specification with diagrams.

All appendixes are an integral part of the specification, unless specifically marked as 'Informative'.

RCA's may provide different details than those shown in the appendixes. In that case, it will be noted in the RCA Regional Special Conditions if an appendix is to be considered informative in that region.

#### 1.4 Outcome of this specification

This specification sets out the details for the selection and installation of equipment involved with the installation, maintenance and upgrade of traffic signals and associated systems.

Compliance with this specification will ensure that traffic signal installations will operate reliably, safely and in a consistent manner, regardless of installation location.

#### 1.5 Review Process

This document has been produced by the Signals NZ User Group (SNUG), and continues to be maintained and updated by the SNUG committee.

Any comments and recommendations should be sent to the secretary of the SNUG committee. The SNUG committee will compile comments and recommendations at the annual SNUG meeting for consideration. In the event of a major change the SNUG committee will convene a subgroup to work through and propose changes.

##### 1.5.1 *Interim Update*

To ensure standards are updated and to address industry changes, interim updates will be posted on the SNUG website <http://snug.org.nz/specifications/>

## 1.5.2 Major Updates

### 1.5.2.1 Second Amendment Version 2 – 16 August 2018

Initial issue -----

### 1.5.2.2 Second Amendment Version 3 – 01 June 2020

Maintenance and upgrade added to document scope	Section 1.1, 1.2, 1.4 & 2.1
Update process expanded	Section 1.5.1 & 1.5.2
AS/NZS Standards reviewed and brought up to date	Various sections
UPS information added	Various sections
Glossary added	Section 1.7.3
Provisional approval maintenance obligations amended	Section 2.2.1
Guarantee / Warranty period – clarity around period start	Section 2.2.2
Standby generator connection – new clause added	Section 2.3.2
Street-lighting power connection details expanded, and diagram added	Section 2.3.2, Appendix I
New Controller types - Maintenance Contractor added to (b)	Section 2.3.5
Extended range signals use as directed by RCA	Section 2.4.2
Fall restraint mountain made mandatory on new poles	Section 2.5.1
Pole retention socket added as a mounting option	Section 2.5.1.3
Pole electrical warning label requirement added	Section 2.5.1.3
Cycle loop layout change & external DET requirements amended	Section 2.7.1, 3.11.4, Appendix A
Labelling requirements around termination of multiple cables clarified	Section 3.5.1
External detector power supply clarified	Section 3.8
Pole location prior to installation requirements	Section 3.9 & 4.5
SCATS loop futureproofing requirements included	Section 3.11
Pedestrian and cycle push button assembly arrow orientation	Section 3.12
Software (personality) Testing requirements added	Section 3.15.3
Signal duct access chambers location and cover clarification	Section 4.4.2
Fault attendance error rectified (able amended to unable)	Section 5.1
Traffic signal poles figure C11, C16 deleted and C12 renamed	Appendix C
Software Check sheet, minor wording amendments	Appendix H
Cycle push button unit – additional picture (M03) added	Appendix M

## 1.6 REFERENCED DOCUMENTS

The users of this specification should ensure that their copies of the following documents are the latest revisions. Note that standards are frequently updated, and references contained within this standard may not keep pace with such changes. The reader is to satisfy themselves that the essence of this standard is being adhered to,

Reference is made in this document to the following:

### NEW ZEALAND STANDARDS

NZS 3109	Concrete construction
NZS 3114	Specification for concrete surface finishes
NZS 3404	Steel structures standard (Parts 1 & 2)
NZS 3910	Conditions of contract for building and civil engineering construction

### JOINT AUSTRALIAN/NEW ZEALAND STANDARDS

AS/NZS 1163	Cold-formed structural steel hollow sections
AS/NZS 1170	Structural design actions

	Part 0:2002	General principles
	Part 1:2002	Permanent, imposed and other actions
AS/NZS 1554		Structural steel welding
	Part 1:2014	Welding of steel structures
AS/NZS 2276		Cables for traffic signal installations
	Part.1	Multicore power cables
	Part 2	Feeder cables for vehicle detectors
	Part 3	Loop cable for vehicle detectors
AS/NZS 2312	Part.1	Guide to the protection of structural steel against atmospheric corrosion by the use of protective coatings
AS/NZS 2980		Qualification of welders for fusion welding of steels
AS/NZS 3000		Electrical wiring regulations
AS/NZS 4058		Precast concrete pipes
AS/NZS 4676		Structural design requirements for utility services poles
AS/NZS 4677		Steel utility services poles
AS/NZS 4680		Hot-dip galvanized (zinc) coatings on fabricated ferrous articles
AS/NZS 5131		Structural steelwork – Fabrication and erection

### INTERNATIONAL STANDARDS

IEC 60947		Low-voltage switchgear and control gear
	Part 7-1	Ancillary equipment – Terminal blocks for copper conductors
IEC 60998		Connecting devices for low-voltage circuits for household and similar purposes
	Part 1	General requirements
	Part 2-1	Particular requirements for connecting devices as separate entities with screw-type clamping units

### AUSTRALIAN STANDARDS

AS 2144		Traffic signal lanterns
AS 2339		Traffic signal posts and attachments
AS 2353		Pedestrian push button assemblies
AS 2578		Traffic signal controllers
AS2700		Colour Standards for General Purposes
AS 2703		Vehicle loop detector sensors
AS 3996		Access covers and grates
AS5715		Uninterruptible power systems (UPS) for roadside devices

### WITHDRAWN STANDARDS

The following standards have been withdrawn but not yet replaced, as such they are still being referenced within this standard. Where new and old standard conflict refer to the interim update or :

AS 2578		Traffic signal controllers (withdrawn 2019)
NZS 5431		Specification for traffic signals
AS/NZS 4676		Structural design requirements for utility services poles (withdrawn 2017)

### OTHER PUBLICATIONS

NZCEP 34		New Zealand code of practice for electrical safe distances
RTS14		Guidelines for facilities for blind and visually impaired pedestrians, third edition – May 2015, Roads and Traffic Series
CoPTTM		Code of practice for temporary traffic management (NZTA Publication)
Austrroads		Guide to traffic management, Part 10, Traffic Control and communication devices
RMS TSC/4		Compliant controller specification
NZTA		Pedestrian planning and design guide
MRTS252		Next Generation Traffic Signal Controllers – Transport and Main Roads – Queensland
TCS 016		The Supply and Installation of Traffic Signal Controllers – Vic roads



## NZTA P43 – SPECIFICATION FOR TRAFFIC SIGNALS

---

### 1.7 Definitions and abbreviations

#### 1.7.1 *Definitions*

For the purpose of this specification this specification, unless inconsistent with the context, the following definitions apply.

<b>Engineer</b>	As Per NZS 3910 “Conditions of contract for building and civil engineering construction”
<b>Client</b>	As Per NZS 3910 “Conditions of contract for building and civil engineering construction”
<b>Contractor</b>	As Per NZS 3910 “Conditions of contract for building and civil engineering construction”
<b>RCA Traffic Signal Engineer, Also referred to as Signal Engineer</b>	The RCA Traffic Signal Engineer is ultimately responsible for traffic signals for the RCA. This person is a technical person and is not generally associated with the contract. They are the Traffic Signal Engineer who will be operating the installation once it is completed. Larger RCA’s have delegated this responsibility to Transport Operations Centres (TOC’s). It is the traffic signal contractor’s responsibility to verify who the RCA Traffic Signal Engineer is before any work commences.



### 1.7.2 *Abbreviations*

Abbreviations used in this specification have the following meaning. The singular includes the plural and the plural includes the singular.

<b>AS</b>	Australian Standard
<b>CIS</b>	Controller Information Sheet
<b>DLP</b>	Defects Liability Period
<b>ELV</b>	Extra Low Voltage
<b>HHT</b>	Hand Held Terminal
<b>JUMA</b>	Joint Use signal Mast Arm and streetlight pole
<b>JUSP</b>	Joint Use signal and Streetlight Pole
<b>KJB</b>	Kerbside junction box
<b>LED</b>	Light Emitting Diode
<b>MCB</b>	Miniature Circuit Breaker
<b>MPa</b>	Megapascals
<b>NATA</b>	National Association of Testing Authorities (Australia)
<b>NZS</b>	New Zealand Standard
<b>NZTA</b>	New Zealand Transport Agency
<b>PROM</b>	Programmable Read-Only Memory (controller configuration)
<b>PVC</b>	Polyvinylchloride
<b>RAMM</b>	Road Assessment and Maintenance Management
<b>RCA</b>	Road Controlling Authority
<b>RCD</b>	Residual Current Device
<b>RMS</b>	Roads & Maritime Services (the developers of SCATS)
<b>SCATS</b>	Sydney Co-ordinated Adaptive Traffic System
<b>SPT</b>	Special Phase Time
<b>TMP</b>	Traffic Management Plan
<b>TRAFF</b>	Internal Operating System for Traffic Signal Controller
<b>UMB</b>	Upper Mounting Bracket
<b>UPS</b>	Uninterruptible Power Supply
<b>V</b>	Volts

### 1.7.3 *Glossary*

Terms used in this specification.

<b>Brownout</b>	Where the voltage drops to below the minimum allowable supply threshold.
-----------------	--

## 2 MINIMUM REQUIREMENTS OF SIGNAL EQUIPMENT

### 2.1 General

Section 2 sets out the requirements of all signal equipment offered for supply and installation, whether for new sites, upgrades or through maintenance, including, the local signal controller, controller cabinet, uninterruptible power supply, detectors, lanterns, target boards, visors, poles and pole top assemblies, and push button assemblies.

#### 2.1.1 *Uninterruptible Power Supply (UPS) for Traffic Signals*

##### 2.1.1.1 *Purpose*

An Uninterruptible Power Supply (UPS) system for traffic signals provides emergency auxiliary power to traffic signals during a power outage, providing both a safe and efficient journey for road users in these events. In addition, UPS systems have also proved to extend the life of the traffic controller by reducing the adverse effects of brownouts and maintaining a consistent flow of current to the traffic controller.

##### 2.1.1.2 *Factors for UPS Prioritisation*

Appendix F serves as a guideline when prioritising the installation of UPS systems at signalized intersections. The factors and weightings included in the appendix are by no means definitive, but rather to be used as a reference to assist individual Road Controlling Authorities (RCA) in making an assessment when prioritising the installation of UPS systems at signalised intersections.

### 2.2 Signal equipment compliance and approvals

All traffic signal components shall comply with this specification and shall either:

- (b) Have been previously supplied to the road controlling authority (RCA) or client, and found satisfactory in operation, or
- (c) Be demonstrated in a working condition and given approval by the RCA Traffic Signal Engineer before the closing date for tenders. The Engineer may give provisional approval if, in the RCA Traffic Signal Engineer's opinion, the equipment is fit for purpose and is able to be connected to the Sydney co-ordinated adaptive traffic system (SCATS) traffic management system (if required to be connected to SCATS). See Section 2.2.1.

The equipment shall also comply with all relevant electrical regulations and local power supply authority's requirements.

#### 2.2.1 *Provisional approval*

Provisional approval for non-complying equipment may be given by the RCA Traffic Signal Engineer for Regional Approval providing it can be shown that the proposed equipment meets all specified requirements, including safety and other regulatory requirements, and provides the same desired outcome.

Equipment with provisional approval is required to operate in accordance with this specification, and the associated regions special conditions. This will not remove the contractor's maintenance obligations detailed within this specification or as amended by a specific clause in the associated RCA's Regional Special Conditions to P43. In many cases, equipment with provisional approval may require maintaining for a longer period than 1 year. The contractor will be notified of this period when granted provisional approval. Maintenance, at no cost to the RCA or client, will be required until full approval for the equipment is given.

In general, equipment will be required to operate under normal working conditions without failure for a period of 12 months. This may apply to one-off, or a multiple number, of units.

## **2.2.2** *Guarantee / Warranty period*

Unless specified elsewhere in this specification, all equipment and hardware supplied or installed shall be guaranteed by the manufacturer against faulty materials and workmanship for a minimum period of [1] year from the date of commissioning.

The guarantee period commences from the date of commissioning and not the date of manufacture or installation.

Where there is a difference between the main contract's defects and liability requirements and this specification, the longer time period shall apply.

Exceptions to the above include: traffic signal controller components (as per manufacturer), UPS controller (as per manufacturer), UPS Batteries (5 years), poles, and painting (10 years).

LED (lamp) modules shall have a 5-year guarantee period. For new installations, the guarantee period shall commence from the date of commissioning. For replacement modules, the guarantee period shall commence from the date of installation of the LED (lamp) module.

For new installations and substantial refurbishments, commissioning of the signals shall be deemed to have occurred on the date when the installation has passed all of the pre-commissioning tests and the RCA Traffic Signal Engineer has signed the site acceptance (or similar) form and when all defects, (minor or other), have been addressed.

All guarantee and warranty work must be done at no cost to the asset owner, or their representative.

See Section 5 for cost liabilities for any failure or fault during the contract maintenance or defects liability period.

## **2.3** **Traffic signal controller**

### **2.3.1** *AS 2578:2009 – Traffic signal controller*

Note: AS 2578:2009 has been withdrawn with no replacement. As such the latest version is still being referenced for the time being.

Subject to the following special conditions, the traffic signals controller shall comply with AS 2578. This includes all aspects of the controller, cabling, mounting, cabinet, and logic rack as detailed in AS 2578, including the provision of options as detailed in Appendix A of AS 2578.

### **2.3.2** *New Zealand special conditions to AS 2578:2009*

The following amendments shall be made to AS 2578 for supply and installation in New Zealand under P43. The numbers referred to are the clause numbers in AS 2578.

#### *1.4.10 – Additional requirement for New Zealand*

In accordance with AS/NZS 3000, the RCD supplied shall meet the conditions of 2.6.2.2 of AS/NZS 3000 for New Zealand installations.

#### *2.3.3 – Additional requirement for New Zealand*

The controller should have ventilation grilles in the base, above the finished ground level, and below the gland plate as detailed in 2.3.4. A recommended option is to fit a 'pedestal' between the base and the controller cabinet. This pedestal shall be at least 100 mm tall, and the same width and depth as the controller cabinet and base.

#### *2.3.4 – Additional requirement for New Zealand*

A gland plate and removable access panel shall be fitted at the bottom of the controller cabinet. A suitable example is shown in this specification Appendix L. Any unused cable entries shall be 'plugged' with plugs that can be easily removed. The glands, gland plate, and access panel shall prevent entry of vermin and so on into the bottom of the controller cabinet with all gaps to be sealed with RTV silicon to stop insects entering the cabinet.

The access panel shall be installed to allow easy removal for maintenance tasks in the bottom of the cabinet.

*2.3.7 – For New Zealand delete Figure 2.5.*

*2.3.7 – Additional requirement for New Zealand as per NOTE.*

The purchaser requirement for New Zealand cabinet locking is as follows:

- (a) Recessed handle(s);
- (b) Three-point locking at top, bottom, and side;
- (c) A single-key mechanism; with the lock keyed for FS880, unless specified by the local RCA's regional amendments to P43.

*2.3.12 – Change requirement for New Zealand*

*Replace second paragraph with –*

The equipment shelf shall be mounted not less than 390 mm below the top of the door opening, and this shelf shall be the width of the controller cabinet.

*Clause 2.3.12 – Additional requirement for New Zealand*

The equipment shelf shall be sufficiently deep enough to hold the logic module but shall have at least 50 mm clearance from the front face to the inside of the door.

*New clause for New Zealand*

**Communications socket outlet and MCB**

A circuit breaker shall be installed in the 'spare position' defined in AS2578:2009, Section 2.5.11(f). This circuit breaker shall be rated at 16 A, Type C, with a fault-make load-break fault current rating not less than 8 kA and shall control a new double-socket outlet specifically for communications and camera equipment, where the 230 V power for such equipment is supplied by 3-pin plug. The communications equipment socket outlet shall be clearly labelled 'Communications equipment only – NOT RCD PROTECTED'. RCD protection shall not be provided for this socket.

*New clause for New Zealand*

**Stand-by generator connection**

*The controller housing shall be fitted with all of the facilities required for the connection of an external generator as specified in AS 2578. The controller housing connector for the external generator shall be a male three-pin (flat) 15A connector complying with AS 3112.*

*It is desirable that the 'presence of power' indicator lights specified in AS 2578 are green to indicate mains supply and yellow to indicate generator supply. The indicator lights should have a design life of at least 15 years.*

*New clause for New Zealand*

**Street lighting power**

Where there is a power supply to street-lighting mounted on a shared traffic signal pole. It may be fed through the traffic signals control cabinet.

The street-light power circuit shall be supplied through the traffic signal controller mains power isolation switch.

A dedicated MCB shall be provided and shall be installed in the 'spare position' defined in AS2578:2009, Section 2.5.11(f). Where the detector' MCB detailed in AS2578:2009 Section 2.5.11 (d), is not being utilised and if suitably rated, it may be reassigned as the street-lighting circuit protection, in which case it shall be clearly relabelled

Appendix I, Figure R01 shows an example of street-lighting fed through the traffic signal controller.

*New clause for New Zealand*

**Electricity revenue meter**

Each electricity retailer and each electricity lines company have slight variations with their electricity revenue meter requirements. For regional specifics, consult the local RCA's regional amendments to P43.

*2.13.1 – Change requirement for New Zealand*

*Replace the entire paragraph with –*

**Conformance with New Zealand communication requirements**

Any device designed or intended for connection to a telecommunications network shall comply with the applicable requirement:

- (a) Telepermit requirements – Any device to be directly connected to the Chorus network shall display the New Zealand Telepermit label. For more information visit <http://www.telepermit.co.nz>.
- (b) Radio requirements – Any wireless device shall comply with the (New Zealand) Radiocommunications Act. For more information visit <http://www.rsm.govt.nz>.

*2.18 – NOTE*

The service light is a standard requirement for all New Zealand controllers.

*2.22.5 (b) – change requirement for New Zealand*

Replace entire requirement with 'Telepermit label and PTC number'.

**2.3.3 Controller firmware**

Prior to testing and installation, the following requirements shall be met:

- (a) The controller shall be designed in accordance with the Roads and Maritime Services (RMS) TSC4 specification;
- (b) The controller (including logic rack and all other modules) shall have the current manufacturer software, firmware, and hardware updates applied at the time of installation.

**2.3.4 SCATS compliance and TRAFF version**

Where the controller is to be connected to SCATS, the following conditions apply:

- (a) The controller shall be running the latest version of TRAFF software, as notified by RMS;
- (b) A copy of the RMS SCATS compatibility certificate for that model of controller shall be supplied to the RCA Traffic Signal Engineer, if requested or not previously supplied.

**2.3.5 New controller types**

Where a contractor proposes to install a new controller type not previously installed in the area of the RCA, the following conditions shall be met:

- (a) Written approval shall be obtained from the RCA Traffic Signal Engineer;
- (b) The supplier (or their agent) shall offer to make a presentation on the controller to the RCA Traffic Signal Engineer and provide a loan logic rack at no charge to allow the RCA Traffic Signal Engineer and maintenance contractor, to test the controller and become familiar with it;
- (c) The supplier (or their agent) shall provide a training course to the RCA's existing maintenance contractor, at no charge to the engineer or the maintenance contractor;
- (d) If the new controller requires special configuration tools, or will not work with the RCA's maintenance contractor's HHT, the supplier (or their agent) shall provide all equipment required to allow full HHT operation with the controller. This may include computer hardware & software, or a new HHT, as required by the RCA Traffic Signals Engineer to integrate with the operations of the current maintenance contractor;
- (e) The RCA Traffic Signal Engineer has the final right to deny installation of any controller type in their area.

## 2.4 Signal lanterns

### 2.4.1 *General*

The technical requirements for traffic signal lanterns including cowls, visors, and louvres shall be as stipulated in AS 2144, including amendments as issued from time to time, with the exception that all new traffic signal lanterns shall be supplied with LED lamps.

### 2.4.2 *Signal sizes*

The nominal size of pedestrian and general-purpose signals, as referred to in AS 2144, shall be 200 mm.

The nominal size of extended range signals, as referred to in AS 2144, shall be 300 mm.

Extended range signals shall be used on all overhead mast arm displays and on high speed approaches or as directed by the RCA Engineer.

### 2.4.3 *LED lanterns*

All LED lanterns, visors, louvres and target boards shall comply with this specification. In addition LED lanterns shall have an independent NATA certified laboratory report confirming compliance with AS 2144. This must be supplied to the RCA Traffic Signal Engineer on request.

### 2.4.4 *Lantern body construction*

Lantern bodies shall be constructed from aluminium and be installed to the manufacturers' installation instructions.

The lantern doors shall be capable of being hinged on both the left and right without the need for tools. Lantern doors shall be able to be replaced without the need to disturb the lantern mountings.

### 2.4.5 *Visors (cowls)*

Each visor shall fit tightly against the door and shall not permit any perceptible filtration of light between the door and the visor.

All visors shall be made from plastic.

Unless specified elsewhere, all visors shall be one of the following:

- (a) Open type visor – For use on primary lanterns;
- (b) Closed type visor – For use on secondary or tertiary lanterns;
- (c) Pedestrian visor – Each standard 200 mm diameter pedestrian lantern shall be fitted with an approved rectangular visor.

### 2.4.6 *Target boards (backing boards)*

Target boards shall be fitted to each vehicle lantern supplied. The target boards shall be as specified in AS 2144, and shall be constructed using type 5005 aluminium alloy with a minimum thickness of 1.6 mm. Each target board shall be fully interchangeable in accordance with the criteria recommended in Appendix F of AS2144. The surface treatment shall be baked enamel (black).

All target boards shall incorporate a white border as detailed in AS2144.

## 2.5 Poles (posts) and pole terminal assemblies

### 2.5.1 *Traffic poles*

The design requirements for all traffic poles shall be in accordance with AS/NZS 4676 and AS/NZS 4677.

Design of the components for strength will be in accordance with the parameters set out in (a) to (g) below.

Only poles and arms in accordance with the drawings in Appendix C are to be installed. Variations from these standards will require written approval from the RCA's Traffic Signals Engineer.

All traffic poles, including mast arm poles, standard traffic signal and hinged traffic signal poles, JUMA, JUSP, ground planted, flange based, or flange based stub shall be designed in accordance with AS/NZS 1170.0 and AS/NZS 1170.1, and include a 10-year structural guarantee.

Additionally, the following specific design parameters are to be included:

- (a) Design working life – 50 years;
- (b) Importance level – 2;
- (c) Wind region – Use code for region where traffic signals are to be installed;
- (d) Terrain/height multiplier – 2;
- (e) Shielding multiplier – 1;
- (f) Hill shape multiplier – 1;
- (g) Lee zone multiplier – 1 (to a maximum of 1.35).

All JUSP, JUMA, and mast arm poles with curved outreach arms shall have a 10-degree tilt. In addition, poles and arms shall comply with all dimensions shown in Appendix C. The minimum spigot diameter on JUSP and JUMA poles shall be 42 mm outside diameter (OD). In the case of the JUMA and JUSP poles, the street lighting luminaire fitted to the outreach arm shall not exceed 0.15 m<sup>2</sup> in sail area and have a mass of no more than 15.0 kg. The tilt angle shall be detailed on the drawings.

All fixtures and fittings are detailed (traffic signals, pedestrian signals, street lights, signage, and any other fittings or fixtures required for the specific installation) along with the height at which their weight and windage is to be calculated as a minimum. Drag coefficients are to be in accordance with Table E4 of AS/NZS 4676.

The JUSP pole door cavity/fuse opening shall be of a suitable weatherproof design and shall be positioned to permit safe access for maintenance (not facing the street/traffic lane). The ideal position would be to allow the technician to view oncoming traffic. The cover plate shall be secured by a minimum of two child and vandal resistant 304 grade stainless steel fasteners and will require a specialised tool to remove the fasteners for maintenance.

In the case of octagonal JUSP poles, the door cavity/fuse opening shall be a standard size of 300 mm x 140 mm and be positioned 600 mm (to the base of the opening) above the finished ground level. In the case of the JUMA pole, the door cavity/fuse opening for the street light isolation shall be a standard size of 180 mm x 80 mm and be positioned just below the mounting flange for the street light outreach arm.

All steel tube used for manufacture of the 5.1 m traffic light poles shall be a minimum of 100 nb (nominal bore) CHS (Circular Hollow Section) to C250LO in accordance with AS/NZS 1163.

Pole strengths are based on NZS 3404. Steel section strength requirements apply to the base of the pole at the top of the concrete footing.

All welding shall be carried out in accordance with AS/NZS 1554.1, with welders qualified to AS/NZS 2980. Inspection certificates by a duly qualified independent inspection company are to be supplied for each batch manufactured.

Suitable mounting points for a fall restraint system shall be provided for all new poles.

#### **2.5.1.1** Pole identification

Poles shall be permanently marked (prior to painting) by way of indentation stamp to indicate date of manufacture (dd/mm/yyyy) and the name of the manufacturer. This

indentation stamp shall be located immediately under the lower pedestrian mounting lug. Arms are to be identified in the same manner with the location being on the outer surface, immediately above where the arm connects to the pole. The indentation stamp letter and number size is to be of a size suitable to be easily identified. Lettering shall have a minimum height of 7 mm and a maximum height of 14 mm. All marking is to be applied prior to painting.

#### **2.5.1.2** *Pole Finish*

All JUMA, JUSP, and mast arm poles and arms shall be finished, both internally and externally, in accordance with AS/NZS 4680. Ready galvanised steel, spray on galvanising or thermal zinc will not be accepted. In addition, pole coatings shall be in accordance with AS/NZS 2312.1 with certification to Category C4 for a 10-year warranty to first maintenance.

#### **2.5.1.3** *Pole Installation*

Each pole type will require a PS1 certificate to be issued by a suitably qualified Chartered Professional Engineer. This certificate shall include the specific design details for both the pole and, when requested, the foundation details, and will be supplied at time of tender.

Mounting of the poles are of three possible types – ground planted, concrete pad or retention socket.

Ground planted poles are an extension of the pole below the finished ground surface. The length below ground will vary depending on the model of pole being installed and ground conditions in the location. The minimum soil bearing capacity should be 100 kPa. A site-specific foundation design will be required for any capacity less than 100 kPa.

Concrete pad mounted poles will typically be of a flange based type. These poles will require a concrete pad or pile to be constructed that will include during pouring the use of a suitable holding down bolt cage. Pads and piles are typically used in locations where the ground conditions are not stable enough to maintain overturning resistance.

Retention sockets are installed in the ground utilising various foundation designs to suit the available depth and ground conditions. The pole can be cabled at ground level and is then slotted into the ground socket reducing the H&S risk of working at height. In the event of a knockdown the pole can be replaced. Typical foundation details can be sourced from the suppliers, however each design should be checked for suitability depending on ground conditions.

### **2.5.2** *Pole terminal assemblies*

#### **2.5.2.1** *Switch terminations (terminal assemblies)*

The terminal assembly shall consist of sufficient 2.5 mm 2-in-2-out knife edge disconnect terminals for the number of cores to be terminated. The terminals shall be spring loaded screw locked incorporating a screw and spring-tensioned system or have a minimum of one screw per cable core. The neutral and earth terminals shall be double through terminals to facilitate a greater number of terminations. The terminals shall be mounted on aluminium rails and end clamps shall be provided at each end of the rail. Each terminal shall be clearly labelled.

#### **2.5.2.2** *Neutral terminations*

The terminals shall meet the requirements of 2.5.2.1, except that they shall not use switch terminations.



### 2.5.2.3 *Earth terminations*

The earth bus bar shall provide ten outputs with connectable cross-sections measuring 10 mm<sup>2</sup> and 16 mm<sup>2</sup> configured alternately. The bar shall be rail mounted and have a rated voltage of 450 V and be rated IP20. The insulating material shall meet IEC 60998 Part 1 and Part 2-1.

### 2.5.2.4 *Five metre pole termination (terminal assembly unit)*

The top of each standard 5 m pole shall be fitted with a terminal assembly unit and cover meeting the requirements as shown in Appendix B.

The pole top and full Upper Mounting Bracket (UMB) shall be a combined unit, complete with cable terminal and lantern lead supports, and a finial cap capable of being fastened into position so that it cannot be removed if the securing bolts are loose.

The finial cap shall be made of plastic and constructed to fit snugly over the pole top to minimise the ingress of dirt and grime. The finial cap shall be secured to the UMB by a wire lanyard to prevent it from blowing away if not fastened correctly. Do not use metal finial caps.

All nuts, washers, bolts, and fasteners shall be galvanised, and the pole top/mounting bracket shall be constructed in a non-corrosive material.

### 2.5.2.5 *Mast arm pole termination*

All mast arm poles shall have a terminal assembly box (montrose box) mounted no lower than 3.5 m from the adjacent ground level.

The box shall be constructed from aluminium, stainless steel or polycarbonate with minimum dimensions of 400 mm x 350 mm x 120 mm rated to IP65. The box must be suitable for its location and have a design life of a minimum of 10 years. It shall be bolted to the pole and shall include a rubber seal or gland between the box and the pole metalwork to create a waterproof seal. The lantern leads shall enter through the underside of the box. Any cables entering through the back of the box shall be held by a compression gland. No holes will be permitted in the box that will allow condensation or moisture to enter.

All cables shall be terminated in accordance with the details shown on the cable termination chart (see Appendix F for example).

### 2.5.2.6 *Pole Warning Label*

All new traffic signal poles shall be fitted with a permanent warning label "Danger Live Wires". The label is to be fitted at the base of each new pole following installation. For existing poles, a suitably worded label is to be attached following any work being undertaken on the pole or mounted equipment.

## 2.6 Pedestrian and cycle detection

### 2.6.1 *Pedestrian push button assemblies*

Pedestrian push-button assemblies shall contain audio and tactile facilities and shall comply with AS 2353.

In addition, the following requirements shall be met:

- (a) The call box shall provide an audible locating and 'WALK' signal;
- (b) The audible locator shall incorporate ambient noise control;
- (c) The tactile function shall be continually operational; however, the audio signal should be able to be muted.

### 2.6.2 *In ground or above ground pedestrian detection*

All in ground (IGD), above ground (AGD), and related equipment shall be approved by the RCA Traffic Signal Engineer before installation.

### 2.6.2.1 *In ground pedestrian detection*

In-ground pedestrian detection systems are currently not accepted as the means for pedestrian detection at new installations.

### 2.6.2.2 *Above ground pedestrian detection*

All AGD units shall be located such that they are able to cover the required area of detection and shall be compatible with the traffic signal controller detection and operation.

### 2.6.3 *Cycle push-button assemblies*

Cycle push-button assemblies shall be the same as the pedestrian push-button assemblies except that:

- (a) They shall be coloured blue;
- (b) The audio and tactile facilities are not required;
- (c) The embossed arrow disc shall be replaced with either a red lens similar to a vehicle signal lens, and embossed with the cycle symbol or a similar cycle indication disc;
- (d) They shall incorporate a visual call accept signal.

Examples of cycle push-buttons can be found in Appendix M.

## 2.7 **Inductive loop detectors (vehicle and cycle)**

Inductive loop detectors may be either preformed or saw cut on site.

Where preformed loops are to be installed they shall have site specific approval of the RCA Traffic Signal Engineer. Each preformed loop shall be constructed to meet the dimensions and lane offsets as in the diagram in Appendix A.

Where non-inductive detection technology is to be used (such as camera technology) it shall have site-specific approval of the RCA Traffic Signal Engineer.

### 2.7.1 *Cycle Detection*

#### 2.7.1.1 *Induction loops*

The current compliant controller hardware is not designed to detect with accuracy cycles. The modern materials of today's bicycles do not create a sufficient inductance change in the loop flux to change the loops oscillating frequency.

At critical sites above ground detection has been shown to be more effective.

#### 2.7.1.2 *External cycle detection*

The best option today as for critical cycle detection is to install an external device dedicated and configured to detect just bicycles, and the input signal configured into the personality software and presented to the controller as an EXTERNAL INPUT. There are various such devices and the contractor should work with the RCA Traffic Signal Engineer in selecting the most suitable device for the location

## 2.8 **Uninterruptible Power Supply (UPS) for Traffic Signals**

### 2.8.1 *General*

The manufacture, supply and installation of Uninterruptible Power Supply (UPS) systems for Traffic Signals shall conform to AS 5715:2015, unless otherwise stated in Clause 2.8.2.

Where a contractor proposes to install a new UPS type not previously installed in the area of the RCA the Contractor is to seek approval from the RCA Traffic Signals Engineer and follow the approval procedure below:

- a) Written approval shall be obtained from the RCA Traffic Signal Engineer;
- b) The supplier (or their agent) shall offer to make a presentation on the equipment to the RCA Traffic Signal Engineer,

- c) The supplier (or their agent) shall provide a training course to the RCA's existing maintenance contractor, at no charge to the engineer or the maintenance contractor;
- d) If the new equipment requires special configuration tools, the supplier (or their agent) shall provide all equipment required to allow full operation. This may include computer hardware & software, as required by the RCA Traffic Signals Engineer to integrate with the operations of the current maintenance contractor;
- e) The RCA Traffic Signal Engineer has the final right to deny installation of any equipment type in their area.

### 2.8.2 *New Zealand Specific Requirements to AS 5715:2015 Appendix D*

The following are specific requirements of the UPS system, and are as listed in AS5715:2015 Appendix D. Each requirement is to be as specified here or where relevant specified by the RCA Traffic Signals Engineer.

In general, the UPS system:

**UPS topology** – shall utilise a line-interactive topology (see Appendix P)

**Load capacity** – as specified by the RCA Traffic Signals Engineer

**Load support time** – should have a minimum load support time of 5 hours

**The rating of the plug for the generator connection, as either 10 A or 15 A** – the fuse shall be specified by the RCA Traffic Signals Engineer

**Battery type** – shall be proposed by the contractor and require approval by the RCA Traffic Signals Engineer

**Battery shelving option** – shall be subject to approval by the RCA Traffic Signals Engineer

**Housing material** – shall comply with the housing requirements for traffic signal controllers detailed in this specification

**Housing colour** – shall comply with the housing requirements for traffic signal controllers detailed in this specification

**Dimensions for non-standard housing** – shall comply with the housing requirements for traffic signal controllers detailed in this specification

**Type of door lock required for UPS housing** – shall comply with the lock requirements for traffic signal controllers detailed in this specification

### 2.8.3 *Additional Clauses to AS 5715:2015 for New Zealand*

#### 2.8.3.1 *Suitability of UPS systems with non-LED traffic signal lanterns*

UPS Systems are only intended for use with LED traffic signal lanterns due to the low energy consumption of LEDs. Other forms of traffic signals are not considered compatible for UPS systems without upgrading to LEDs prior to the installation of a UPS system.

#### 2.8.3.2 *Suitability of UPS systems with auxiliary equipment*

Where additional auxiliary equipment such as CCTV, comms routers or signs are to be connected to the UPS it is necessary to ensure that the UPS can manage the additional loads necessary.

#### 2.8.3.3 *UPS Software requirements*

The UPS system shall be connected to the traffic signals controller, with the UPS software allowing the RCA Traffic Signals Engineer to use SCATS (Sydney Co-ordinated Adaptive Traffic System) flags to indicate different UPS states. The UPS software shall include direct remote monitoring, such that the TOC and RCA shall be able to remotely log into the UPS device for fault checking and monitoring via means determined by the RCA engineer. The minimum required outputs are listed in Appendix Q, which is an extract from AS 5715:2015 Cl4.6.

#### **2.8.3.4** *Relocation of the Generator Connection*

The UPS system shall comply with AS 5715:2015 Cl5.3.16 Stand-by generator connection. Where a UPS system is installed, the traffic signals controller generator connection is to be modified, such that the portable power generation is to be connected to the UPS controller rather than the traffic signal controller.

#### **2.8.3.5** *Cabinet*

All components of the UPS system shall be fully contained in a single UPS system cabinet. All components of the UPS cabinet (e.g. doors, hinges, locks etc.) shall comply with relevant New Zealand standards and clauses in this specification for traffic signal controller cabinets.

Where a UPS system is to be installed at a new signalised intersection, all components may be contained in the Signal Controller cabinet, subject to the approval of the RCA Traffic Signal Engineer.

#### **2.8.3.6** *Electrical Components*

All electrical components including cabling equipment of the UPS system shall comply with relevant New Zealand standards and clauses in this specification.

#### **2.8.3.7** *Additional Signage Requirements*

Additional signage and warning signs are to be placed in the traffic signals controller cabinet, the UPS system cabinet, and the mains power line. These signs shall alert all personnel that during maintenance, power from the UPS system may still be live, even though power from the mains has been turned off.

#### **2.8.3.8** *Testing, Commissioning and Maintenance*

The UPS system shall comply with Clause 2.9 and relevant Subclauses of 3.15 of this specification with respect to testing, commissioning and acceptance of the UPS system.

As a minimum, an annual test shall be undertaken to ascertain the condition of the batteries, to check that the stored energy is within the anticipated energy range to operate the intersection for the desirable minimum duration as defined by the RCA Traffic Signals Engineer in section 2.8.2.

## **2.9 Testing of equipment**

All signal equipment supplied or installed, including the signal controller, UPS, load switching equipment, cable terminals, plugs, and so on, is to be fully tested under simulated working conditions before being installed on site.

For acceptance and testing during installation, see Section 3.15.

## 3 INSTALLATION AND COMMISSIONING OF TRAFFIC SIGNAL EQUIPMENT

### 3.1 General

Section 3 sets out the requirements for the installation and commissioning of signal equipment including the controller, cabinet, vehicle and pedestrian signals, call boxes, detection equipment, and detector loops. It also addresses the painting of equipment.

The contractor warrants that:

- The equipment has been/will be installed in accordance with the manufacturer's instructions, all applicable laws and standards, and the reasonable instructions of the RCA,
- The equipment will not malfunction for a minimum period of as defined in Section 2.2.2, from the date of commissioning.

### 3.2 Temporary traffic management

The contractor shall be responsible for the supply and erection of all necessary barricades, warning notices, lights, and so on, as required under 5.7.2 of NZS 3910 and the *NZTA Code of Practice for Temporary Traffic Management*, or any other specific documents that may be provided by the RCA or client.

The contractor shall obtain from the RCA whatever approvals are required to be able to work on the roadway under the RCA's control.

### 3.3 Supply of electric power

The contractor shall be responsible for arranging, with the RCA's power supply company, the provision of a power meter (if required) and the switching on of power to the signal control cabinet. The contractor shall pay all costs (including fees) associated with this work, obtain all necessary permits, and shall provide the certificate of compliance to the engineer on completion of the works.\*Please note these costs can be variable, and need to be addressed by the primary contractor.

### 3.4 Waterproofing

All equipment below ground level shall be constructed and treated to permit continuous operation without fault due to immersion in ground water or other corrosive agents commonly encountered on or beneath roads.

### 3.5 Electrical wiring

All electrical work shall be completed in accordance with AS/NZS 3000.

#### 3.5.1 Pole top cable terminations

All cables shall be brought up the interior of the signal pole or mast arm, and terminated on the specified terminal assemblies. All cables shall be firmly supported at the point of termination in such a manner that the weight of the cable shall not impose mechanical strain on the electrical connections.

The cores of each cable are consecutively numbered on the core insulation and each core shall be terminated into the terminal labelled with the same number.

Where a 36 core cable is not used (generally in existing installations), and there is more than one cable coming into a pole, then the largest cored cable or cable labelled 'A' (see Section 4.8) shall start at terminal 1 with the smaller cables following on. For example, with a 25 plus a 12 core cable, core 1 of the 25 core will be terminated into terminal 1 with core 1 of the 12 core terminating into terminal 26. It is not necessary to label each core when using a single multi core cable and when each core terminates in its corresponding terminal. However, when two or more cables are terminated all cores shall be labelled.

The cable sheath shall be removed for an adequate length with due precautions being taken not to damage the insulation of the individual cores. The cable cores shall be neatly formed and laced to allow individual conductors to be connected to the appropriate numbered terminal in accordance with the approved cable termination chart (see Appendix F for example). The cores of different cables shall not be laced together.

The bunching and tying of cores shall be arranged such that all terminal labelling remains visible, and individual cores may be conveniently disconnected from any terminal for subsequent maintenance. All cable cores, including spares, shall be allocated terminals, and shall be terminated within the pole top.

### 3.5.2 *Earthing (bonding)*

All metal components shall be individually earthed in accordance with AS/NZS 3000, using a minimum size earthing cable of 4.0 mm<sup>2</sup>. Particular attention should be given to poles (including mast arms), callboxes, finial caps, metal bodied signals, unused cable cores, controller and cabinet, mast arm termination box, and audio tactile driver box.

All unused cable cores shall be bonded to earth in the controller cabinet.

### 3.5.3 *Cable termination chart*

For all new installations, a cable termination chart (see Appendix F for example) shall be completed prior to termination of cables onsite and supplied to the RCA Traffic Signal Engineer.

At existing sites, the contractor shall amend the existing cable termination chart supplied by the RCA. If no cable termination chart exists, the contractor shall be required to produce one from existing cable documentation as appropriate.

All cabling, both at the controller cabinet and at the pole, shall comply with the details of the cable termination chart.

## 3.6 **Controller cabinet**

The controller cabinet shall be securely fixed to a concrete foundation or preformed base with, at minimum, four hot dipped galvanised bolts (minimum size M12) such that the cabinet is aligned true to the vertical and cannot be rocked from side to side. Where a standard preformed base is not to be used, the foundation details shall be supplied to the RCA Traffic Signal Engineer for approval.

Where the cabinet is not surrounded by concrete or asphalt, a 300 mm wide concrete apron shall be provided around the base of the controller. The apron shall be 100 mm thick and be widened to 900 mm on the side adjacent to the door. The apron shall be installed to provide drainage away from the controller to the adjacent ground and to maintain a comfortable working platform.

## 3.7 **Controller terminations**

All cables entering the controller cabinet shall be securely supported at their outer sheath to ensure that no mechanical strain is transmitted to the electrical connections. The individual cores shall be neatly formed, and positioned such that access to housing terminals is not obstructed and terminal designations are not obscured. Each cable shall be individually labelled in accordance with its designation as shown on the approved cable termination chart.

All field wiring terminals in the controller cabinet shall be vertically mounted with sufficient terminals to cater for the maximum number of signal group outputs within the logic rack. Each signal group (both pedestrian and vehicle groups) shall be provided with three terminal groups. Each group shall consist of two 2-in/2-out spring loaded screw locked terminals designed for 2.5 mm<sup>2</sup> cable.

Terminal separation plates shall be used between each signal group and end clamps shall be used at each end of the rail.

An additional non-switched terminal unit shall be used and located on the left-hand side of the gear plate. This unit shall include three terminal blocks for both earth and neutral, plus one separate terminal block for general purpose (GP) phase (wired through the GP circuit breaker), detector returns, pedestrian buttons, special inputs and outputs, and so on.

The terminals shall be grouped together with the earth and neutral at the bottom, then any 230 V supplies and then the low voltage supplies at the top. A terminal separation plate shall be used between the earth and neutral terminals and between the 230 V and low voltage terminals.

Each terminal shall be clearly labelled with its function using labels supplied by the terminal manufacturer. There shall be a schematic wiring diagram provided within the controller (generally on the inside of the controller door) it shall provide a true representation of the physical on site wiring configuration.

### 3.8 External vehicle loop detector units

For all new signal installations, the detector units shall be located in the controller cabinet.

In special cases, or where an existing installation is involved, detector equipment may have to be accommodated in the weatherproof boxes attached to the signal pole nearest to the loop. Attachment of detector units to poles on medians or small islands shall be avoided as far as practicable. Pole-mounted detector units shall be mounted in an unobtrusive manner so that convenient access can be obtained to them from a ladder placed on the footpath.

The power supply for all detectors that are mounted external to the controller shall be taken from a 230/240VAC source that is not interrupted by the master relay when the controller is entering in lamp active off mode, for whatever is the reason (commissioning, fault, etc) in order to keep the detection active for SCATS coordination.

The connection of the loop feeder cable to the detector rack shall be carried out through terminals to allow easy isolation of the loop/loop feeder side of the circuit for testing purposes. The terminals shall be suitable for low voltage and therefore standard disconnect terminals are not appropriate. The terminals should preferably be mounted vertically down the left-hand side of the gear plate. The terminal rail shall be long enough to mount sufficient terminals for 24 detectors.

The terminals shall be labelled with the on-street detector number.

The loop feeder shall be securely clamped with clamping bars to the gear plate so that no strain is placed on the core conductor.

### 3.9 Pole (post) locations and installation

All poles shall be sited in accordance with the approved design drawing with the appropriate clearances.

Prior to installation, the pole locations shall be marked on site and their locations approved by the RCA Traffic Signal Engineer. Where services are suspected potholes should be dug to confirm the locations are viable prior to requesting RCA approving. When requesting approval for poles mounted with pedestrian call boxes, both sides of the crossing should be approved together. Potholes can be temporarily reinstated if necessary.

Poles are to be positioned to ensure that no part of the signal lantern or backing board is closer than 300 mm to the face of the kerb or possible vehicle body track considering the road camber

Where not surrounded by concrete or asphalt, the pole shall have a 500 mm<sup>2</sup>, 150 mm deep, 20 Mpa concrete surround. The concrete surround shall be sufficient in width to

ensure that the ducting finishes within the area of the concrete, in order to protect all cabling. (See Appendix D.)

### 3.10 Signal lanterns

#### 3.10.1 *Lantern mounting supports, brackets and straps*

All lantern mounting brackets, bolts, nuts, and mounting hardware shall comply with Section 6 of AS2339:2017.

All lower lantern nut and bolt assemblies shall be installed complete with a locking mechanism as detailed in 6.2.3 of AS2339:2017.

One such acceptable method is to comply with the locking mechanism as detailed in Appendix N.

Where more than a single column of lanterns are installed on one strap back to the pole, each end of the strap must have a locking mechanism fitted.

Each vehicle/pedestrian lantern group shall be mounted individually.

All signals attached to pole top assemblies shall have their leads securely fixed to the assembly using clamping bolts, nuts, and washers or studs not less than 10 mm in diameter.

Each signal lantern shall be attached to its mounting brackets by galvanised steel mounting straps of sufficient length to permit the lantern to be adjusted laterally to provide an adequate signal indication and vertically to conform to the approach gradient. Straps shall comply with Table 1.

**Table 1 – Lantern mounting strap dimensions**

Strap length (mm)	Strap thickness (mm min)
Up to 150	3
151 to 250	5
251 to 400	6

Straps shall be in a continuous length without joints, and one strap shall not be hung off another strap.

#### 3.10.2 *Lantern leads*

The lantern leads shall:

- (a) Be covered with a continuous 15 mm flexible hose from their exit point from the lantern to the clamping point on the UMB;
- (b) The pole-connecting end of the hose shall be prepared so as to enable it to be firmly clamped in a recess in the pole top assembly without undue distortion or crushing of the hose;
- (c) When hanging freely, the lantern lead shall extend down to approximately the halfway point of the lantern.

#### 3.10.3 *Siting of signal lanterns*

##### 3.10.3.1 *Siting and alignment*

Each lantern shall be sited and aligned in accordance with Austroads publication *Guide to Traffic Engineering Management Part 10 – Traffic Control and Communication Devices*.



### 3.10.3.2 *Lantern mounting height*

Except where the tertiary or secondary lanterns are mounted within 10 m of the vehicle limit line, all vehicle lanterns shall have a mounting height of 4.1 m, measured to the top mounting bracket of lantern.

Where low level tertiary or secondary signal lanterns are located within 10 m from the vehicle limit line, the mounting height shall be 3.1 m, measured to the top of the mounting bracket of the lantern.

The minimum clearance from ground level to the bottom of a target board for signals restricted by an overhead obstruction is to be 2 m.

The minimum clearance from the road surface to the bottom of the target board for overhead lanterns is to be 5.3 m. The maximum clearance is to be 5.8 m.

Where the position of the signal poles as installed does not allow the recommended positioning or appropriate visibility to be achieved, the contractor shall notify the RCA Traffic Signal Engineer before installing the lantern.

### 3.10.4 *Covering of lanterns*

Immediately following installation and during periods when the lanterns are not in use they shall be securely covered to completely obscure them while being installed or when not in use.

The lanterns shall be covered using a shroud as detailed in Appendix E.

Where commissioning will take place within one day of lantern installation, the engineer may allow a dispensation from this requirement but otherwise shrouding shall be necessary for the full period from installation until commissioning.

## 3.11 Inductive loops

Inductive loops shall be positioned to record the specified output from vehicles passing or occupying the positions indicated on the appropriate plans and to the dimensions and locations shown in Appendix A.

The contractor shall mark the required position of the inductive loop on the ground and inspect the road surface to ensure that the site conditions, including seal conditions and roadway integrity, will in no way reduce the operational performance of the detection equipment. If the contractor considers that the conditions are not satisfactory, they shall notify the RCA Traffic Signal Engineer before installing the detector loops. The contractor shall notify the engineer prior to closing the traffic lanes for the purpose of installing the loops so that the engineer may attend the site to carry out the installation inspections that they consider appropriate.

The inductive loop wire shall consist of single core polypropylene insulated cable with a nominal cross-sectional area of 1.5 mm<sup>2</sup> complying with AS/NZS 2276.3.

The cable shall be laid in one continuous unjointed length, laying it twice around each loop as shown in Appendix A. Tails for up to two loops, (four wires) may be laid in the same slot if required. Note as required in Appendix A and to permit future use under SCATS or to allow the loops to be split in the event of damage, the front pair and back pair of loops should be wired with a connecting wire passing through the toby box. This connecting wire shall remain continuous and shall be approximately 0.8m in length.

In general, the detector loop wire shall be installed in a saw cut slot that is approximately 5 mm wide and 40 mm deep to provide a minimum top cover to the wire of 12 mm. All saw cuts shall be straight and shall extend past the loop corners to ensure the full depth of cut throughout. Prior to placing the loop wire, the slot shall be dried and cleaned and free of debris to provide a smooth bed for the wire. The recommended method of doing this is with compressed air.

If unable to reuse the existing saw cut when re-cutting loops, the new saw cut shall be at least 300 mm away from the old saw cut to minimise road surface damage. If the saw cut for the loop tails is to go through the kerb, then it should go through an existing mortar joint to minimise unsightly appearances.

The loop wire shall be 'rolled' into the slot without damaging the insulation. This can be achieved using a thin disc such as a modified saw blade but not a screwdriver. Special care shall be taken at the corners to ensure the wire is curved rather than bent. Each loop shall be wired as shown in Appendix A.

Immediately following the installation of the loop wire, and prior to sealing, an insulation resistance test shall be performed. The loop should have a resistance to earth of not less than 10 mega-ohms. Sealing shall be done immediately following the completion of the loop insulation test.

The loop wire slot shall be sealed with an approved flexible epoxy sealant, ensuring a continuous seal over the complete length of the loop and loop tails. The sealant shall be finished flush to the road surface and suitably sanded.

Where the loop tail is cut through the kerb and channel the tails shall be inserted in a saw cut slot that is approximately 5 mm wide made with a minimum 450 mm diameter blade. The saw cut kerb and channel shall be sealed with a sand cement mortar.

Due to noise and traffic flow conditions, the RCA or client may restrict the time at which detector loops may be installed.

### **3.11.1** *Loop testing*

All loops shall be tested by measuring the insulation to ground (earth) and the results recorded on the commissioning sheet. A 500 V test shall be taken from the isolated conductors down to earth and a result of not less than 10 megaohms will be acceptable.

The loops should have a minimum Q value of 15 when measured in the KJB.

### **3.11.2** *Saw cutting*

The contractor shall ensure that no solid matter enters any waterway as a result of the saw cutting operation. This could require the placement of filters, or similar, on catchpits, and so on.

On completion of the installation the contractor shall ensure that the surrounding area is swept clean of all sand and debris. This material shall be suitably disposed of.

Preformed loops shall be installed according to the manufacturer's details and retain the correct shape and dimensions as shown on Appendix A when installed.

### **3.11.3** *Loop feeder connections*

Where multi-pair feeder cable is used, the convention for terminating the loops shall be:

- (a) Pair 1 connected to the kerbside detector loop;
- (b) All remaining connections numbered consecutively from the kerb.

All unused pairs shall be sealed in a similar method to the loop connections.

The contractor shall make a clean, dry, waterproof electrical connection between the loop tails and the loop feeder wires. The connection shall be located within a kerb side junction box or nearby prescribed junction point. The feeder cable sheathing shall be sealed to ensure that no water may enter into the cable.

### **3.11.4** *Cycle induction loops*

The controller hardware specification was not designed for accurate detection of modern bicycles or personal mobility devices. Care must be demonstrated when installing cycle induction loops as there are a lot of factors that affect the loops oscillation performance,

like: shape, dimension, cable type, cable size, cable length as well as the properties of the feeder cable, however key to all these is to ensure that each loop contains a sufficient wire length to create a detectable flux change for the detector card to read. 24m of cable within the loop is deemed the minimum, this can require six or more turns of cable within a loop.

Once installed the sensitivity adjustment is the only adjustment to allow a user to fine tune cycle detection. The maintenance engineer should utilise an aluminium wheel in order to test cycle loops, The maintenance engineer should ensure that the sensitivity is not set so high as to be triggered by vehicles in adjacent lanes.

### 3.12 Pedestrian and cycle push button assembly

The push button assembly shall be mounted so that the underside of the assembly is 900 mm above the pavement.

Unless specifically detailed, the pedestrian assembly shall be located in accordance with Section 5 of RTS 14, that is, so that the front of the assembly is perpendicular to the pedestrian crossing lines and so the arrow disc will always be orientated with the arrow pointing straight up.

On non-staggered medians, the assembly shall be oriented parallel to pedestrian lines with a double headed arrow disc that has the arrow pointing parallel to the ground.

The cycle assembly should be located so that the front of the assembly is perpendicular to the pedestrian crossing lines, where this is not possible refer to the local RCA Engineer.

Wiring for the call-accept is required for cycle call boxes.

### 3.13 Painting and surface coating of equipment

All surface coatings shall carry a 10-year guarantee from their date of installation except where the degradation is caused by vandalism.

The contractor shall supply the RCA Traffic Signal Engineer with the paint manufacturers' documentation specifying the maintenance requirements for surface-coated equipment.

All painting of signal poles and equipment shall be as in Table 2.

**Table 1 – Painting and surface coating of equipment**

<b>(A) GENERAL REQUIREMENTS</b>	
<ul style="list-style-type: none"> <li>• All new poles shall be pre-coated prior to delivery on site</li> <li>• All coatings shall be applied in strict accordance with the manufacturer's recommendations</li> <li>• No painting shall be carried out in wet, foggy, frosty, windy, or dusty weather</li> <li>• The colour yellow described in this specification shall be colour number Y14 Golden Yellow as described in AS2700 (Altex Standard Factory Colour Golden Yellow is acceptable).</li> </ul>	
<b>(B) PAINTING SCHEDULE</b>	
<b>Standard poles</b>	Gloss yellow to the pole top, or as specified in the local RCA's regional amendments to NZS 5431.
<b>Overhead and joint use poles</b>	Unless specified in the local RCA's regional amendments to NZS 5431, all overhead or joint use poles shall be painted gloss yellow to the level of the top mounting bracket supporting the low level vehicle lantern. The remainder of

	the pole is to be left unpainted.
<b>Lanterns:</b>	
Signal face	Gloss black
Signal housing	Gloss black
Target boards	Flat black
Signal visors	Flat black (internally) Gloss black (externally)
<b>Illuminated signs:</b>	
Sign face	Gloss black
Sign housing	Gloss black
Sign visors	Flat black (internally) Gloss black (externally)
<b>Pedestrian call boxes</b>	Gloss black
<b>Cycle call boxes</b>	Gloss blue – Dulux “True Blue” shade 2821 or equivalent
<b>Other items</b> (such as pole caps, detector boxes)	Golden Yellow or as specified by the local RCA’s regional amendments

### 3.14 Special tools and keys

The contractor shall supply to the RCA Traffic Signal Engineer one set of any special tools necessary to efficiently adjust and operate the equipment. This equipment will not be required if previously supplied to the RCA. The controller key type will be an FS880 or as specified in the local RCA’s regional amendments.

### 3.15 Acceptance and testing

On completion of the work, the equipment is to be left clean, free from dirt, dust, and paint blemishes. All services, equipment, and fittings shall be in proper working order and in good condition in accordance with this specification.

#### 3.15.1 *Pre-commissioning tests*

When the contractor has satisfied all of the requirements of the power supply authority, and considers that any particular part of the contract is ready for commissioning, the pre-commissioning checks as set out in the site acceptance sheet in Appendix G shall be performed in the presence of the RCA Traffic Signal Engineer or their representative.

The contractor shall provide an electrical certificate of compliance to the engineer prior to the pre-commissioning check.

#### 3.15.2 *Earthing and earth impedance test*

The contractor is to undertake an earth impedance test to AS/NZS 3000 and submit results in a report as part of their pre-commissioning checks. The tests shall include the following:

- (a) Earth resistance test–continuity of main earth conductor;
- (b) Insulation resistance test for insulation;
- (c) Earth resistance test for other earthed and equipotential bonded parts;
- (d) Consumer’s main test – polarity and connections;
- (e) Final sub-circuit test – polarity and connections;
- (f) Earth fault loop impedance test; and
- (g) Verification of residual current devices (if fitted).

#### 3.15.3 *Software (personality) Testing*

The Software is to undergo a series of tests and to be signed off at each stage by a competent software engineer

The CIS is to be independently reviewed a signed off prior to the software being written.

Once the software is written it is to be independently tested with a traffic signal software emulation program e.g. Win Traff and signed off to ensure compliance with the CIS.

The sft files are then able to be supplied to the contractor to create the PROM for bench testing

Where the software is generic, such as a pedestrian crossing, and with the RCA Traffic Signal Engineer's acceptance, the process can be undertaken without independent review.

#### **3.15.4** *Controller bench test*

The contractor shall be required to confirm for themselves that the controller software (personality) has been programmed to operate in a safe manner and to the requirements of the design drawings and controller information sheet (CIS). If the contractor is of the opinion that the software is not operating correctly or safely, or there are discrepancies between the design drawings and the CIS, then they shall immediately inform the engineer.

The traffic signal contractor shall complete a FULL bench testing of the controller software (personality) at least 1 week prior to the proposed commissioning date of the signal installation or intersection upgrade.

All bench testing shall be based on the operation as specified in the latest revision of the CIS, signal design drawing, and controller software (SFT) file.

The bench testing shall be undertaken using a similar controller operating under the same version of the background (TRAFF) software as will be installed in the controller on site.

The bench testing shall include but not be limited to:

- (a) Confirmation that all detectors call and extend the relevant phases;
- (b) Confirmation that the correct signal displays/output groups are activated in the relevant phases;
- (c) Confirmation that each signal group output has been configured as either a Major, Minor, or Pedestrian output in accordance with the CIS;
- (d) Confirmation that all conflicting signal group outputs (both pedestrian and vehicle) cause the controller to go into fault mode by physically inducing conflicting outputs. The contractor shall be required to confirm that the conflict matrix detailed in the CIS is correct and that the conflict matrix programmed into the controller personality is the same as that shown in the CIS;
- (e) Confirmation that all time settings are consistent between the software and the CIS;
- (f) Confirmation that the controller will operate under Flexilink mode of control;
- (g) Confirmation that any special logic requirements work as specified; and
- (h) Confirmation that any special facility flags (such as Z- , Z+, and any XSF bits) operate as specified.

The contractor installing the software shall submit completed and signed forms 5 working days prior to commissioning the site verifying that the traffic signal controller personality has been FULLY bench tested. A copy of the controller bench testing form is in Appendix H.

The contractor shall notify the RCA Traffic Signal Engineer at least 24 hours prior to the bench testing being undertaken so that the RCA Traffic Signal Engineer may be present when the testing is being completed.

#### **3.15.5** *Commissioning*

When the RCA Traffic Signal Engineer or their representative is satisfied that the signals are installed and operating in accordance with this specification, they will direct and supervise the commissioning of the signals.

The contractor shall notify the RCA Traffic Signal Engineer 48 hours prior to commissioning the installation. Commissioning shall occur outside of the peak traffic periods at a time specified by the engineer. No commissioning shall take place on a Friday or the day before a public holiday.

Unless approved by the RCA Traffic Signal Engineer, commissioning will not be allowed until the controller has been installed on site and has had continuous SCATS communications for at least 48 hours.

An example of a commissioning check sheet for a new installation is in Appendix J.

### 3.16 As-built documentation to be provided

The contractor shall also supply in both electronic and hardcopy the following within 4 weeks of commissioning:

- (a) As-built plan showing the final locations of all cables (including power supply), ducting, poles, access chambers, KJB, loops, lantern displays, and cabinets if they are different from the construction drawing;
- (b) A completed cable termination chart (in spreadsheet format). A typical layout is shown in Appendix F;
- (c) A completed traffic signal asset collection form (see Appendix K) for RAMM;
- (d) Results of all earth loop impedance testing carried out on all traffic signal poles and cabinets shall be supplied to the RCA's engineer prior to commissioning (Appendix M). The results shall be signed by the technician who carried out the testing;
- (e) A log book. The log book shall be completed every time anyone attends site, and shall detail the reason for attending site and a brief description of the work carried out. Each entry shall be dated and signed; and
- (f) A copy of the electrical certificate of compliance.

At the time of commissioning, a copy of items (a) and (b) shall be provided in the controller cabinet along with a log book and a copy of the CIS. Within 2 weeks of commissioning, a laminated copy of (a), (b), and the CIS sheet shall be inserted into the document pocket inside the controller cabinet.

### 3.17 Procedure for turning off signals

Where it is necessary to switch a controller either off, to flashing yellow, to take the site off-line, or to switch the signal displays off, notice shall be given to the appropriate RCA. The RCA shall be notified immediately prior to such action being taken and immediately after the controller and communications are fully operational again. The fact that the signals were turned off shall be recorded in the control cabinet log book.

When a signalised intersection is planned to be turned off, or switched to flashing yellow, for more than ten minutes, the contractor shall ensure that the RCA's engineer is informed so that arrangements for alternative control of the intersection can be made as necessary. Once the RCA Traffic Signal Engineer has been notified, the contractor can proceed with turning off the signals, unless specifically requested to wait for further assistance.

When a signalised intersection is planned to be turned off (not flashing yellow) for more than 10 minutes, the contractor shall adhere to an approved traffic management plan (TMP).

At no time during planned works shall an intersection be left unattended with the signals off unless an approved TMP is in place. Also, at no time shall any warning signs or shrouds that indicate that the signals are not in operation be in place on any street or road when the signals are working.

When there is an unplanned outage of a signalised intersection (such as the result of a controller fault or accident), the contractor shall immediately assess the problem and where necessary make the site electrically safe. If the signals can then be repaired and made operational (either fully or at least flashing yellow) within 1 hour, and can be done so safely and without the need to work in a live lane, then the contractor is to proceed immediately with the repairs using a previously approved TMP that relates to the particular type and location of the work. Refer to RCA's regional amendments to P43 if operational repairs will take longer than 1 hour, or where work needs to occur within a live lane.

It should always be the intention of the contractor to arrange the work so that the signals will be switched off or set to flashing yellow for the shortest possible time. This will mean that wherever possible, work on the signals is to be continuous until they are switched back to normal control. If a site is under approved temporary traffic management (as set out in an approved TMP), then it will normally be acceptable to turn the signals back on with a reduced number of signal displays. Assuming good visibility of lanterns, the minimum number of displays on any approach can be:

- (a) Primary or dual primary plus secondary; or
- (b) Primary or dual primary plus tertiary.

The intention to operate the signals with reduced displays shall be highlighted in the TMP, which should detail each approach where displays will be reduced. The RCA's regional amendments to P43 may set out additional requirements.

## 4 CABLING AND CIVIL WORKS

### 4.1 General

Section 4 sets out the requirements for the supply and installation of all cabling including multicore cable, loop feeder cable, ducting, trenching, and backfilling. It also addresses the installation of kerbside junction boxes, poles, and the controller base.

### 4.2 Cable diagram

Cable sizes and approximate duct positions can be found on the schematic cable diagram on the signal drawing but the contractor should confirm that the cabling and ducting shown is adequate for the signals equipment depicted on the same drawing.

### 4.3 Trenching

All trenching and restoration work shall be in accordance with the RCA's specification. A detailed TMP shall be approved before work commences.

Open cut trenching across carriageways shall be carried out only between the hours approved by the engineer.

### 4.4 Cabling, ducting, and signal duct access chambers

#### 4.4.1 *Ducting*

Ducting shall be installed from the controller to all signal duct access chambers, between chambers, and from the chamber to the signal pole in the locations indicated on the drawings.

The duct lines shall link all chambers in a complete ring to facilitate multiple cable run options.

In open cut trenching, ducting for all multi-core cables shall use 100 mm diameter orange PVC electrical burial-grade conduit, and shall be continuous between access chambers and from access chamber to within 300 mm of the base of each pole. The ducts shall be placed no less than 600 mm and no more than 1000 mm below finished ground level.

All thrust ducting shall be continuous without any joints and shall comply with the Electricity (Safety) Regulations.

The minimum number of ducts from the controller and between access chambers is two x 100mm ducts.

All ducting is to be installed complete with draw wires to facilitate pulling through of cables. The draw wire will remain in place on completion of cabling for future use and must always be replaced when used.

Ducting for loop feeder cables shall be a minimum 50 mm diameter orange PVC electrical burial-grade conduit laid to a depth of not less than 300 mm and where provided directly behind the kerb. It shall be continuous between the KJB and the closest access chamber.

Where ducting pipes need to be joined, they shall be jointed with approved PVC cement.

Communications ducting should comply with the local RCA's requirements.

#### 4.4.1.1 *Pole access ducting*

Access from the ducting to the signal pole for ground plant or flange mounted poles shall be as shown in Appendix D.

#### 4.4.2 *Signal duct access chambers*

Signal duct access chambers are to be provided at all 230 V cable duct intersection points and at either end of sub-carriageway ducting as shown on the signal drawing. Where



possible, chambers are to be at least 2 m clear of the carriageway and clear of all pedestrian paths. A chamber is also to be provided immediately adjacent to the controller base.

Chambers are not to be located along pedestrian desire lines.

Chambers shall not be installed in the carriageway,

All duct access chambers shall be concrete and manufactured in accordance with NZS 3109 and AS/NZS 4058, with surfaces finishes to NZS 3114, Where contractors have chambers manufactured from alternative materials, they shall seek prior written approval from the RCA Traffic Signal Engineer before tender/installation.

All ducting shall be cut back to the chamber wall and shall be sealed by applying a sand cement or epoxy mortar.

All covers are to be a minimum Class B as defined in AS 3996. Any chamber lid that is subject to possible traffic loading or installed in the carriageway are to be Class D.

Where the chamber is installed in a grassed berm, the lid of the chamber shall be encased by a concrete surround, a minimum of 300 mm wide by 100 mm deep and using 25 MPa concrete.

#### 4.4.3 *Signal multi-core cable*

All cable shall be installed in the appropriate ducting as specified in Section 4.4.

The multicore cable shall be a purpose designed traffic signal cable externally insulated with orange sheathing with the internal individual core insulation being PVC coloured as described below. The external sheathing shall be marked to indicate its use in the installation of traffic signals. The cable shall comply with AS/NZS 2276.1 except as amended in Section 4.4.3.1.

The cable shall be in a continuous length from the controller to the pole and from pole to pole. Joints between poles will not be accepted in new works. A minimum of 2.0 m of cable slack shall be left at the controller base and a minimum of 1m in the chambers on all cable runs.

At existing installations where cable is to be replaced, similar cabling and cores as are already installed may be used.

Cabling shall not be installed into the ducting until backfilling of trenches has been completed.

##### 4.4.3.1 *Amendments to AS/NZS 2276.1*

The following amendments shall be made to AS/NZS 2276.1:

- a) Remove requirement for external sheathing to be PVC. The sheathing used shall be suitable to be used in submerged conditions;
- b) Cable core requirements and colours
  - i. 27 1.5 mm<sup>2</sup> cores coloured white and consecutively numbered from 1 to 27 for signal group displays;
  - ii. 1.5 mm<sup>2</sup> cores coloured violet, labelled 'ELV ONLY' and consecutively numbered p1, p2, p3, p4;
  - iii. 1 2.5 mm<sup>2</sup> core coloured black;
  - iv. 1 4 mm<sup>2</sup> core coloured green/yellow for earth;
  - v. 1 red 1.5 mm<sup>2</sup> core as a general 230 V phase (for audio tactile, illuminated signs, cameras, and so on);
  - vi. 1 grey 1.5 mm<sup>2</sup> core detector return for push buttons;
  - vii. 1 orange 1.5 mm<sup>2</sup> core used for street lighting feed.

#### 4.4.4 *Loop feeder cable*

The feeder cable shall be a twisted pair and be terminated on the appropriate field terminals.

The maximum number of pairs per cable is four (4). If multi-pair cable is used then each pair should be labelled with factory indelible numbering on the cores, or colour coded as detailed below:

- Pair 1 – Blue and white/Blue
- Pair 2 – Orange and white/Orange
- Pair 3 – Green and white/Green
- Pair 4 – Black and white/Black

Cable pairs must be individually shielded.

All spare pairs are to be separated away from active pairs and all shield braids shall be connected to a common protective earth point.

The unshielded section of the feeder cable pairs shall remain twisted from the point they leave the cable shield to where they enter into the field terminals with the length of unshielded cable being as short as possible. All shields shall be connected to a single common functional earth point at the controller.

The feeder cable shall comply with AS/NZS 2276.2, except pairs shall be colour coded as above, and the overall external diameter will exceed 10mm. This is to allow the use of multi-pair loop-feeder cables.

At least 1.8 m of cable slack shall be left at the controller base, one turn in each access chamber and a minimum of 0.5 m curled up inside the kerbside junction box (KJB).

##### 4.4.4.1 *Loop feeder cable testing*

All feeder cables shall be tested by measuring the insulation to ground (earth) and the results recorded on the commissioning sheet. A 500 V test shall be taken from the isolated conductors down to earth and a result of not less than 10 megohms will be acceptable. The resistance of the feeder cable and connected loop, when measured at the controller, shall be no more than 10 megaohms.

#### 4.4.5 *Mains power supply*

The contractor shall be responsible for negotiating with the local electricity network provider for the supply of a mains power cable into the signal control cabinet.

#### 4.4.6 *Earthing*

The earth pin and wiring connection shall be located in a protected enclosure not readily accessible to the public.

#### 4.4.7 *Fibre*

Running fibre through signal access ducts should be avoided and if this is required confirmation shall be sought from the RCA Traffic Signal Engineer.

### 4.5 **Installation of signal poles and mast arm/JUMA/JUSP poles**

Signal poles shall be erected as detailed in Appendix C. Each pole is to be plumbed vertically to a tolerance of 10 mm per 5.0 m length.

For poles up to 5 m, all concrete footings shall have a 28-day compressive strength of at least 20 MPa. Footings for all other poles shall be as per the manufacturer's pole foundation design requirements.

Signal poles shall be in locations shown on the signal plan. These locations are only indicative and final locations will need to be marked out and agreed to with the RCA Traffic Signal Engineer. The RCA Traffic Signal Engineer shall approve any changes to the designed pole positions. Due to the requirement to ensure push buttons are within tolerance of the cross walk it is advisable to pot hole all the poles for a pedestrian crossing for approval before installation to minimise the impact of utilities. Pot holes are to be temporary reinstated following inspection and approval, temporary board covers are not acceptable where pedestrian access is permitted.

For traffic signal installations on heavy haulage routes, any signal poles in central islands, or poles that restrict the width to below the heavy haulage route requirements, shall be fold down type as detailed in figure C5 or C6 in Appendix C.

The contractor shall confirm on site that the location of all poles meets the clearance requirements to existing electrical supply services, both underground and overhead, as set out in NZECP 34.

#### **4.6 Controller base**

The controller base shall be constructed to provide a solid non-rocking platform on which the controller may be placed.

The base shall be constructed using reinforced concrete with a 28-day compressive strength of 20 MPa.

The RCA Traffic Signal Engineer or their representative will mark the exact position of the base on site.

#### **4.7 Kerbside junction boxes**

Kerbside junction boxes (KJB) shall be constructed from plastic, cast, or sheet aluminium and shall be no smaller than 300 mm long by 200 mm wide by 150 mm deep.

The KJB shall be fitted with a firm fitting non-skid lid secured to the base and the lid shall lie flush with the top of the box.

Each KJB shall be installed at the locations indicated on the drawing. Where possible they should be located adjacent to the primary signal pole. The KJB shall be as close as possible to the back of the kerb and shall be level with the surrounding ground surface level.

Where there is no concrete kerbing present the KJB shall be located as close as practicable to the carriageway.

KJB shall be bedded on 100 mm of free draining material and surrounded by 150 mm wide by 150 mm deep concrete haunching and the junction box lid and haunching shall be flush with the surrounding ground level.

The junction box and installation shall be capable of withstanding being run-over by a heavy vehicle.

#### **4.8 Labelling of cables**

All multicore cabling shall be clearly labelled at both ends with the cable run number. The cable shall be numbered so that cable 1 goes to pole 1, cable 2 goes pole 2, and so on. When there are two or more identical cables laid between poles, one cable shall have its label followed by the letter A (for example, P6A) which shall have terminal numbers starting at 1. The second cable shall be labelled B (for example, P6B) and start at the next available terminal, and so on.

All loop feeder cable shall be labelled at both ends with the appropriate detector loop number.

The approved method for labelling all cables is using a heavy duty PVC marker, white or yellow with black moulded or engraved lettering. This marker is to be of the non-split type that completely encircles the cable core.

## **4.9 Cabling documentation**

All new or modified traffic signal ducting and cabling is required to be recorded for inclusion on the appropriate RCA cable diagram.

Any contractor installing or modifying traffic signal ducts or cables shall notify the RCA Traffic Signal Engineer a minimum of 24 hours prior to backfilling any trenches in which new or modified ducts/cabling have been installed so that the cables can be independently sighted and recorded. No inspections will be carried out outside of normal working hours except by prior arrangement with the RCA Traffic Signal Engineer.

## **5 MAINTENANCE OF NEW WORK DURING DLP**

### **5.1 Fault attendance**

All callouts to faults reported during the contract's defects liability period (DLP), while the installation is under maintenance, or during the equipment guarantee period shall be attended by the installing contractor or their delegated sub-contractor.

While the installation is in the DLP, or similar periods, the contractor who installed the signals (installing contractor) shall be required to provide the contact details of a suitably qualified technician who is contactable 24 hours per day and 7 days per week to resolve faults. The response time to a priority 1 (emergency) fault by the installing contractor or their delegate will be no more than one hour. All other faults will have a response time of no more than 24 hours, Monday to Friday 0900 to 1700hrs.

The installing Project will be responsible for ensuring that the contractor is suitably compensated for repairing any faults due to accident or vandalism during DLP. It is therefore in the Projects best interest to expedite project completion for the signals assets and therefore minimise their risk.

In the event that the RCA sends the maintenance contractor to attend to a fault due to the installing contractor being unable to fulfil their obligations, any costs incurred by the maintenance contractor for faults attended during the DLP will be reimbursed by the Project.

At the end of the DLP/guarantee period, the equipment shall be handed over in full working order with no defects of any kind. Should defects exist, whether in control equipment, detectors, or signal hardware or in any part of the equipment supplied, these shall be made good by the Project at no cost to the RCA.

### **5.2 Preventative maintenance during DLP period**

It will be the responsibility of the Project to arrange any preventative maintenance during DLP. As a minimum, preventative maintenance should be undertaken by the installing contractor within a month of the scheduled hand over to maintenance. Records of this maintenance will be provided to the RCA's Traffic Signals Engineer at hand over as evidence of the asset condition.

# APPENDIX A – INDUCTIVE LOOP LAYOUT DETAILS

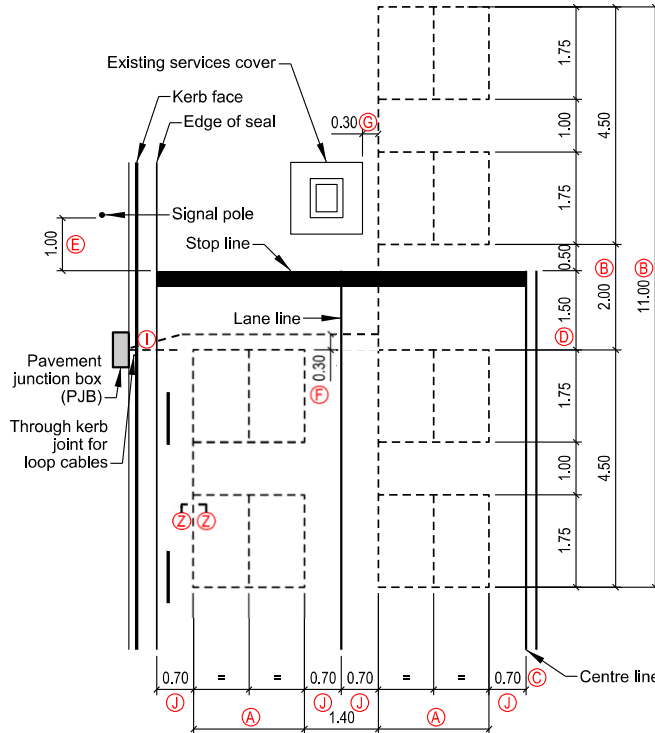

**Standard 4.5m Stopline Loop With Right Turn Call Loop**

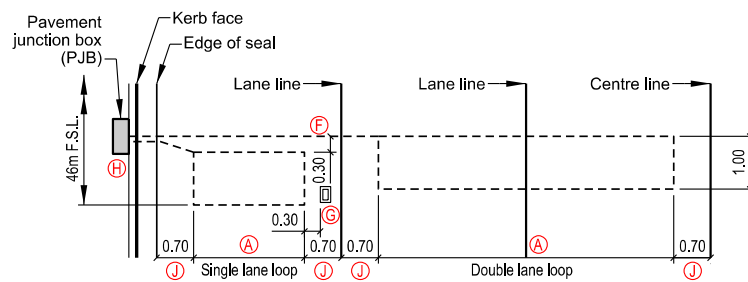

**Advance Loop**

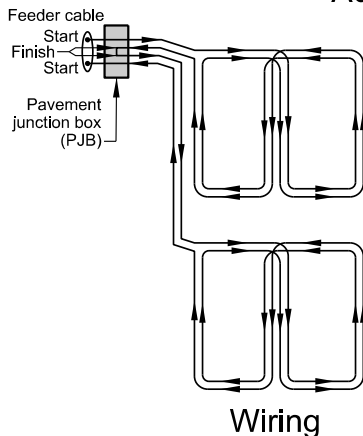

**Wiring**

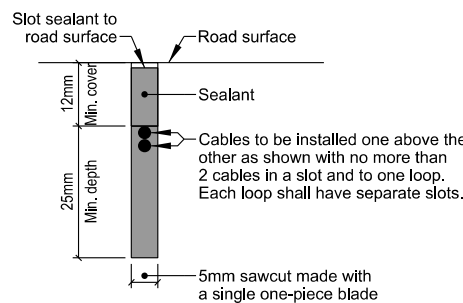

**Existing Road Surfaces Section Z-Z**

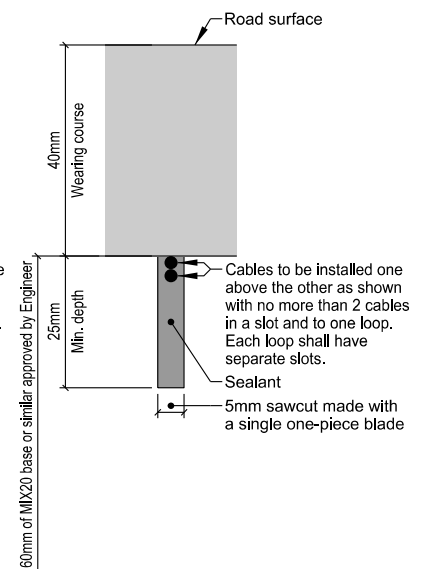

**Newly Constructed Road Surfaces Section Z-Z**

**Notes:**

- (A) Dimension derived from the lane width stated on the design plan.
- (B) Distance between the loops will depend on geometry layout and right turn filtering position of vehicle.
- (C) 0.7m distance to be 0.5m when the loop and lane is separated more than 0.5m using for example a median or painted lines
- (D) Distance 1.5m from stop line (F.S.L.) unless otherwise stated on the design plan.
- (E) Distance between 1.0-3.0m from primary pole location unless otherwise stated on the design plan. Where no details have been supplied it shall be 1.0m.
- (F) Feeders shall all be in separate slots, one slot per loop pair to kerb face and be a minimum of 0.3m apart from other slots.
- (G) Service covers shall be at least 0.3m from any loop cable slot.
- (H) As built information to show locations of loop feeder cables in relation to the site equipment including pole, kerb faces, medians, service covers, distance to the stop line shall be recorded on the as built in metres from stop line (F.S.L.) to start of loop.
- (I) Through kerb joint using minimum 405mm concrete saw, wire shall have minimum 12mm cover and be sealed the same as detector loops.
- (J) Offset loops 0.7m from the road lane markings adjacent to the loop, where lane loop is adjacent to kerb face use edge of seal to offset 0.7m to loop.

**Wiring Rules:**

1. Mark 'start' at end of cable.
2. Start of in a clockwise direction on entry from kerb face.
3. Form two 'figure 8' patterns for each loop section.
4. Change direction at the centre (longitudinal) cut to make a 'figure 8' pattern.

**Figure A01 – Vehicle loop details**

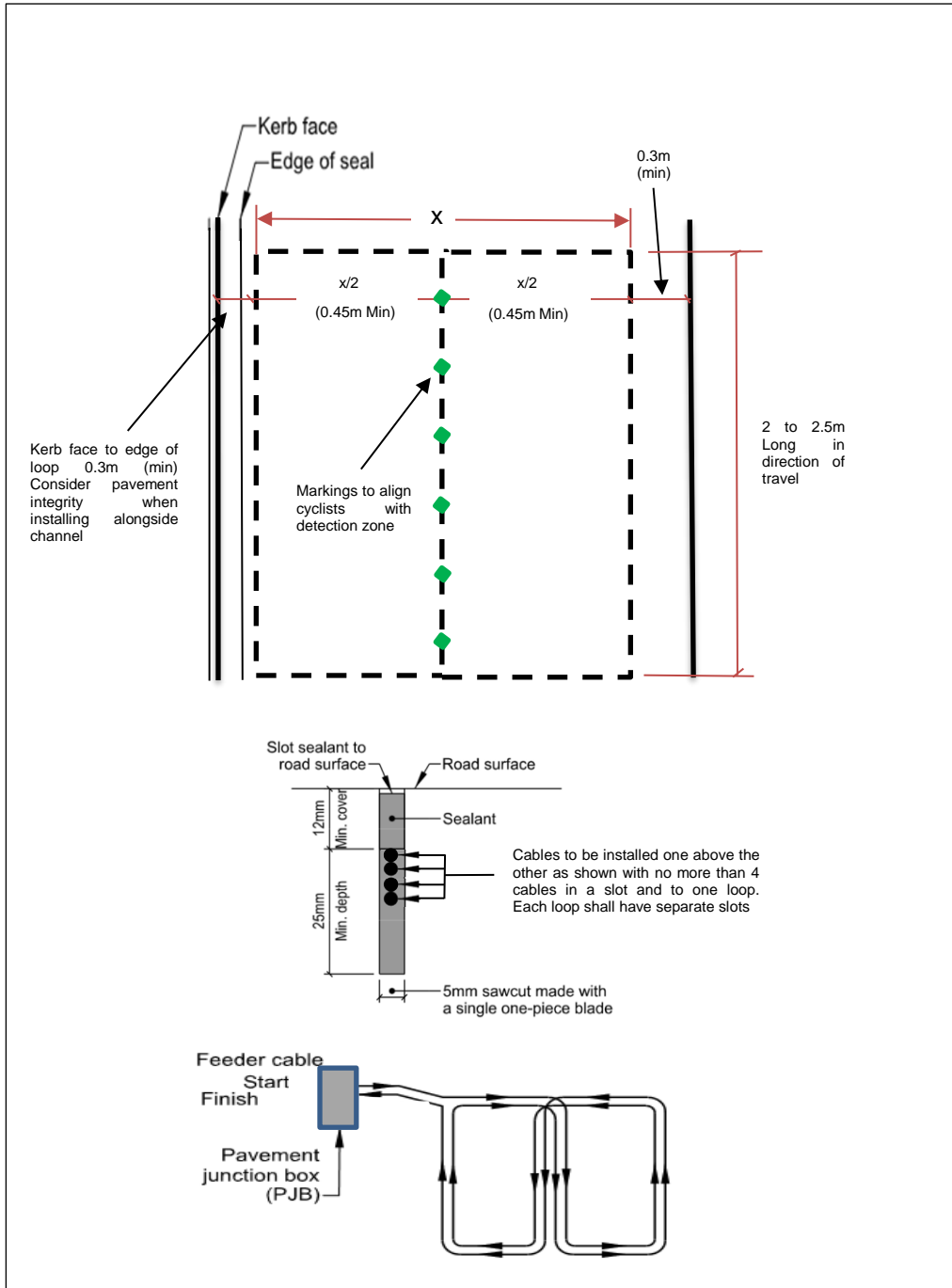

**CYCLE LOOP CABLE DETAIL**

Figure A02 – Cycle loop details

# APPENDIX B - 5 METRE POLE TOP ASSEMBLY

## Figure B01 - Pole Top Assembly

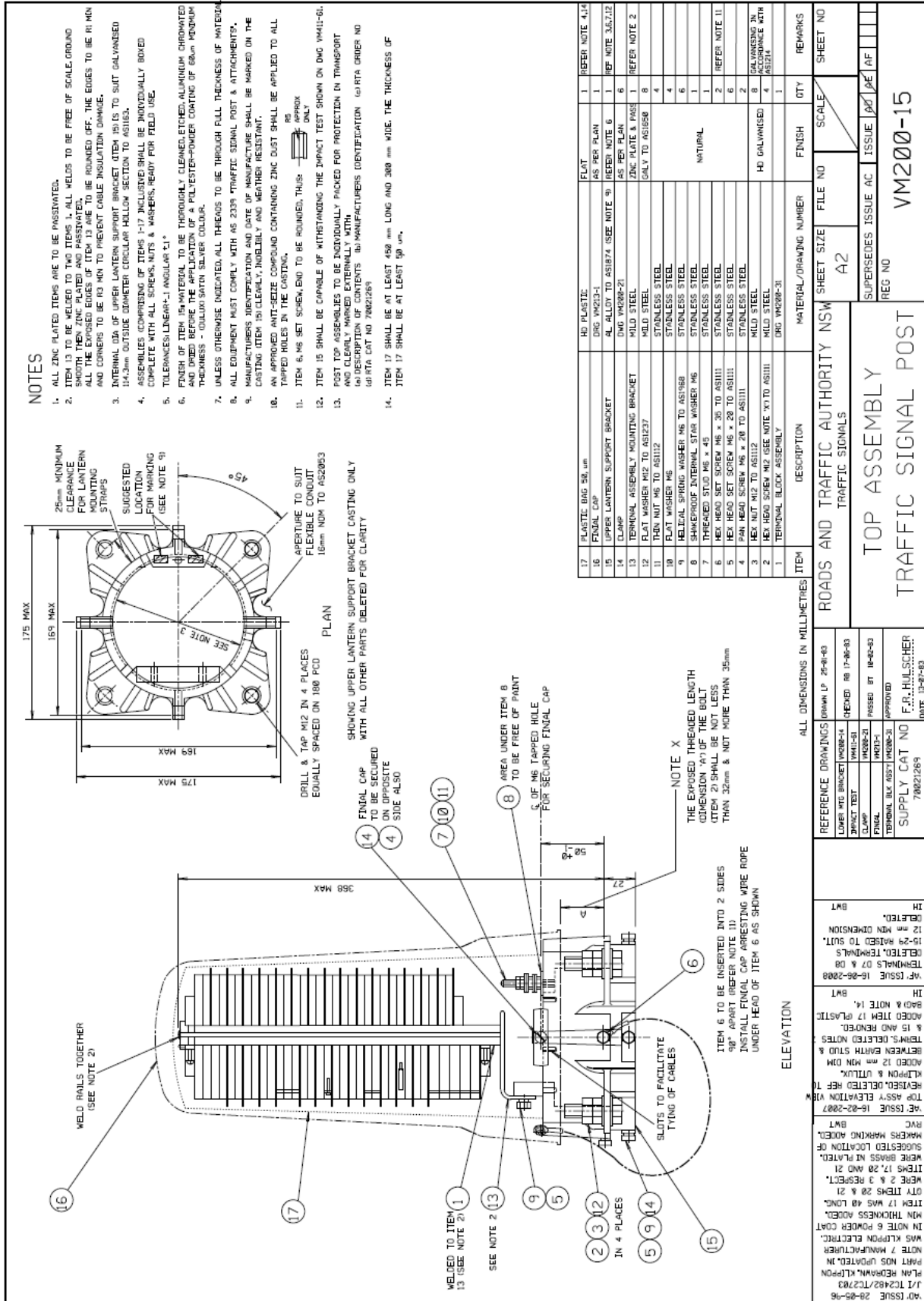
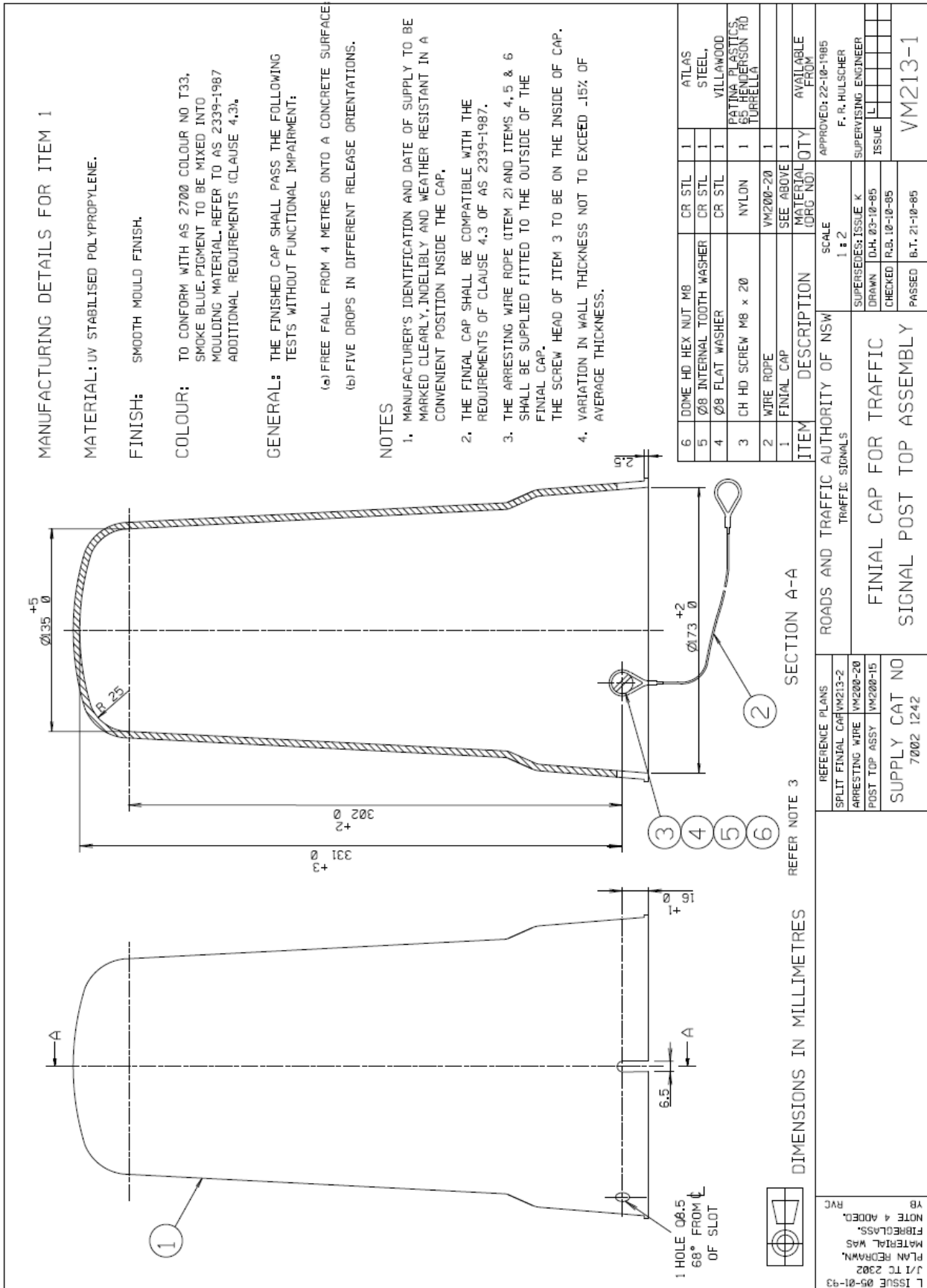



Figure B02 – Pole Top Assembly



## APPENDIX C – SIGNAL POLE DETAILS

Figure C01 – Type 1 NASSRA Pole Ground Plant

Figure C02 – Type 1 NASSRA Pole Retention Socket

Figure C03 – Type 2 Combined CCTV Pole Ground Plant

Figure C04 – Type 2 Combined CCTV Pole Retention Socket

Figure C05 – Type 8 Hinged NASSRA Pole Ground Plant

Figure C06 – Type 8 Hinged NASSRA Pole Retention Socket

Figure C07 – Type 0 Extension Signals Pole Ground Plant Ground Plant

Figure C08 – Type 11 Cycle NASSRA Pole with Cycle Hoop - Retention Socket

Figure C09 – Octagonal JUSP Pole Ground Plant

Figure C10 – Octagonal JUSP Pole Flange Mount

Figure C11 - Deleted

Figure C12 –Urban JUSP Retention Socket

Figure C13 – Type 3s & 5s JUMA - CCTV - Flange Mount

Figure C14 – Type 3, 5, & 7 JUMA Columns – Street Light Extension - Flange Mount

Figure C15 – Type 9 Cycle Mastarm Columns - Flange Mount

Figure C16 - Deleted

Figure C17 – Type 1 NASSRA Pole Cycle Hold Rail Ground Plant

Figure C18 – Pedestrian Stub Pole Cycle Hold Rail Ground Plant

Figure C01 – Type 1 NASSRA Pole Ground Plant

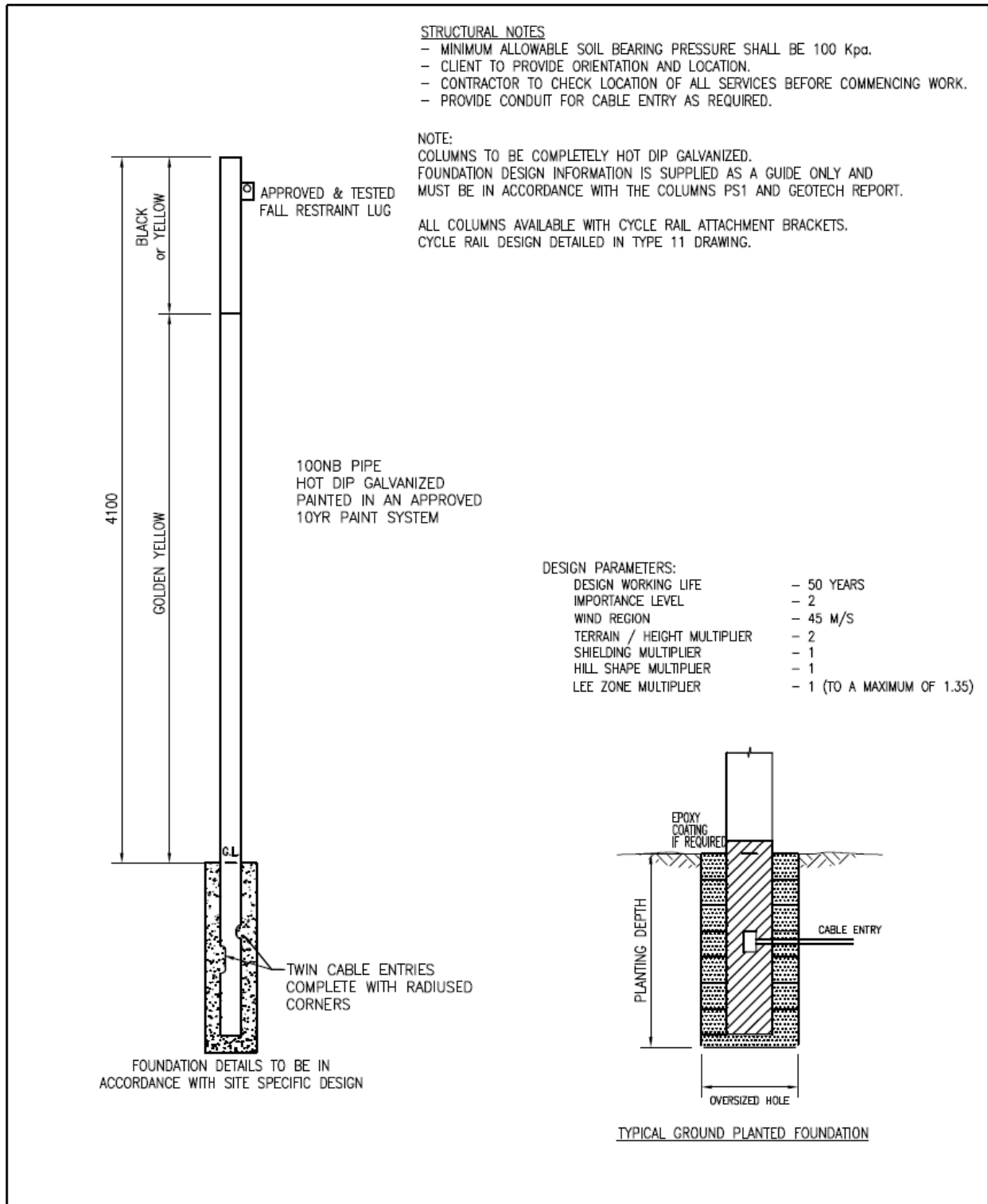

Rev	Amendment Description	By	Chk	Date	DESIGN PARAMETERS:
A	Initial issue	DE	-	08/16	Design Working Life: 50 Importance Level: 2 Wind Region: 45 Terrain Category: 2 Site Elevation:
PROJECT: NZTA P43 SPECIFICATION FOR TRAFFIC SIGNALS ADDRESS: WELLINGTON					PROJECT NUMBER -
TITLE: TYPE 1 NASSRA POLE GROUND PLANT					DRG.SIZE A4
FULL POLE DESIGN DETAILS REMAIN THE PROPERTY OF SPUNLITE POLES & CCC					SCALE AS SHOWN
					SHEET <b>C1</b>
					REVISION <b>A</b>

C:\Users\davidevans\National Pole Specification\Current Drawings\P43 National Traffic Specification Pole Drawings - 31.08.16.dwg

Figure C02 – Type 1 NASSRA Pole Retention Socket

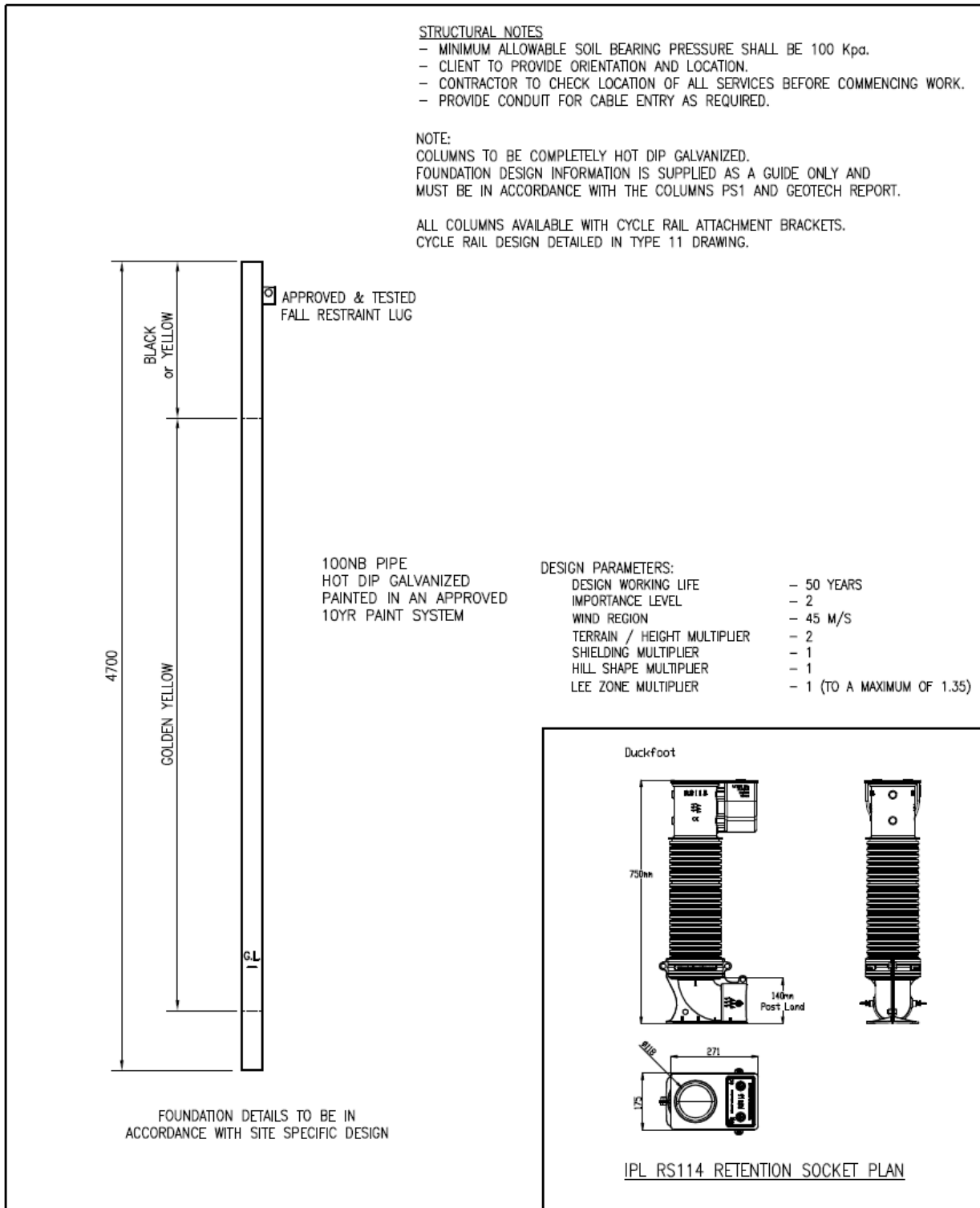

Rev	Amendment Description	By	Chk	Date	DESIGN PARAMETERS:
A	Initial issue	DE	-	08/16	Design Working Life: 50 Importance Level: 2 Wind Region: 45 Terrain Category: 2 Site Elevation:
PROJECT: NZTA P43 SPECIFICATION FOR TRAFFIC SIGNALS ADDRESS: WELLINGTON					PROJECT NUMBER
TITLE: TYPE 1 NASSRA POLE IPL RS114 RETENTION SOCKET					- SCALE
<small>FULL POLE DESIGN DETAILS REMAIN THE PROPERTY OF SPUNLITE POLES &amp; COC</small>					SHEET <b>C2</b>
<small>C:\Users\davidevans\National Pole Specification\Current Drawings\P43 National Traffic Specification Pole Drawings - 31.08.16.dwg</small>					REVISION <b>A</b>

Figure C03 – Type 2 Combined CCTV Pole Ground Plant

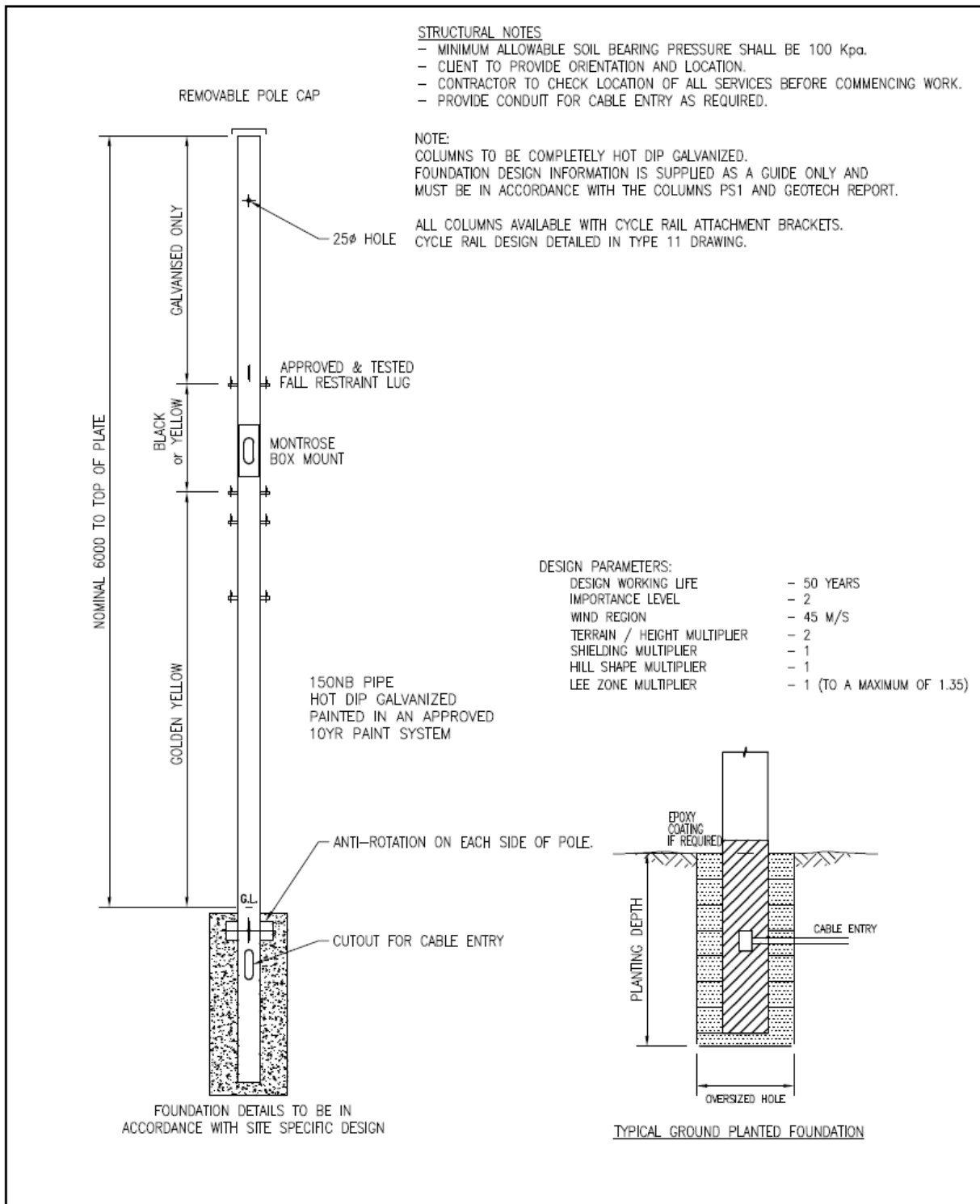

Rev	Amendment Description	By	Chk	Date	DESIGN PARAMETERS:
A	Initial issue	DE	-	08/16	Design Working Life: - Importance Level: - Wind Region: - Terrain Category: - Site Elevation: -
PROJECT: NZTA P43 SPECIFICATION FOR TRAFFIC SIGNALS ADDRESS: WELLINGTON TITLE: TYPE 2 COMBINED CCTV TRAFFIC POLE GROUND PLANT					PROJECT NUMBER: - SCALE: AS SHOWN DRG.SIZE: A4 REVISION: A

FULL POLE DESIGN DETAILS REMAIN THE PROPERTY OF SPINULITE POLES & COC  
 C:\Users\david.evans\National Pole Specification\Current Drawings\P43 National Traffic Specification Pole Drawings - 31.08.16.dwg

Figure C04 – Type 2 Combined CCTV Pole Retention Socket

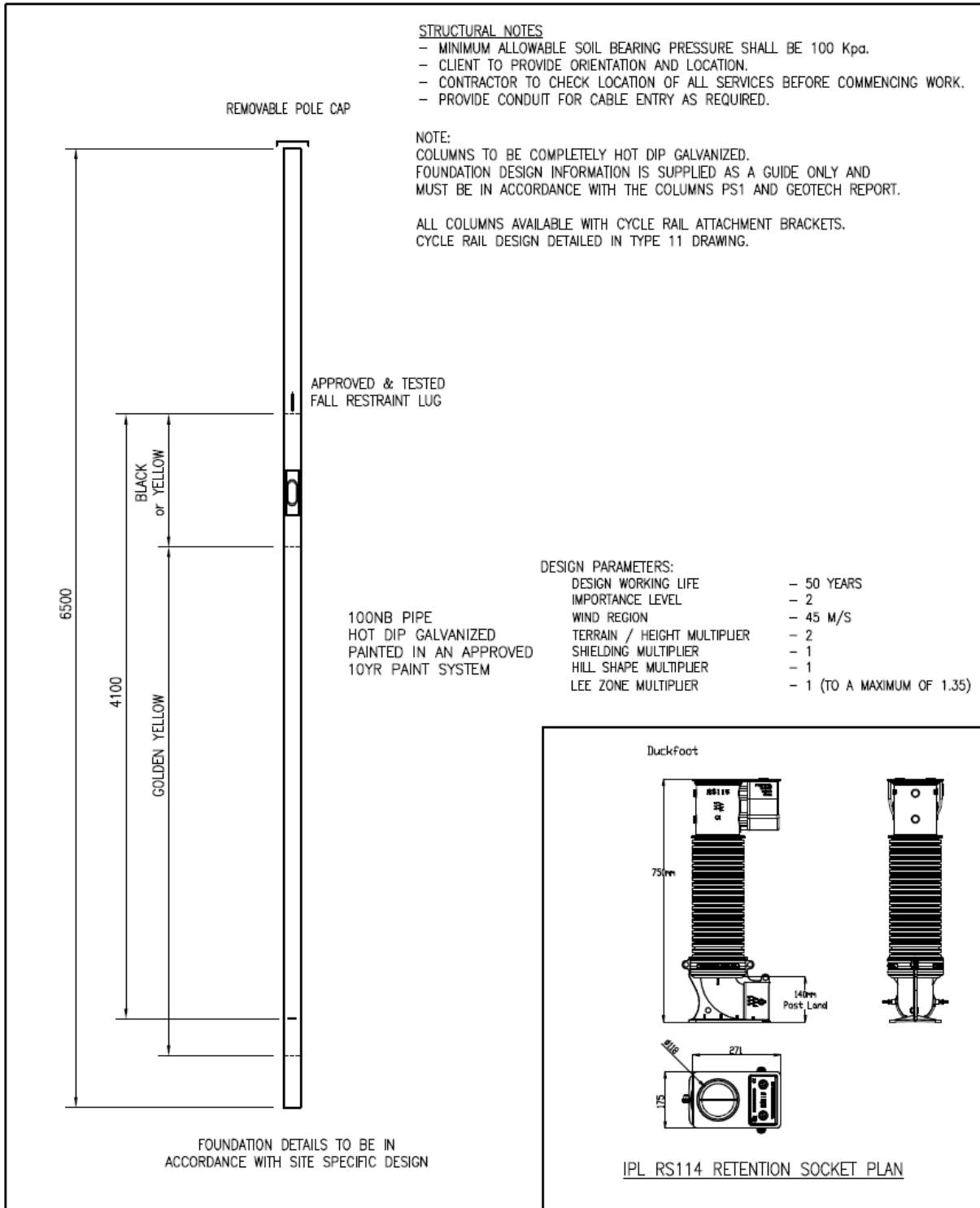

Rev	Amendment Description	By	Chk	Date	DESIGN PARAMETERS:	
A	Initial issue	DE	-	08/16	Design Working Life: 50 Importance Level: 2 Wind Region: 45 Terrain Category: 2 Site Elevation:	
PROJECT: NZTA P43 SPECIFICATION FOR TRAFFIC SIGNALS ADDRESS: WELLINGTON TITLE: TYPE 2 COMBINED CCTV SIGNAL POLE IPL RS114 RETENTION SOCKET					PROJECT NUMBER - DRG.SIZE A4 SCALE AS SHOWN	SHEET C4 REVISION A

FULL POLE DESIGN DETAILS REMAIN THE PROPERTY OF SPINLITE POLES & CO  
 C:\Users\davidevans\National Pole Specification\Current Drawings\P43 National Traffic Specification Pole Drawings - 31.08.16.dwg

Figure C05 – Type 8 Hinged NASSRA Pole Ground Plant

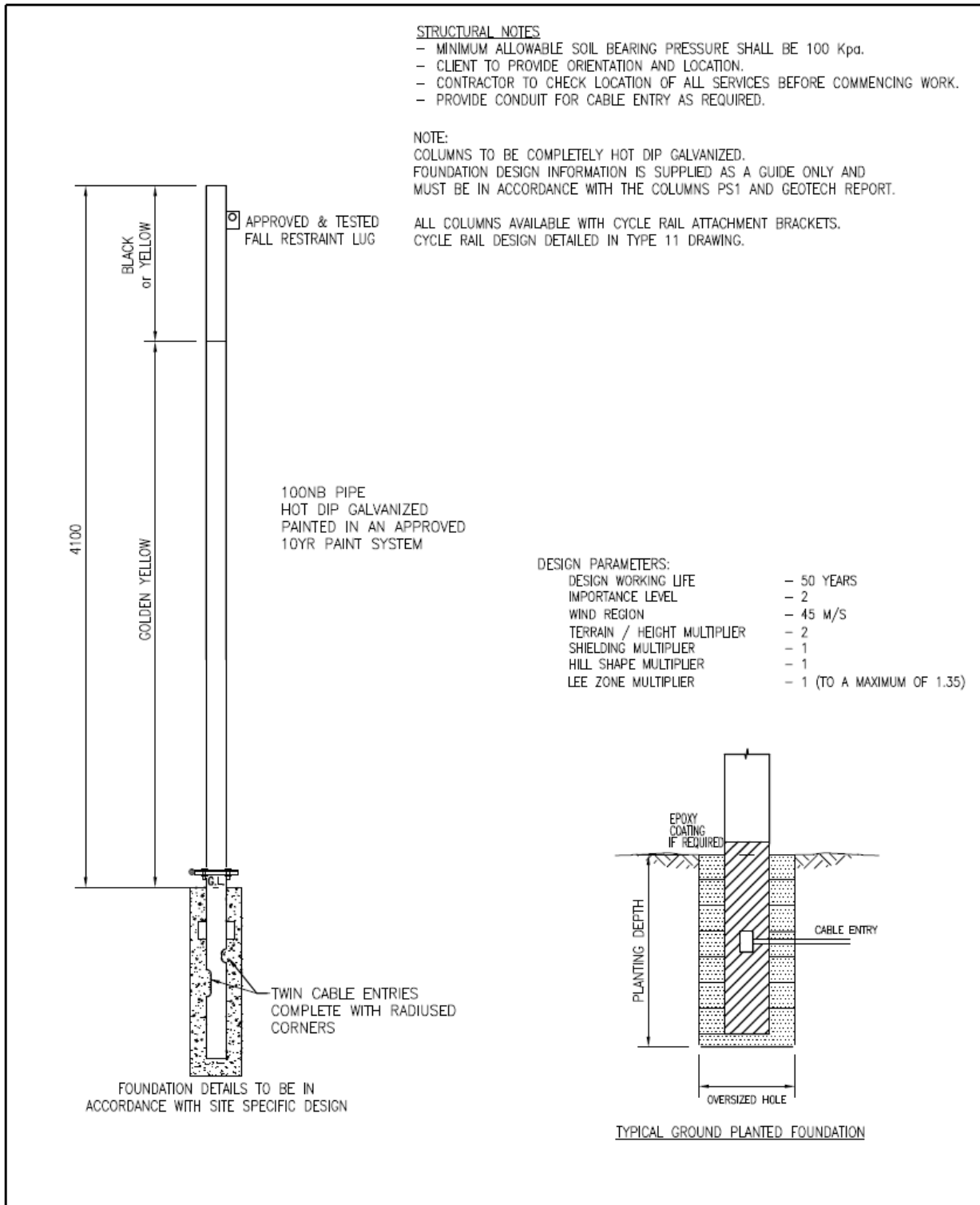

Rev	Amendment Description	By	Chk	Date	DESIGN PARAMETERS:	
A	Initial issue	DE	-	08/16	Design Working Life: - Importance Level: - Wind Region: - Terrain Category: - Site Elevation: -	
PROJECT: NZTA P43 SPECIFICATION FOR TRAFFIC SIGNALS ADDRESS: WELLINGTON					PROJECT NUMBER	SHEET
TITLE: TYPE 8 HINGED NASSRA POLE GROUND PLANT					-	<b>C5</b>
FULL POLE DESIGN DETAILS REMAIN THE PROPERTY OF SPINUTE POLES & COC					DRG.SIZE	REVISION
C:\Users\daivevans\National Pole Specification\Current Drawings\P43 National Traffic Specification Pole Drawings - 31.08.16.dwg					A4	<b>A</b>
					SCALE	
					AS SHOWN	

Figure C06 – Type 8 Hinged NASSRA Pole Retention Socket

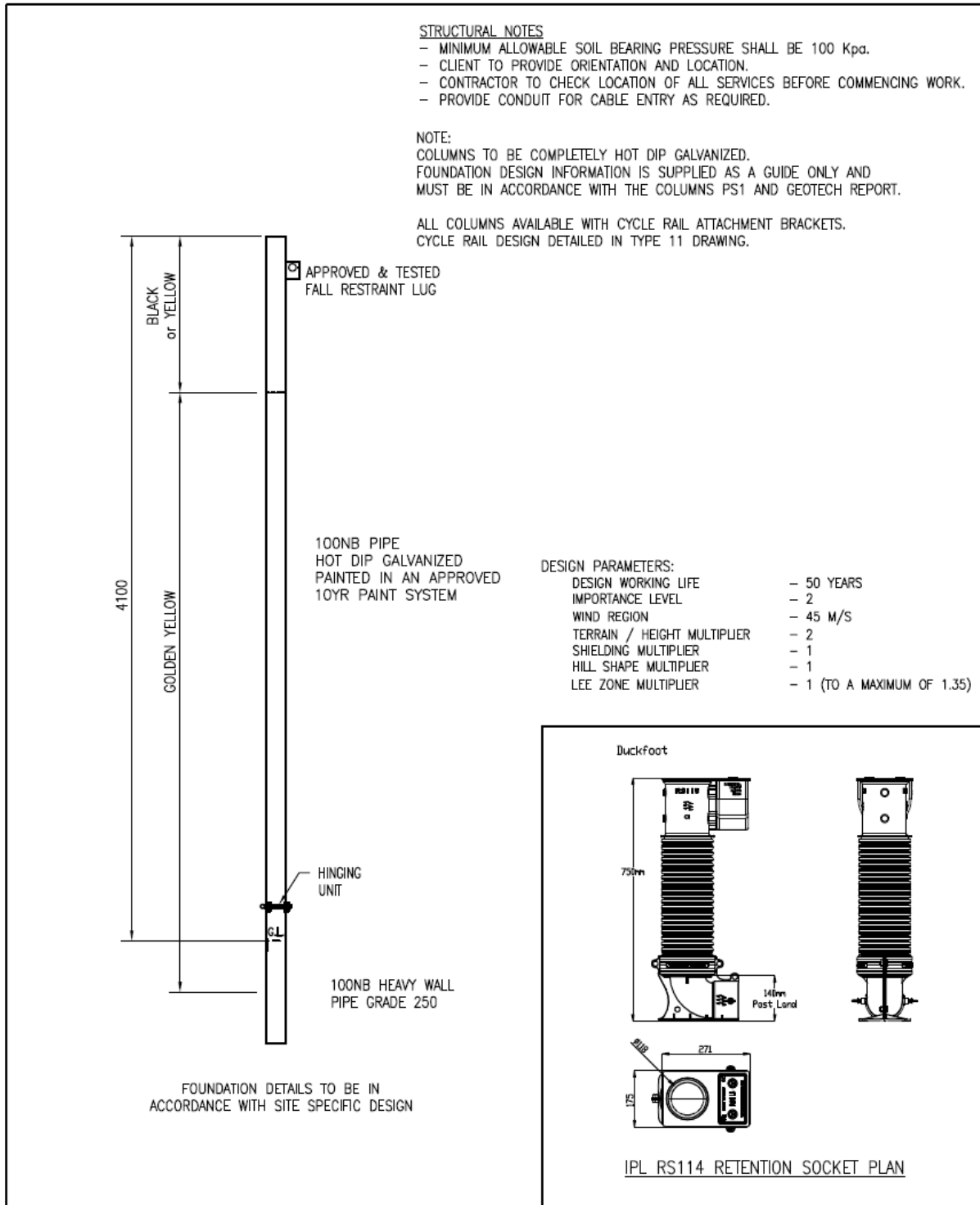

Rev	Amendment Description	By	Chk	Date	DESIGN PARAMETERS:	
A	Initial issue	DE	-	08/16	Design Working Life: - Importance Level: - Wind Region: - Terrain Category: - Site Elevation: -	
PROJECT: NZTA P43 SPECIFICATION FOR TRAFFIC SIGNALS ADDRESS: WELLINGTON					PROJECT NUMBER	SHEET
TITLE: TYPE 8 HINGED NASSRA POLE IPL RS114 RETENTION SOCKET					DRG.SIZE	SCALE
FULL POLE DESIGN DETAILS REMAIN THE PROPERTY OF SPUNLITE POLES & CCC C:\Users\davidvans\National Pole Specification\Current Drawings\P43 National Traffic Specification Pole Drawings - 31.08.16.dwg					A4	AS SHOWN
						C6
						REVISION
						A



Figure C07 – Type 0 Extension Signals Pole Ground Plant Ground Plant

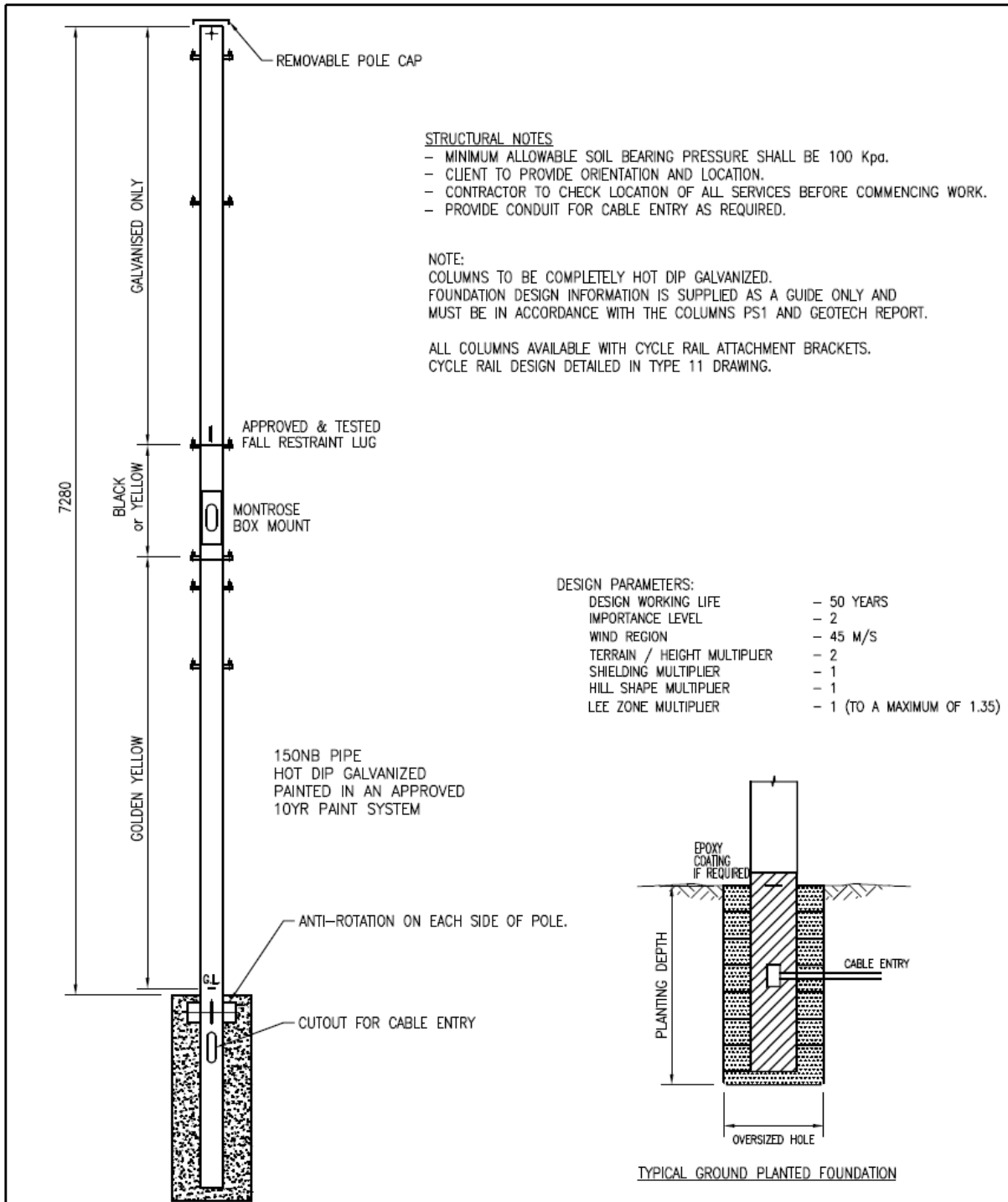

FOUNDATION DETAILS TO BE IN ACCORDANCE WITH SITE SPECIFIC DESIGN

Rev	Amendment Description	By	Chk	Date	DESIGN PARAMETERS:	
A	Initial issue	DE	-	08/16	Design Working Life: - Importance Level: - Wind Region: - Terrain Category: - Site Elevation: -	
PROJECT: NZTA P43 SPECIFICATION FOR TRAFFIC SIGNALS ADDRESS: WELLINGTON					PROJECT NUMBER	SHEET
TITLE: TYPE 0 EXTENSION SIGNALS POLE GROUND PLANT					DRG.SIZE	REVISION
<small>FULL POLE DESIGN DETAILS REMAIN THE PROPERTY OF SPUNLITE POLES &amp; CO</small>					A4	A

C:\Users\davidevans\National Pole Specification\Current Drawings\P43 National Traffic Specification Pole Drawings - 31.08.16.dwg

Figure C08 – Type 11 Cycle NASSRA Pole with Cycle Hoop - Retention Socket

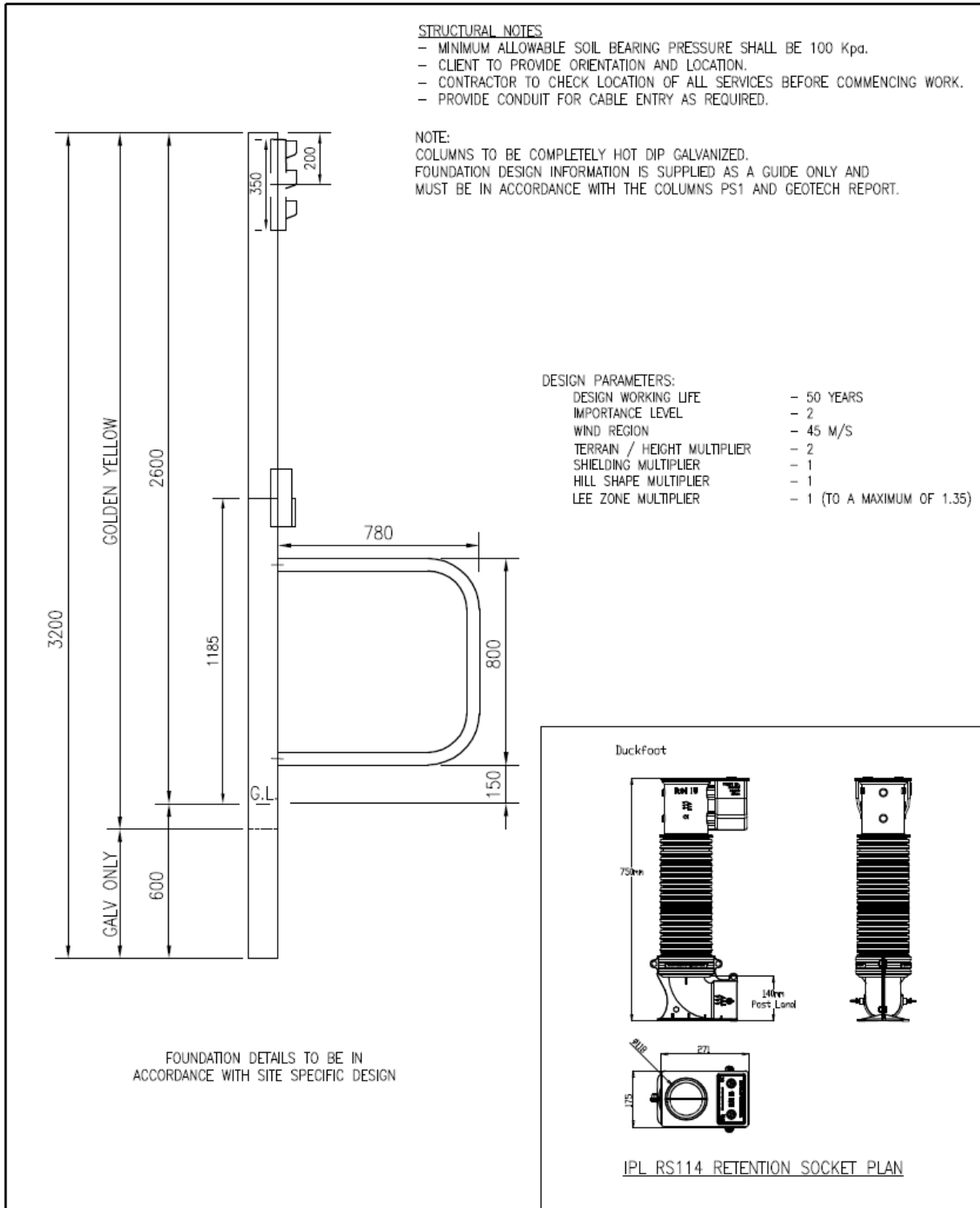

Rev	Amendment Description	By	Chk	Date	DESIGN PARAMETERS:	
A	Initial issue	DE	-	09/16	Design Working Life: - Importance Level: - Wind Region: - Terrain Category: - Site Elevation: -	
PROJECT: NZTA P43 SPECIFICATION FOR TRAFFIC SIGNALS ADDRESS: WELLINGTON					PROJECT NUMBER	SHEET
TITLE: TYPE 11 CYCLE NASSRA POLE with CYCLE HOOP IPL RS114 RETENTION SOCKET					DRG.SIZE	SCALE
FULL POLE DESIGN DETAILS REMAIN THE PROPERTY OF SPINRITE POLES & CO. CC					A4	AS SHOWN
						REVISION
						A

C:\Users\davidevans\National Pole Specification\Current Drawings\P43 National Traffic Specification Pole Drawings - 31.08.16.dwg

Figure C09 – Octagonal JUSP Pole Ground Plant

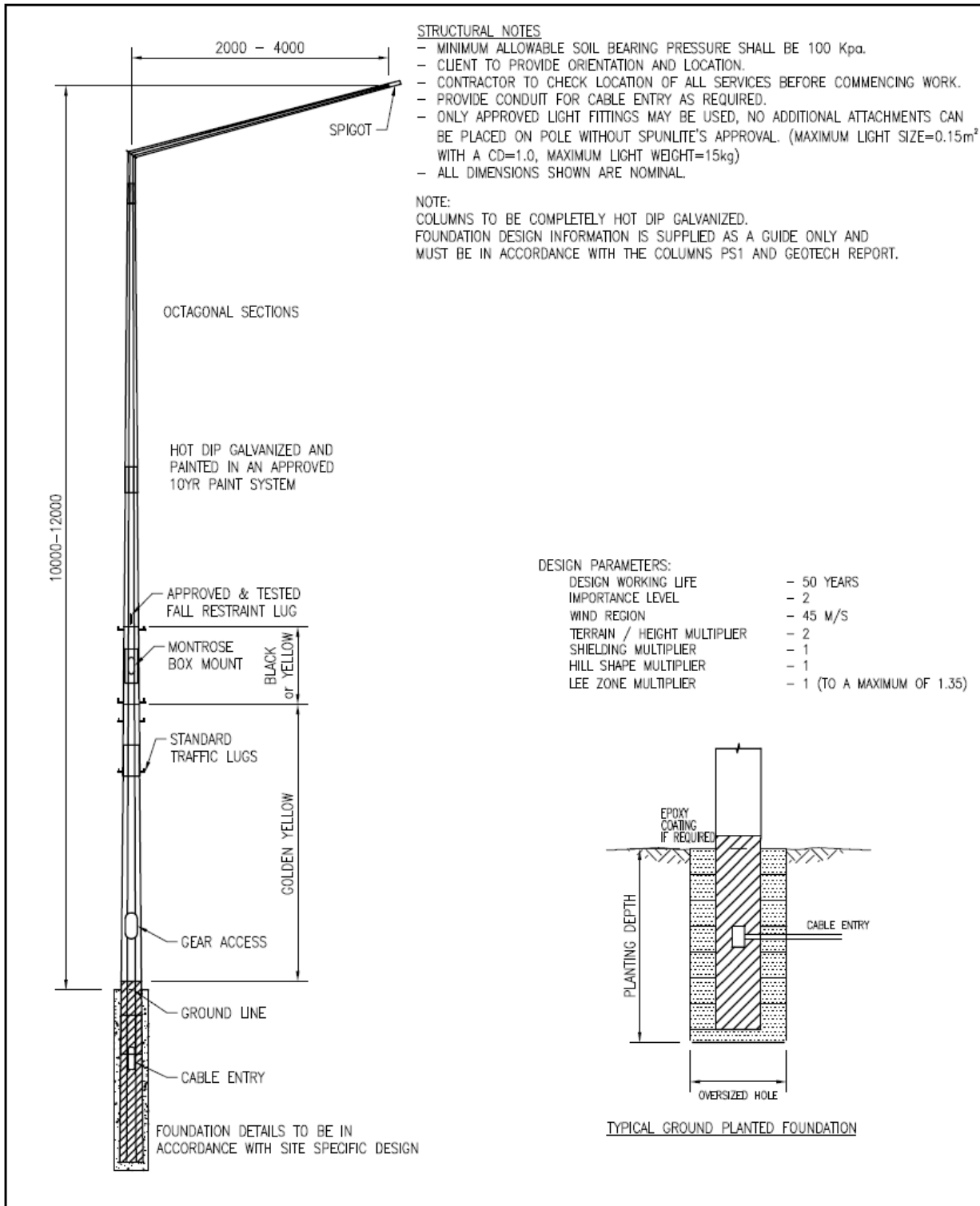

Rev	Amendment Description	By	Chk	Date	DESIGN PARAMETERS:
A	Initial issue	DE	-	09/16	Design Working Life: - Importance Level: - Wind Region: - Terrain Category: - Site Elevation: -

PROJECT: NZTA P43 SPECIFICATION FOR TRAFFIC SIGNALS		PROJECT NUMBER	SHEET
ADDRESS: WELLINGTON		-	C9
TITLE: OCTAGONAL JOINT USE SIGNAL POLE (JUSP) GROUND PLANT		DRG.SIZE	SCALE
FULL POLE DESIGN DETAILS REMAIN THE PROPERTY OF SPUNLITE POLES & COC		A4	AS SHOWN
C:\Users\davidevans\National Pole Specification\Current Drawings\P43 National Traffic Specification Pole Drawings - 31.08.16.dwg			REVISION
			A

Figure C10 – Octagonal JUSP Pole Flange Mount

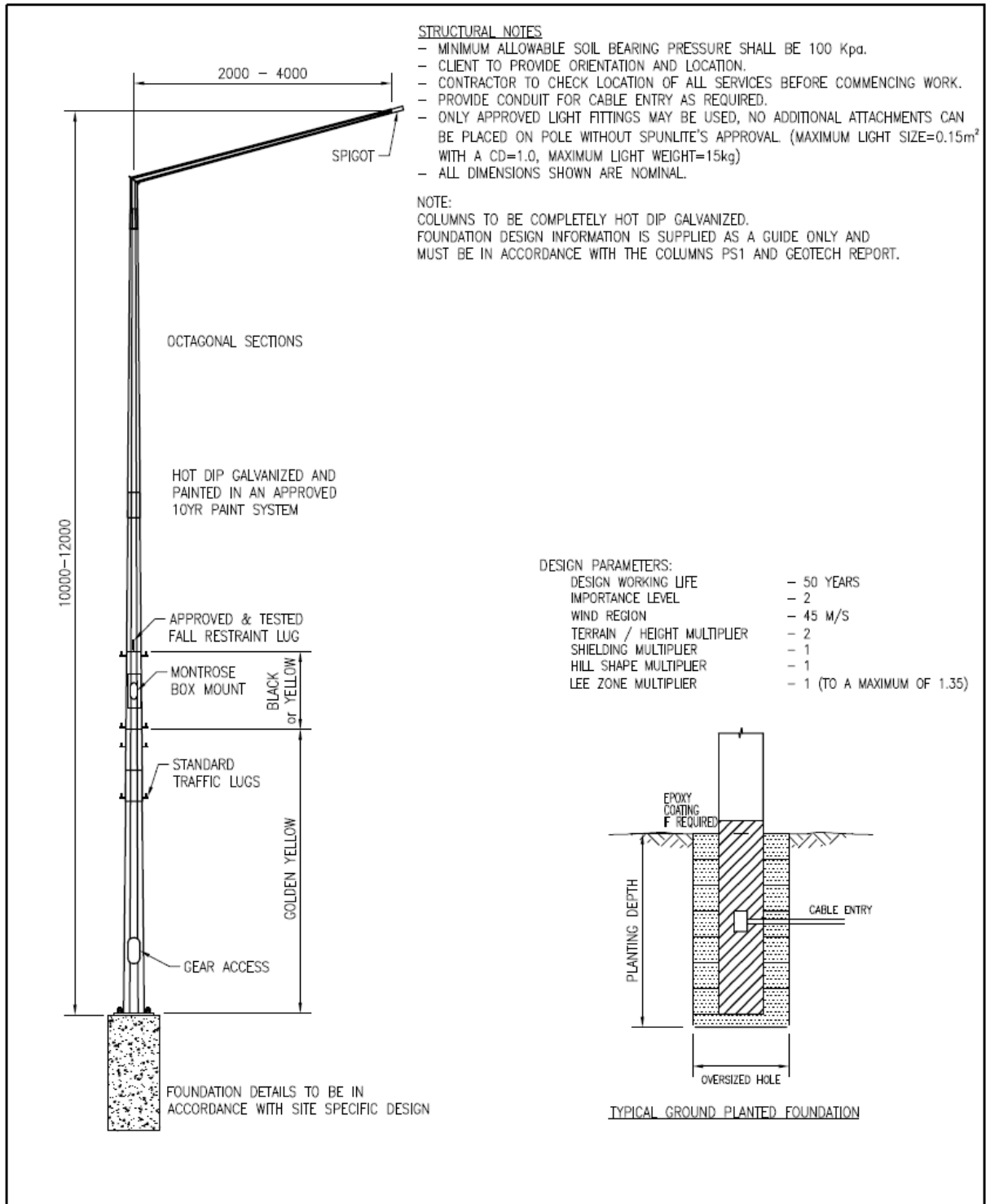

Rev	Amendment Description	By	Chk	Date	DESIGN PARAMETERS:
A	Initial issue	DE	-	09/16	Design Working Life: - Importance Level: - Wind Region: - Terrain Category: - Site Elevation: -

PROJECT: NZTA P43 SPECIFICATION FOR TRAFFIC SIGNALS		PROJECT NUMBER		SHEET <b>C10</b>
ADDRESS: WELLINGTON		-		
TITLE: OCTAGONAL JOINT USE SIGNAL POLE (JUSP) – FLANGE MOUNT		DRG.SIZE	SCALE	REVISION
		A4	AS SHOWN	<b>A</b>

FULL POLE DESIGN DETAILS REMAIN THE PROPERTY OF SPUNLITE POLES & CO.  
C:\Users\davidevans\National Pole Specification\Current Drawings\P43 National Traffic Specification Pole Drawings - 31.08.16.dwg

Figure C12 –Urban JUSP Retention Socket

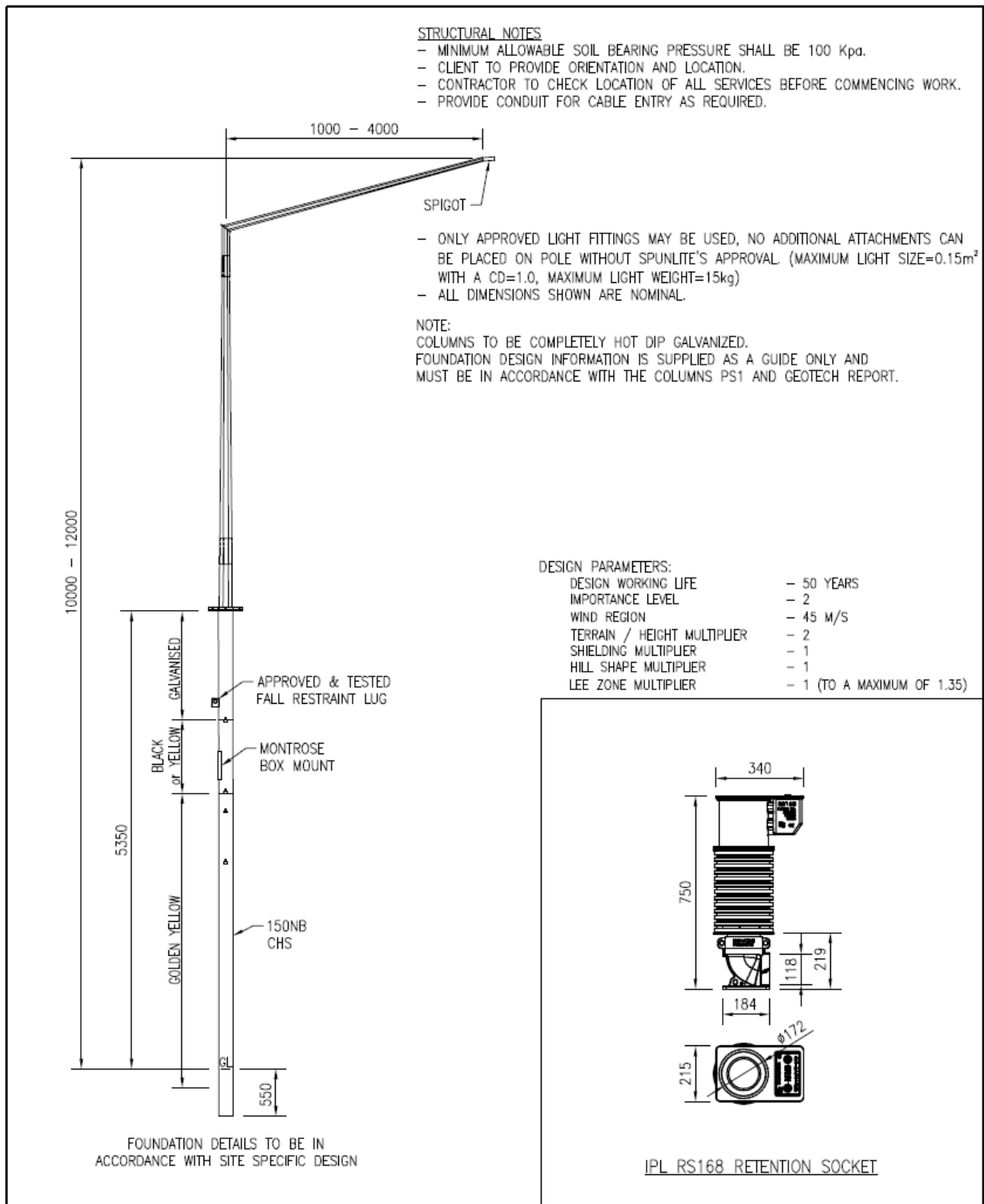

Rev	Amendment Description	By	Chk	Date	DESIGN PARAMETERS:
A	Initial issue	DE	-	07/15	Design Working Life: - Importance Level: - Wind Region: - Terrain Category: - Site Elevation: -
PROJECT: NZTA P43 SPECIFICATION FOR TRAFFIC SIGNALS ADDRESS: WELLINGTON					PROJECT NUMBER
TITLE: URBAN - JOINT USE SIGNAL POLE (JUSP) IPL RS168 RETENTION SOCKET					DRG.SIZE
FULL POLE DESIGN DETAILS REMAIN THE PROPERTY OF SPUNLITE POLES & COC C:\Users\davidevans\National Pole Specification\Current Drawings\P43 National Traffic Specification Pole Drawings - 31.08.16.dwg					SCALE
					SHEET
					REVISION
					<b>C12</b>
					<b>A</b>

Figure C13 – Type 3s & 5s JUMA - CCTV - Flange Mount

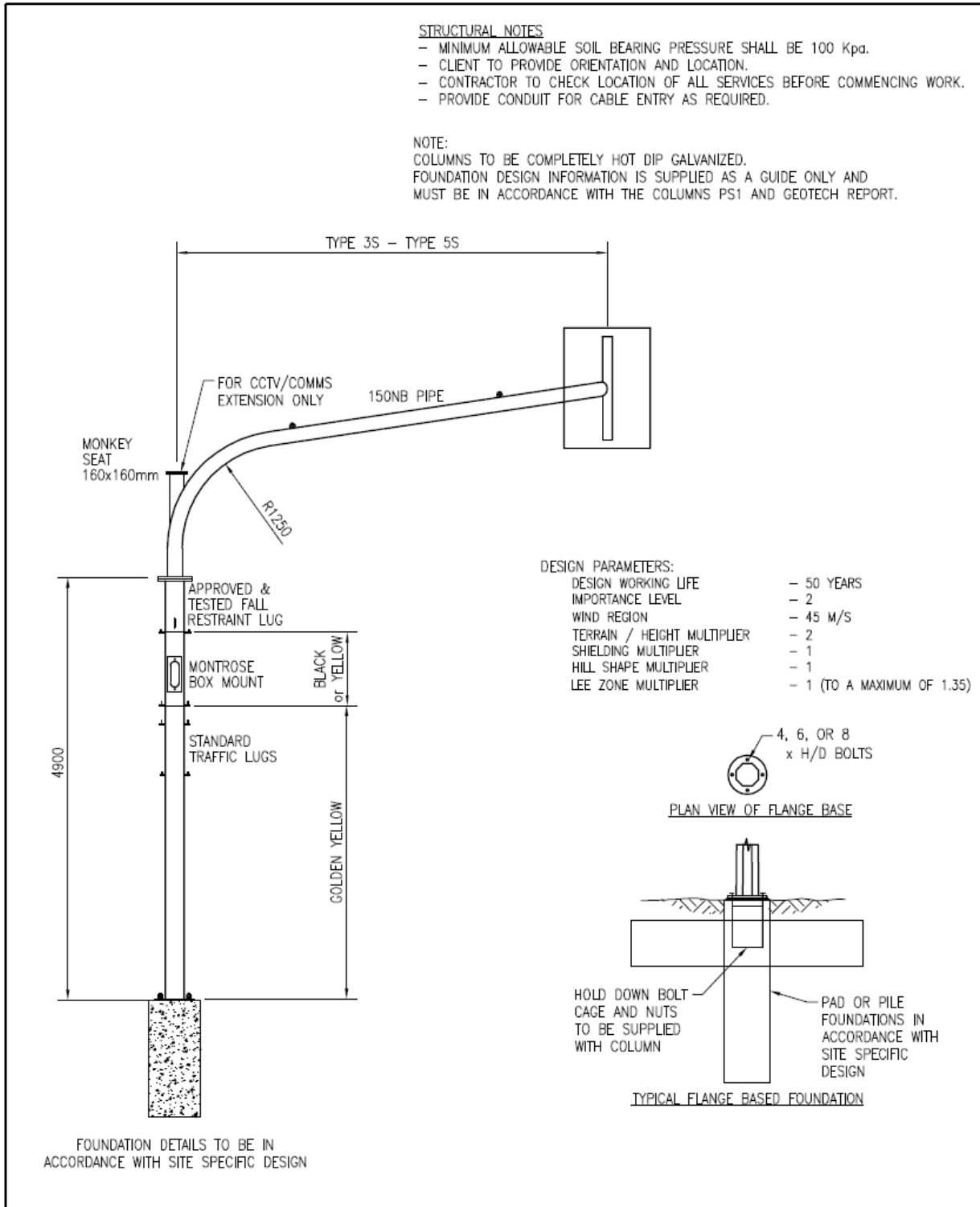

Rev	Amendment Description	By	Chk	Date	DESIGN PARAMETERS:
A	Initial issue	DE	-	07/15	Design Working Life: - Importance Level: - Wind Region: - Terrain Category: - Site Elevation: -
					PROJECT NUMBER
PROJECT: NZTA P43 SPECIFICATION FOR TRAFFIC SIGNALS					-
ADDRESS: WELLINGTON					<b>C13</b>
TITLE: TYPE 3s & 5s JOINT USE MAST ARM - CCTV FLANGE MOUNT					DRG.SIZE
					SCALE
					REVISION
					<b>A</b>

FULL POLE DESIGN DETAILS REMAIN THE PROPERTY OF SPINUTE POLES & CO.  
C:\Users\davidevans\National Pole Specification\Current Drawings\P43 National Traffic Specification Pole Drawings - 31.08.16.dwg

Figure C14 – Type 3, 5, & 7 JUMA Columns – Street Light Extension - Flange Mount

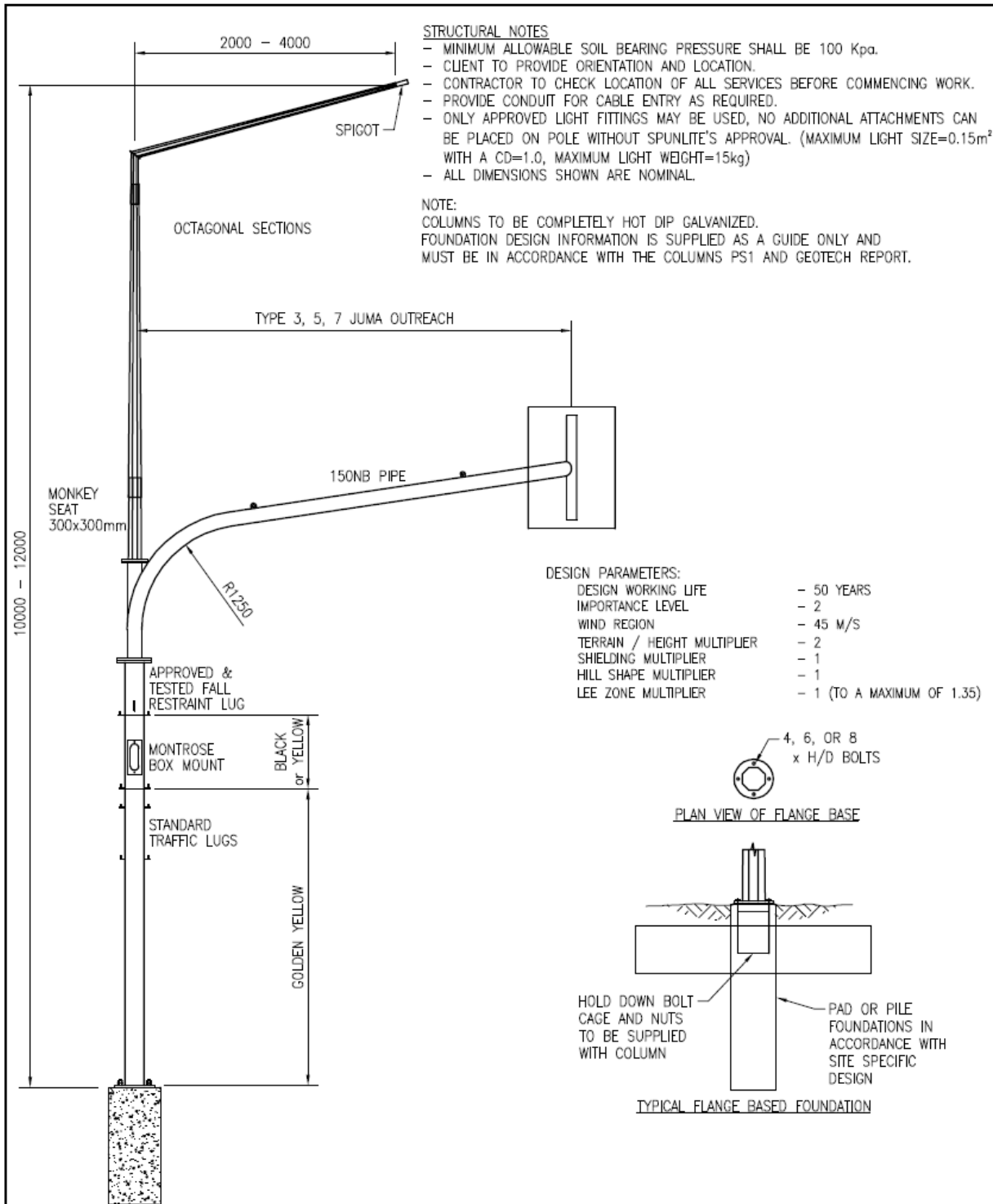

Rev	Amendment Description	By	Chk	Date	DESIGN PARAMETERS:	
A	Initial issue	DE	-	07/15	Design Working Life: - Importance Level: - Wind Region: - Terrain Category: - Site Elevation: -	
PROJECT: NZTA P43 SPECIFICATION FOR TRAFFIC SIGNALS ADDRESS: WELLINGTON					PROJECT NUMBER	SHEET
TITLE: TYPE 3, 5 & 7 JOINT USE MAST ARM (JUMA) FLANGE MOUNT with STREET LIGHTING EXTENSION					DRG.SIZE	SCALE
FULL POLE DESIGN DETAILS REMAIN THE PROPERTY OF SPUNLITE POLES & COE					A4	AS SHOWN
						REVISION
						A

C:\Users\daivevans\National Pole Specification\Current Drawings\P43 National Traffic Specification Pole Drawings - 31.08.16.dwg

Figure C15 – Type 9 Cycle Mastarm Columns - Flange Mount

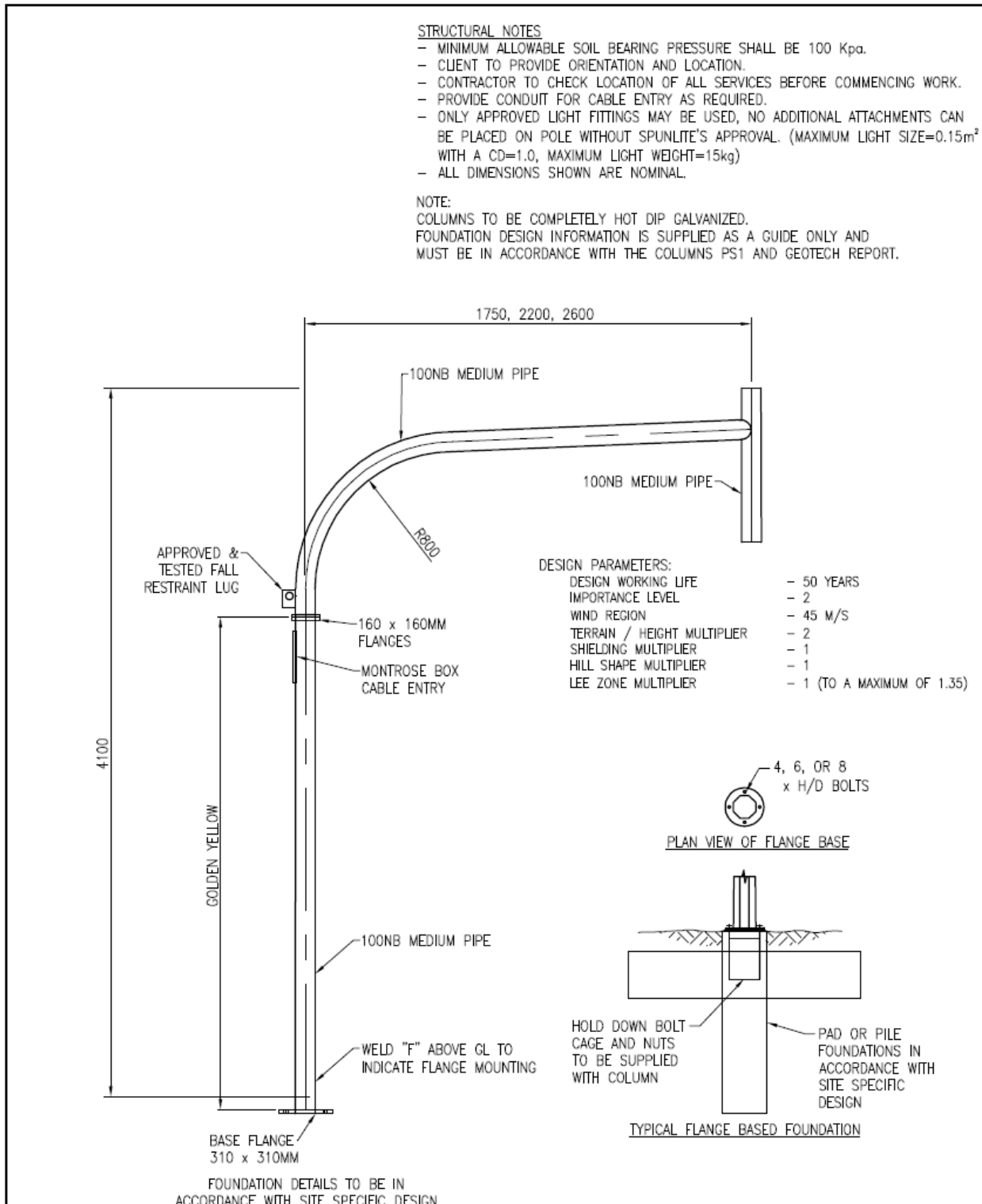

Rev	Amendment Description	By	Chk	Date	DESIGN PARAMETERS:
A	Initial issue	DE	-	07/15	Design Working Life: - Importance Level: - Wind Region: - Terrain Category: - Site Elevation: -
PROJECT: NZTA P43 SPECIFICATION FOR TRAFFIC SIGNALS ADDRESS: WELLINGTON TITLE: TYPE 9 CYCLE MAST ARM COLUMN FLANGE MOUNT					PROJECT NUMBER: - SCALE: AS SHOWN REVISION: A

FULL POLE DESIGN DETAILS REMAIN THE PROPERTY OF SPUNLITE POLES & CO  
 C:\Users\davidevans\National Pole Specification\Current Drawings\P43 National Traffic Specification Pole Drawings - 31.08.16.dwg



Figure C17 – Type 1 NASSRA Pole Cycle Hold Rail Ground Plant

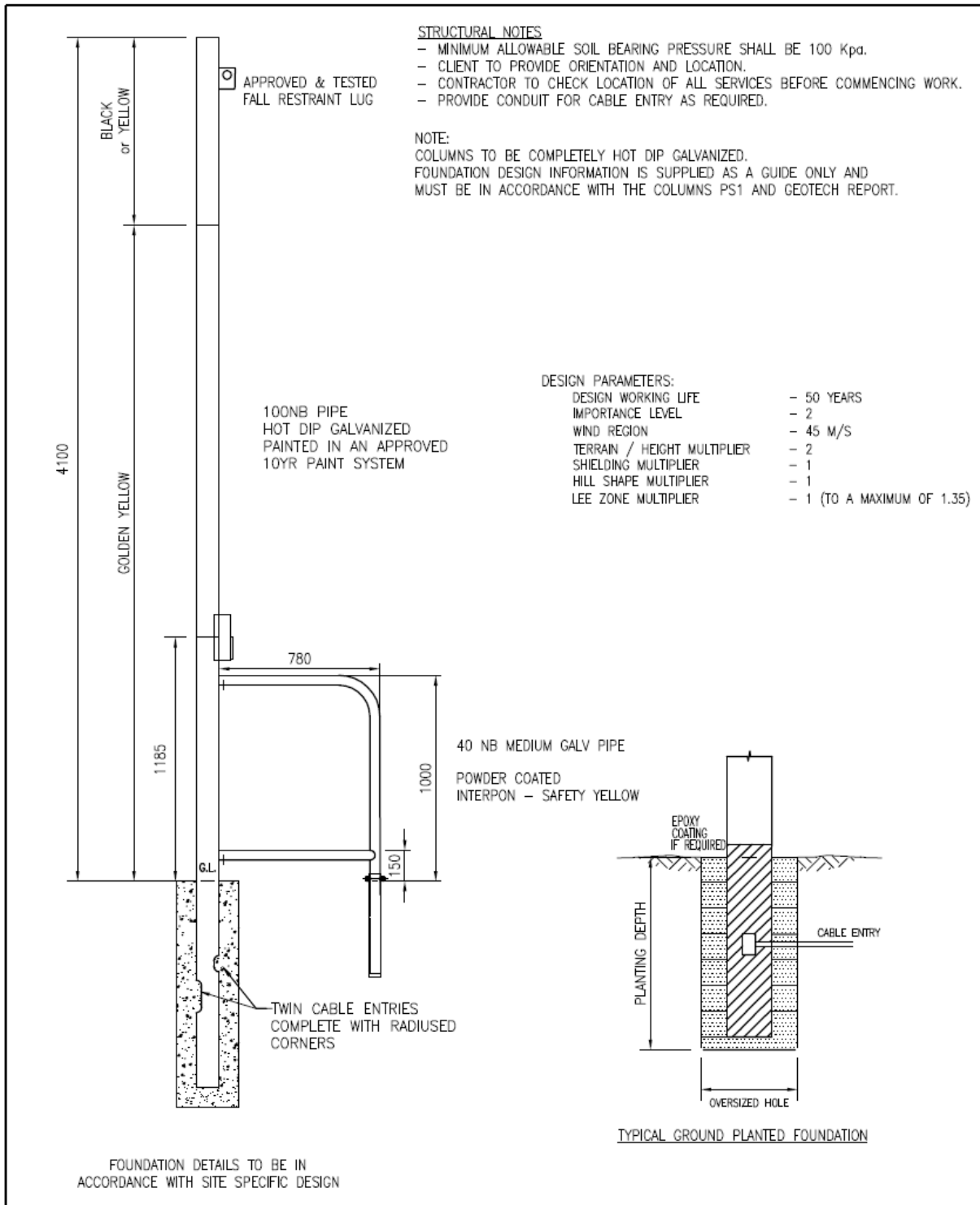

Rev	Amendment Description	By	Chk	Date	DESIGN PARAMETERS:
A	Initial issue	DE	-	09/16	Design Working Life: - Importance Level: - Wind Region: - Terrain Category: - Site Elevation: -
PROJECT: NZTA P43 SPECIFICATION FOR TRAFFIC SIGNALS ADDRESS: WELLINGTON					PROJECT NUMBER -
TITLE: TYPE 1 NASSRA POLE with CYCLE HOLDING RAIL GROUND PLANT					DRG.SIZE A4
FULL POLE DESIGN DETAILS REMAIN THE PROPERTY OF SPINUTE POLES & COE					SCALE AS SHOWN
					SHEET <b>C18</b> REVISION <b>A</b>

C:\Users\davidevans\National Pole Specification\Current Drawings\P43 National Traffic Specification Pole Drawings - 31.08.16.dwg

Figure C18 – Pedestrian Stub Pole Cycle Hold Rail Ground Plant

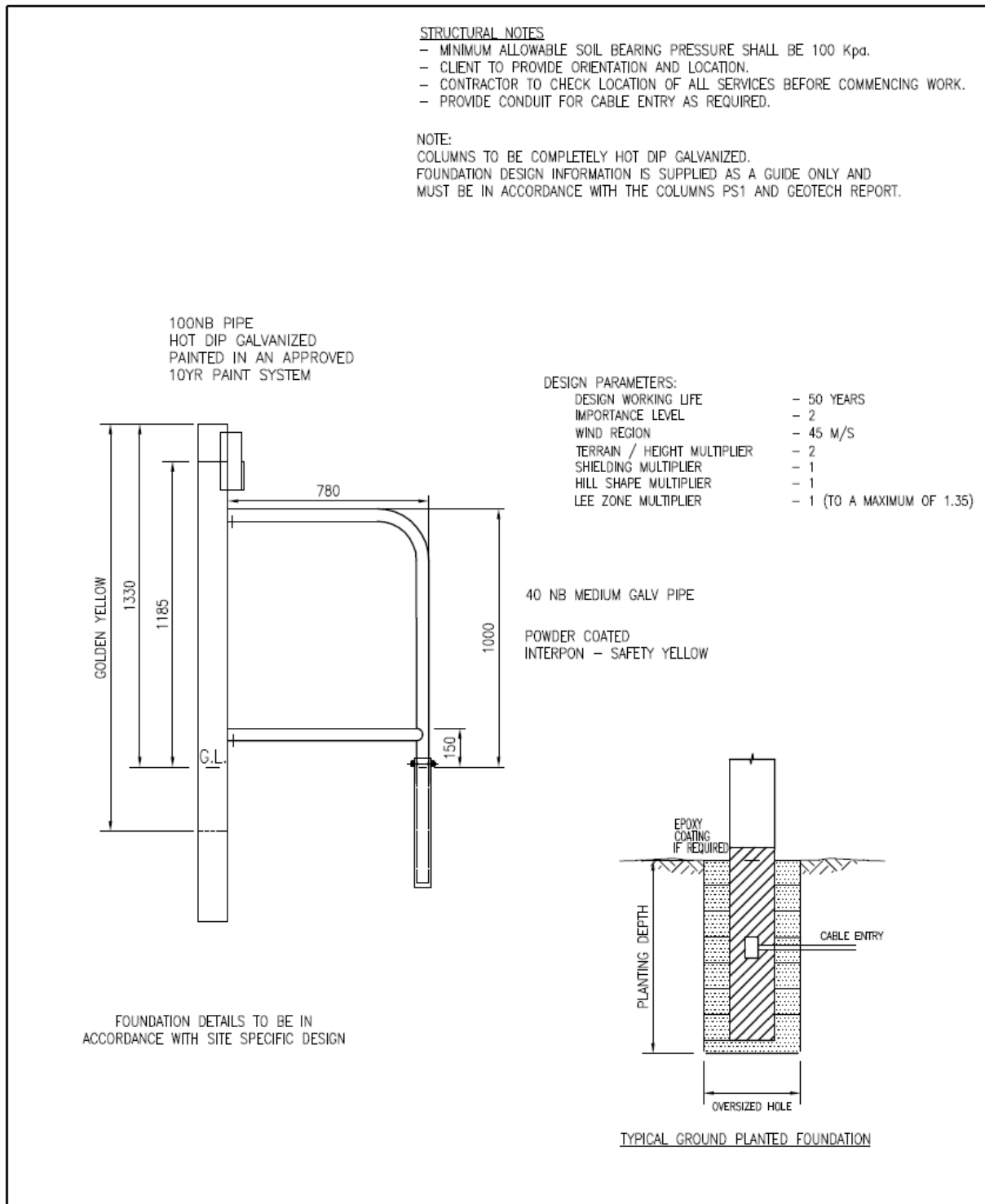

Rev	Amendment Description	By	Chk	Date	DESIGN PARAMETERS:	
A	Initial issue	DE	-	09/16	Design Working Life: - Importance Level: - Wind Region: - Terrain Category: - Site Elevation: -	
PROJECT: NZTA P43 SPECIFICATION FOR TRAFFIC SIGNALS ADDRESS: WELLINGTON					PROJECT NUMBER	SHEET
TITLE: PEDESTRIAN STUB POLE with HOLDING RAIL GROUND PLANT					-	<b>C18</b>
FULL POLE DESIGN DETAILS REMAIN THE PROPERTY OF SPURITE POLES & COC					DRG.SIZE	REVISION
C:\Users\davidevans\National Pole Specification\Current Drawings\P43 National Traffic Specification Pole Drawings - 31.08.16.dwg					A4	<b>A</b>
					SCALE	
					AS SHOWN	

# APPENDIX D – POLE DUCT ACCESS DETAILS

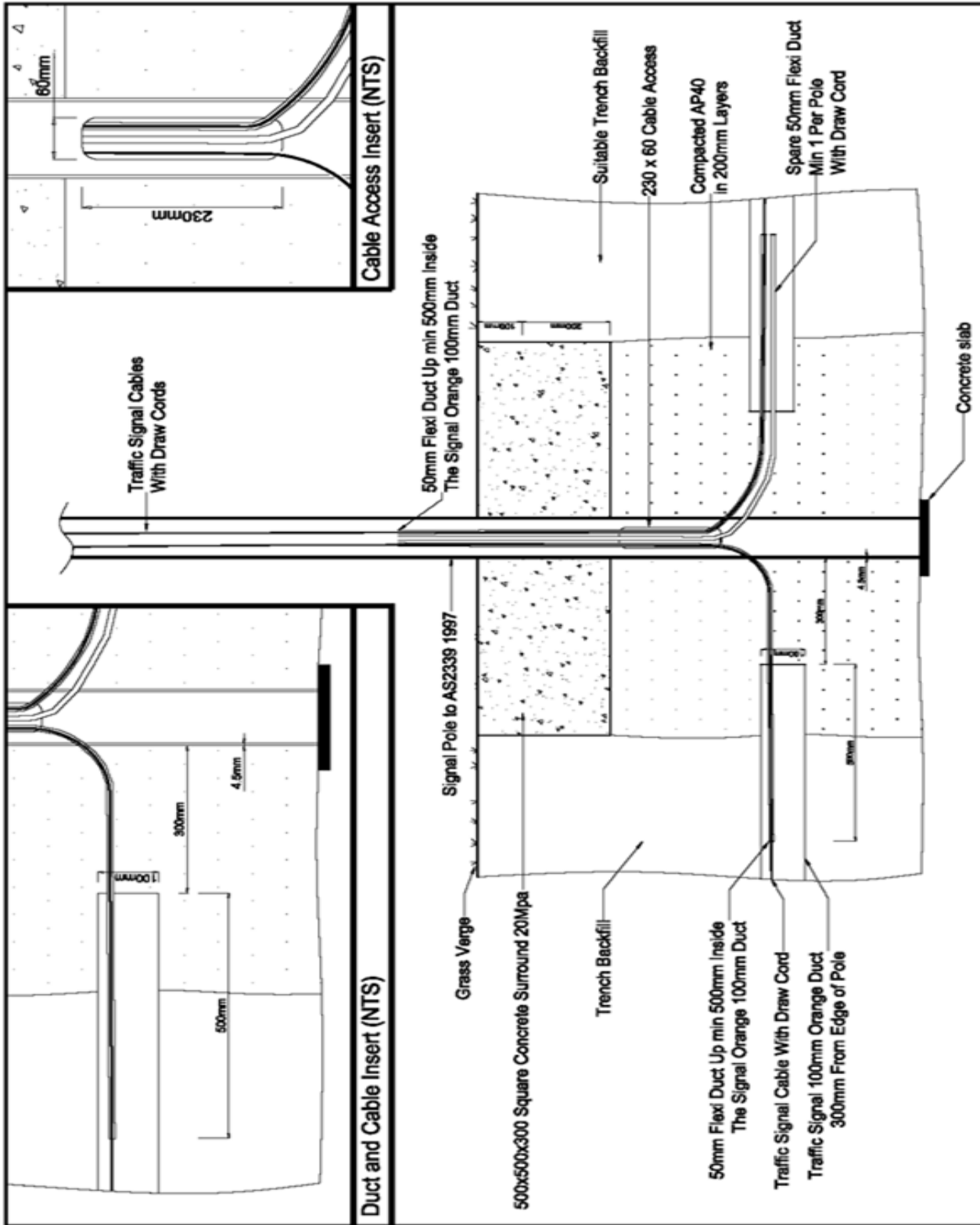

Figure D01 - Duct access details

# APPENDIX E - LANTERN SHROUD DETAILS - INFORMATIVE

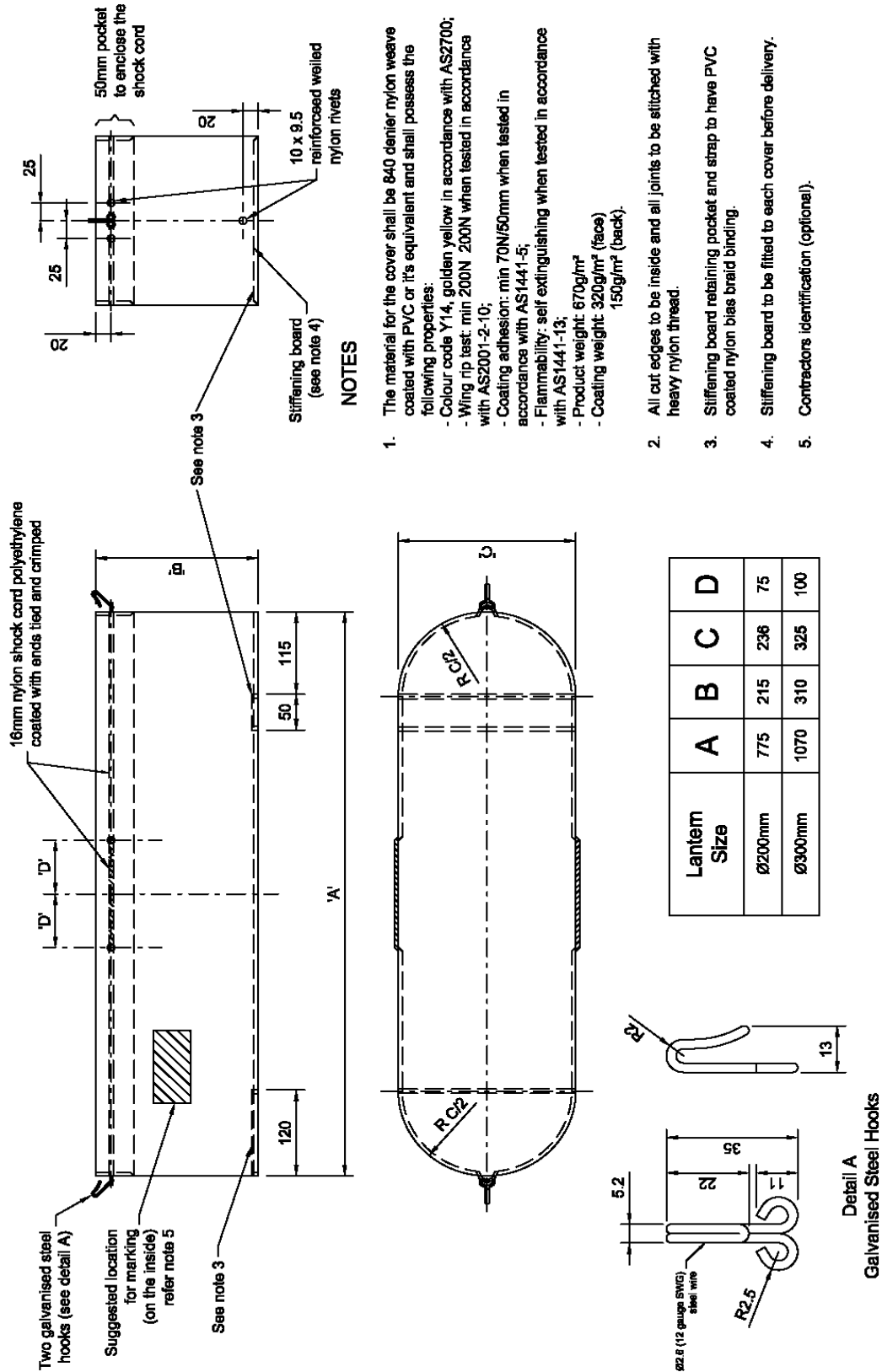

Figure E01 - Vehicle lantern shroud

# APPENDIX F – CABLE TERMINATION CHART EXAMPLE

C.C.C TRAFFIC SIGNAL CABLE CONNECTION CHART

INTERSECTION NO: 3 5 5  
 LOCATION: GRAHAMS/MEMORIAL  
 LAST UPDATED: OCT 2001

NOTE : TERMINAL NO. = CORE NO. UNLESS SHOWN OTHERWISE  
 ONLY ACTIVE CONNECTIONS & CHANGES IN CORE NO. SHOWN

	CABINET			POLE 1		POLE 2		POLE 3		POLE 4		POLE 5		POLE 6		POLE 7		POLE 8		POLE 9		POLE 10		POLE 11		POLE 12								
	T	To Pole No.:		T	To Pole:	T	To Pole:	T	To Pole:	T	To Pole:	T	To Pole:	T	To Pole:	T	To Pole:	T	To Pole:	T	To Pole:	T	To Pole:	T	To Pole:	T	To Pole:							
Pole Number -	E	2	11	10	E		E		E		E		E		E		E		E		E		E		E		E							
Number of cores -	R	25	25	25	R		R		R		R		R		R		R		R		R		R		R		R							
Cable Direction -						C	3		2	4		3		6		5	7		6	8		7	9		8	10		C	9		C	1		
OUTPUT GROUP 1	A RED	1		1				1		1				1		1																		
OUTPUT GROUP 2	A YEL	2						2		2				2		2																		
OUTPUT GROUP 3	A GRN	3						3		3				3		3																		
OUTPUT GROUP 4		8	8	8		8		8						8		8																		
OUTPUT GROUP 5		9	9	9		9		9						9		9																		
OUTPUT GROUP 6		10	10	10		10		10						10		10																		
OUTPUT GROUP 7		11		11						11			11								11			11										
OUTPUT GROUP 8		12		12						12			12								12			12										
OUTPUT GROUP 9		13		13						13			13								13			13										
OUTPUT GROUP 10		14	14	14						14			14								14			14										
OUTPUT GROUP 11		15	15	15						15			15								15			15										
OUTPUT GROUP 12		16	16	16						16			16								16			16										
OUTPUT GROUP 13		19		17																	17			17										
OUTPUT GROUP 14		20		18																	18			18										
OUTPUT GROUP 15		21		19																	19			19										
OUTPUT GROUP 16		22		20																	20			20										
OUTPUT GROUP 17		21		21						21			21																					
OUTPUT GROUP 18		22		22						22			22																					
OUTPUT GROUP 19		17	17			17				17																								
OUTPUT GROUP 20		18	18			18				18																								
PB1 (9)	13		23	23																	23			23										
PB2 (10)	14			24																														
PB3 (11)	15	25		25						25		25			24						24			23										
PB4 (12)	16	23	25			23				23																								
DET NO																																		
DET NO																																		
DET NO																																		
DET NO																																		
EARTH (4)		4	4			4	4			4	4			4	4						4	4			4	4								
DET. RETURN (5)		5	5			5	5			5	5			5	5						5	5			5	5								
PHASE (6)																																		
NEUTRAL (7)		7	7			7	7			7	7			7	7						7	7			7	7								

Table F01 – Example cable termination chart

# APPENDIX G – SITE ACCEPTANCE TEST CHART

<b>Intersection name:</b>		
<b>Number:</b>	<b>Date:</b>	
<b>Contract name and number</b>		
<b>Commencement date</b>		
<b>Signals and civil contractor</b>		
<b>Pre-inspections</b>	<b>Y/N or N/A</b>	<b>Comments</b>
Duct connections to poles		
Loops positioned correctly		
Recorded loop positions		
Texiphalte installed cleanly		
> 12 mm loop feeder cover		
<b>Operations</b>	<b>Y/N or N/A</b>	<b>Comments</b>
E-Prom labelled (check sum)		
Lamps off, controller ops		
Copy RAM to controller		
Check fault log, clear		
<b>Full start up:</b>		
Flash test each Signal Group		
Flashing ambers working		
Check all red (SPT = 10 s)		
Revision on correct phases		
All default phases call		
Monitor operations in HHT		
<b>After full start up:</b>		
Other phases call (xsf/flags)		
Ped protection OK		
Mains off-on, controller ops OK?		
Last gasp (PF in SCATS Log)		
<b>Poles</b>	<b>Y/N or N/A</b>	<b>Comments</b>
Correct location & vertical		
Concrete collar (500 mm)		
Painted		
Fold down poles work		
Pole numbers installed & manufactures date fitted		
<b>All lanterns</b>	<b>Y/N or N/A</b>	<b>Comments</b>
Attached and aligned correctly		
Locking device, spring washers, and lock nuts fitted		
Correct height (3.2 m – 4.1 m)		
Directional arrows aligned		
Louvres installed correctly		
Correct visors installed		
<b>Ped lanterns:</b>		
Attached correctly		
Ped lantern height/align (3 m)		
Correct visors installed		

**Table G01 – Site acceptance sheet 1 of 3**

<b>Intersection name:</b>	
<b>Number:</b>	<b>Date:</b>

<b>Pedestrian crossing</b>	<b>Y/N or N/A</b>	<b>Comments</b>
<b><i>Push buttons:</i></b>		
Install correct height (1.1 m)		
Callbox Operating (calling walk)		
Sound levels (High)		
Audio unit audible (operating)		
Mutable unit OK (if fitted)		
Arrow aligned to crossing		
Tactile vibration OK		
PB light indicator (if fitted)		
<b><i>Ped Detectors:</i></b>		
Camera installed OK		
Camera activates OK		
Instruction labels installed		
<b>Controller</b>	<b>Y/N or N/A</b>	<b>Comments</b>
Make, type, and size		
Signal group size/No. of		
Detector card size/No. of		
DP number		
ICP number		
Det card operation check		
Gland plate labels (on top)		
Cable looms labels (under)		
Detector switches labelled		
Signal groups numbered		
Detector blocks numbered		
Cable glands sealed		
Spare sockets working		
Wiring tidy		
Logic rack secure		
Door seals and locks		
<b>Vehicle detectors</b>	<b>Y/N or N/A</b>	<b>Comments</b>
KJB 100 mm concrete surround		
KJB 20 mm concrete pad		
Loop joins using approved method		
> 1.8 m slack in controller base		
> 0.5 m slack in KJB		
<b>Cabling and earthing</b>	<b>Y/N or N/A</b>	<b>Comments</b>
Telecom cable identified		
Impedence test reports		
Street lighting labelled		
RCDs labelled		

**Table G01 – Site acceptance sheet 2 of 3 (continued)**

<b>Intersection name:</b>	
<b>Number:</b>	<b>Date:</b>

<b>Cabling and earthing</b>	<b>Y/N or N/A</b>	<b>Comments</b>
Draw cables installed/work		
Controller cabinet earthed		
In cable slack in chambers		
<b>Civil Works</b>	<b>Y/N or N/A</b>	<b>Comments</b>
Connect ducting as per specs		
Chambers level with surface		
Plastered inside chamber		
Kerbing installed correctly		
KJB concrete installed (100 mm)		
KJB drainage installed (100 mm)		
Road surface condition		
Footpath surface condition		
Pram ramps installed		
Directional Pavers Aligned		
Road markings installed		
Drainage. ESP at crossings		
Grass berms restored		
Correct signage installed		
Temp advance warnings		
<b>Documentation</b>	<b>Y/N or N/A</b>	<b>Comments</b>
<i>In controller</i> (Laminated)		
Controller information sheet		
Intersection information sheet		
Intersection as-built drawing		
Electrical Certificate of Compliance (incl Earth Loop Impedance Values for each pole)		
Log book		
<b>Other</b>	<b>Y/N or N/A</b>	<b>Comments</b>

<b>Commissioning/Switch-on date:</b>		
<b>RCA Traffic Signal Engineer:</b>		
<b>Sign:</b>		<b>Date:</b>
<b>Signal contractor:</b>		
<b>Sign:</b>		<b>Date:</b>
<b>HAND OVER TO RCA FOR OPERATIONS AUTHORISED WHEN SIGNED ABOVE</b>		

Table G01 – Site acceptance sheet 3 of 3 (continued)



## APPENDIX H – CONTROLLER BENCH TESTING FORM

<b>Intersection name</b>	
<b>Intersection identification</b>	<b>Controlling authority:</b>
	<b>Intersection number:</b>
<b>Personality file number</b>	
<b>Date Software / SFT created</b>	
<b>Name of PROM tester</b>	
<b>Date Software / SFT bench tested</b>	
<b>Software / SFT bench test</b>	<div style="display: flex; justify-content: space-around;"> <span>Pass</span> <span>Fail</span> </div>

<b>Test</b>	<b>Result/ comment</b>	<b>Signed</b>
<b>Time settings - Vehicle</b>		
<b>Time settings - Pedestrian</b>		
<b>Time settings - Presence</b>		
<b>Time settings - Special purpose</b>		
<b>Flexilink call data</b>		
<b>Filter operation</b>		
<b>Special logic</b>		
<b>Pedestrian Protection</b>		
<b>Calling detectors</b>		
<b>Phase movements</b>		
<b>Conflict matrix</b>		
<b>Ram version / Checksum No.</b>		
<b>Functionality</b>		

**Table H01 – Controller bench test form**

# APPENDIX I – STREET-LIGHT CIRCUIT EXAMPLE

Figure I01 - Typical circuitry for street-lighting powered from a traffic signal controller.

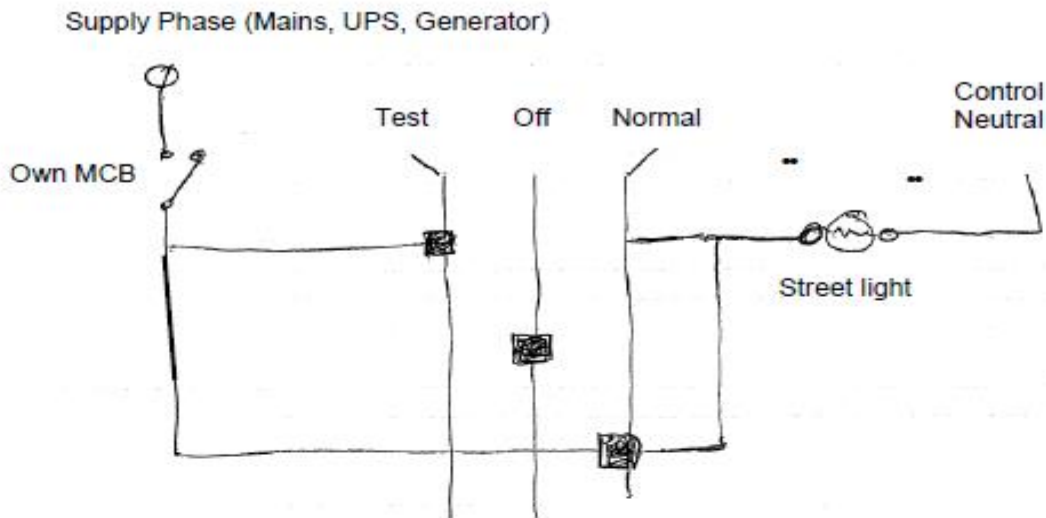

**Kraus & Naimer**  
BLUE LINE switchgear

		CA10	A240				
<b>Face Plate</b>							
		1	3	5	7	9	11
Switching Angle	60	2	4	6	8	10	12
Total switching Angle	120		C				
	0 OFF						
	270						
	285						
	300						
	315						
	1 NORM	■					
	330						
	345						
	0						
	15						
	2 TEST		■				
	30						
	45						
	60						
	75						

# APPENDIX J – NEW INTERSECTION COMMISSIONING FORM

Table J01 – New installation acceptance (NIA) checklist follows on next page

Description	Evidence	Check
Traffic signal controller	RTA type approval – Module	
	RTA type approval – Housing	
LED aluminium lanterns	RTA type approval for each lantern type	
	NATA certified laboratory report	
Poles under 5.2 m	Comply with AS 2339	
	SUMB to be an RTA approved UMB	
Poles over 5.2 m	Engineers design and certificate of compliance	
Poles (posts)	Design certificate and a certificate of compliance from a suitable Chartered Professional Engineer (CPEng)	
RAMM collection sheet	Completed RAMM Asset Data Form (Appendix K)	
Test certificates	Original certificate of compliance	
	Bench testing laboratory statement/certificate with the test engineers signature	
	Comply with the Electricity (Safety) Regulations, AS/NZS 3000, and approved by the local power supply authority	
	Delivery dockets of concrete supply from a certified readymix plant	
Supply of electric power	The original of the certificate of compliance	
Producer statements/Hardware guarantees	Certified copy of products/equipment on a signed and dated paper with company letterhead, as well as a copy of the drawing for the products/equipment being certified	
Documentation	Instruction manual	
	Both two hardcopies and an electronic copy of controller information sheet and cable termination chart	
	Cabling and ducting record	
Reflector	Comply with AS 2144	
Visors and louvre	Comply with AS 2144	
Pedestrian push button assemblies	Comply with AS 2353	
	Approved push button units	
	Approved audio tactile driver and housing	
Vehicle loop detectors	Comply with AS 2703	
Detector loop wire	Comply with AS/NZS 2276.3	
Earthing/bonding	Comply with AS/NZS 3000:2018	
Switch/Earth termination	Comply with IEC 60947-7-1, IEC 60998-1, and IEC 60998-2-1	
As-built drawings	Supplied as hardcopy and in AutoCAD.DWG formats	
C & I	Hard copy and spreadsheet formats	
Keys	Two full sets	

### APPENDIX K – RAMM ASSET DATA FORM

Int #		Date:				Int Name													
Item	Pole No.	Pole Mount (G.p., Flange, etc.)	Road the pole is on			Condition ratings	Lantern												
			No. of aspects	Road name - Material (plastic or metal)	Size		Level (OH or LL)	Type (Pri, Sec, Tert, Ped)	Manufa cturer	Lantern body (metal or plastic)	Display (Thru, LT, RT, Ped, T&RT, T&LT, L&RT)	No. of aspects	Lens size	Lamp type (QH, LED)					

Table K01 - Asset information form

# APPENDIX L - CONTROLLER GLAND PLATE - INFORMATIVE

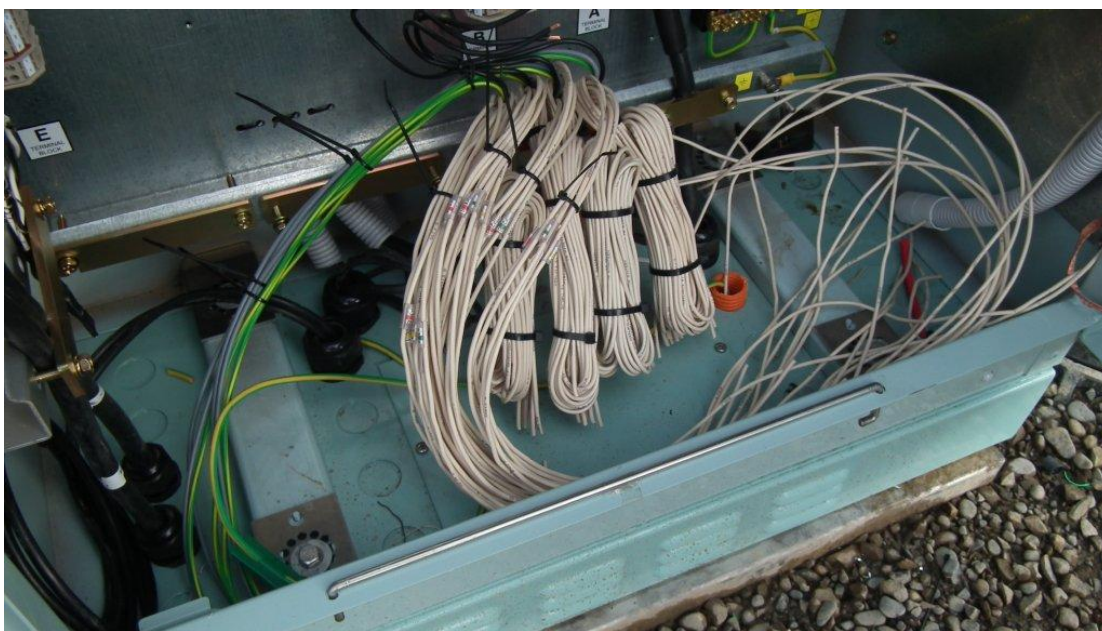

**Figure L01 -Bottom of controller with gland plate fitted and access panel fitted**

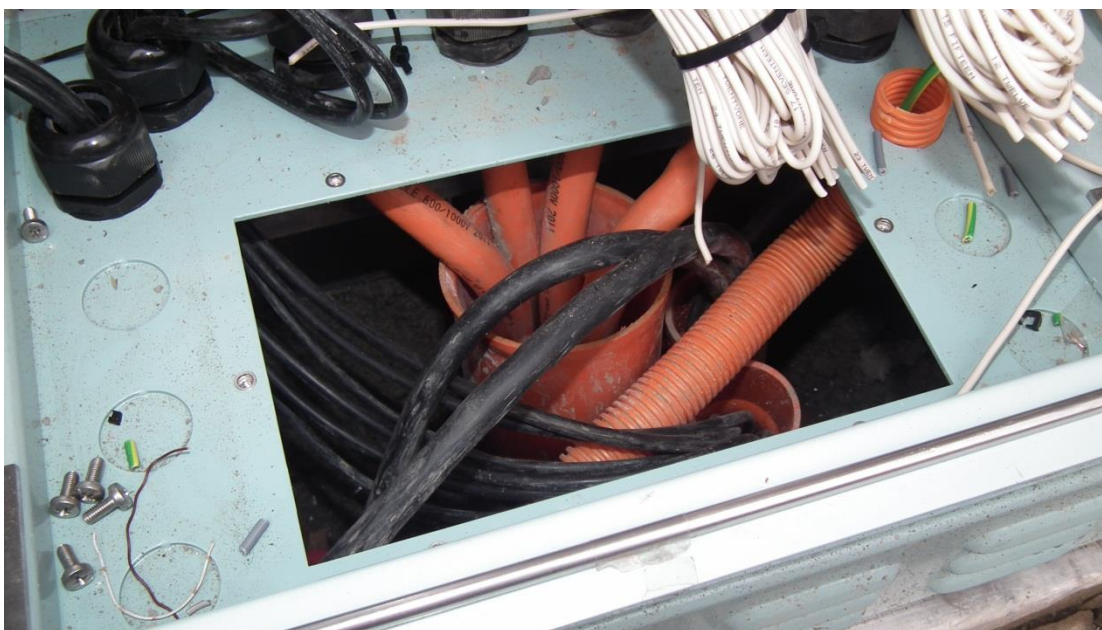

**Figure L02 -Bottom of controller cabinet with gland plate access panel removed**

## APPENDIX M –CYCLE PUSH BUTTONS – INFORMATIVE

(note – alternative units are available with solid cycle symbol instead of red lamp)



Figure M01 – Cycle call accept indicator (no call present).

\* Note – Blanking plate fitted to push button as automatic detection installed.



Figure M02 – Cycle call accept indicator displaying call present.

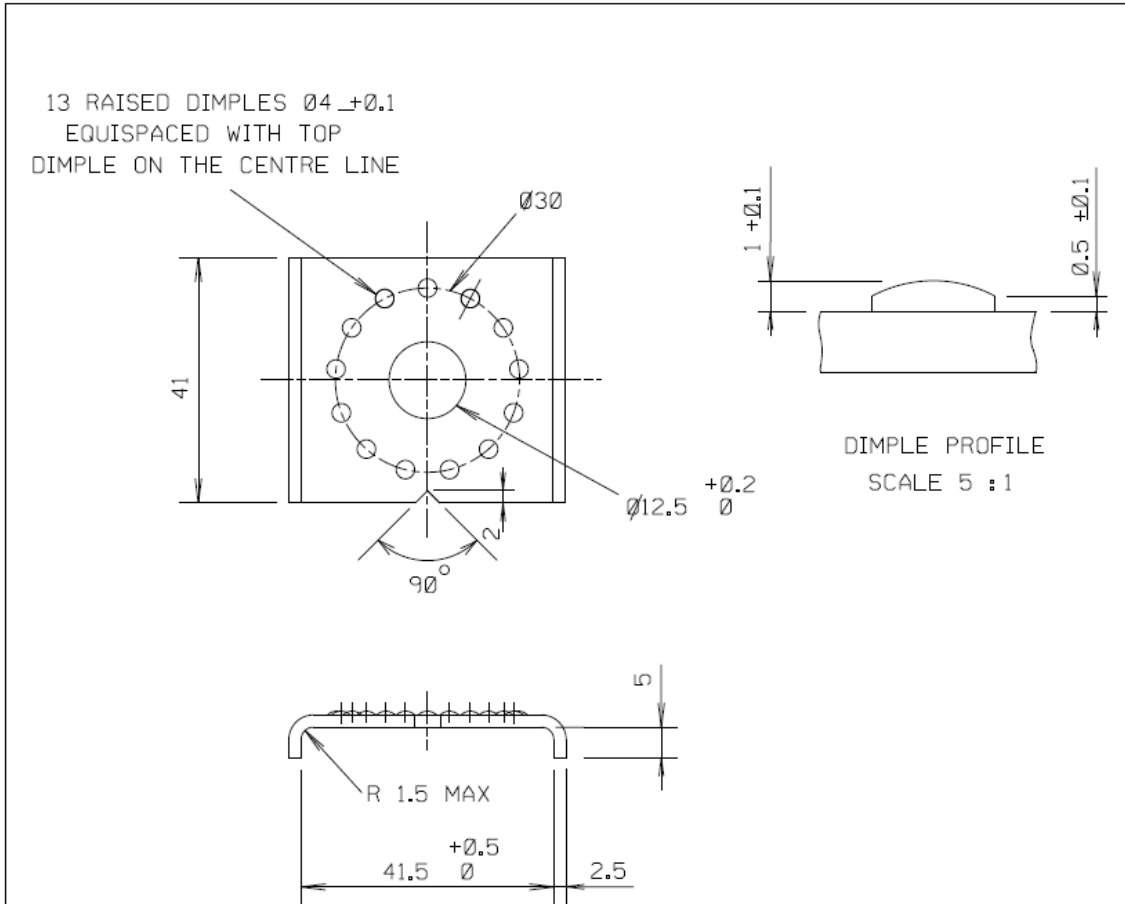

Figure M03 – Cycle call unit with small call accept indicator .

Figure M01, M02, & M03–Cycle Push Buttons

# APPENDIX N – MOUNTING STRAP LOCKING MECHANISM

Figure N01 –Mounting Strap Locking Mechanism



### NOTES

1. REMOVE SHARP EDGES & CORNERS.
2. MATERIAL: STAINLESS STEEL GRADE 304 2B DULL.
3. FINISH: NATURAL.
4. TOLERANCE UNLESS OTHERWISE STATED:
  - GENERAL DIMENSIONS  $\pm 0.5\text{mm}$
  - ANGULAR  $\pm 1^\circ$

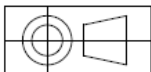

DIMENSIONS IN MILLIMETRES

A ORIGINAL ISSUE	B ISSUE 19-06-95 J/I TC 2710 THICKNESS 2.5 WAS 2 & 'Vee' POSITION ALTERED. EB RVC BWT	C ISSUE 09-08-95 J/I TC2728 LENGTH WAS 42. WIDTH WAS 41. TOLERANCES ADDED RVC BWT	D ISSUE 05-03-96 J/I TC2802 CAT NO PUT ON PLAN. RVC BWT	E ISSUE 23-04-96 J/I TC2817. WIDTH WAS 41.3 + 0.2 - 0. R 1.5 MAX ADDED. RVC BWT	REFERENCE DRAWINGS	
					MOUNT STRAP	VM012-7
					LOWER MTG BKT	VM200-14
					RTA SUPPLY CAT NO 18233542	
ROADS AND TRAFFIC AUTHORITY OF NSW TRAFFIC SIGNALS			SCALE 1:1 OR AS SHOWN		APPROVED: T YUNG MANAGER STDS & QUALITY	
STANDARD LOCK WASHER FOR LANTERN MOUNTING STRAP AND LOWER MOUNTING BRACKET			SUPERSEDES:		ISSUE	
			DRAWN	EB 7-03-95		
			CHECKED	BWT		
			PASSED	BWT 17-05-95	VM200-24	



## APPENDIX O – UPS PRIORITISATION CHART

Factors	Description	Weighting	Max Points	Total
<b>Intersection Factors</b>				
a. Intersection Legs	Where an intersection has more than 4 legs, add 1 point	20	1	20
b. Right Turn Bays	For each right turn lane at the intersection, add 1 point (maximum 4)	2.5	4	10
c. Geometry	Where an intersection has poor sight distance, e.g. irregular horizontal geometry or steep gradients, add 1 point	15	1	15
d. Speed	Where the posted speed limit of any leg is equal or greater than 60km/h, add 1 point	25	1	25
e. AADT	Where the total AADT of the intersection exceeds: 10,000, add 1 point; 20,000, add 2 points; 30,000, add 3 points; 40,000, add 4 points	10	4	40
f. Pedestrians / Cycles	If the combined pedestrian / cyclist count exceeds 100 in any hour, add 1 point	25	1	25
<b>Historical Factors</b>				
g. Power Outage	For each power related signal outage longer than 15 minutes within the last 5 years, add 1 point (maximum 5)	10	5	50
h. Crashes	For each serious or fatal crash within the last 5 years at the intersection, add 1 point (maximum 3)	20	3	60
<b>Proximity Factors</b>				
i. Rail Crossing (inc Lightrail)	If there is a rail grade crossing within 50m of the intersection, add 1 point	10	1	10
j. Children	If the signals are heavily used by children (e.g. proximity to a school), add 1 point	30	1	30
k. Other Traffic Signals	If another signalised intersection is not within 3km of the intersection, add 1 point	10	1	10
<b>Other Factors</b>				
l. Evacuation / Emergency Route	If the intersection is on an evacuation or emergency route, add 1 point	40	1	40
m. Truck Route	If the intersection is on a main truck route, add 1 point	5	1	5
n. Non – Filter RT	If the intersection has non-filter RT across multiple lanes add 1 point	10	1	10
<b>Total</b>				<b>350</b>

Where the total exceeds 150, provision of a UPS system is highly recommended.

Where the total exceeds 100, provision of a UPS system should be considered.

Where the total does not exceed 100, provision of a UPS system is not considered to be warranted.

**Table O01 – UPS Prioritisation Chart**

# APPENDIX P – UPS LINE-INTERACTIVE TOPOLOGY

Figure P01 – UPS Line-Interactive Topology (as per AS5715:2015 Figure 3.2)

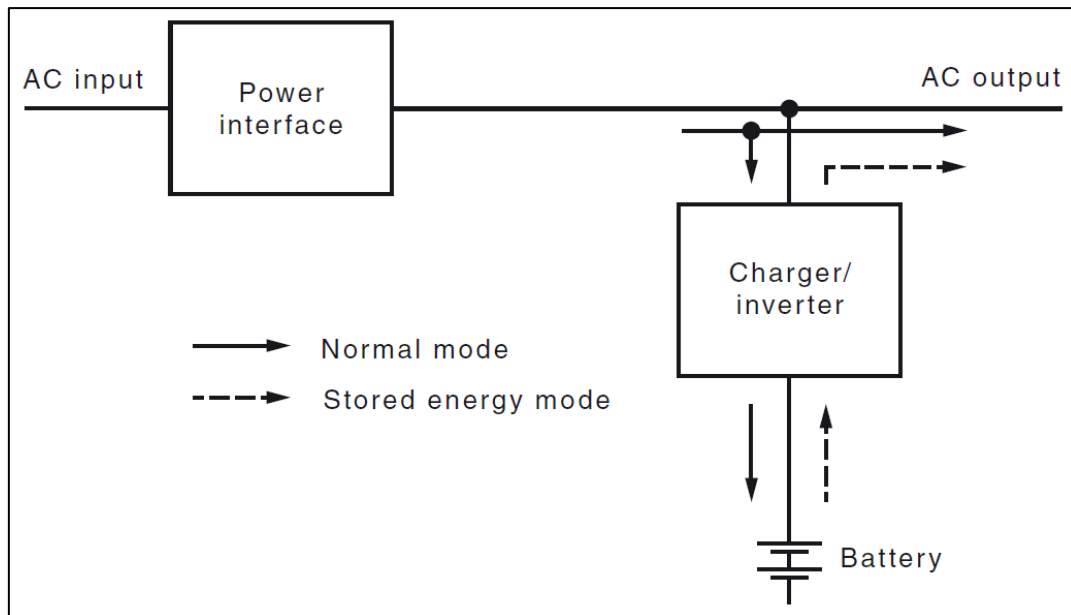

## APPENDIX Q – MINIMUM UPS OUTPUTS

The following table is the minimum UPS Outputs (as per AS 5715:2015 Clause 4.6)

- UPS operating mode (normal, stored energy, bypass).
- Mains present indication, including display of the actual input voltage.
- Battery capacity available (as a percentage).
- Battery run-time remaining for connected load.
- UPS output voltage.
- UPS output current.
- UPS output power (real power, apparent power).
- Battery voltage.
- Battery current.
- Battery temperature.
- Alarms complete with date/time stamps in reverse chronological order.
- Status and event displays with date/time stamps in reverse chronological order.
- Set point views of UPS adjustable parameters.

**Note:** The accuracy of measured values displayed shall be within  $\pm 2\%$  of the real value.

The control panel shall provide the following control operations:

- Start up UPS.
- Shut down UPS.
- Select UPS mode of operation (normal, stored energy, bypass).
- Perform internal diagnostic checks.
- Setting the real-time clock, including setting the times and dates for daylight saving time changes.
- Adjust set point values for all adjustable parameters.

The UPS shall provide non-volatile memory for the storage of all of its logs, test data, configuration settings and user accounts. User passwords shall be stored in an encrypted form.

An event and alarm log shall be provided to store a minimum of 100 individual records.

Log entries shall include the following:

- Start up.
- Shut down.
- Mains lost.
- Mains recovered.
- Overload.
- Bypass operation.
- Operation mode changes.
- Battery test.

- Internal diagnostic checks.
- Over temperature (battery or UPS).
- Inverter failure.
- Charger failure.
- Low battery.
- Cooling fan failure.