

1 SIGNAL POST ELEVATION
SCALE 1:10

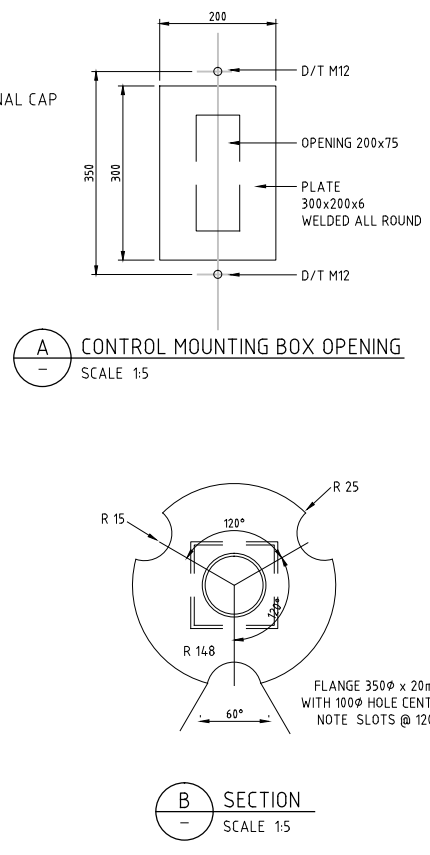

B SECTION
SCALE 1:5

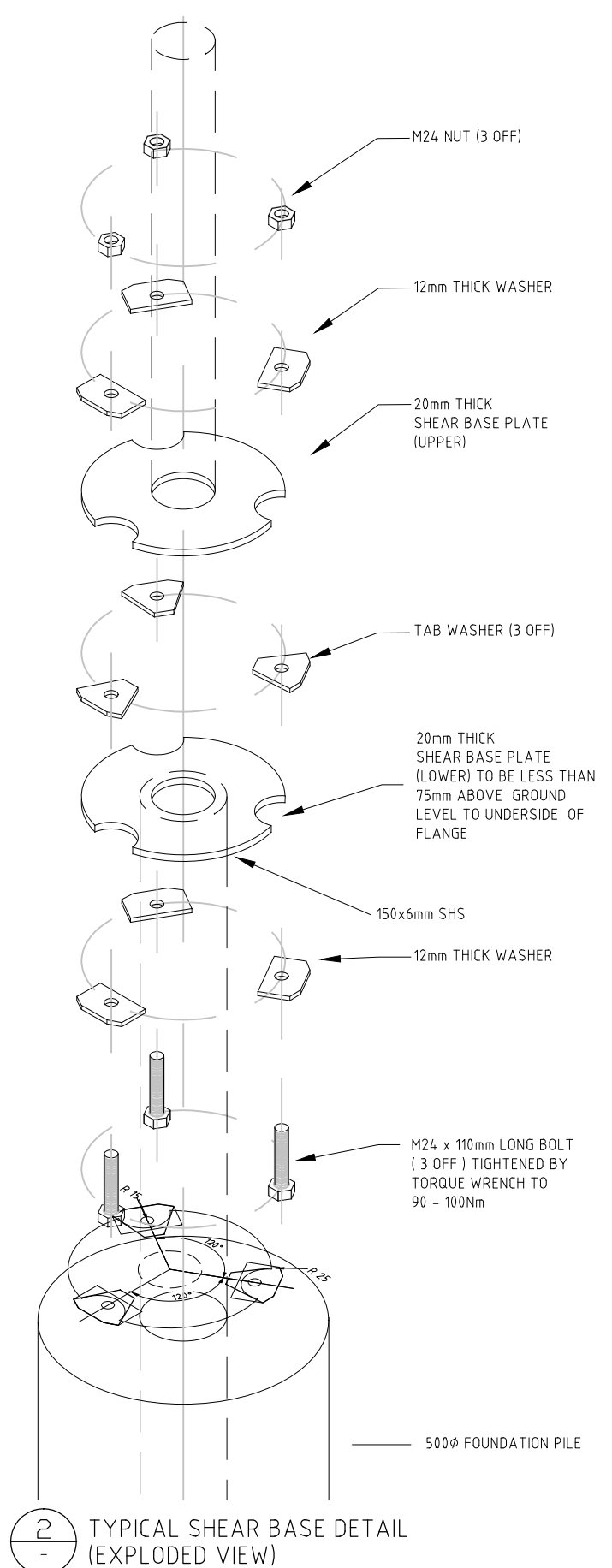

2 TYPICAL SHEAR BASE DETAIL (EXPLODED VIEW)
NOT TO SCALE

NOTES

1. ACTUAL SIZE CONDITIONS TO BE CONFIRMED BY ENGINEER.
2. BASE PLATE - MOUNTED POST SHALL BE PROVIDED WITH A STEEL BASE PLATE IN ACCORDANCE WITH THE REQUIREMENTS OF AS 1798.
3. BASE PLATE SHALL BE WELDED ONTO THE POST IN SUCH A MANNER THAT THE STRENGTH OF THE JOINT IS AT LEAST EQUIVALENT TO THAT OF THE STEEL POST.
4. WELDING PRACTICE SHALL COMPLY WITH THE REQUIREMENTS OF AS 1554.1
5. THREADED PORTION OF ALL RAG BOLTS TO BE COATED WITH GRAPHITE GREASE OR SIMILAR BEFORE ASSEMBLY.
6. ALL EXPOSED PARTS TO BE HOT DIP GALVANISED STEEL.
7. ALL BOLTS, WASHERS + NUTS TO BE GALVANISED.

DESIGN PARAMETERS

1. ABOVE SIGNAGE HAS ADEQUATE STRENGTH AND DURABILITY AND CAPABLE OF TRANSFERRING ALL DESIGN LOADS TO THE FOUNDATION.
2. ALL FOUNDATION IS FOUNDED ON GOOD GROUND (AS DEFINED IN NZS 3604) - 150 KPA ULS BEARING (EQUIV. CBRx7)
3. SOIL SKIN FRICTION TO BE GREATER THAN 25 KPA
4. NOMINAL CONCRETE STRENGTH OF MIN 20 MPA, STEEL STRENGTH "D" OF MIN 300 MPA.
5. REGIONAL WIND SPEED, V100= 41 m/s (REGION A) AS PER AS1170
6. TERRAIN CATEGORY 2 (FOR WIND LOAD DERIVATION)
7. FOUNDATION DEPTH MEASURE FROM CLEARED GROUND LEVEL.
8. NO UNDERGROUND SERVICES WITHIN THE ZONE OF INFLUENCE OF THE SIGN FOUNDATION.

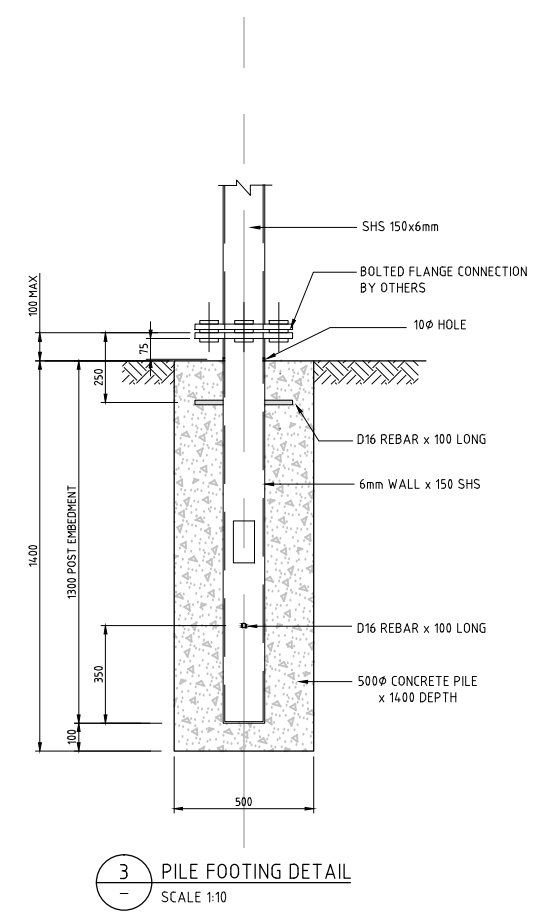

3 PILE FOOTING DETAIL
SCALE 1:10

DISCLAIMER: SEE SHEET 000-0000-0-7104-00

	BY	CHECKED	DATE
DESIGN			JUL 11
DRAWN	PTA		7/11
APPROVED	S.D. HEWETT		7/11
R1 ITS STANDARDS UPDATE	TLH	13/2/15	This drawing and its contents are the property of Opus International Consultants Limited. Any unauthorised employment or reproduction, in full or in part, is forbidden.
AMENDMENT	APP'D	DATE	



Auckland Office

PO Box 5848
Auckland, New Zealand

Tel: +64 9 355 9500
Fax: +64 9 355 9585

OPUS
INTERNATIONAL CONSULTANTS

TITLE						
NZ TRANSPORT AGENCY INTELLIGENT TRANSPORT SYSTEM STANDARDS STANDARD DETAILS						
STANDARD SIGNAL POLE WITH SHEAR BASE						
STATUS	STANDARD	FILE	000-0000-0-7104-19-R1			
SCALE	PLOT DATE	FEATURE IDENTIFIER	CODE	SHEET	REVISION	
	27/05/15 @ 15:30	1/1061/370	7104	19	R1	