

SECTION

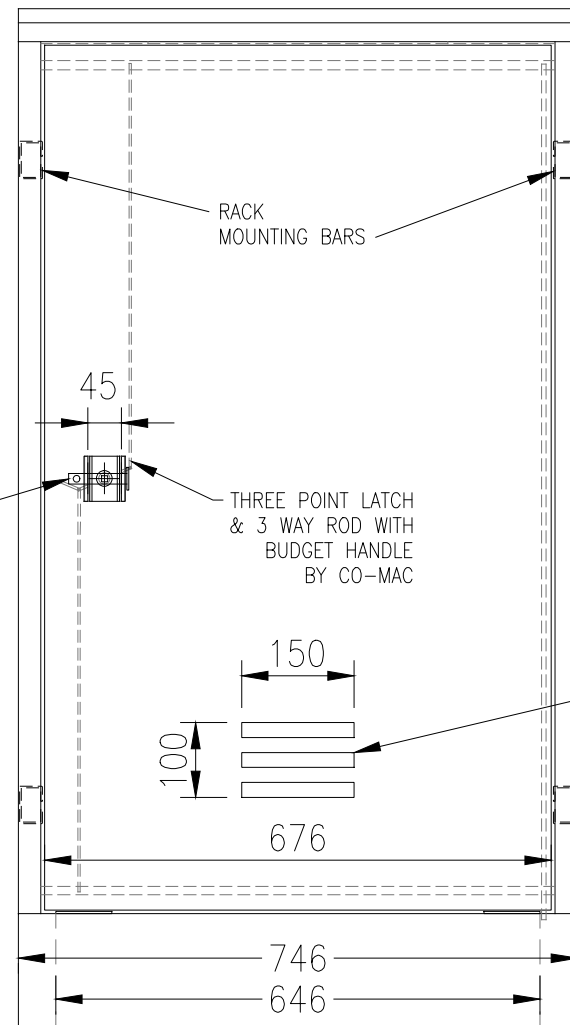

FRONT ELEVATION

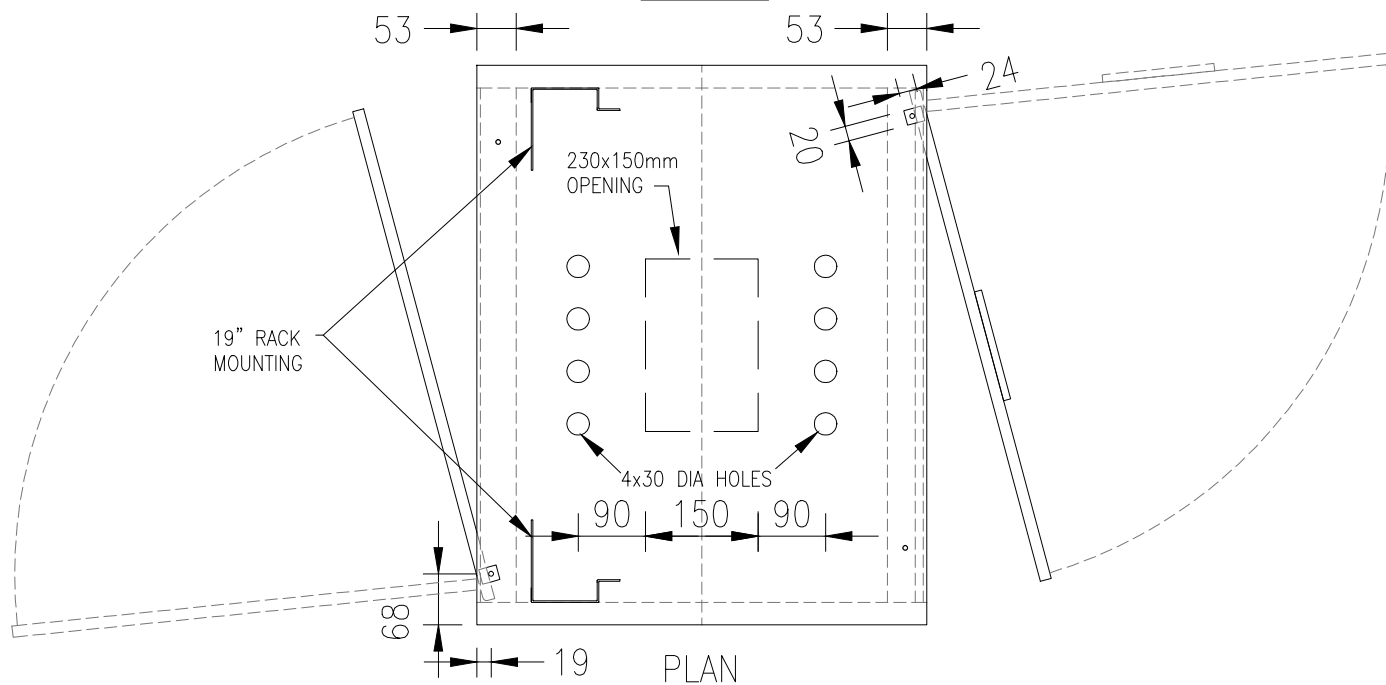

PLAN

NOTES:

CABINET IS TO BE DIPPED FOR 5 MINS IN RIDOLINE 43 AND THEN WASHED IN WATER. THEN DIPPED FOR FIVE MINUTES IN BONDERITE 723 A & B AND THEN WASHED IN WATER AND THEN DRYED IN AN OVEN AT 200°C FOR 15 MINUTES. THEN POWDER COAT USING DULUX 'DURALLOY 9042, COLOUR KARAKA GREEN.

LATCH TO BE 3 POINT LATCH, 3 WAY ROD SYSTEM BY CO-MAC AND KEY TO BE "T" KEY BY CO-MAC.

VENTILATION GRILL WITH ANT PROOF GAUZE MESH IN FRONT DOOR

4X3mm THICK FIXING PLATES BOTH TOP AND BOTTOM

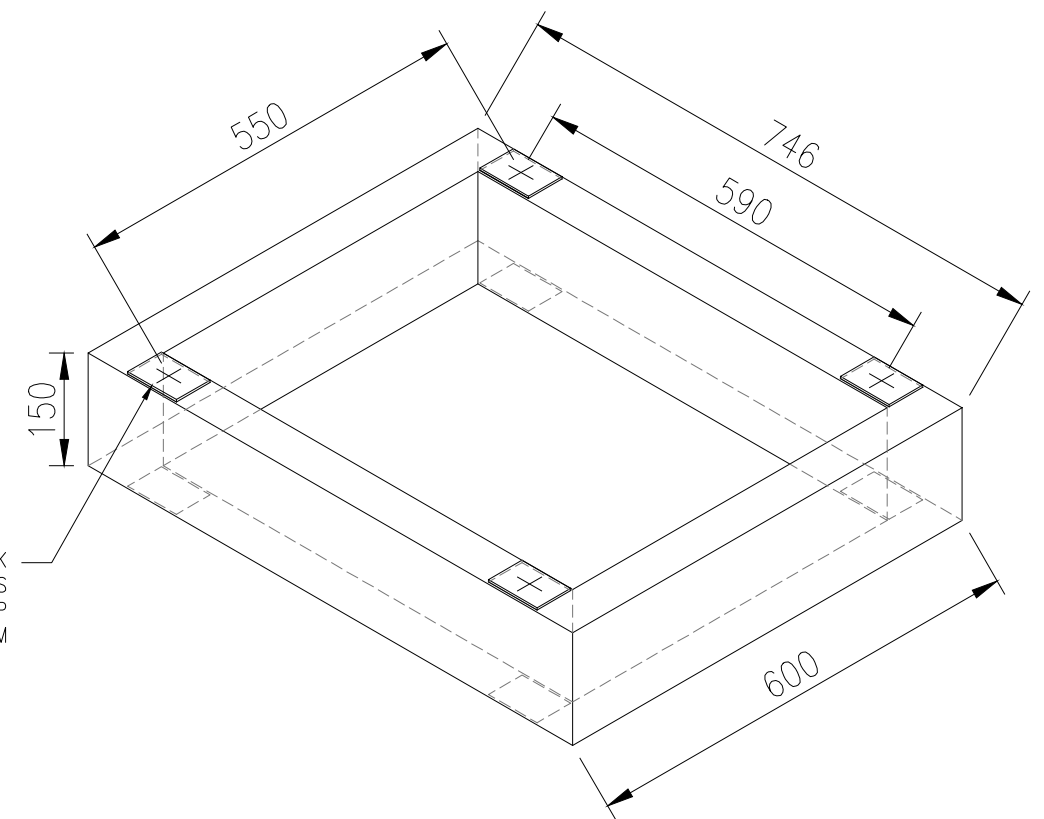

BOLT DOWN CHANNEL BASE

DISCLAIMER: SEE SHEET 000-0000-0-7104-00

	BY	CHECKED	DATE
DESIGN	T.L. HARRIS		7/02
DRAWN		LJC	
REC'D	T.L. HARRIS	7/02	10/8/11
APPROVED	S.D. HEWETT		8/11
R1 ITS STANDARDS UPDATE	TLH	13/2/15	This drawing and its contents are the property of Opus International Consultants Limited. Any unauthorised employment or reproduction, in full or in part, is forbidden.
AMENDMENT	APP'D	DATE	



Auckland Office

PO Box 5848
Auckland, New Zealand
Tel: +64 9 355 9500
Fax: +64 9 355 9585

TITLE						
NEW ZEALAND TRANSPORT AGENCY INTELLIGENT TRANSPORT SYSTEMS STANDARD						
ROADSIDE CONTROL CABINET						
STATUS	STANDARD	FILE	000-0000-0-7104-03-R1			
SCALE	PLOT DATE	FEATURE IDENTIFIER	CODE	SHEET	REVISION	
AS SHOWN	13/02/15 @ 09:31	1/1061/370	7104	03	R1	