

# Appendix B: Bridge Side Protection

## **Table of Contents**

B1	General .....	B-3
B2	Types of Side Protection and their Applications .....	B-3
	B2.1 Non-Rigid Barrier .....	B-4
	B2.2 Rigid Barrier .....	B-4
	B2.3 Pedestrian Barrier .....	B-4
	B2.4 Combination Pedestrian/Traffic Barrier .....	B-5
	B2.5 Kerb .....	B-5
B3	Barrier Performance Selection Method .....	B-5
	B3.1 Performance Levels .....	B-6
	B3.2 Adjusted AADT Method for Barrier Performance Level 3, 4 and 5 Selection .....	B-8
B4	Barrier Acceptance Criteria .....	B-10
B5	Standard Solutions .....	B-10
B6	Side Protection Design Criteria .....	B-18
	B6.1 Equivalent Lateral Forces and Height of Application for Rigid Traffic Barriers .....	B-18
	B6.2 Design of Deck Slabs to Resist Barrier Forces .....	B-19
	B6.3 Pedestrian and Cyclist Barrier .....	B-20
	B6.4 Combination Pedestrian / Traffic Barrier .....	B-20
	B6.5 Kerb .....	B-20
	B6.6 Deck Adjacent to Non-Rigid or Rigid Barrier .....	B-20
B7	Geometric Layout, End Treatment & Transitions - Transit New Zealand Requirements .....	B-21
	B7.1 Rigid Barrier .....	B-21
	B7.2 Non-Rigid Barrier Installation .....	B-21

B7.3	Bridge Approaches .....	B-21
B7.4	End Treatment .....	B-22
B7.5	Kerb .....	B-22
B8	Barrier Performance Level 3 Standard Designs - Transit New Zealand Requirements for Bridge Guardrail.....	B-22
B8.1	Bridge Guardrail.....	B-22
B8.2	Guardrail Layout .....	B-23
B8.3	Bridge Guardrail Performance .....	B-23
B8.4	Bridge Guardrail Length Changes and Anchorage - Transit New Zealand Requirements.....	B-24
B9	References .....	B-25

## **B1 General**

This Appendix provides a method for determining appropriate Barrier Performance Levels and guidance on types of side protection, their application and design. The following is a summary of the topics covered:

- B2 Types of Side Protection and their Applications
- B3 Barrier Performance Selection Method
- B4 Barrier Acceptance Criteria
- B5 Standard Traffic Barrier Solutions
- B6 Side Protection Design Criteria
- B7 Geometric Layout (End Treatment and Transitions)
- B8 Barrier Performance Level 3 Standard Designs (Bridge Guardrail)

Median barriers on separated structures shall be treated as side protection, but the barrier level provided shall not be less than the median barriers on the approaches to the bridge.

## **B2 Types of Side Protection and their Applications**

Side protection shall consist of one of the alternatives listed below for each situation except where a 'No Barrier' solution is deemed acceptable in accordance with Section B3.1.6. The required Barrier Performance Level and subsequent barrier selection shall be in accordance with Sections B3 (traffic) and B2.3 (pedestrian). Barrier applications for specific situations are:

### **(a) Traffic Lane adjacent to deck edge:**

- Non-Rigid Barrier
- Rigid Barrier (concrete or metal post and rail)
- Kerb with 500mm wide verge and Combination Pedestrian/Traffic Barrier at the outer edge.

### **(b) Traffic Lane adjacent to footpath:**

- Non-Rigid Barrier between the carriageway and the footpath, with a Pedestrian Barrier at the outer edge of the footpath
- Rigid Barrier (concrete or metal post and rail) between the carriageway and the footpath, with a Pedestrian Barrier at the outer edge of the footpath
- Kerb, with Combination Pedestrian/Traffic Barrier at outer edge of footpath.

### **(c) Footpath:**

- Pedestrian Barrier at the outer edge and a Non-Rigid Barrier or Rigid Barrier at the inner edge
- Combination Pedestrian/Traffic Barrier at the outer edge with a Kerb at the inner edge.

The standard cross-sections shown in Figure A1 illustrate various possible combinations of these alternatives.

Applications and design criteria for each alternative are given below.

### **B2.1 Non-Rigid Barrier**

A Non-Rigid Barrier is defined as a post and continuous rail system which restrains vehicles by absorbing energy during deformation of the system and of the vehicle.

### **B2.2 Rigid Barrier**

A Rigid Barrier is defined as a barrier designed so that there will be no movement of the device, other than elastic straining during a crash involving the design vehicle. They include continuous concrete barriers and metal post and rail systems that behave in a rigid manner. Rigid Barriers shall be used in preference to Non-Rigid Barriers in the following situations:

- (i) For architectural consistency, where Rigid Barriers are used on the approaches.
- (ii) Where it is necessary to protect a particularly vulnerable structural element.
- (iii) Where deflection of a Non-Rigid Barrier system cannot be accommodated.

### **B2.3 Pedestrian Barrier**

A Pedestrian Barrier is defined as a post and rail system that restrains pedestrians. Pedestrian Barriers may be of two types, subject to compliance with requirements of the current Building Act:

- General type, which consists of a series of posts supporting a top rail, below which is any system of members between which the spaces are not more than 300 mm in at least one direction.
- Vertical bar type, which consists of a series of posts supporting a top rail, below which are vertical bars spaced apart not more than 130 mm. The vertical bars shall be attached only at the top and bottom.

Pedestrian Barriers shall be used at the outer edge of footpaths as specified in Figure B1B. The vertical bar type shall be used in the following situations:

- (i) In locations where children less than six years of age are expected to frequent the bridge.
- (ii) Where the bridge crosses over building properties, city streets, main highways, motorways, or railways.
- (iii) Where the footpath is at a general height of more than 5 m above ground or water level.
- (iv) Where the volume of pedestrian traffic is exceptionally heavy or likely to become so.
- (v) Where there are circumstances likely to cause alarm to pedestrians, such as a river prone to violent, rapid flooding, that demand a higher level of pedestrian protection be provided.

The general type may be used elsewhere.

### **B2.4 Combination Pedestrian/Traffic Barrier**

A Combination Pedestrian/Traffic Barrier shall satisfy the requirements for a pedestrian barrier, (refer Section B6), with the traffic barrier portion of the combination satisfying the appropriate traffic Barrier Performance Level.

A Combination Pedestrian/Traffic Barrier shall be used in accordance with Figure B1B at the outside edge of a footpath when a kerb is the only separation of a footpath from the carriageway.

### **B2.5 Kerb**

A kerb is defined as a low barrier that protects pedestrians by restraining the wheels of vehicles. A kerb shall always be associated with a footpath equal to or exceeding 1.3 m in width when no other form of traffic barrier separates the carriageway from the footpath.

A kerb can be used on a bridge in any of the following situations:

- As the sole separation of a footpath from the carriageway only where the posted speed limit is 70 km/h or less.
- Where there is also a kerb on the bridge approaches.
- When required to prevent rainwater runoff from discharging over the edge of the bridge deck.

The kerb profile on the bridge shall match that on the approaches, except as necessary to comply with the shape requirements below and shall be used in the locations indicated in Figure A1 of Appendix A.

The kerb height above the road surface shall be between 150 and 200 mm. There shall be a vertical face over at least the upper 100 mm of its height, and no projection below that. The preferred kerb shape is illustrated below:

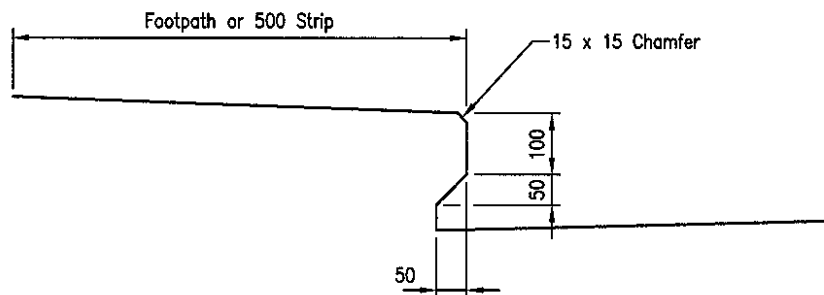

### **B3 Barrier Performance Selection Method**

A risk management approach as specified in AS/NZS 3845<sup>(1)</sup> shall be used to determine the appropriate Barrier Performance Level at a bridge site. The *NCHRP Report 350*<sup>(2)</sup> test level corresponding to each Barrier Performance Level is presented in Table B1.

**Table B1 – Barrier Performance Levels and Equivalent NCHRP Report 350 Test Levels**

Barrier Performance Level	Equivalent NCHRP Report 350 Test Level
SPECIAL	No Equivalent Test
6	TL-6
5	TL-5
4	TL-4
3	TL-3

This method applies to barriers for new bridges and replacement barriers for existing bridges. It provides a barrier selection method based on a risk approach that encompasses traffic conditions and the bridge environment. Figure B1A is to be followed for the selection of an appropriate barrier at a particular bridge location. The method is based on the Draft Austroads *Bridge Design Code*<sup>(3)</sup> and AASHTO (1989) *Guide Specification for Bridge Railings*<sup>(4)</sup> with minor amendments for New Zealand conditions.

### **B3.1 Performance Levels**

#### **B3.1.1 Special Performance Level**

A Special Performance Level, non-penetrable barrier shall only be provided at specific locations where agreed by the Road Controlling Authority, where vaulting by high mass and high centre of gravity vehicles must be prevented. Such a barrier shall be considered if the commercial traffic count and at least two of the site conditions stated in Section B3.1.2 apply at the same time, subject to benefit-cost justification. There is no equivalent *NCHRP Report 350*<sup>(2)</sup> test level for this performance level. A 44t articulated heavy commercial vehicle (HCV) shall be the controlling vehicle in determining barrier strength with the remaining test requirements as per TL-6 (NCHRP-350<sup>(2)</sup>).

#### **B3.1.2 Barrier Performance Level 6**

A Barrier Performance Level 6 barrier shall only be provided at specific locations where agreed by the Road Controlling Authority, where there is a high probability of loss of life or serious injury due to a vehicle penetrating the barrier. A Barrier Performance Level 6 barrier shall be considered if:

The volume of heavy commercial vehicles (refer B3.2.4 for definitions) passing over the bridge equals or exceeds the following values:

- 2000 heavy commercial vehicles per day on roads with a speed environment > 60 km/h, or
- 4000 heavy commercial vehicles per day on urban roads with a speed environment > 60 km/h.

And any of the site conditions in (i), (ii) and (iii) apply.

- (i) Bridges over major roads with an AADT of 10,000 vpd/lane, or over roads with an AADT of 40,000 or more vehicles per day.
- (ii) Bridges over electrified railways, or over goods lines carrying significant quantities of either noxious or flammable substances.
- (iii) Bridges over high occupancy land such as houses, factories, areas for congregating, etc.

Or, any of the conditions (iv), (v) and (vi) apply, subject to an appropriate benefit-cost analysis justification to the *Transfund Project Evaluation Manual*<sup>(5)</sup>.

- (iv) Bridges more than 10 metres high.
- (v) Bridges over water greater than 3 metres deep.
- (vi) Bridges on horizontal curves with a radius of 600m or less.

The AADT referred to above is the estimated construction year AADT. (Refer to Section B3.2 for further explanation of this).

The equivalent *NCHRP Report 350*<sup>(2)</sup> Test Level for Barrier Performance Level 6 barriers is TL-6.

### **B3.1.3 Barrier Performance Level 5**

A Barrier Performance Level 5 barrier may be provided at specific locations where agreed by the Road Controlling Authority, for the containment of buses and medium mass vehicles on high speed carriageways, major carriageways, and urban roads with a medium to high level of mixed heavy vehicles, and site specific risk situations.

### **B3.1.4 Barrier Performance Level 4**

A Barrier Performance Level 4 barrier is generally provided for the appropriate containment of cars, heavy utilities and light to medium mass commercial vehicles on main carriageways.

### **B3.1.5 Barrier Performance Level 3**

A Barrier Performance Level 3 barrier is generally provided for the safe containment of light vehicles. These barriers shall generally be used for:

- bridges on rural roads with low volume traffic
- bridges in low speed environments
- short bridges with low height above ground, or shallow water.

### B3.1.6 No Barrier Option

For certain bridge or culvert sites, conditions may be such that barriers may constitute a higher risk than not providing any barrier. Barriers may be omitted where all the following conditions are satisfied:

- the bridge or culvert is less than 1.5m above the ground
- traffic volumes are less than 150 vehicles per day
- the radius of curvature at the bridge site is greater than 1500m and the road approaches have a sight distance greater than the stopping distance
- the location is rural and without provision for pedestrian traffic
- conditions under and near the bridge do not increase the level of risk to the occupants of the vehicle leaving the bridge
- water beneath the bridge is less than 1m deep.
- the bridge is less than 5m long and the deck extends at least 1.2m beyond the carriageway edge.

Or, when the edge of the bridge or culvert is greater than 9 metres from the edge of the carriageway, or when the cross sectional area of a culvert is less than 3.5 m<sup>2</sup> and with ends flush with the embankment batter.

## B3.2 Adjusted AADT Method for Barrier Performance Level 3, 4 and 5 Selection

### B3.2.1 General

Once it has been determined that a barrier is required, other than for a Barrier Performance Level 6 or Special Performance Barrier, the appropriate performance level can be determined using the Adjusted AADT Method outlined below and as indicated in Figure B1A. The method is also described in references <sup>(3)</sup> and <sup>(4)</sup> although it has been adjusted slightly in this Manual to account for New Zealand conditions. This method assumes 2% traffic growth per annum over 30 years.

The Adjusted AADT method shall be used as follows:

- (i) If the estimated traffic growth is 2% per annum then this Section and the charts provided can be used directly.
- (ii) For growth rates other than 2% per annum the construction year AADT for use in this Section can be estimated by dividing the 30-year after construction AADT by 1.81. The error in using this estimation is acceptable and within the assumptions of this methodology.

Four factors accounting for risk are used to adjust the estimated traffic volume (AADT) for the bridge at the time of construction. This Adjusted AADT is then used to determine the appropriate Barrier Performance Level.

For sites with a design speed greater than 80km/h the construction year AADT need not be taken as greater than 10,000 vehicles per day per lane (i.e. 40,000 AADT for a 4 lane bridge).



The Adjusted AADT shall be calculated as follows:

$$\text{Adjusted AADT} = RT \times GD \times CU \times US \times \text{AADT}$$

Where: RT = Road type factor, from Figure B2

Road types are:

- Type A: Divided carriageway, or undivided carriageway with 5 or more lanes
- Type B: Undivided carriageway with up to 4 lanes
- Type C: One way (Single lane bridges that cater for traffic travelling in both directions shall be treated as 'one way')

GD = Road grade factor, from Figure B3

This factor is applicable to sites with a down slope approach to the bridge in the direction of the traffic flow.

CU = Curvature factor, from Figure B4

This factor relates to the maximum horizontal curvature of the road alignment at the bridge site, including immediate approaches. For radius of curvature less than 600m refer to Section B3.1.2.

US = Under structure land use and hazard from falling factor, from Figure B5

This factor encompasses two forms of risk: that associated with the vehicle impinging on the land use beneath the bridge, and that to the vehicle occupants associated with falling from height onto the underlying ground or into water.

AADT = Annual average daily traffic in construction year

### **B3.2.2 Under Structure Land Use and Hazard from Falling**

The modification factor graph in Figure B5 plots three risk levels related to land use beneath the bridge structure against the hazard associated with falling. The three land use risk levels are defined as:

**High Risk Land Use** – refers to land where there is significant risk to persons or property due to the land use below the structure. Examples are major roadways, railways, houses, factories, etc.

**Medium Risk Land Use** – refers to land used in such a way that there is an occasional risk to persons or property below the structure, e.g. over roads with a construction year AADT < 10,000 vpd, country rail lines with occasional services, walking trails or areas with occasional human populations.

**Low Risk Land Use** – refers to land used in such a way that there is minimal or insignificant risk to persons or property below the structure e.g. over open fields, bush land, etc.

### **B3.2.3 Final Barrier Performance Level Selection**

The final Barrier Performance Level is selected by comparing the Adjusted AADT with the threshold limits for the appropriate design speed given in Figures B6 to B9. These threshold graphs also include an additional variable to cater for the offset from

the face of the barrier to the edge of the traffic lane, described as rail offset in the charts.

The design speed should be taken as the design speed for new bridges on new highways or new alignments, or the 85 percentile operating speed where a new bridge is replacing an existing structure with no change to the road alignment or where replacement barriers are to be provided to an existing bridge.

#### **B3.2.4 Vehicles and Traffic Mix**

The percentage of commercial vehicles in Figures B6 to B9 includes medium to heavy commercial vehicles. (i.e. MCV to HCV-II as described in the *Transfund New Zealand Project Evaluation Manual*<sup>(6)</sup>).

For locations where the commercial vehicle (MCV to HCV-11) traffic mix exceeds 40% the designer shall determine the appropriate Barrier Performance Level based on a site-specific benefit-cost analysis. The performance level selected shall not be less than that required by these charts.

#### **B4 Barrier Acceptance Criteria**

Only barriers that comply with one of the following three performance criteria shall be used for bridge side protection:

- The barrier system has undergone satisfactory crash testing to the appropriate test level in accordance with NCHRP Report 350 with a maximum deflection not greater than 600mm.
- The barrier system is based on similar crash tested barriers used elsewhere with a maximum deflection not greater than 600mm, subject to Transit New Zealand approval.
- The barrier system is one that is deemed to comply by Transit New Zealand.

Crash testing/performance of the proposed barrier shall be to the appropriate level as determined in Section B3.

The 600mm maximum deflection criteria shall be adopted unless the additional cost of a wider bridge deck can be justified.

#### **B5 Standard Solutions**

Table B2 gives standard non-proprietary solutions that meet the Performance Levels indicated. Equivalent lateral forces for each Performance Level are given in Section B6 for design of the bridge deck for rigid barrier systems, and reinforcement for continuous rigid concrete barrier systems, where the profile has been approved for the appropriate Performance Level. The standard solutions listed are not intended to be a complete list of acceptable solutions. The designer may specify alternative barrier systems subject to the acceptance criteria of Section B4 and elsewhere in this manual.

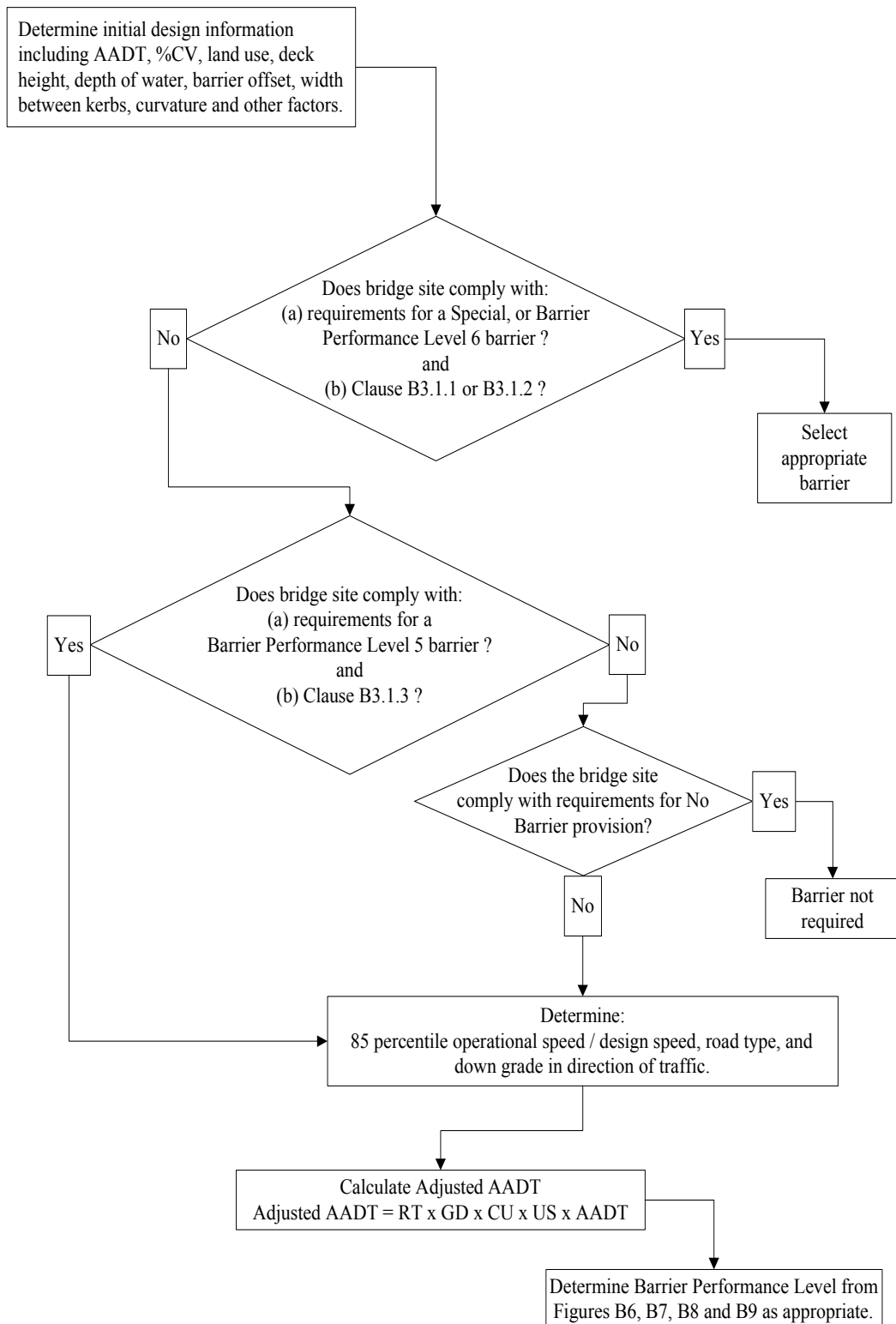

**Figure B1A: Barrier Performance Selection Flow Chart**

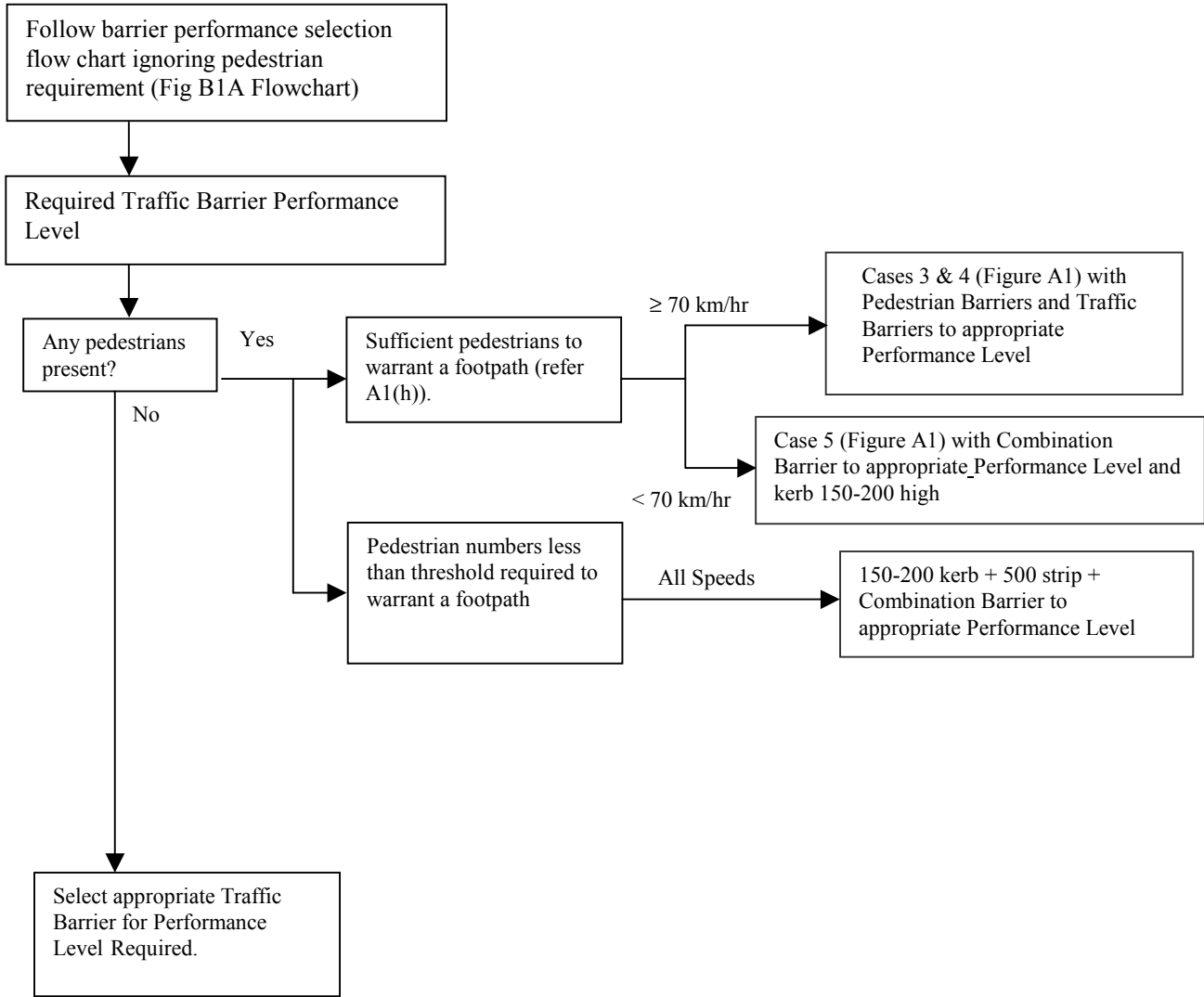
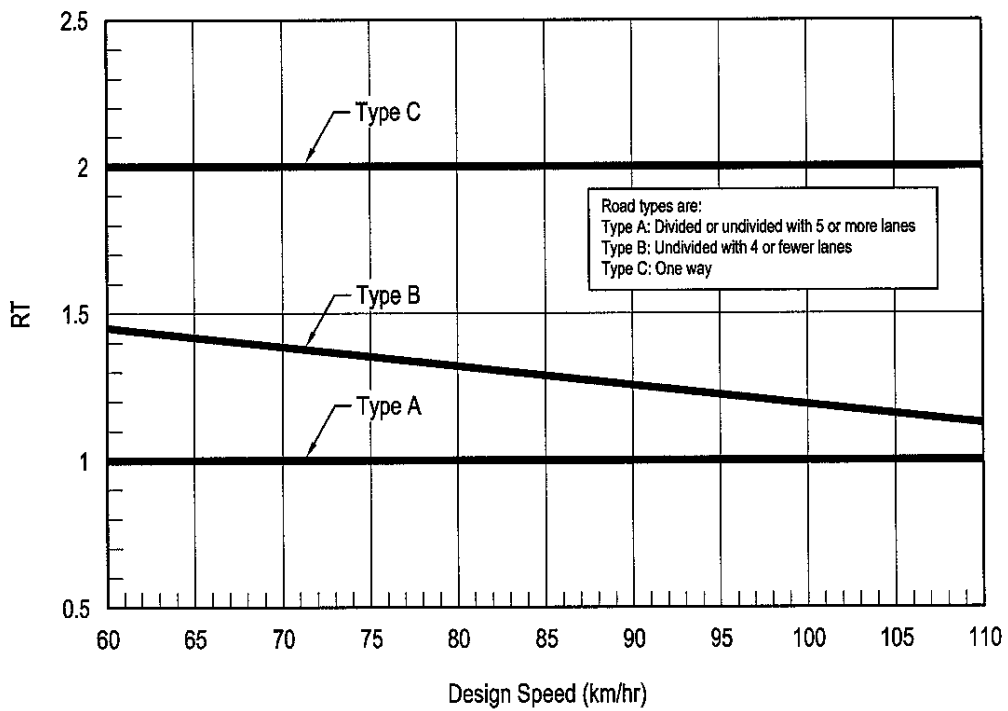
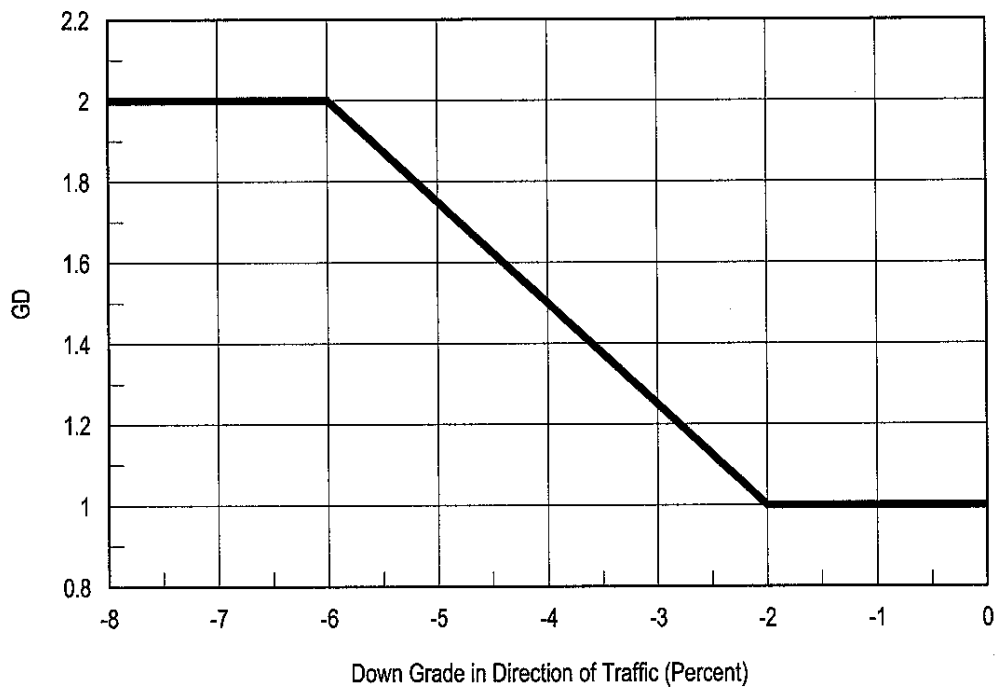

Figure B1B: Pedestrian Barrier Selection Flow Chart



**Figure B2: Road Type Factor**



**Figure B3: Grade Factor**

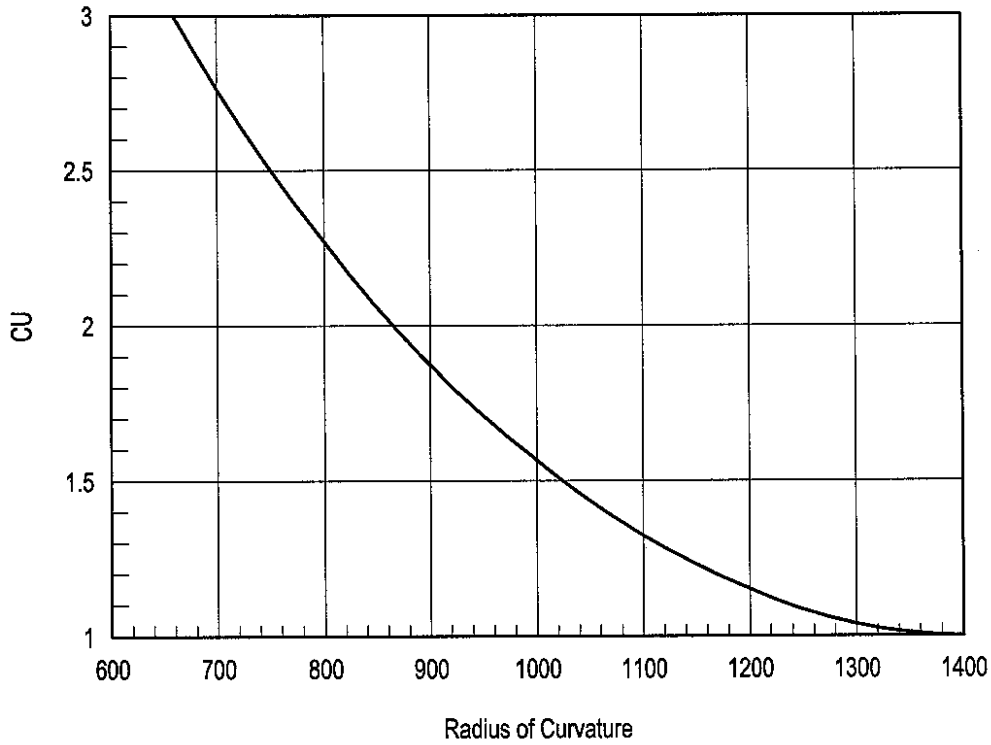

Figure B4: Curvature Factor

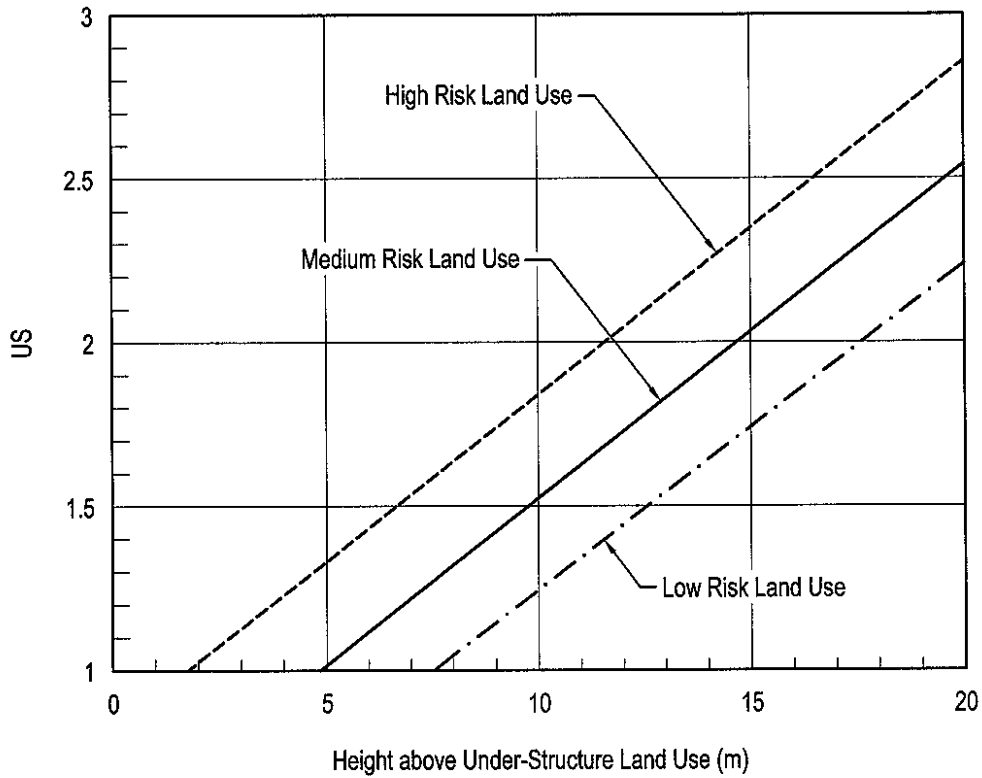
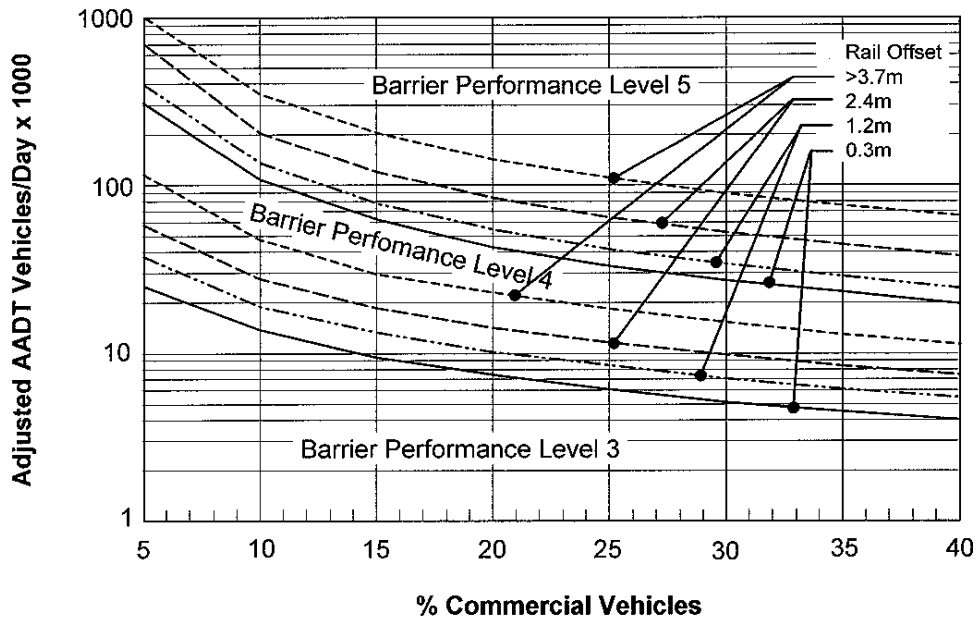

Figure B5: Deck Height and Under Structure Use Factor

**THRESHOLD LIMITS 60 km/hr**



**Figure B6: Threshold Limits 60 km/h**

**THRESHOLD LIMITS 80 km/hr**

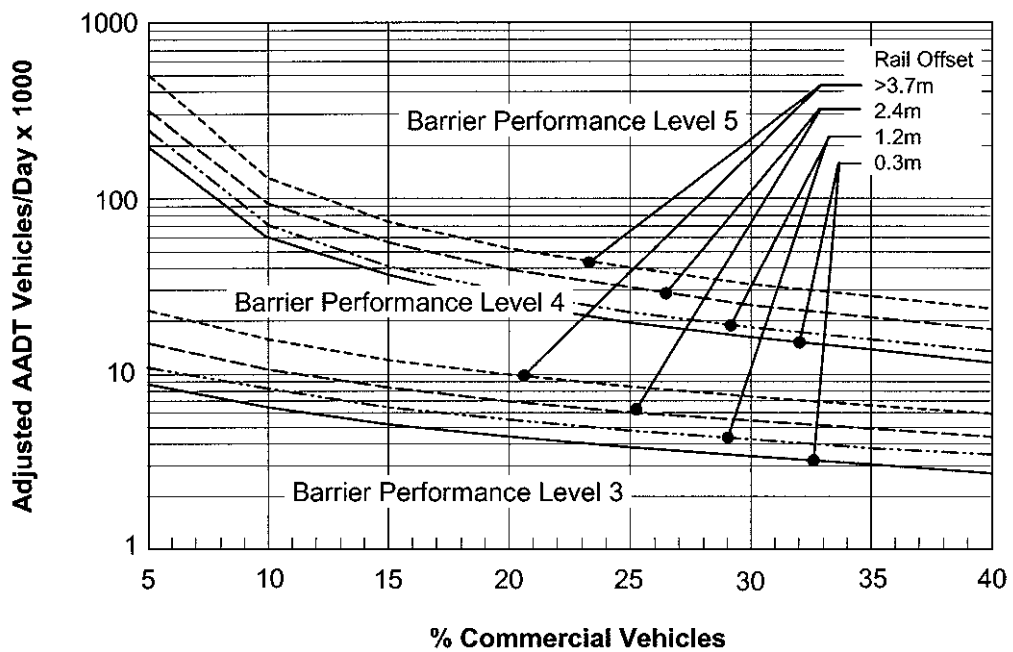

**Figure B7: Threshold Limits 80 km/h**

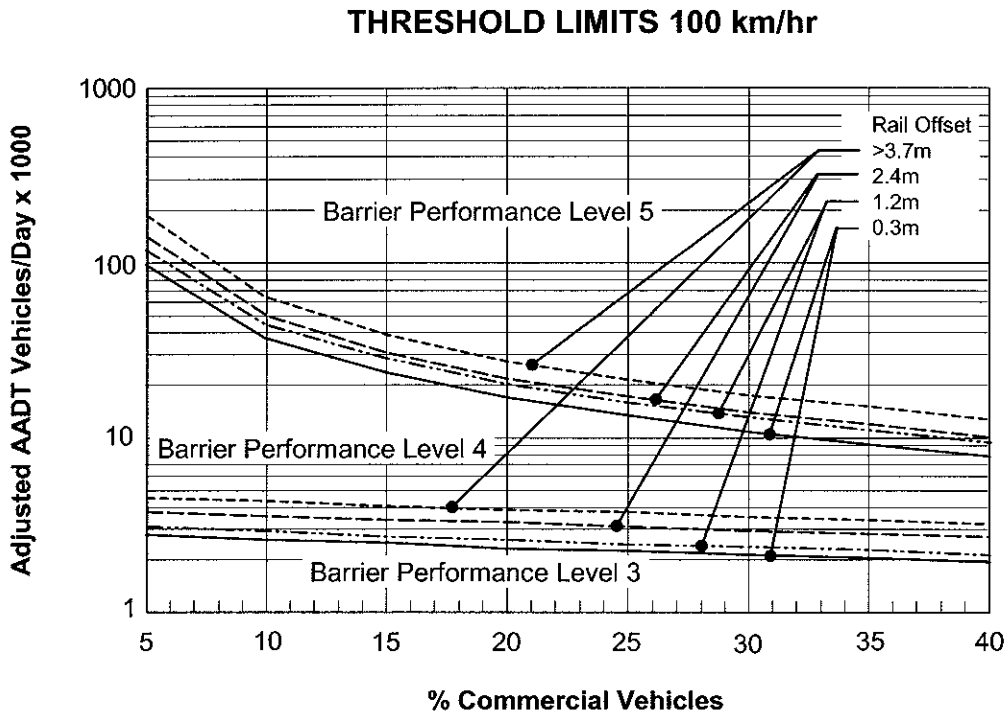

Figure B8: Threshold Limits 100 km/h

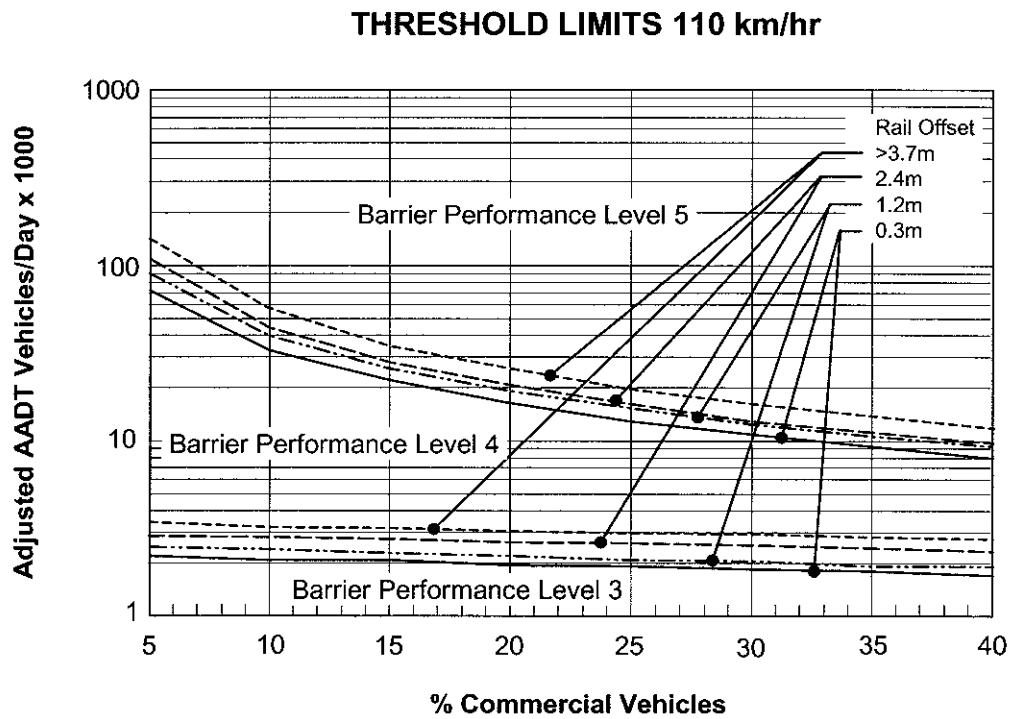

Figure B9: Threshold Limits 110 km/h



**Table B2: Standard Non-Proprietary Solutions**

Barrier Performance Level	NCHRP Report 350 Test Level	Approved Barrier Types	Reference
3	TL-3	(a) W Section Transit Bridge Guardrail (3.4mm thick, grade 500 MPa steel)  (b) G9 Thrie Beam, posts 2.0m centres, 805 high.	Fig B12 and B22  Refer AS/NZS 3845 <sup>(1)</sup> - See Note 2
4	TL-4	(a) 820 High VCB Barrier  (b) 820 High Type F Barrier  (c) Any other FHWA TL-4 approved barrier, subject to Transit approval  (d) G9 modified Thrie Beam with modified blockout, posts 2.0m centres, 865 high	AS/NZS 3845 <sup>(1)</sup> Fig 3.12(6) – See Note 1  AS/NZS 3845 <sup>(1)</sup> Fig 3.12(7) – See Note 1  FHWA web site - See Note 2  Refer AS/NZS 3845 <sup>(1)</sup> - See Notes 3 & 4
5	TL-5	(a) Texas HT barrier modified to F-shape profile. This is the TL-5 barrier preferred by Transit.  (b) Any other FHWA TL-5 approved <sup>(2)</sup> barrier, subject to Transit approval	FHWA web site - See Note 2  FHWA web site - See Note 2
6	TL-6	Any FHWA TL-6 approved <sup>(2)</sup> system, subject to Transit approval	FHWA web site - See Note 2
<b>SPECIAL</b>	<b>Requires Specific Design</b>		

**Notes:**

1. Profile only from AS/NZS 3845<sup>(1)</sup>. For TL-4 to TL-6 reinforcement must be determined using the equivalent lateral forces given in Section B6 of the Bridge Manual.
2. Only barriers that meet the deflection criteria in Section B4. A listing of FHWA approved barriers can be found on the FHWA website at the following URL:  
<http://safety.fhwa.dot.gov/fourthlevel/hardware/bridgerailings.htm>
3. Only where the additional cost of a wider bridge deck can be justified to accommodate deflections greater than 600mm as specified in Section B4.
4. For TL-4 the posts shall be I-sections in accordance with the details shown on drawings PWE01-04 and PWB03. These drawings are available through the internet. URLs for the drawings are:  
 PWE01-04: <http://cee.wpi.edu/roadsafe/hardwareguide/plots/Posts/pwe01-04.pdf>  
 PWB03: <http://cee.wpi.edu/roadsafe/hardwareguide/plots/Posts/pwb03.pdf>  
 Note that on PWB03 the modified spacer block length is incorrectly given as 554mm. The correct length is 432mm.

## B6 Side Protection Design Criteria

### B6.1 Equivalent Lateral Forces and Height of Application for Rigid Traffic Barriers

The forces in Table B3 can be used to determine the reinforcement required in continuous rigid concrete barriers where the profile has been approved for the appropriate Performance Level. The transverse and longitudinal forces shall be applied at height  $H_e$ . The force  $F_v$  shall be applied along the top of the barrier as indicated in Figure B10. All loads shall be applied to the longitudinal barrier elements.

Design of reinforcement for rigid concrete barriers using the forces in Table B3 requires detailed analysis. Loads should be applied uniformly over the specified contact lengths. Design of rigid concrete barriers shall be carried out in accordance with 4.2 of this manual.

Rigid barrier reinforcement details provided in Section 3 of AS/NZS 3845<sup>(1)</sup> shall not be used.

**Table B3 - Barrier Design Loads, Contact Lengths and Effective Heights**

Barrier Performance Level	Transverse Outward Load $F_t$ (kN)	Longitudinal Load $F_L$ (kN)	Transverse and Longitudinal Vehicle Contact Lengths $L_t$ and $L_L$ (m)	Vertical Down Load $F_v$ (kN)	Vehicle Contact Length for Vertical Loads $L_v$ (m)	Minimum Effective Barrier Height $H_e$ (mm)
3	250	80	1.1	80	5.5	600
4	250	80	1.1	80	5.5	800
5	500	170	2.4	355	12	1100
6	780	260	2.4	355	12	1400
SPECIAL	1000	330	2.5	380	15	1700 to 2000

The following load combinations shall be considered when using the loads in Table B3 for the design of the barrier:

- (i) Transverse and longitudinal loads acting simultaneously
- (ii) Vertical loads only.

Either the transverse or longitudinal load shall be considered as acting concurrently with the vertical load for the design of the deck slab and supporting structure, whichever is critical.

The effective height of a barrier is the height of the resultant of the lateral resistance forces of the individual components of the barrier. Barriers must have sufficient height to ensure that the minimum effective heights quoted above are achieved.

Actual heights of rigid concrete barriers may be marginally higher than the required effective height.

Barrier Performance Level 3 barriers shall have a minimum effective height ( $H_e$ ) of 600mm. However, for metal, concrete, or combined barriers with a vertical or near vertical face, the actual height ( $H$ ) shall not be less than 700mm.

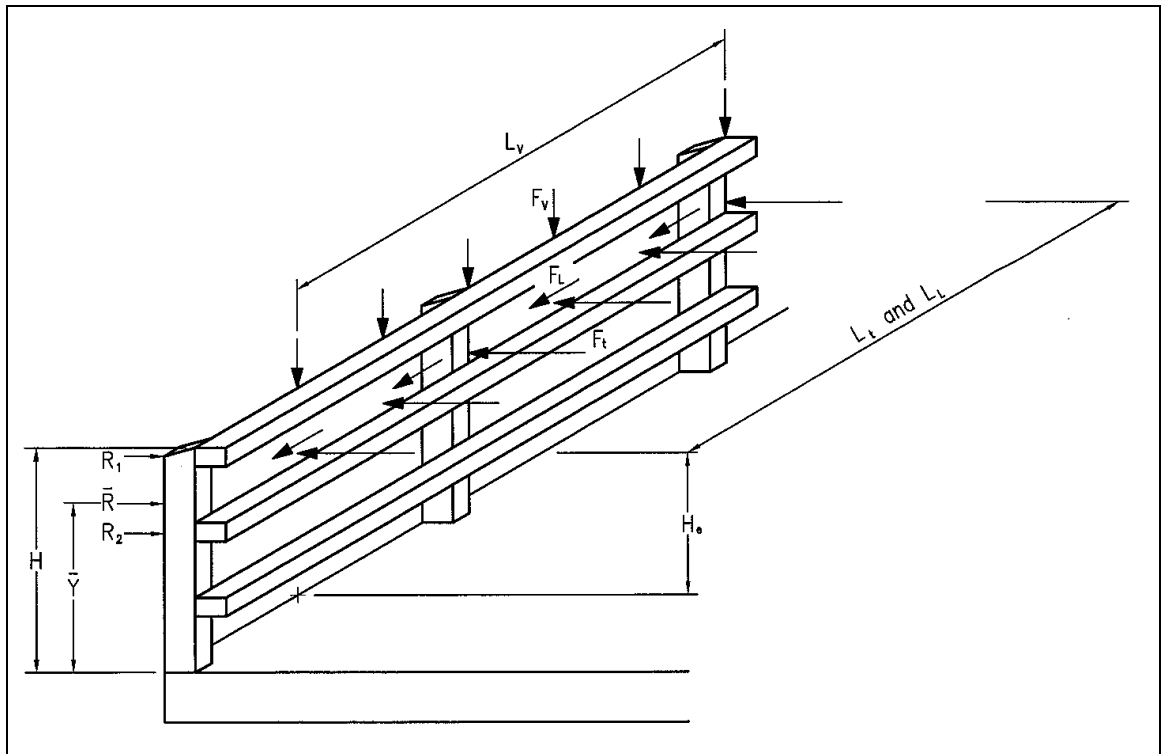

**Figure B10 – Barrier Design Forces**

‘H’ is the height of barrier from the level of the adjacent deck, footpath or verge to the top of the barrier.

### **B6.2 Design of Deck Slabs to Resist Barrier Forces**

Design of the deck slab shall ensure that failure is confined to the barrier and that the fixings to the deck, the deck slab and supporting structure are not damaged during failure of the barrier (except where holding down bolts are specifically designed to break away in Non-Rigid Barrier applications).

For rigid barrier systems, the equivalent ultimate limit state forces and contact lengths set out in Table B3 shall be used for the calculation of forces in the bridge deck for the required Performance Level. A load factor of 1.2 shall be applied to the loads in Table B3 for the design of the deck slab.

For flexible barrier systems, the deck slab shall be designed to withstand the forces mobilised by the yielding components of the barrier post (i.e. either the post fixings or post base acting in flexure or shear) developing their overstrength capacity. A load factor of 1.2 shall be applied to the overstrength force from the barrier post for the design of the deck slab.

**B6.3 Pedestrian and Cyclist Barrier**

In the following cases:

- on a footbridge
- on a footpath protected by a Non-Rigid Barrier or a Rigid Barrier

the Pedestrian Barrier shall be designed to resist horizontal and vertical service loads of 1.75 kN/m applied to the top rail. Other members shall resist a horizontal service load of 1.5 kN/m<sup>2</sup> applied to the gross area, and a point load of 0.5 kN in any direction at any point. Horizontal and vertical loads need not act concurrently. The load factor for pedestrian loads for the ultimate limit state shall be 1.7 for design of the barrier, fixings and supporting deck.

The minimum height to the top edge of the top rail shall be 1100 mm, or 1200 mm where a cycle path is present. Where the bridge is greater than 5 m above ground level and a cycle path is present, the minimum height to the top edge of the top rail shall be 1400 mm. Where a cycle path is present, the barrier shall present a smooth surface to cyclists, without snagging points.

**B6.4 Combination Pedestrian / Traffic Barrier**

In the following cases:

- On a Kerb with 500 mm wide strip,
- On a footpath with a kerb shaped as described in B2.5 (Combination Pedestrian/Traffic Barrier).

The Combined Pedestrian / Traffic Barrier shall be designed to resist the forces appropriate to the Barrier Performance Level required from B6.1.

Where the Vehicle Barrier portion of the Combined Barrier is lower in height than the requirements of B6.2, rails shall be added to accommodate pedestrian/cyclists as described in B2.3. The pedestrian/cyclist portions of the barrier shall resist loads of 4.4 kN/m horizontally and 1.75 kN/m vertically, applied to the top rail. Other members shall resist, as a minimum, the loads described in B6.2 above. The load factor for pedestrian/cyclist loads for the ultimate limit state shall be 1.7. Deflection of the barrier shall not allow the impact side wheels of the crash vehicle to have less than a 100 mm contact width with the bridge deck. The requirements of B2.3 (b) do not apply.

**B6.5 Kerb**

A Kerb shall resist, concurrently, a vertical HN wheel load with impact and a horizontal service load of 7.3 kN/m at a height of 200 mm, treated as Group 1A (refer to Section 3.4).

**B6.6 Deck Adjacent to Non-Rigid or Rigid Barrier**

The deck adjacent to a Non-Rigid or Rigid Barrier shall be designed for the loads specified in Section 3.1 of this manual.

**B7 Geometric Layout, End Treatment & Transitions - Transit New Zealand Requirements****B7.1 Rigid Barrier**

For crossfall up to 3% barriers shall be orientated vertically in the transverse direction. If the crossfall exceeds 3%, the barrier shall be rotated so that its axis is perpendicular to the road surface.

**B7.2 Non-Rigid Barrier Installation**

Installation of proprietary Non-Rigid Barrier systems shall be in accordance with the manufacturer's instructions for the Performance Level prescribed.

For Transit New Zealand standard highway and bridge guardrails, posts shall be erected normal to the road surface in the longitudinal direction, but vertical in the transverse direction for crossfalls or super elevations up to 3%. If the crossfall or super elevation exceeds 3%, the posts shall be rotated about a horizontal axis so that the barrier axis is perpendicular to the road surface.

Holding down bolts shall be specifically designed to be easily removed and replaced after failure or damage.

**B7.3 Bridge Approaches**

A transition barrier shall be provided to all bridge barriers. The length of approach transition shall not be less than 31.8m, unless justified by a detailed assessment of the length of need.

A smooth continuous tensile face shall be maintained along the transition. Any exposed rail ends, posts or sharp changes in barrier component geometry shall be avoided, or sloped outwards or downwards with a minimum splay of 1 in 10 for barrier components and 1 in 20 for kerb discontinuities.

The strength and stiffness of the barrier shall transition between any flexible roadside barrier and rigid, or semi-rigid bridge barrier to avoid vehicle pocketing at the interface.

Transition details given in AS/NZS 3845<sup>(1)</sup> Appendix F for rigid bridge barriers are acceptable up to NCHRP Report 350<sup>(2)</sup> Test Level 3 (Barrier Performance Level 3). Non-rigid wire rope barriers are not acceptable on bridge approaches.

The Performance Level selection for the transition barrier shall be based on a risk management approach as indicated by AS/NZS 3845<sup>(1)</sup>, but shall not be less than NCHRP 350<sup>(2)</sup> Test Level 3 where bridge side protection is present. The Barrier Selection method in B3 may be used to determine the appropriate Performance Level for the transition barrier. This should be applied to successive sections along the transition taking into account the risk factors present at each section.

Refer to Figure B12 for a typical approach layout for a Test Level 3 barrier using Bridge Guardrail.

**B7.4 End Treatment**

The approach end of a barrier shall have a crashworthy configuration, or be shielded by a crashworthy barrier or impact attenuation device.

Terminals shall comply with the evaluation criteria of NCHRP Report 350<sup>(2)</sup> Test Level 3 or greater, or be listed by the Federal Highway Administration (FHWA) of the US Department of Transport, for use on the National Highway System at Test Level 3 or higher.

Terminals detailed in Appendix F of AS/NZS 3845<sup>(1)</sup> are acceptable for Test Level 3 except those excluded by Transit Specification M/23.

**B7.5 Kerb**

Where the width between approach kerbs is different from that on the bridge, the transition between the two shall be an S-curve at a minimum radius of 260m on a single lane bridge and 800 m on a two-lane bridge.

**B8 Barrier Performance Level 3 Standard Designs - Transit New Zealand Requirements for Bridge Guardrail****B8.1 Bridge Guardrail**

In this section, Group 1A and 4 loadings are referred to. They are defined in Section 3.4.

The Transit New Zealand Bridge Guardrail is deemed to comply with NCHRP Report 350<sup>(2)</sup> Test Level 3 and is therefore approved for use in situations only requiring a Barrier Performance Level 3 barrier and where deflection can be accommodated. Design criteria for the Bridge Guardrail are as follows:

The post and rail system of a Bridge Guardrail shall be designed to redirect a 2 tonne passenger vehicle which strikes it at an angle of 25° and a speed of 100 km/h without serious injury to its occupants or interference with traffic in other lanes. Lateral deflection of the guardrail shall be limited to 600 mm. Damage to both vehicle and guardrail is expected, but the latter shall be readily repairable.

The minimum tensile strength of the rail and its splices shall be 450 kN.

The height of the top edge of the rail shall be 700 mm above the underlying road surface to within a tolerance of – 0 mm, + 20 mm.

In addition to the above performance requirements, each guardrail post shall resist the following transverse ultimate horizontal loads at a height of 550 mm (note: this is less than the dimension specified in Table B3 for Barrier Performance Level 3 barriers):

45 kN outwards  
19 kN inwards.

The design shall include specific provision:

- to enable post holding down bolts which fail to be easily removed and replaced.
- to allow for differential length changes between the bridge and the rail. Devices which use rubber components to absorb longitudinal movement shall not be used.

In addition, a top rail may be added where extra security is required for occasional pedestrians or for stock. A top rail shall be provided where the bridge deck is more than 10 m above ground or water level, or where the bridge crosses a road or railway. The top rail shall be at a height of 1100 mm to its top edge, and shall resist non-concurrent horizontal and vertical service loads of 1.75 kN/m at a load factor of 1.7.

The bridge deck shall be designed to resist the combination of the ultimate load reaction from the guardrail post together with an adjacent HN wheel load with impact. Group 4 load factors shall be applied to the dead load and the wheel load shall be treated as an overload.

### **B8.2 Guardrail Layout**

The geometric layout for the guardrail on the approach to single and two lane bridges is shown on Figure B12. Where the bridge guardrail is linked to highway guardrail, the bridge guardrail shall extend at least 28 m off the end of the bridge.

### **B8.3 Bridge Guardrail Performance**

The principle of operation of standard Transit New Zealand Bridge Guardrail is shown in Figure B11. The details of components are given in Figures B12 to B22. It should be noted that, in this design, the use of holding down bolts with a specific minimum and maximum strength is essential.

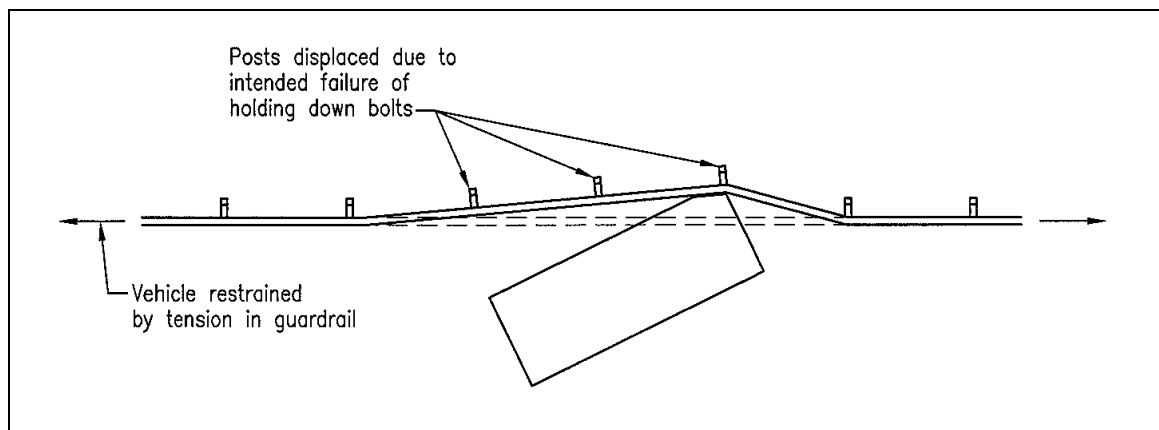

**Figure B11: Guardrail Displacement and Local Post Failure at Impact**

**B8.4 Bridge Guardrail Length Changes and Anchorage - Transit New Zealand Requirements****(a) Bridge Length Changes**

No free longitudinal movement shall take place in joints between lengths of guardrail.

The guardrail is assumed to be fixed in space between its end anchors, while the bridge deck (and the guardrail posts) move relative to the guardrail as a result of temperature, shrinkage, and creep effects. Provision shall be made in the guardrail at each post connection to enable relative movement to occur at this location. It is also assumed that longitudinal forces due to temperature changes can be resisted by the guardrail.

Guardrail expansion joints shall be used only on bridges where long lengths of continuous superstructure between deck expansion joints give length changes which cannot be accommodated within the normal post expansion provision. Where the distance from a guardrail anchor point to the nearest deck expansion joint, exceeds 100 m then an expansion joint is to be provided in the guardrail itself. The expansion joint shall enable slow movements to take place without restraint, but act as a rigid connection under impact loading. Expansion joints or other devices which use rubber components to absorb movement shall not be used.

Details of a suitable hydraulic joint are shown on Figures B21 and B22.

**(b) Guardrail Anchors**

Unless linked to highway guardrails on the approaches, a bridge guardrail shall be provided with end anchors capable of resisting its specified ultimate load. A bridge guardrail more than 150 m long shall be provided with intermediate anchors as described below, capable of resisting the same load. The following types of anchors shall be used in the situations described:

**(1) Buried Anchor**

Where the approach to a bridge is in soft rock or a soil cutting, the anchor to an approach guardrail should, if possible, be buried. Soil covering the anchor shall be well compacted. Details of a standard Transit New Zealand anchor are shown on Figure B19.

**(2) Anchor in a Rock Cutting**

Where the approach to a bridge is in rock cutting, the guardrail should, if possible, be anchored to rock. Details of a standard Transit New Zealand anchor are shown in Figure B19.

**(3) End Treatment**

Refer to Section B7.4.



(4) Intermediate Anchor on a Bridge

The anchor posts shall be designed to break away from the deck at their bases in the event of direct vehicle impact. When this occurs restraint of the guardrail ribbon is provided by the adjacent anchors.

Details of a standard Transit New Zealand anchor are shown on Figure B20.

**(c) Location of Anchors**

Guardrail anchor location requirements are as follows. They are shown diagrammatically in Figure B18.

- The maximum distance between adjacent anchors shall be 150 m.
- The maximum length over three consecutive anchors shall be 200 m.
- Intermediate anchors shall be located at neutral points. Neutral points are defined as points on the bridge length which do not move longitudinally with length changes. If this is not possible, due to location of two or more anchors between consecutive expansion joints, the effect of the movement of the anchors relative to the guardrail due to creep and shrinkage shall be taken into account in the design by providing for adjustments in the anchor cable connections.
- If there is a high proportion of very heavy traffic and/or severe curvature, consideration should be given to providing guardrail anchors at every neutral point.
- End anchors shall be located at least 32 m from the bridge abutment.
- The location of buried anchors or anchors in rock cuttings will depend on the local terrain and geology.

**B9 References**

- (1) AS/NZS 3845; 1999, *Road Barrier Safety Systems*, Standards Australia and Standards New Zealand jointly.
- (2) NCHRP, 1993, *Recommended Procedures for the Safety Performance Evaluation of Highway Features*, National Cooperative Highway Research Program Report No. 350, National Academy Press, Washington DC.
- (3) Austroads, 1999, *Australian Bridge Design Code (Draft) 16/11/99*, Part 1 – General, Austroads Inc, Sydney.
- (4) AASHTO, 1989, *Guide Specification for Bridge Railings*, American Association of State Highway and Transportation Officials, Washington DC.
- (5) \_\_\_\_\_, 1997, *Project Evaluation Manual*, Manual No. PFM2, Transfund New Zealand, Wellington.
- (6) \_\_\_\_\_, 1997, *Project Evaluation Manual*, Manual No. PFM2, Transfund New Zealand, Wellington.

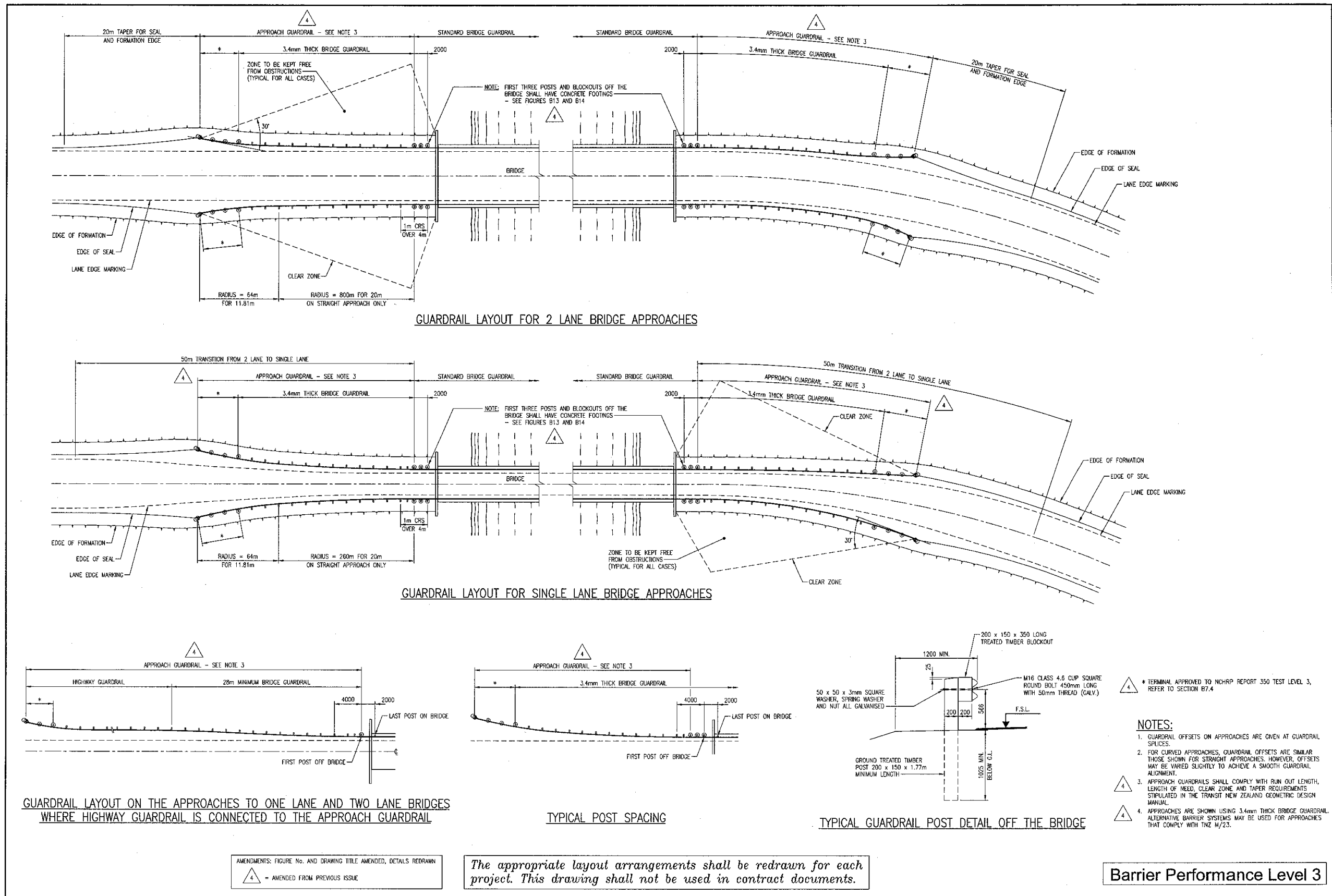
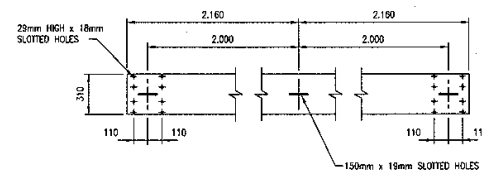
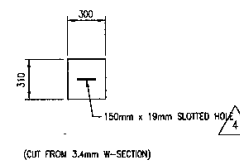

Figure B12: Transit New Zealand Bridge Guardrail Approach Layout



3.4mm W-SECTION GUARDRAIL  
TYPE 1



(CUT FROM 3.4mm W-SECTION)  
BACKING PIECE

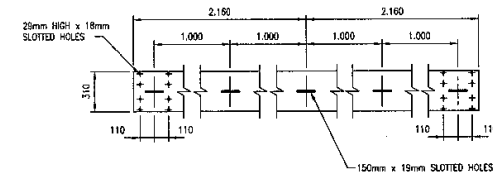

SPECIAL 3.4mm GUARDRAIL END PANEL AT ABUTMENT  
TYPE 4

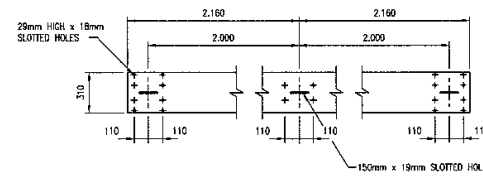

MODIFIED 3.4mm W-SECTION GUARDRAIL  
TYPE 2

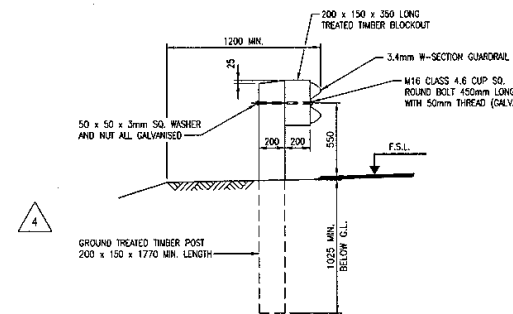

TYPICAL GUARDRAIL POST DETAIL  
OFF THE BRIDGE

NOTES

1. ALL STEELWORK TO BE HOT DIP GALVANISED AFTER FABRICATION TO AS/NZS 4680 AND STRAIGHTENED AFTER GALVANISING IF REQUIRED.
2. GUARDRAIL PANELS, BACKING PIECES AND SPLICE BOLTS TO BE IN ACCORDANCE WITH TNZ M17/P FOR BRIDGE GUARDRAIL.
3. GUARDRAIL POSTS SHALL BE PLACED VERTICALLY IN THE TRANSVERSE BRIDGE DIRECTION AND NORMAL TO THE GRADE IN THE LONGITUDINAL BRIDGE DIRECTION OR AS INDICATED ON GUARDRAIL LAYOUT.

AMENDMENTS: FIGURE No. AND DRAWING TITLE AMENDED, DETAILS REDRAWN, TYPE 3 DETAIL REMOVED  
△ = AMENDED FROM PREVIOUS ISSUE

*The appropriate layout arrangements shall be redrawn for each project. This drawing shall not be used in contract documents.*

Barrier Performance Level 3

Figure B13: Transit New Zealand Bridge Guardrail Post Details on Bridge Approach

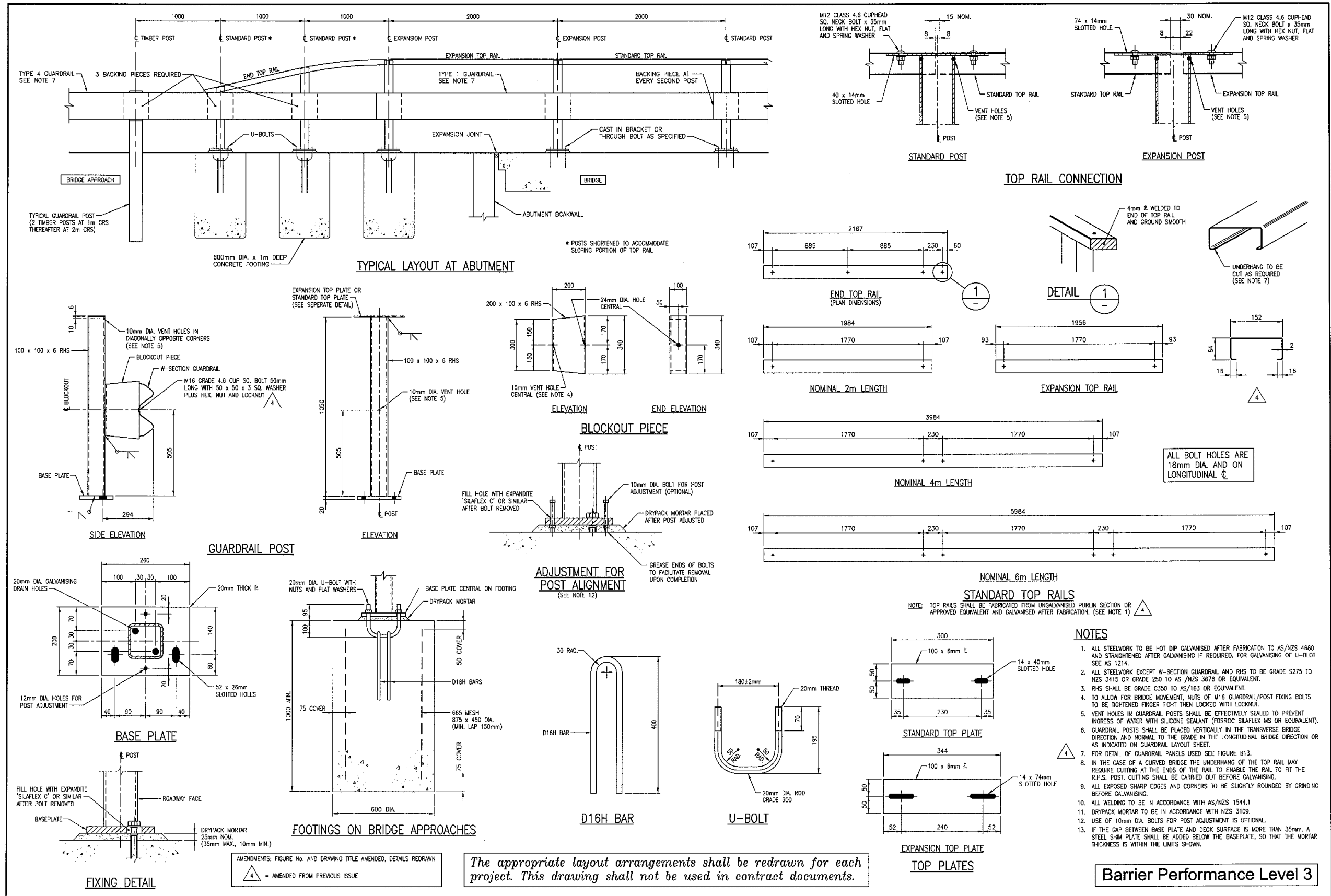

Figure B14: Transit New Zealand Bridge Guardrail Assembly and Fixing Details on Bridge and Approach

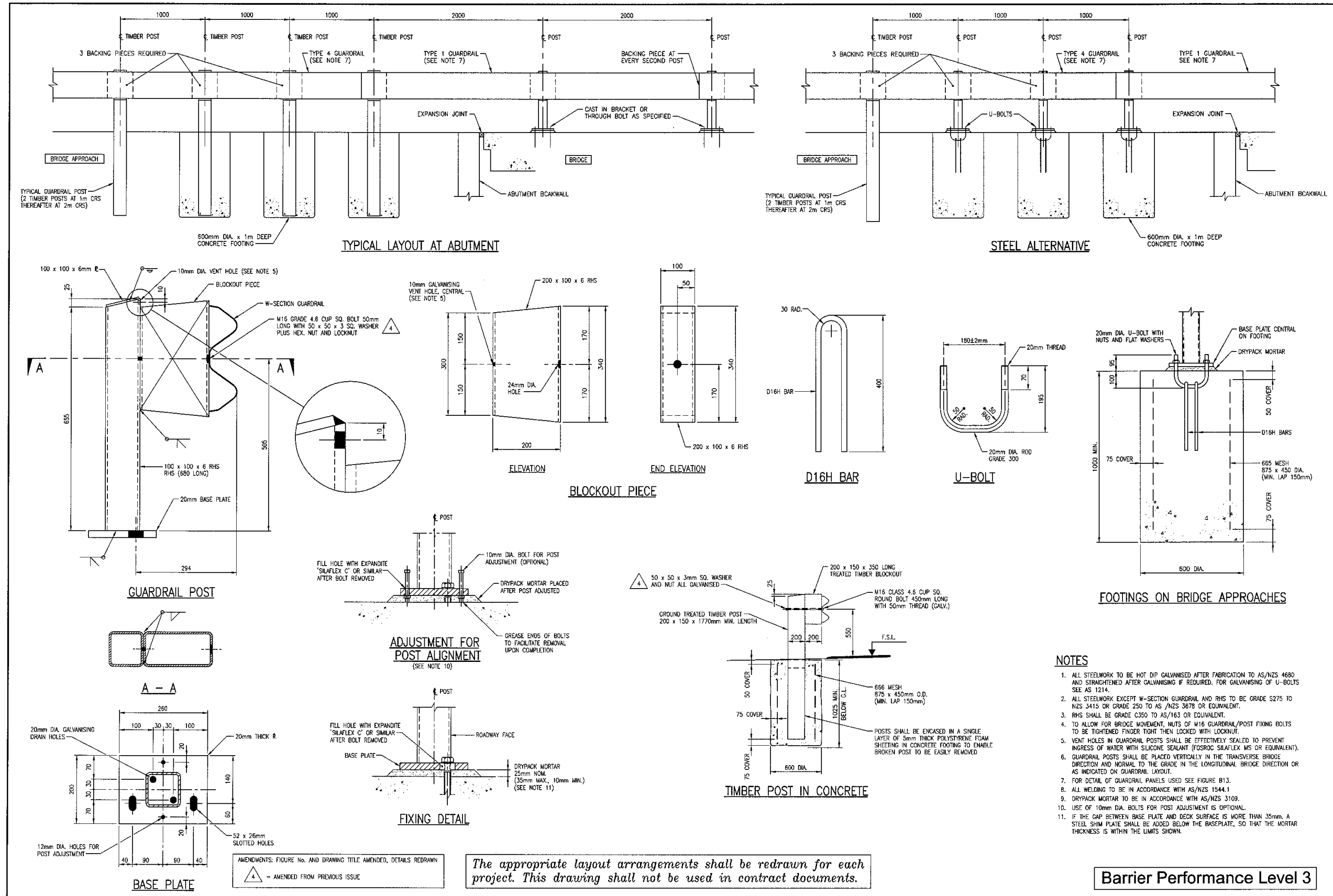

Figure B15: Transit New Zealand Bridge Guardrail Guardrail Assembly and Fixing Details on Bridge and Approach

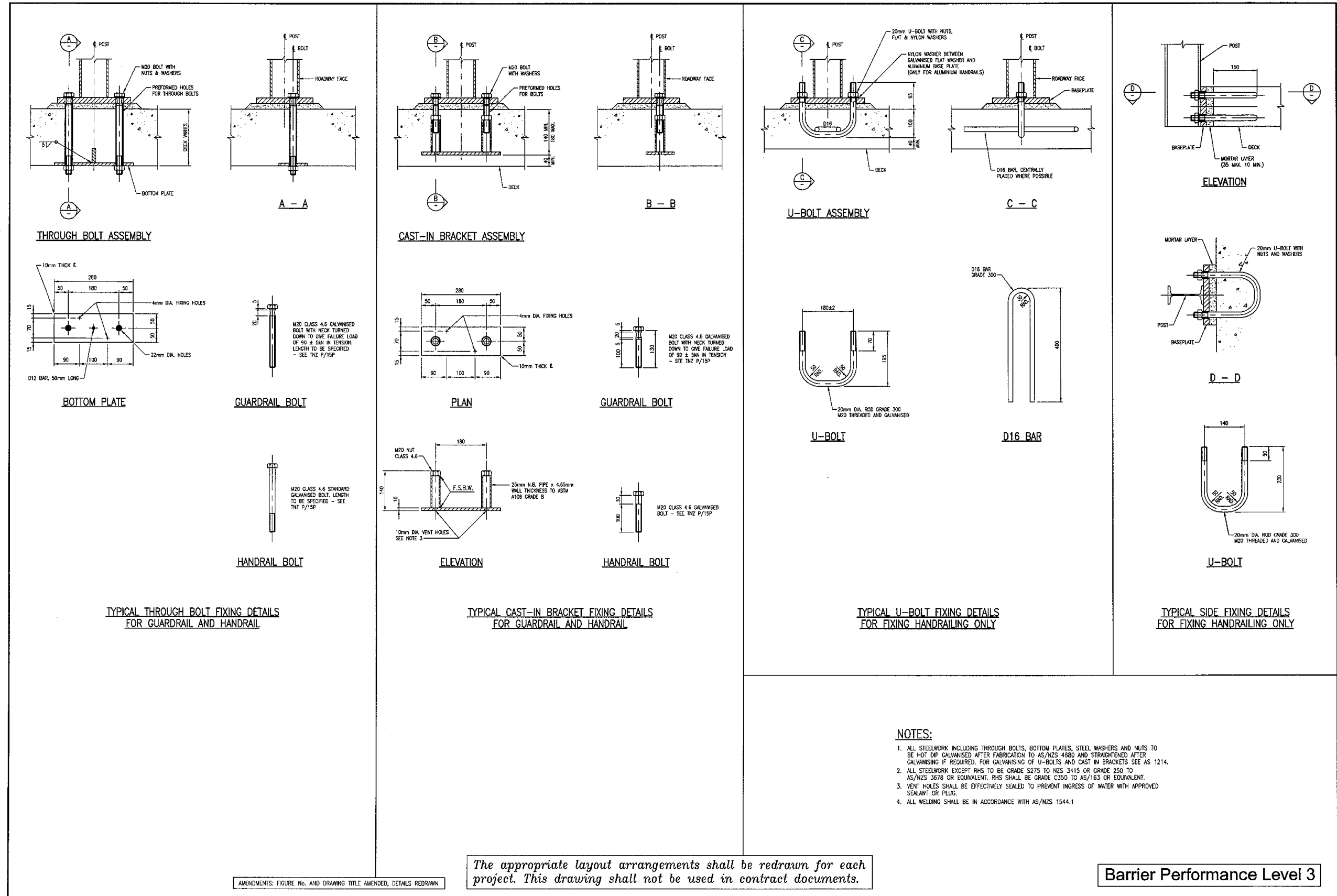
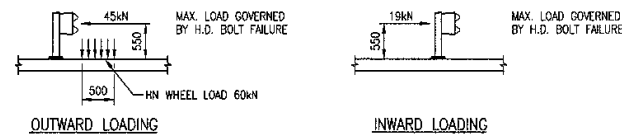

Figure B16: Transit New Zealand Bridge Guardrail Holding Down Details

**CRITERIA FOR DESIGN OF DECK FOR GUARDRAIL LOADING**

1. GUARDRAIL POST LOADS ARE GOVERNED BY HOLDING DOWN BOLT CAPACITY (SEE INZ P/15P)
2. USE CAPACITY DESIGN PRINCIPLES, WITH 'DECK PROTECTION FACTOR' OF 1.2 FOR GUARDRAIL MOMENT, AT DEPENDABLE STRENGTH OF DECK ( $\phi = 0.9$ ).
3. ASSUMING W/V WHEEL LOAD ACTS CONCURRENTLY AND USE GROUP AND LOAD FACTOR, WITHOUT IMPACT (OUTWARD LOADING ONLY).
4. ASSUME MOMENT IS RESISTED BY A STRIP OF DECK 1m WIDE.



**CRITERIA FOR DESIGN OF DECK FOR HANDRAIL LOADING**

1. USE CAPACITY DESIGN PRINCIPLES, WITH A LOAD FACTOR OF 1.7 APPLIED TO LIVE LOADS SHOWN AT DEPENDABLE STRENGTH OF DECK ( $\phi = 0.9$ ).
2. ASSUME OTHER LOADS DO NOT ACT CONCURRENTLY.
3. ASSUME MOMENT IS RESISTED BY A STRIP OF DECK 1m WIDE.

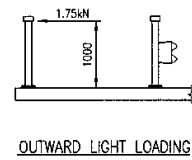

**GUARDRAIL ANCHORED TO SOLID REINFORCED CONCRETE SLAB DECK**

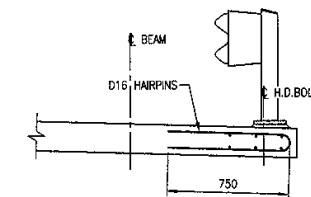
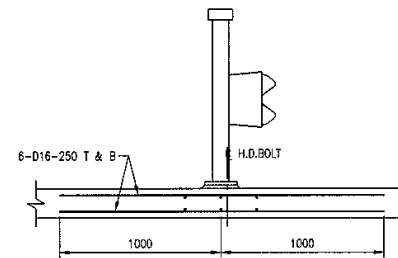
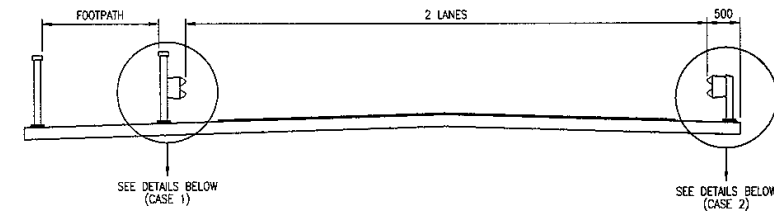

**GUARDRAIL ANCHORAGE TO DOUBLE CORE BEAM UNITS**

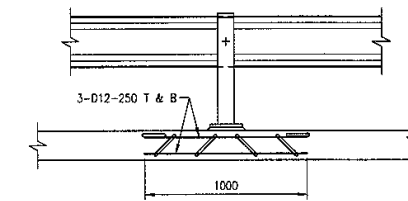
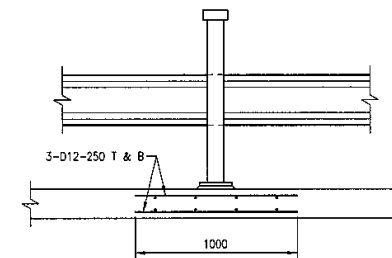
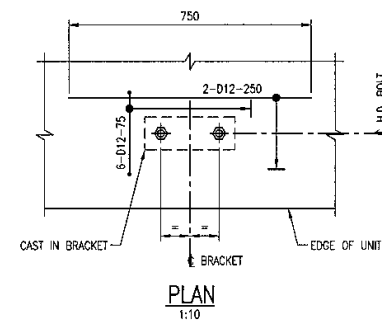
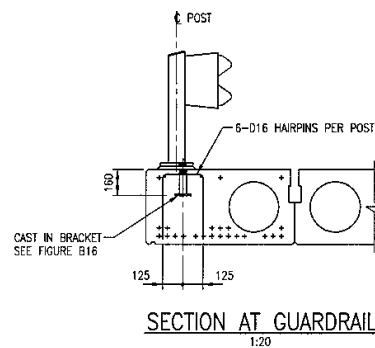

**NOTES:**

1. REINFORCEMENT SHOWN HERE IS IN ADDITION TO NORMAL STEEL PROVIDED FOR TRAFFIC LOADS.
2. THIS STEEL ARRANGEMENT APPLIES TO ALL DECK THICKNESSES 120mm & ABOVE AND FOR ALL TYPES OF STANDARD BEAM SUPPORT SYSTEMS, EXCEPT DOUBLE CORE UNITS - SEE BELOW.
3. ALL REINFORCEMENT SHOWN SHALL BE GRADE 300 AND BE DEFORMED.

CASE 1 : GUARDRAIL BETWEEN BEAMS

CASE 2 : GUARDRAIL ON DECK CANTILEVER

AMENDMENTS: FIGURE No. AND DRAWING TITLE AMENDED

*The appropriate layout arrangements shall be redrawn for each project. This drawing shall not be used in contract documents.*

**Barrier Performance Level 3**

**Figure B17: Transit New Zealand Bridge Guardrail Deck Slab - Details Near Guardrail Posts**

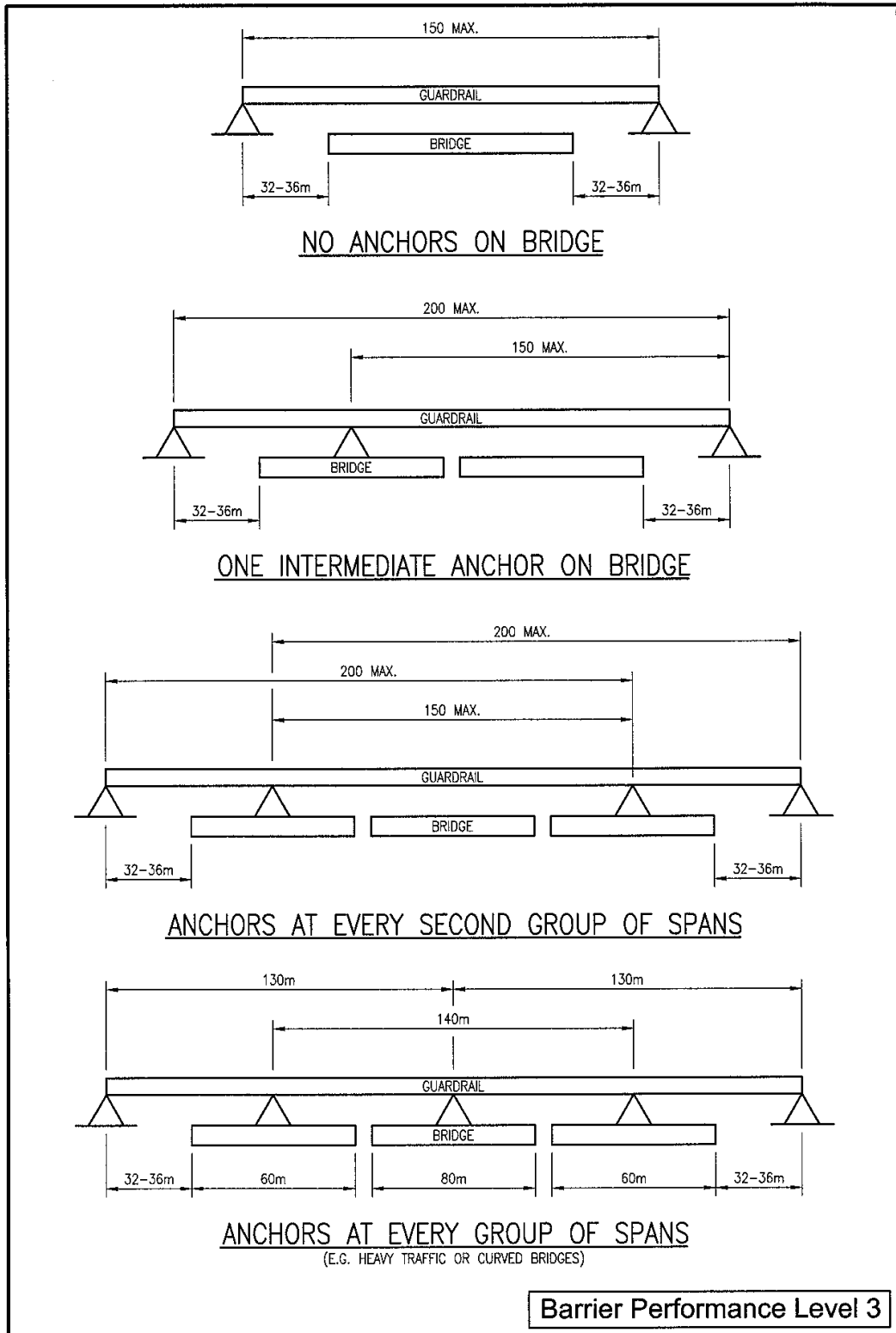

**Figure B18: Transit New Zealand Bridge Guardrail Anchor Locations**



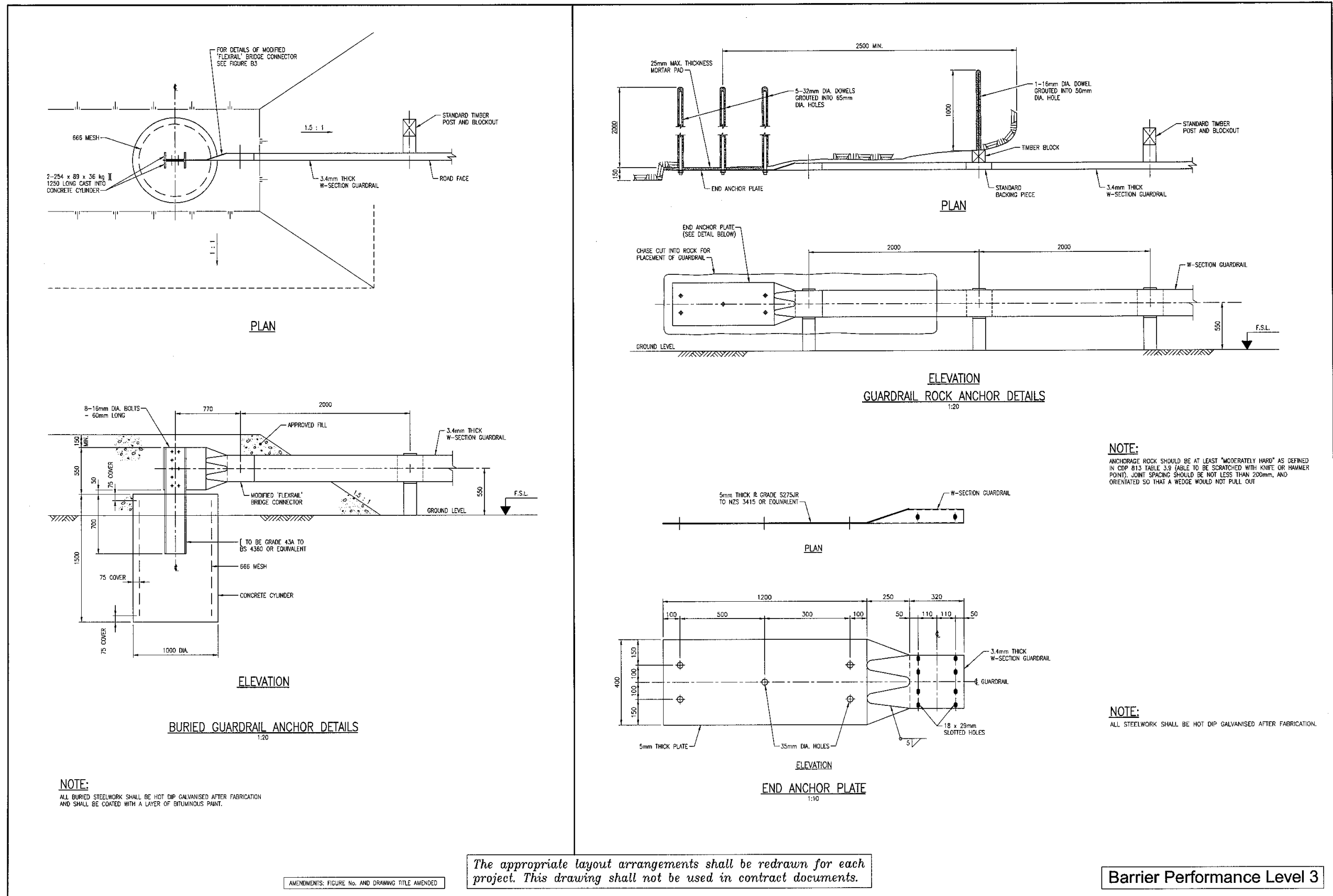

Figure B19: Transit New Zealand Bridge Guardrail Buried Anchor and Rock Anchor Details

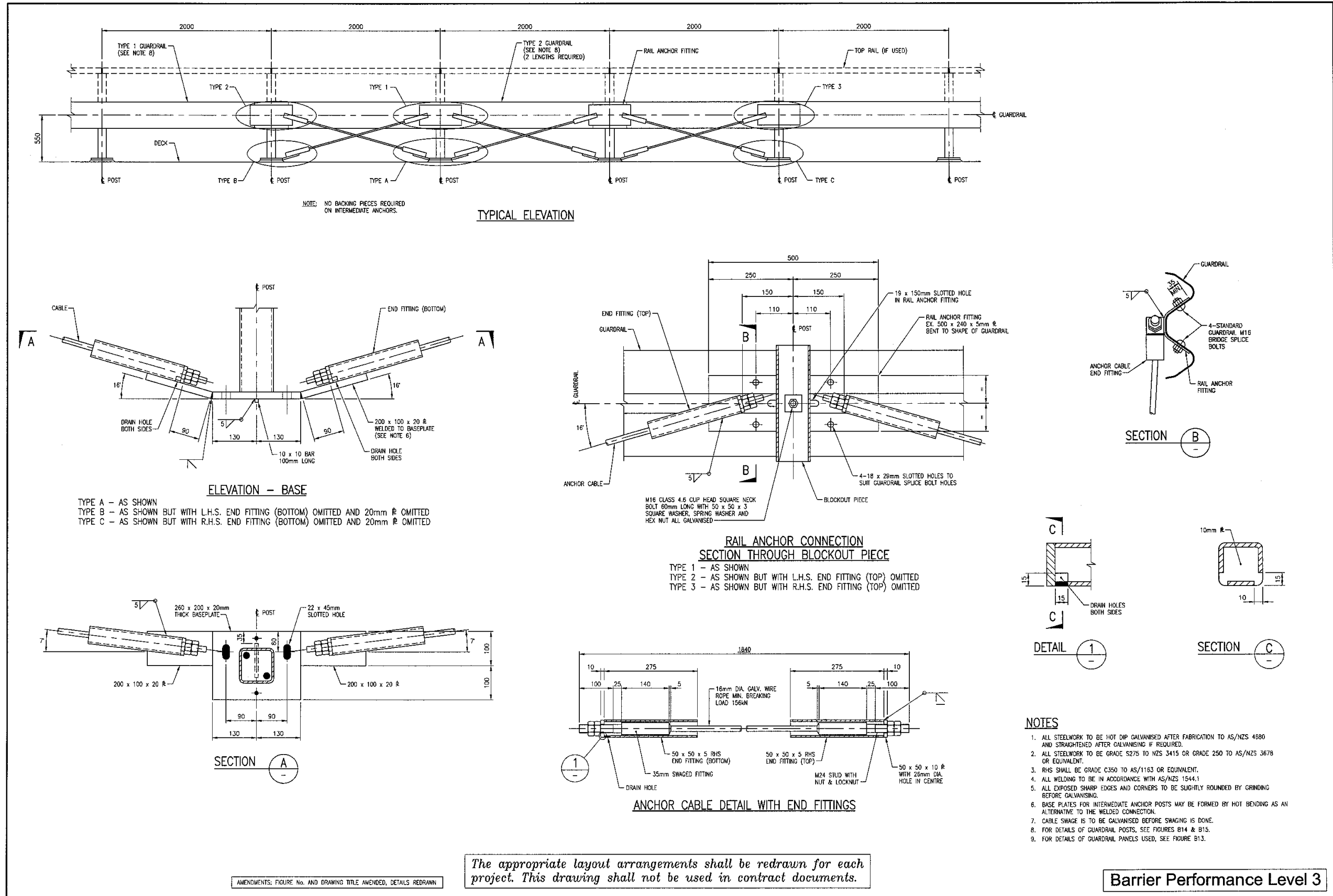

Figure B20: Transit New Zealand Bridge Guardrail Intermediate Anchor

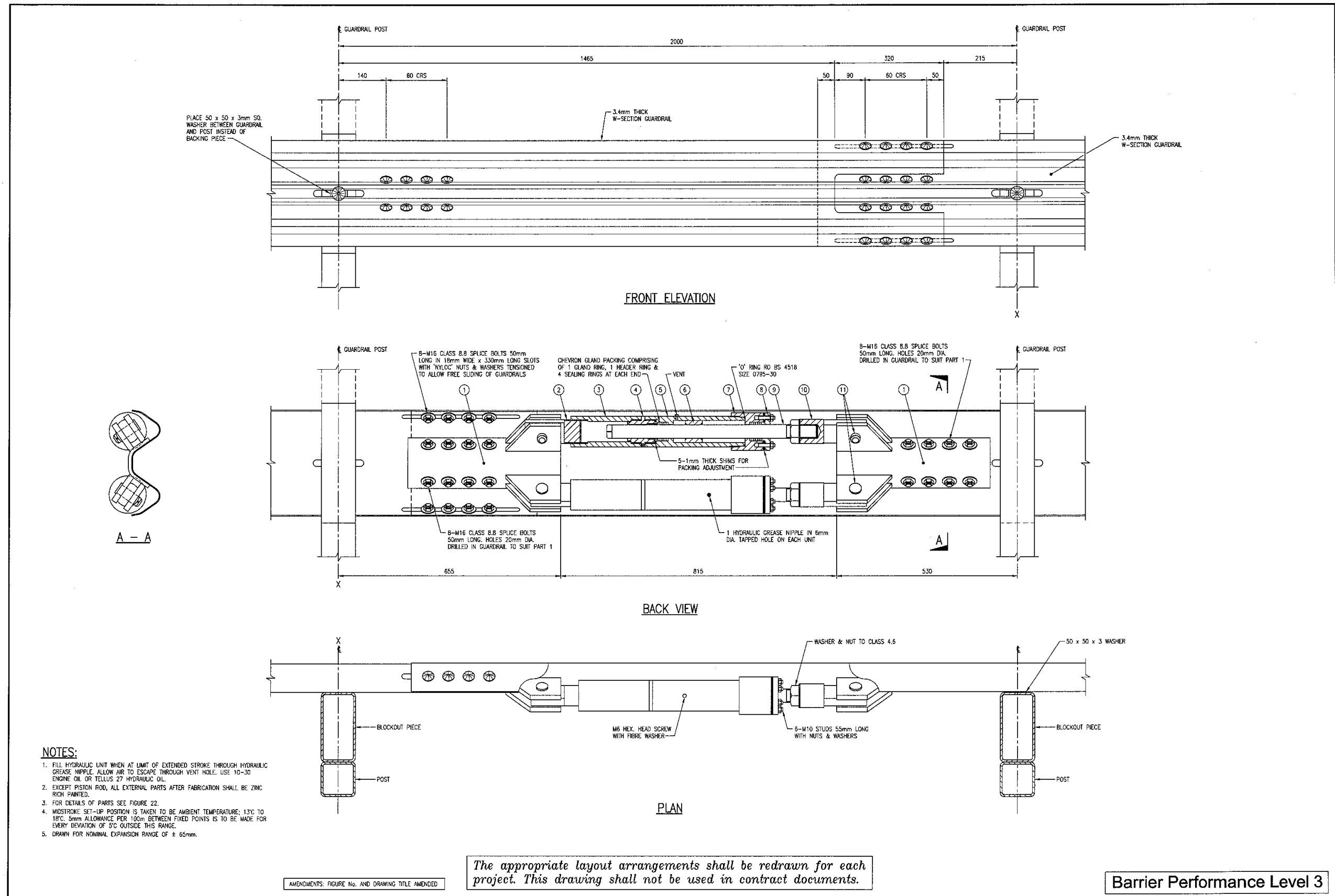

Figure B21: Transit New Zealand Bridge Guardrail Hydraulic Expansion Joint - Layout

