



SH20 Manukau Extension

FINAL LANDSCAPE & URBAN DESIGN MASTERPLAN

PREPARED FOR LEIGHTON WORKS

BY JASMAX

JUNE 2007

V1233-DP-L-000-RevA-Final L & UD Masterplan



NZ TRANSPORT AGENCY
WAKA KOTAHI

Jasmax



Leighton Works

SH20 Manukau Motorway Extension

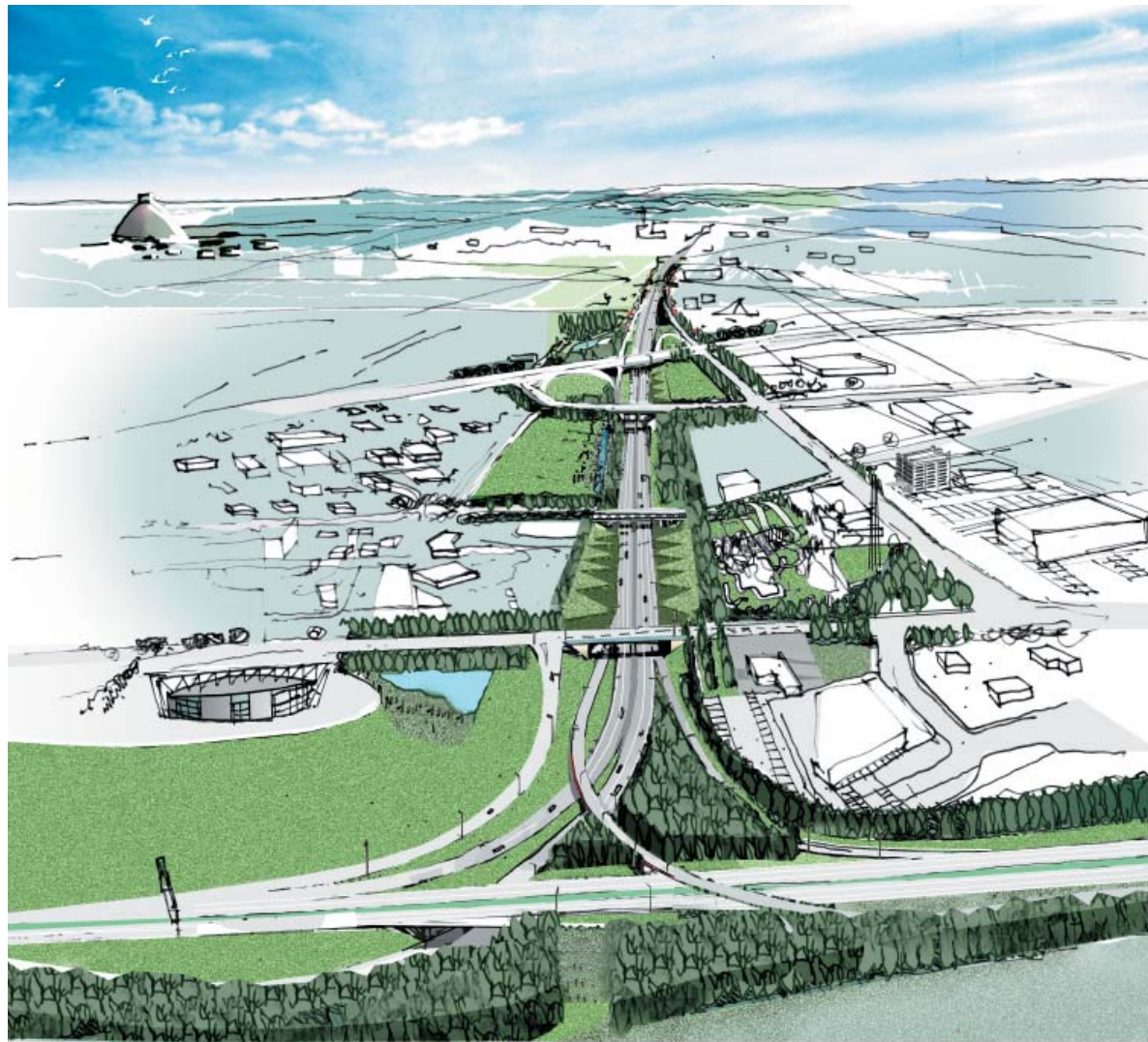

SH20 Manukau Extension

FINAL LANDSCAPE & URBAN DESIGN MASTERPLAN

PREPARED FOR LEIGHTON WORKS
BY JASMAX

JUNE 2007

V1233-DP-L-000-REVA-FINAL L & UD MASTERPLAN



NZ TRANSPORT AGENCY
WAKA KOTAHI



Contents

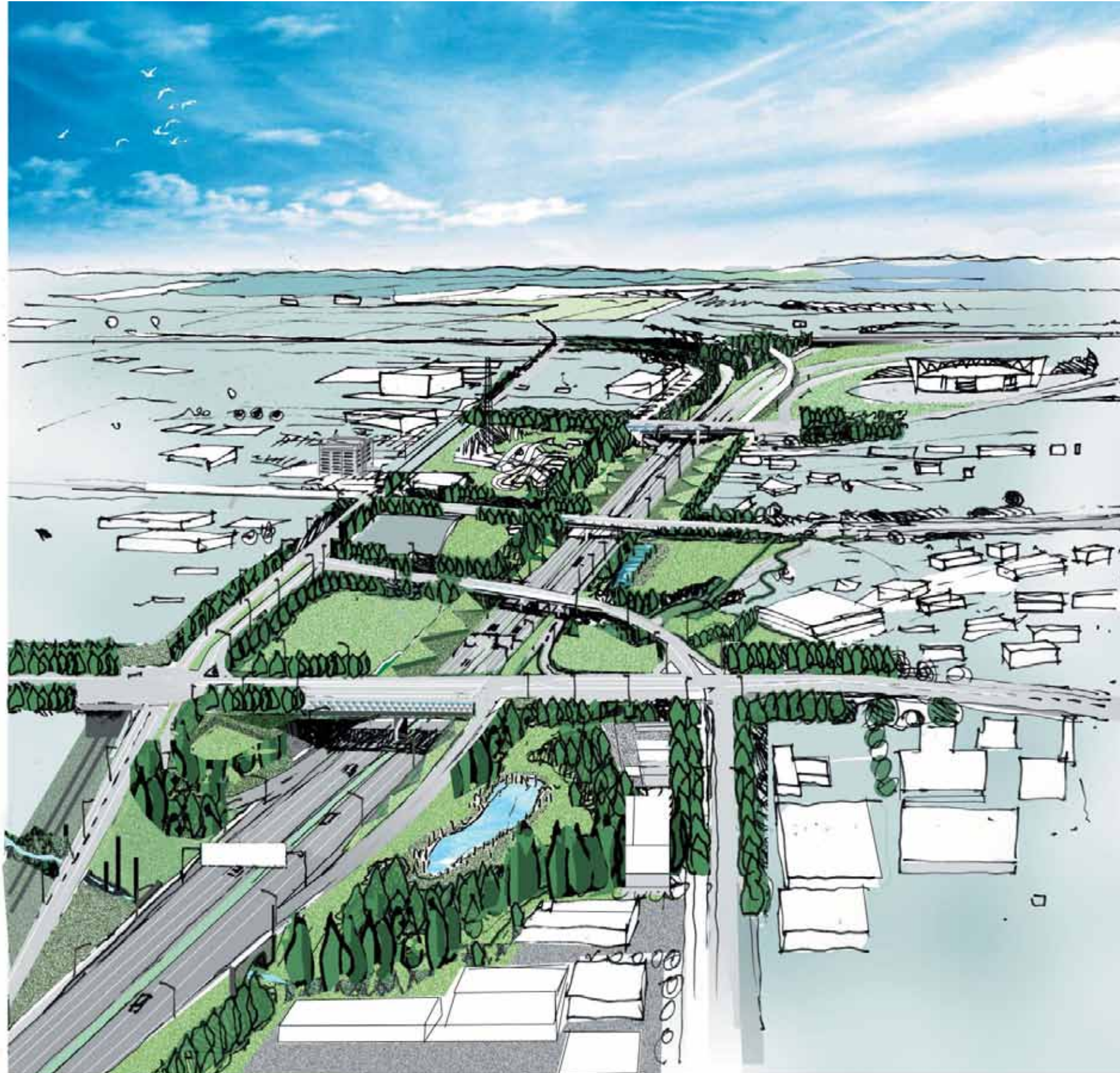

- 01 Summary
- 02 Introduction
- 03 Aims and Objectives of the Masterplan
- 04 Context/Analysis
- 05 Design Cues/Triggers
- 06 Integration of the Motorway into Manukau City
- 07 Integration of Art into the Motorway Environment
- 08 Structures-Bridges + Retaining Walls
- 09 Softscape Elements
- 10 Landscape and Urban Design Masterplan
- 11 Cross Sections
- 12 Figure List

01 Summary

1.0 Summary of the Leighton Works Proposal

The Outline Landscape & Urban Design Masterplan proposes site specific treatments to infrastructure and landscape components to signify this area as the “Gateway” to Manukau City and contribute to the series of gateway elements that punctuate the journey along SH1 into Auckland. Concepts for these solutions are driven by references to the cultural make up and natural history of Manukau, including its volcanic origins. References are made to historic vegetation patterns, of the site, and to charismatic remnants of vegetation seen in and around the Auckland region.

This report is the 3rd edition. It has been reviewed and amended in response to comments from Transit NZ peer reviewers following acceptance of the Tender bid . Many of the comments are concerned with Detailed Design and will be addressed through ongoing coordination with the Leighton Works design team and Manukau City Council.

This report is conceptual only. Designs will be developed through an interactive process throughout the detailed design phase and are therefore subject to change.

Below is a summary of the comments and responses:

- Locations of plantings relative to driver sight lines, cctv view cones, carriageways and safety clear zones will be addressed as the Detailed Design package is developed
- Access to grassed areas, stormwater ponds and other areas requiring maintenance will be addressed as the Detailed Design package is developed
- Locations of plantings shown in Concept Plans that overlap fenced areas, access points to private lots and signage gantries will be addressed as the Detailed Design package is developed
- The ARC Guidelines for Riparian Planting will be referred to as the Detailed Design package proceeds
- Barriers on bridges that do not comply with cycle safety standards and the Building Code will be addressed as the Detailed Design package is developed
- Stormwater ponds and access routes not shown in the previous version dated Dec 2006 will be incorporated into the Detailed Design package as they are developed by the Engineers
- Roading alignments not shown in the previous version dated 2006 will be incorporated into the Detailed Design package
- Access along the Puhinui Walkway and its interface with works within the SH20 Manukau Extension designation boundary will be resolved through consultation with Manukau City Council to ensure a seamless interface, including safety issues associated with the twin culverts
- Street tree planting locations and specified sizes will be adjusted in the Detailed Design package and through consultation with Manukau City Council
- We confirm that the geometric planting patterns proposed in the civic area will be effective when viewed from oblique angles
- Plantings around ponds will be such that they discourage wading birds from flying low across the motorway
- The barriers on the Redoubt Flyover will continue to be developed in coordination with the Engineers to ensure compliance and reduce maintenance issues
- Median barriers and associated plantings will be resolved in the Detailed Design package
- All surfaces that require graffiti guard will be treated as required by TNZ, including noise walls
- We confirm that the yellow coloured bridge components have been downgraded to non-coloured. The out-dated aerial sketch will be updated
- Consultation with the community as discussed in Section 7.1 will be through Manukau City Council rather than an exhaustive process with community representatives as could be construed from the previous wording
- “Enrichment planting” means plantings that are added to the standard native highway planting mix to add diversity and legacy along the length of the alignment. Until otherwise confirmed, this may, in some cases, require 2 stage plantings to maximise chances of successful establishment
- Bark mulching will be adopted in place of weed mat. On slopes of around 3:1 this is acceptable
- We will not show detailed cross sections of noise walls in the concept Masterplan. This will be developed in the Detailed Design package

1.1 Summary of Landscape and Urban Design Concepts and Solutions

- The motorway alignment is integrated into the Manukau City urban fabric through the integration of site-specific character theming elements, improvement of physical connections and the pedestrian environment, the continuity of landscape treatments and land uses over the motorway, and the improvement of visual connections to off-site landmarks;
- The arts programme, which is driven by site specific design solutions for the motorway, its components and landscape context is integrated into the infrastructure, landform and plantings rather than as stand-alone artefacts;
- References to the cultural make-up of the city are realised through the adoption of a repeating Pacifica patterning theme via a variety of embellishments including geometric earthwork and planting patterns and detailed concrete formwork and bridge railings. Consultation with community appointed representatives and MCC will be undertaken to ensure acceptance and advocacy by the community;
- References to the underlying volcanic geology of the site are realised through the rustication of retaining walls and spill-through abutments below current ground level;

- The planting strategy will improve the urban ecology including habitat targeted plantings for forested areas, waterways and wetlands. Plantings will screen and filter views into undesirable industrial areas and frame and protect views to key landmarks and rural and urban panorama's;
- Plantings will integrate with the Manukau City Tree Policy for street trees and open spaces, including Hayman Park and will comply with the TNZ Guidelines for Highway Landscaping;
- Safety considerations for pedestrians and cyclists on the roadway network and adjacent Puhinui Stream Walkway will take guidance from the MCC publication 'Design Out Crime – Crime Prevention through Environmental Design Dealing with Public Realm Hotspots';
- Lighting will highlight site features and surfaces to provide a stimulating and safe urban environment;
- Noise walls, where required, will be integrated into the motorway and urban environment to support the proposed character and context of the motorway alignment; and

- Urban and landscape design solutions will provide a safe and legible journey and a memorable road experience for users and to use this major infrastructure project as a catalyst for regeneration, renewal and the revitalisation of Manukau City centre.

1.2 Summary of Contents

This report provides a graphic and technical summary of the following:

- Principal's Requirements;
- Analysis of the site area, its context and adjacent land use constraints and opportunities;
- Landscape and urban design approach to best integrate the motorway alignment into the physical and cultural environment;
- Landscape and urban design concepts and solutions; and
- Architectural solutions for bridges, structures and hardscape elements.

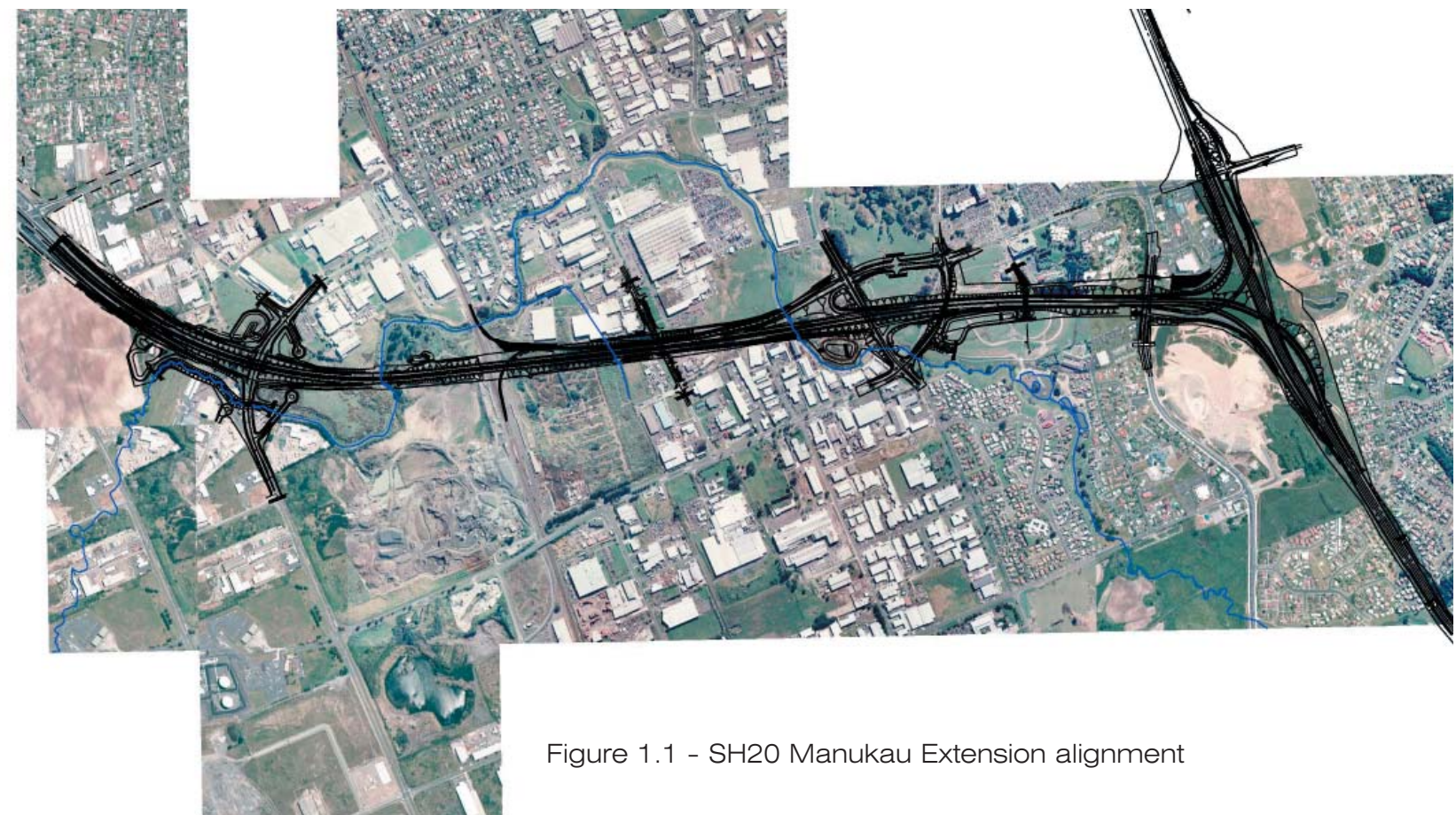

Figure 1.1 - SH20 Manukau Extension alignment

02 Introduction



Figure 2.1 - Tapa Cloth

2.0 Requirements of the Principal

The Principal's vision for the SH20 Manukau Extension is "to create a corridor that enhances the urban fabric of Manukau City and acts as a gateway to the Manukau City centre". It must be visually stimulating, attractive, and express a localised 'sense of place' unique to this vitally important part of the Auckland Region without compromising core safety and efficiency requirements. To achieve this vision the key objectives are to:

- (i) Utilise Manukau City's distinctive cultural, visual and spatial character to design elegant landscaped areas and built elements;
- (ii) Provide the driver with a coherent set of images based upon an underlying theme, but also respond to differing contexts along the route;
- (iii) Think 'beyond the pavement' to consider effects on neighbouring land uses and the experience of people using over-bridges or underpasses, and
- (iv) Encourage 'environmentally responsive design solutions'.

This report has been prepared with reference to the "Draft Landscape and Urban Design Management Plans" and the Draft Project Environmental Management Plan (PEMP).

2.1 Requirements of the Outline Landscape and Urban Design Masterplan

It is a requirement that the Masterplan shall reflect the landscape and urban design philosophy above and include the following:

- (i) Illustrative landscape and urban design report;
- (ii) Overall concept plan at 1:1000 scale;

- (iii) A series of typical plans, illustrations and perspectives illustrating urban design integration proposed;
- (iv) Schedule of planting themes;
- (v) Outline details of bridges and structures proposals by architectural consultant;
- (vi) Perspectives or visual simulations of the road illustrating intended character
- (vii) A report detailing the opportunities for introducing artwork or other visually stimulating aspects into the design; and
- (viii) 10 x cross sections.

2.2 Purpose of this Masterplan

The purpose of this 2nd Edition Masterplan is to integrate the design and documentation prepared by the Leighton Works urban design team into a single Outline Urban Design and Landscape Masterplan and to respond to comments from TNZ following acceptance of the Leighton Works tender.

This report will be submitted for consideration during the Conceptual Documentation Phase to form the basis for a final integrated Landscape and Urban Design Masterplan which will be prepared for approval by the Principal prior to submission to Manukau City Council.

03 Aims and Objectives of the Masterplan

3.0 Landscape and Urban Design Requirements

Based on the Principal's Requirements, landscape and urban design solutions will involve the following:

- General - All observable elements will offer a high degree of visual amenity from all viewpoints, including such forms as bridges or retaining walls;
- All designed elements should be coordinated to form a coherent set of images responding to the Urban Design and Landscape Management Plans;
- Bridges - Bridges are to be designed in accordance with the Urban Design Management Plan with strong sculptural form integrating decorative elements where appropriate with the integration of secondary elements such as ducting, planting, lighting, railings and signage. These elements should not detract from views and must be readily maintainable;
- Retaining Walls, noise walls, and abutments are to be designed to integrate with other built elements and/or the natural topography;
- Local materials will be used in the finishes where possible;
- Artwork in the form of carved relief on open surfaces and other features that are part of a coherent set of themes;
- Include spill-over planting and/or terraced walls (to improve visual amenity and reduce noise/heat reflection) if they are appropriate design measures;
- Safety Barriers - are to be designed to take cognisance of the draft Urban Design Management Plan;
- Gantries, Support Structures and Poles - are to be designed to take cognisance of the draft Urban Design Management Plan;

- Embankments and Cuttings - should be graded to relate to the natural surrounding topography;
- Landscape - Landscape planting themes should be designed to strengthen the 'sense of place' aspect of the project as shown in the draft Landscape Management Plan; and

- Planting should be designed to enhance existing views and vistas, reduce maintenance, to help establish landmarks or way-finding elements at key locations such as exits and to reduce the likelihood of weed infestation.

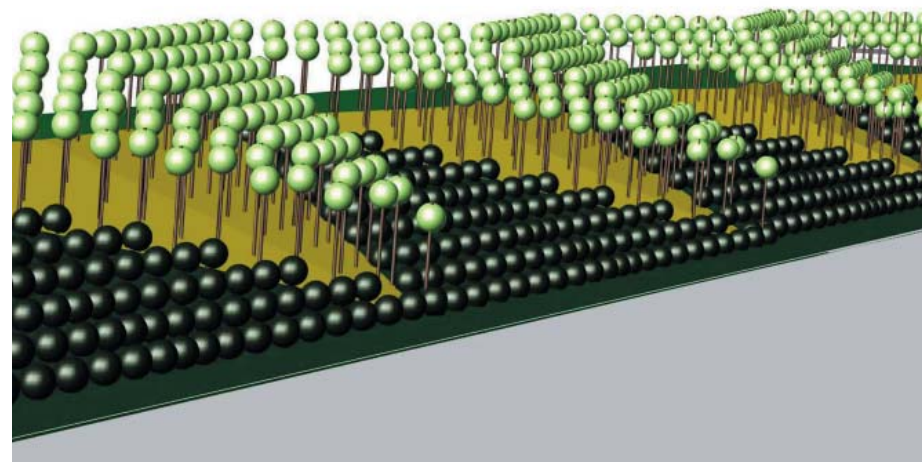

Figure 3.1 -3D model of Pacifica Fractals planting.

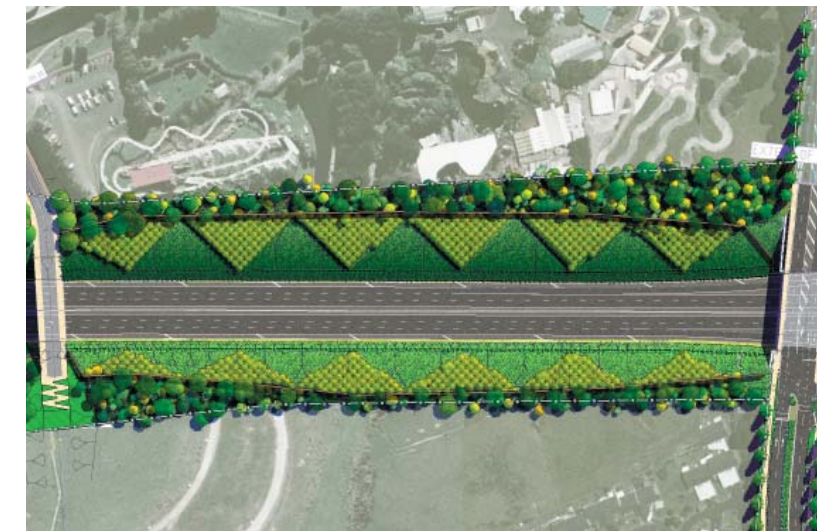

Figure 3.2 - Pacifica Fractals



Figure 3.3 - Example of Riparian Planting.



Figure 3.4 - Riparian Area

3.1 Aims and Objectives of the Leighton Works Team

Beyond the previously stated TNZ project objectives, there are a number of more specific key aims and objectives raised by this team for the landscape and urban design team of the SH20 Manukau Extension including:

- To use the motorway as a catalyst for urban regeneration, renewal, and increased connectivity and permeability between the various precincts which have been identified along the route;
- To use the motorway to help celebrate and identify the City of Manukau;
- To develop an arts approach that is integrated into the landscape and structures as a contextual overlay rather than adopting stand alone artefacts;
- To celebrate and highlight the multicultural character and identity of the City of Manukau with its Pacifica community;
- To highlight and celebrate the underlying geology and natural forces which have shaped the regions' diverse landscapes especially the volcanic cones and lava fields;
- To develop a memorable "gateway" experience for travellers arriving and departing Manukau with unique landscape treatments and structural elements;
- To capture and frame important views of key landmarks, landscape features and urban and rural panoramas from the motorway;
- To protect and enhance the recreational, amenity and cultural values of the Puhinui Stream corridor; and
- To develop a palette of materials and methods of construction which is economically achievable, physically robust, readily maintained and has long term viability.



Figure 3.5 - Example of Riparian Planting.



Figure 3.6 - Storm water pond and Puhinui Stream



Figure 3.7 - Pohutukawa close up.



Figure 3.8 - Pohutukawa Planting

3.2 Urban Design Principles

This report is intended to draw together the urban design and landscape elements of the proposed SH20 Manukau Extension to meet the objectives of the TNZ Urban Design Management Plan and the MfE Urban Design Protocol, of which TNZ are a signatory. The urban design principles for this project are drawn from the 7 C's that are an integral part of the MfE Urban Design Protocol:

Context

- Urban design and landscape solutions for the motorway alignment that respond appropriately to the cultural and physical context of the site, and to be a 'part of' Manukau City rather than a dividing element.

Character

- To develop themes for the motorway alignment which are locally distinctive and place based to provide a memorable experience for motorists and the community.

Choice

- Ensure diversity of environments, routes and activities are made available.

Connections

- To retain and improve the connectivity of the local movement network along and across the motorway corridor in Manukau City linking people and places.

Creativity

- Ensure innovative and imaginative design solutions.

Custodianship

- Employ a sustainable approach to development of the motorway corridor in Manukau City including the "triple bottom line" approach to environmental, social and economic sustainability. This will preserve built and natural environments while ensuring a safe, buildable and easily maintainable built outcome.

Collaboration

- Develop partnerships between public and private sectors in a collaborative design approach with key stakeholders, which will lead to a process of shared community ownership of project processes and outcomes.

Figure 3.9 - Tapa Cloth



04 Context/Analysis

4.0 Context of the SH20 Manukau Extension

The motorway passes through several distinct landscape character units.



Figure 4.1 - Context of SH20 Manukau Extension

4.1 Suburban Character Area

- Generous buffer space between SH1 and residential areas east of SH1 available to integrate additional infrastructure and improve environmental amenity;
- Elevated above SH1 with views westward along the SH20 alignment and to TelstraClear Pacific Events Centre;
- Church of Latter Day Saints retaining wall has potential to contribute to character of the area;
- Off-ramp to Redoubt Road signals entry to suburban area; and
- Additional infrastructure closer to the residential areas may elevate noise levels and decrease environmental quality.



Figure 4.2 - Aerial photographs of the suburban context of SH20 Manukau Extension

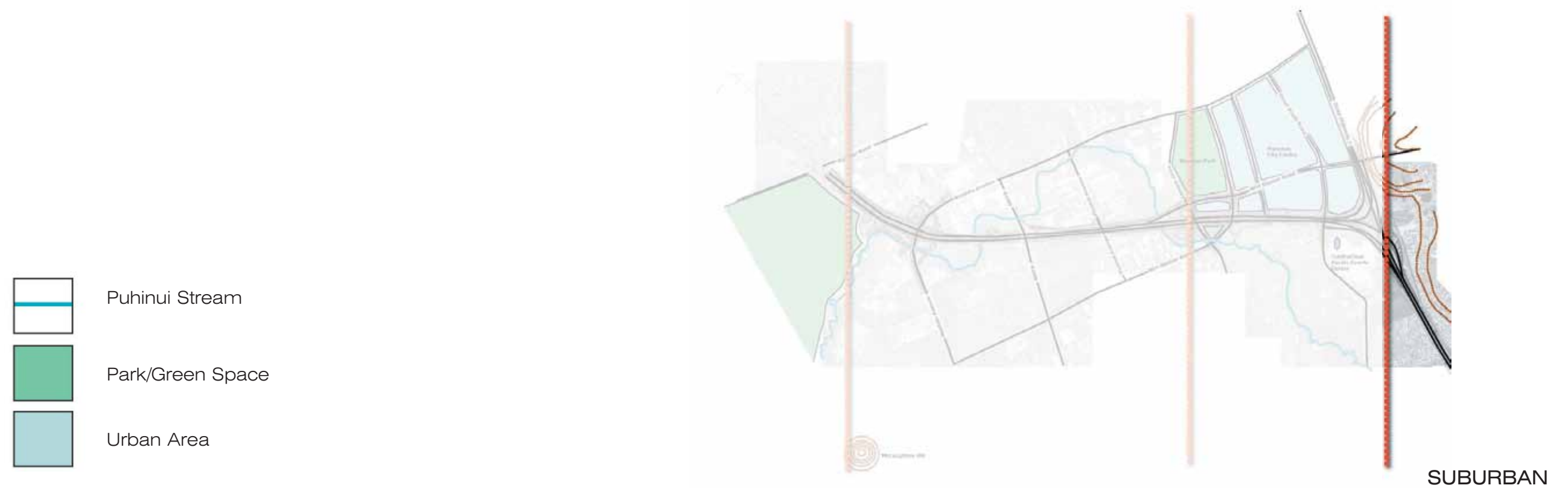

Figure 4.3 - The context of the suburban character area to SH20 Manukau Extension



Figure 4.4 - Aerial photographs of the urban/civic context of SH20 Manukau Extension

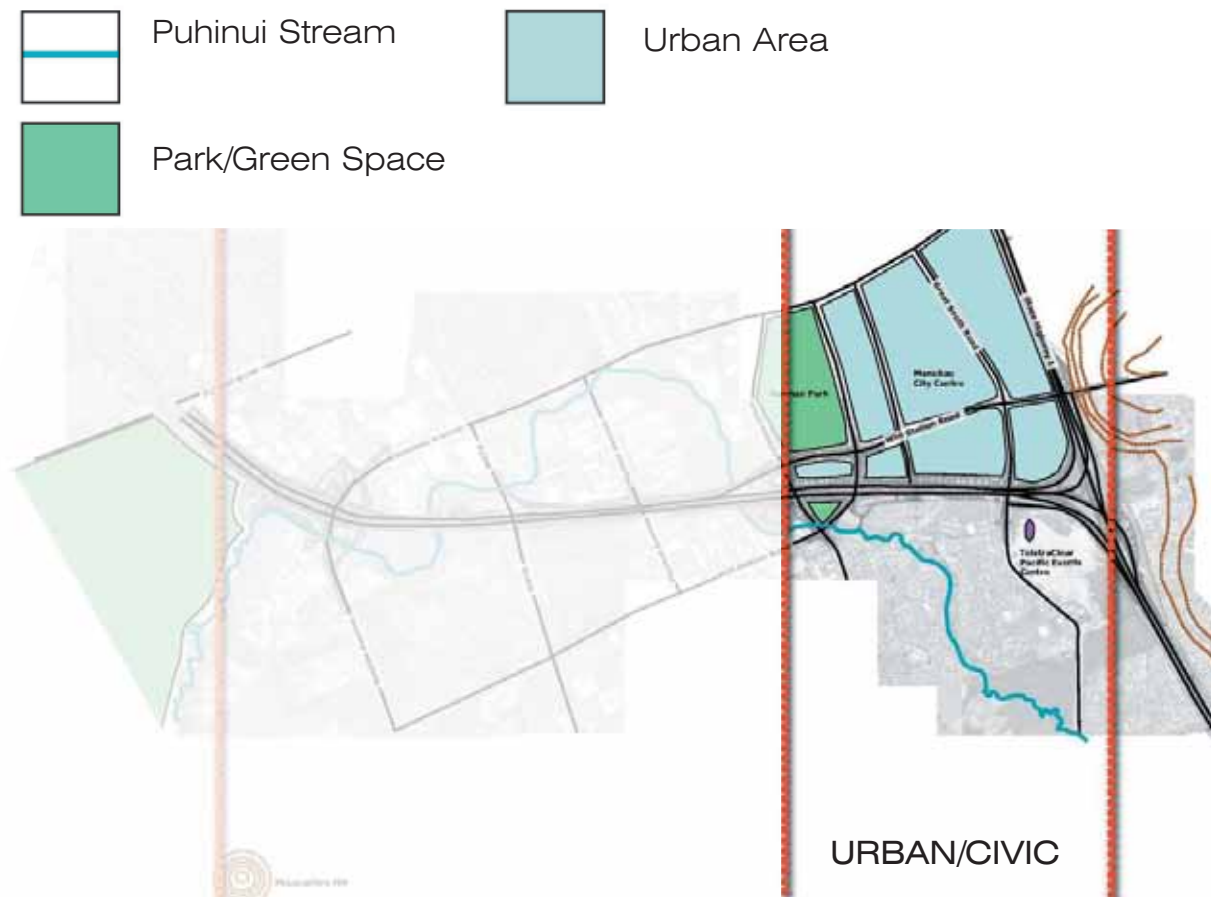

Figure 4.5 - The context of the urban/civic character area to SH20 Manukau Extension.

4.2 Urban/Civic Character Area

The SH20/SH1 Interchange and Sections of SH20 and SH1

- This is an important gateway and entry/exit from Manukau City to SH1 and along the SH1 route into Auckland City. Points beyond it on the SH20 alignment must be clear and comprehensible at speed;
- Includes a complex series of overpasses and underpasses within a short space of time in terms of the driver journey that represent a large amount of infrastructure and vertical elements, including opportunities to incorporate character defining elements; and
- The interchange encompasses a large area of land which needs to be graded, sculpted and planted to accommodate the infrastructure.

The TelstraClear Pacific Events Centre

- This highly visible landmark building provides an important cultural reference at the interchange area and features Pacifica architectural forms, patterns and artefacts.

Residential and Development Areas Adjacent to the Proposed Motorway

- Existing residential areas to the south of SH20 are set back above and away from the motorway, so are unlikely to suffer receive any ill effects of the motorway alignment; and

- Future developments on land immediately south of the motorway beside Barrowcliffe Place and adjacent to the motorway, at the south end of Hayman Park are located above the level of the motorway, but may experience varying levels of effects from noise and visual disturbance;

Manukau City Centre and Hayman Park

- The Manukau City centre has the potential to become a more vibrant 'urban heart' for the city as outlined in the Masterplan, which sees the centre as 'place to work, shop, play and live';
- The motorway and future rail connection will play an important part of this urban regeneration and the urban and landscape design treatment of the motorway should reflect these connections;
- A large portion of this area will be in cut so opportunities to enhance views to landmark buildings will be challenging;
- Hayman Park, an important green space on the edge of Manukau City centre, will be dissected by the motorway alignment. The parts that remain should be accessible by a variety of different modes and contribute to the Manukau City public open space network; and
- A stand of pin oaks in Hayman Park will be affected. These will be assessed by a qualified Arborist to recommend methods for their retention, relocation or replacement where practicable.

Rainbows End Theme Park

- Features highly visible character buildings and structures above the level of the motorway; and
- A line of mature trees between the alignment and Rainbows End will be affected.

4.3 Industrial Character Area

- The route passes through areas with exposed and underlying volcanic geology and views to volcanic landmarks;
- The motorway provides important logistical infrastructure for these areas. As an industrial/commercial and extractive industries precinct, it is a vital part of the local and national economy;
- Characterised by typically large built forms, extensive outdoor storage areas, extractive industries and rail sidings;
- The NIMTR forms a ‘hole’ in the otherwise plantable areas either side of the motorway, opening views through to the wider landscape;
- This section features the Plunket Avenue bridge only, which is a long, twin span bridge that is inclined both sides, providing opportunities to accentuate its potentially elegant form;
- The vertical alignment provides elevated areas with opportunities to direct views along the length of the alignment and to the larger landscape;
- Puhinui Stream corridor, walkway and tributary interfaces with the alignment providing opportunities for additional passive surveillance from the motorway and character plantings; and
- Several storm water ponds and associated wetlands are proposed either side of the alignment, providing opportunities to treat storm water runoff, further characterise the alignment, and improve environmental amenity.



Figure 4.6 - Aerial photographs of the industrial context of SH20 Manukau Extension



Figure 4.7 - The context of the industrial character area to SH20 Manukau Extension

4.4 Rural Character Area

- The rural areas, particularly those under the Auckland Airport flight path and the Puhinui Stream corridor, feature open fields to the west of the alignment;
- This area represents a change from the highly developed and altered landforms and large built form of the industrial precinct; and
- The Auckland Airport flight path introduces an element of overhead views, which in terms of the overall treatment and patterning further adds to the exposure of Manukau to a wider audience.



Figure 4.8 - Aerial photographs of the rural context of SH20 Manukau Extension

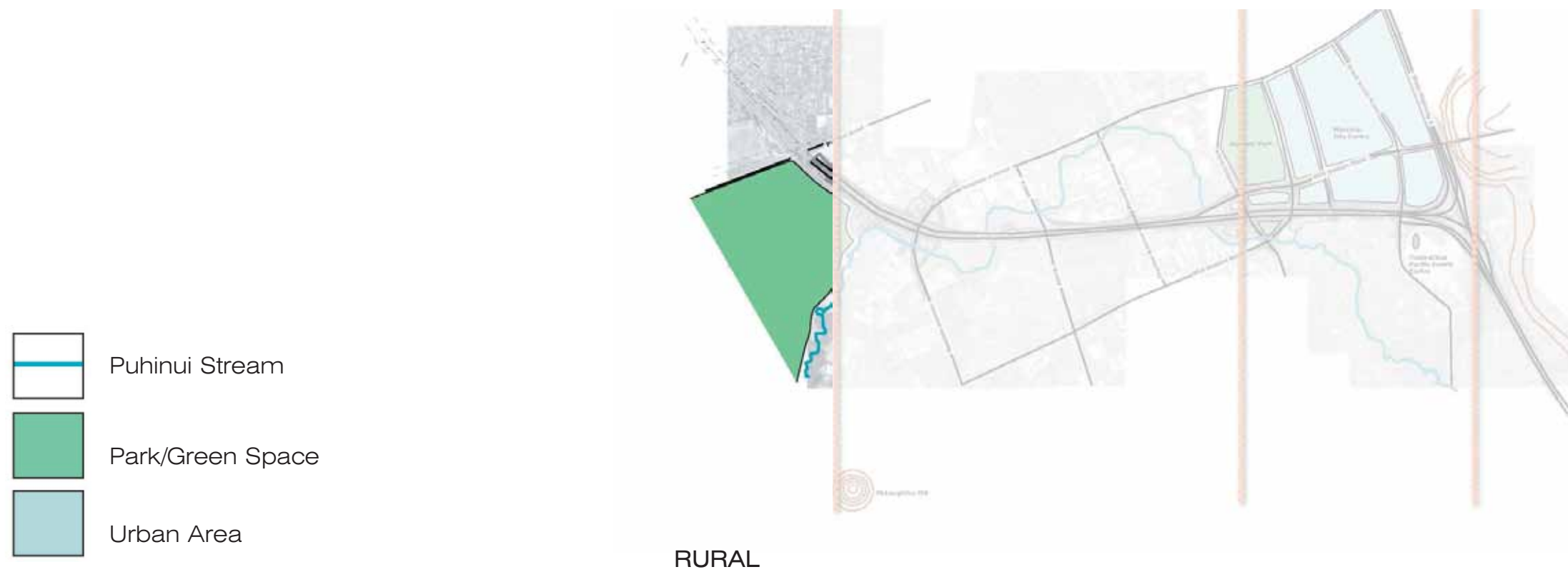

Figure 4.9- The context of the rural character area to SH20 Manukau Extension

4.5 Puhinui Stream Corridor

- The Te Araroa Trail along the Puhinui Stream corridor is of national significance;
- Much of the stream is in a degraded state with heavy weed infestation and poor visual connections. A management plan has been prepared by others to restore the corridor and incorporate all weather walkway facilities;
- The re-alignment of a section of the stream at the western end of the site will involve the reconstruction of stream banks, which will result in modifications to plant growing environments; and
- The motorway alignment and side roads cross the stream in several locations and will require special treatments to ensure the safety and comfort of walkway users including ensuring high levels of surveillance from surrounding properties.
- Relocation of Puhinui Walkway where passage under the motorway plus Wiri Station Rd Extension is not feasible. In this situation, an alternative route will be planned.



Figure 4.10 - Photographs of the Puhinui Stream corridor in context to SH20 Manukau Extension

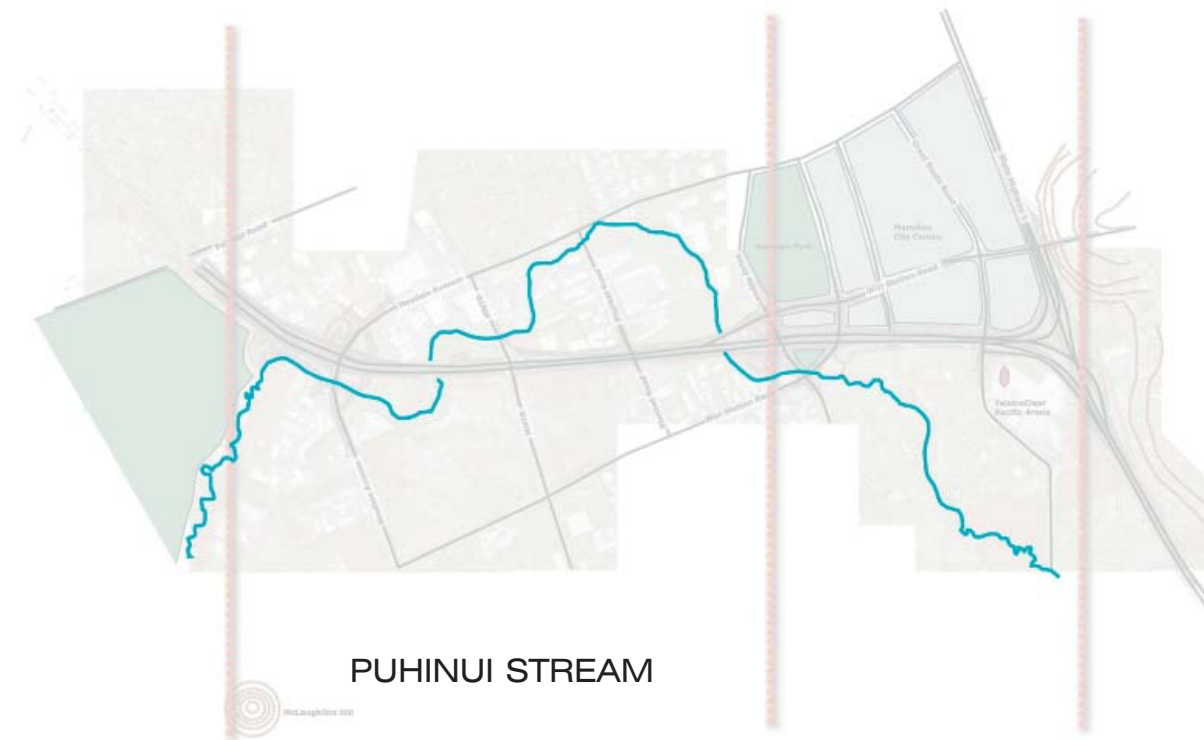
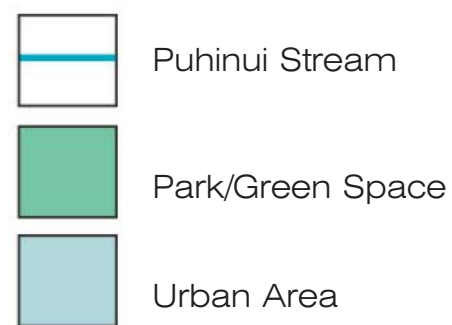

Figure 4.11 - The context of the Puhinui Stream Corridor to SH20 Manukau Extension

4.6 Views and Lines of Sight

The proposed motorway alignment travels through areas of cut (below grade) or on fill or elevated structures. This pattern of enclosure and exposure provides opportunities to characterise enclosed areas, and to frame and capture views off site to urban and rural panoramas, landmark buildings and natural features.

- Elevated components provide opportunities for views previously unavailable such as from the Redoubt Flyover, bridges crossing SH20 and bridges over the NIMTR and Nesdale Avenue;
- Views to key landmarks such as the TelstraClear Pacific Events Centre need to be maintained from all angles;
- Views into industrial sites that are undesirable will require special attention such as screen planting;
- Views from residential areas above the motorway, east of SH1, will require special attention;
- Clear and unimpeded lines of sight for motorists to ensure safe merging with other traffic and the ability to see ahead to survey traffic activity is an important component to guide appropriate solutions for planting design and placement of structures and motorway furnishings; and
- The Redoubt Flyover is a potential gateway element. Views to it from all directions should be protected

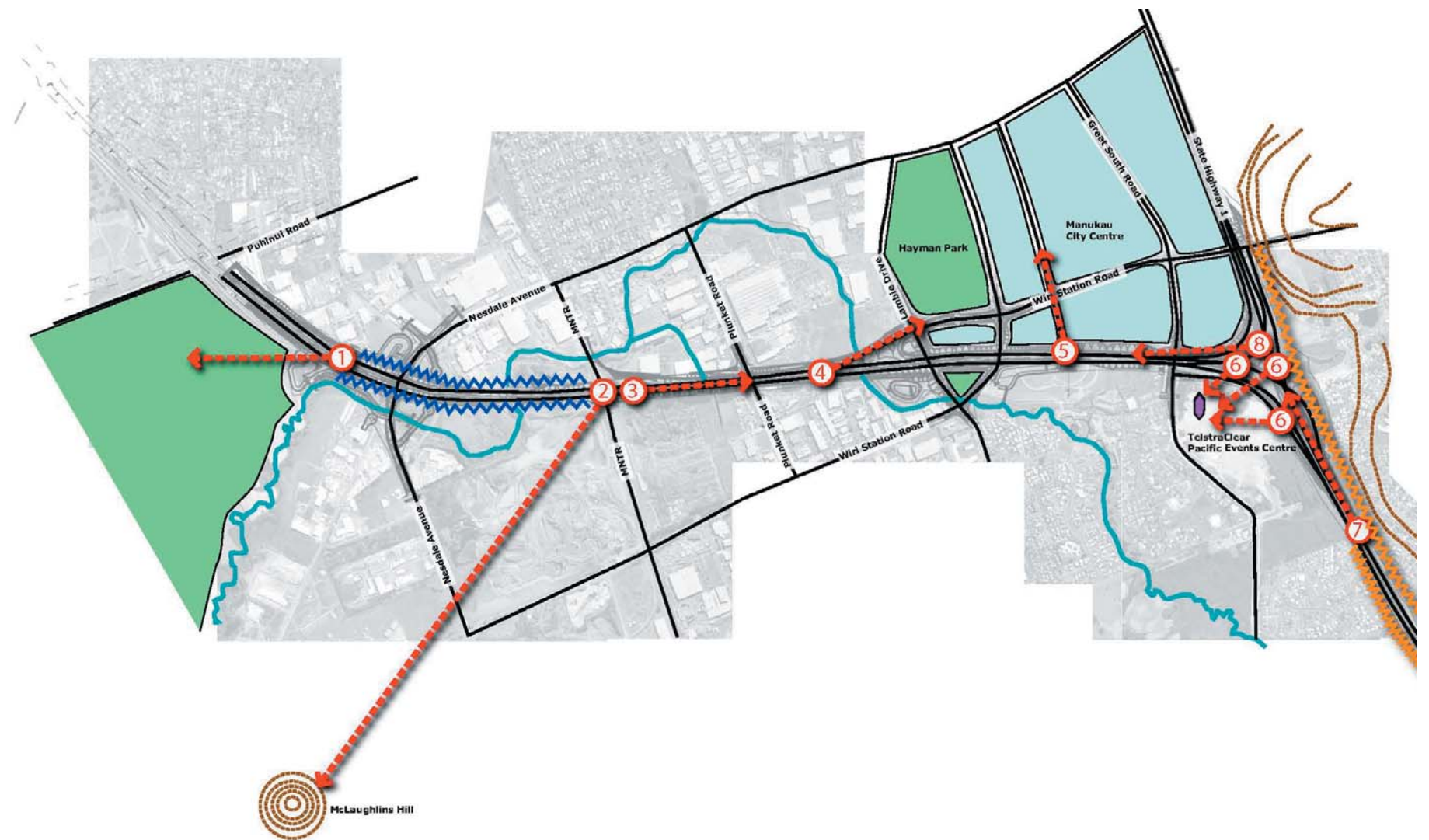
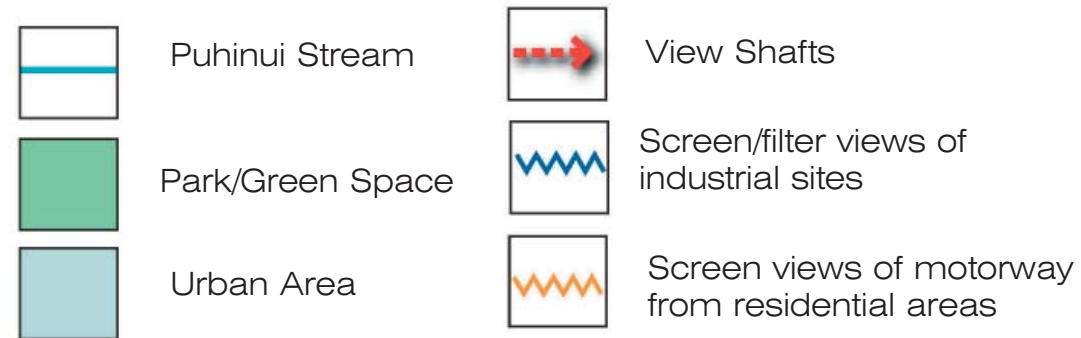

Figure 4.12 - Views, lines of sight and views screened



- 1) Rural panorama across cultivated fields towards Manukau Harbour and Airport
- 2) Elevated Views to McLaughlins Hill- Key volcanic landmark
- 3) Long views to hilly residential backdrop
- 4) Gateway views to Manukau City Centre
- 5) View from Barrowcliffe Bridge to Manukau City Centre
- 6) Views to TelstraClear Pacific Events Centre
- 7) Views to Redoubt flyover
- 8) Elevated views from Redoubt Flyover west along the alignment

4.7 SH20 – ‘The Volcanic Highway’

An important contextual element for the Manukau area is the effect that the underlying volcanic geology has had on the formation of the landscape and its character for the full length of the proposed SH20 alignment as it passes through the Auckland volcanic field. This opportunity offers strong design theming potential.

- Volcanic cones, explosive craters, lava flows and other elements including nearby stone fields, provide vital cues to characterise potential landscape design elements and preserve/frame views to assist place-making and way-finding; and
- Opportunity to develop a “Volcanic Highway” theme as has been done elsewhere in New Zealand with highway branding exercises.



Figure 4.13 -Aerial photograph of ‘The Volcanic Highway’



Figure 4.14 - Volcanic rock



Figure 4.15 - McLaughlins Hill



Figure 4.16 - McLaughlins Hill

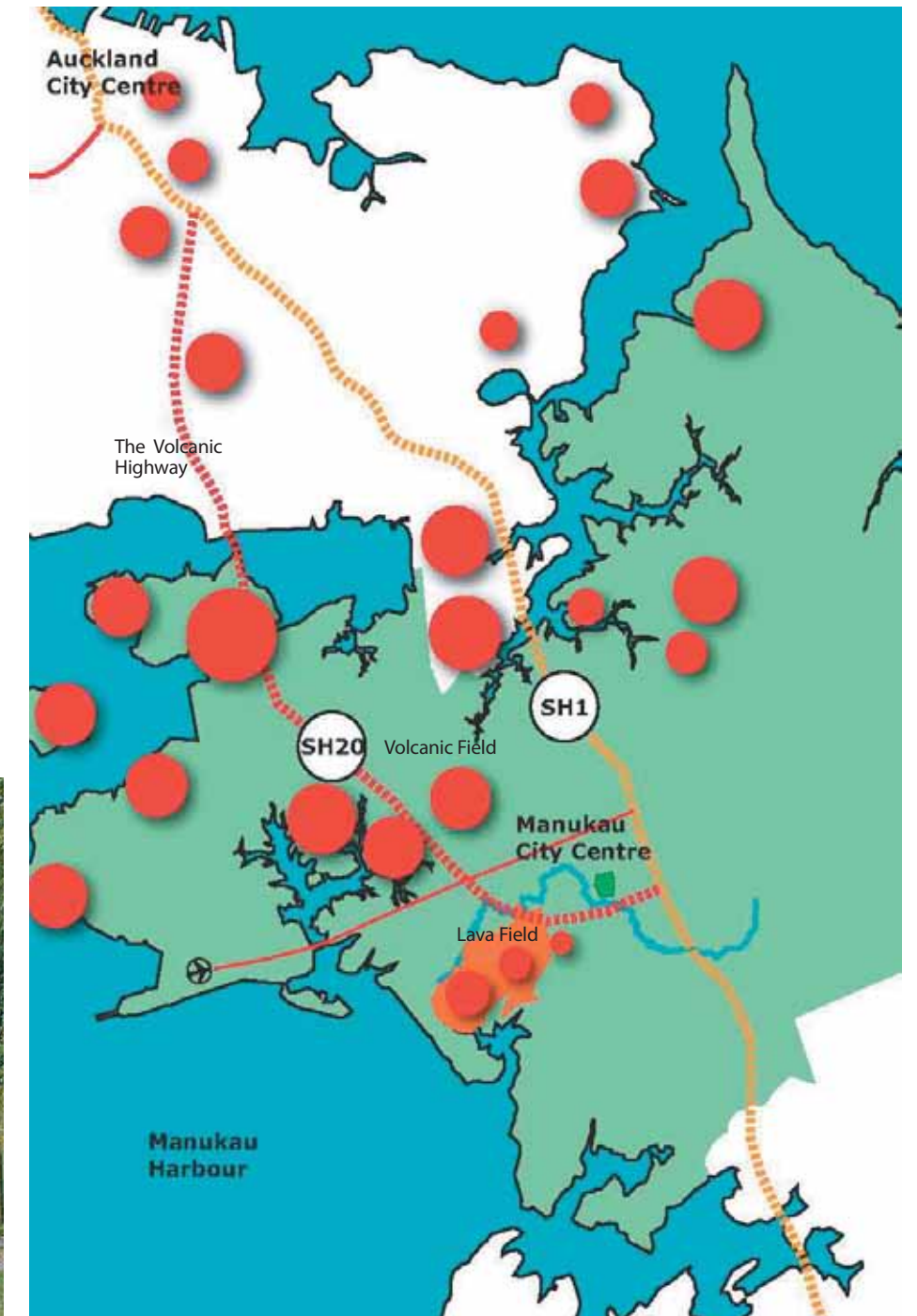

Figure 4.17 - Location of Volcanic cones in relation to SH20 Manukau Extension

05 Design Cues/Triggers



Figure 5.1 - Tapa Cloth

5.0 Landscape and Urban Design Cues

The urban and landscape design for the SH20 Manukau Extension takes its cues from engineering design parameters and opportunities and constraints from the physical and cultural context of Manukau City.

- This is a linear shaped design on a large scale which requires bold gestures that can be “read” at speed and from a distance;
- The Maori and Pacific peoples that inhabit the area, and particularly their graphic/visual motifs, provides strong inspiration for the inclusion of colours and forms that are specific to this project;
- Proximity to the Manukau Harbour, nearby pockets of native forest and expansive rural areas and the Puhinui Stream corridor provide opportunities to connect habitats and enhance urban ecology;
- The landscape and land uses along the alignment provide distinct character types which can drive the development of appropriate landscape and urban design solutions;
- The existing city form of towers and landmark structures (MCC offices, TelstraClear Pacific Events Centre, Rainbow’s End) provide local identity and opportunities for way-finding;
- The close spaced bridge sequences set up a rhythm and pattern of crossings and underpasses which can be read as a comprehensive ‘set’ of elements; and
- The sequences of travelling through areas of cut (below grade) and on fill or elevated structures (above grade) provide opportunities to characterise enclosed areas and celebrate views to landmarks and panorama’s.

06 Integration of the Motorway into Manukau City

6.0 Key Considerations

The urban design solution will ensure the motorway alignment improves the connectivity of areas either side and along its length such as connections to residential and commercial areas, areas of employment and recreational and community support facilities.

Motorways are generally hostile environments for pedestrians and cyclists. They may, if not well considered, divide communities and negatively impact upon the lifestyles of residents either side.

The routes provided for these road users should be easily accessible with provision of generous, well appointed pavements with good landscape and urban amenity. Connections should be direct and as short as possible with few obstructions.

Landscape elements either side of the motorway such as plantings, materiality, green open spaces and furnishings, should be continuous. These elements should be visible from the motorway to give the impression that the urban environment is 'intact'.

Potential 'gateway' areas should be characterised appropriately to heighten expectations and signal transition another area where land uses and road speeds are different.

Areas of enclosure should be visually stimulating and provide references to the 'make up' of the city, its landscapes and its peoples. Areas where views are possible should offer opportunities for orientation.

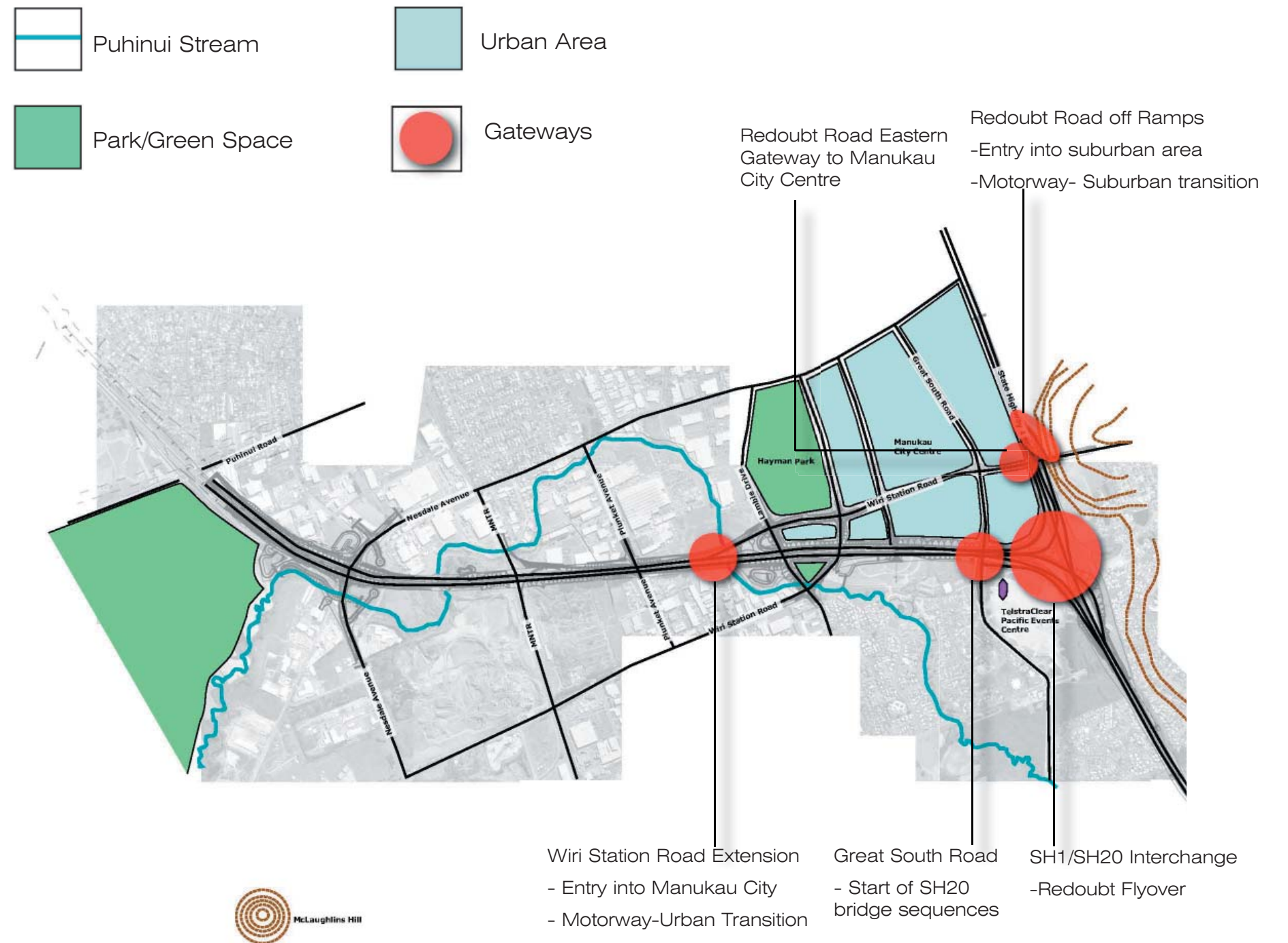

Figure 6.1 - SH20 Manukau Extension gateways

6.1 Key Connections

The Urban Civic Character area includes Barrowcliffe Place Bridge, which will connect existing and proposed residential areas with the Manukau City centre. The route should offer high levels of amenity that extends the character of the Manukau City centre and be an attractive route for pedestrian and cyclists. Paving treatments, plantings and furnishings will be aligned with MCC's aspirations for the Manukau City Centre.

Wiri Station Road Extension will provide the 'western entry' into Manukau City. This should present opportunities to integrate a 'gateway' gesture that supports the identity of Manukau City. This 'gesture' will capture opportunities to characterise infrastructure elements such as culvert headwalls or light wells. Sculpted landforms and planting arrangements and sequences will announce the change from travelling through an industrial corridor to arrival into an important urban civic centre.

The journey between Great South Road and Lambie Drive is undertaken in an area of cut, travelling through a sequence of bridges in quick succession. Views to landmark buildings and natural features beyond the site will be obscured. Embankments either side will feature sculpturally graded earthworks and structural plantings. Bridges will be embellished with references to Pacifica forms and motifs. Bridge abutments and retaining walls will integrate references to the underlying geology through the use of textures and materials.

Hayman Park, a valuable green open space on the edge of Manukau City centre will be severed and partitioned by the motorway alignment and Wiri Station Road Extension. The legacy of this space should be retained as a green park-like wedge either side of the alignment. The left over spaces should be treated as recreational open space reserves and connected both physically and contextually across the motorway to ensure continuity and the retention of amenity values for Manukau City centre.

Street tree plantings for all roads crossing the motorway alignment are pre-determined by MCC (see Planting Schedule). Each street will feature specific trees, which will continue across the motorway, and if possible, will be visible from SH20. Tree plantings outside the designation will be undertaken by M.C.C.

Additional infrastructure including a series of ramps, an underpass and the Redoubt Flyover will be incorporated into the SH1/SDH20 interchange. The Redoubt Flyover is a curving elevated structure with the potential to offer an elegant gateway element to the SH1 sequence of elements that punctuate the journey into both Auckland and Manukau City. Plantings between the infrastructure will marry in with the existing SH1 plantings either end of the project area, and in the centre, structural plantings will characterise the interchange.

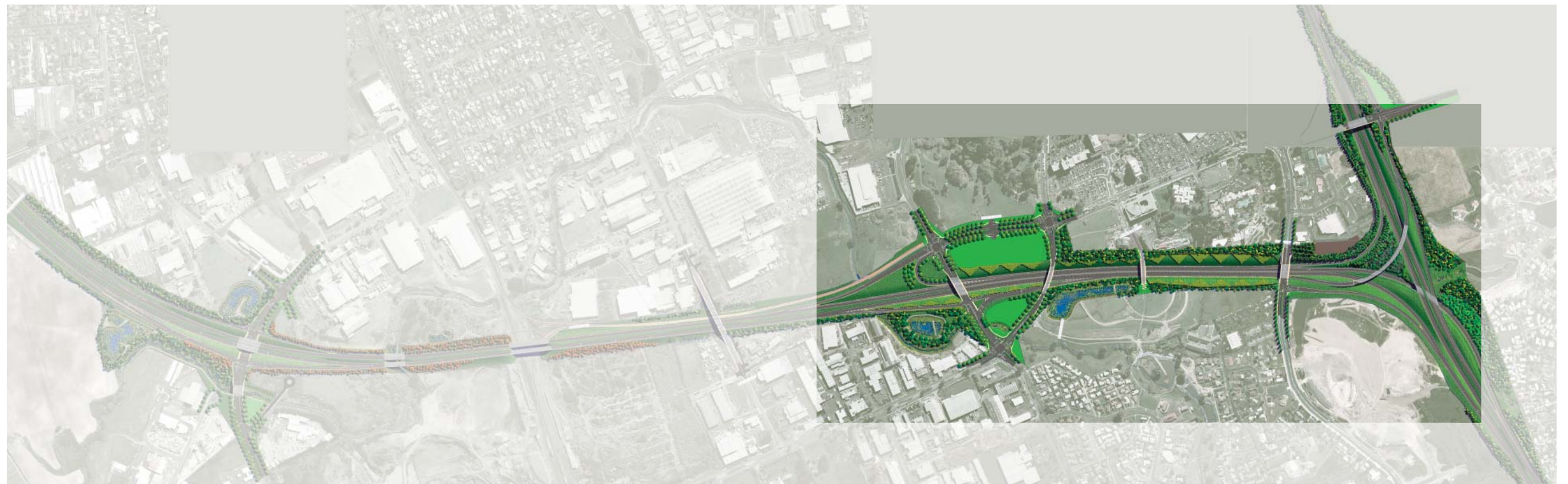
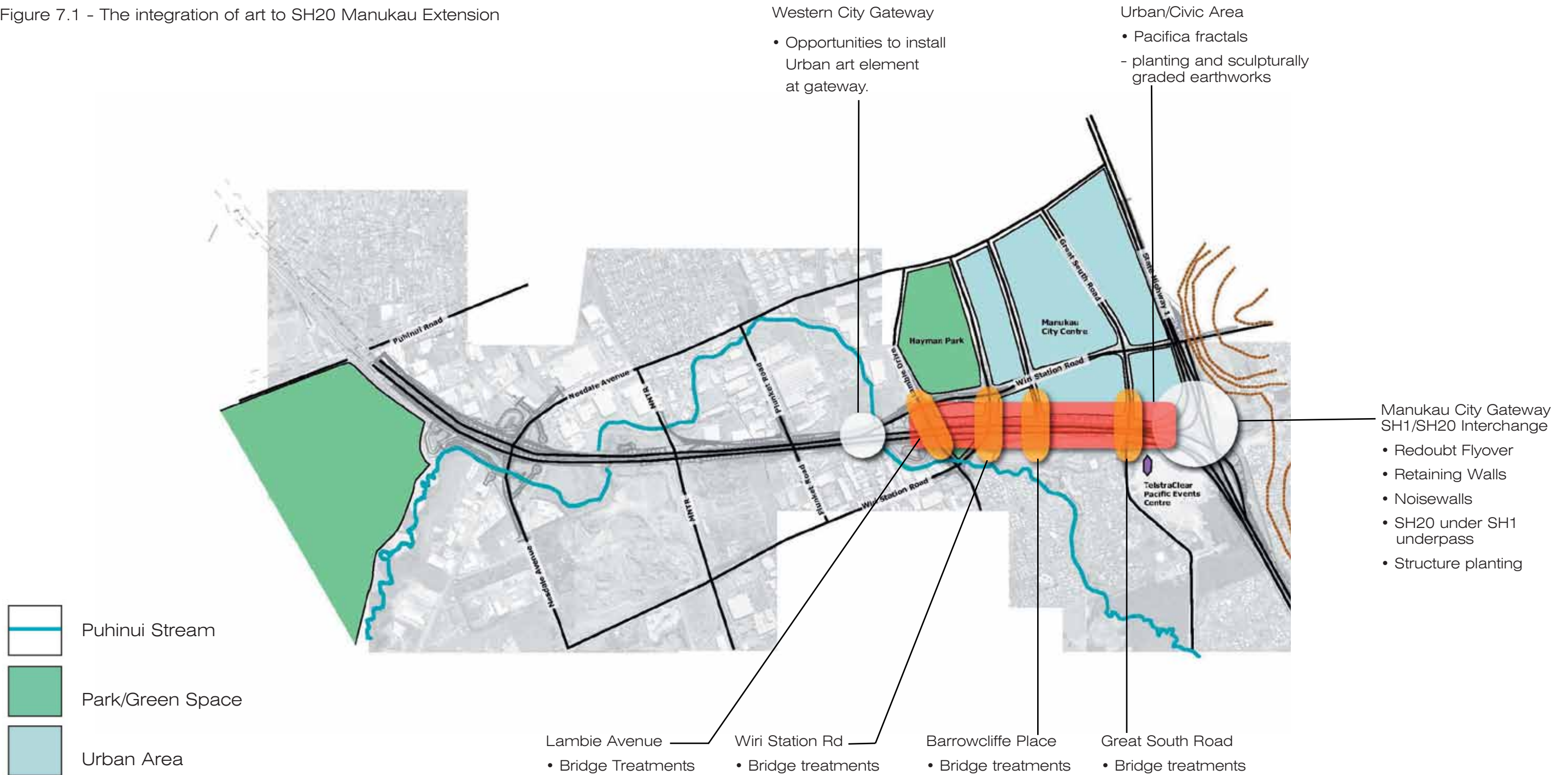

Figure 6.2 - Key connections in Urban Civic Area.

07 Integration of Art into the Motorway Environment

Figure 7.1 - The integration of art to SH20 Manukau Extension



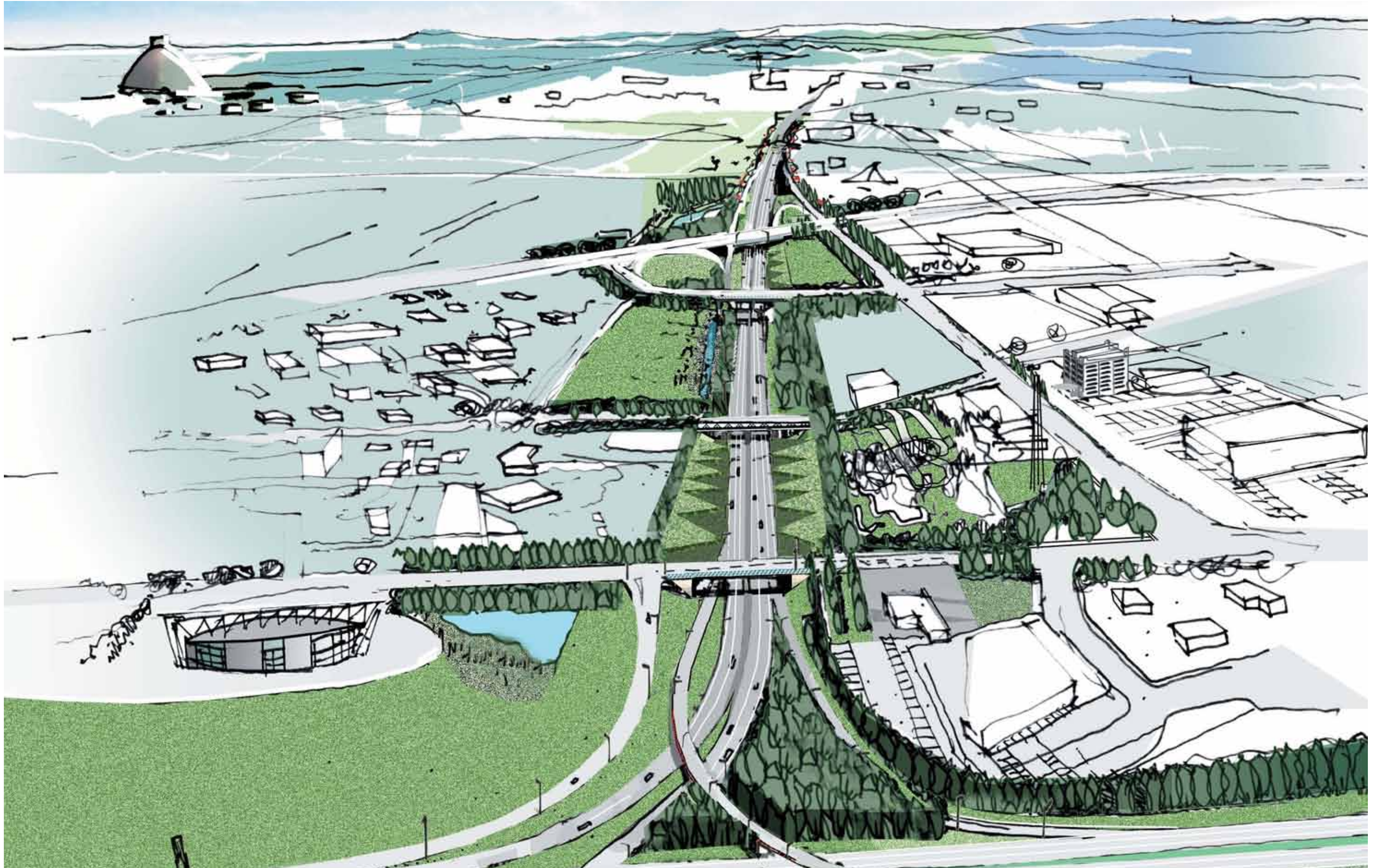

Figure 7.2 - Aerial perspective concept sketch looking west over SH20.
Note: indicative only - final design subject to further investigation.

7.0 Integration of Art

Integration of art and visually interesting elements into the engineering, urban and landscape design for the SH20 Manukau Extension involves more than just a token placement of sculptural 'artefacts'.

This is a landscape/urban design on a grand scale which takes its design cues from the physical opportunities and constraints of the site and surroundings. The design solution for the integration of art into the motorway environment is driven by the physical and cultural context of Manukau City to ensure a 'sense of place' is achieved.

Drawing art out of the landscape and integrating it into the infrastructure design creates opportunities for the development of structures, surface finishes, planting and lighting effects that are site specific and coordinated.

Art elements can assist with the telling of 'the story' of this landscape, of Manukau City, and of its people. The motorway landscape provides an enormous 'canvas' on which this story can be set.

- Art elements can help to establish a rhythm and sequence for the motorway, drawing from the major engineering works of bridges and other infrastructure elements to smaller gestures along the route.
- These design gestures must not only be bold and relatively simple to be 'read' by users on the motorway but memorable and interesting for the 'static' audience who live and work either side of the motorway;
- Design elements must not be distracting to motorists, but rather, they should stimulate and inform;
- The flight path of Auckland Airport should be considered in preparing a design approach which can also be 'read' from above by passengers on overhead flights;

- Manukau City has a rich history of Polynesian settlement and historic occupation by Maori. These cultures enrich the character of Manukau City and will contribute to the formation of a 'gateway' gesture into Manukau City;
- Polynesian tapa cloth and Maori fibre weaving provides strong geometry and links to Manukau City's 'Pacifica' cultural makeup;
- Pacifica geometry patterns and motifs are easily reinterpreted into the landscape as forms and colours with bold elements of positive and negative fields and can be adapted to earthworks, structures, plantings and other surfaces and features; and

- The strength of Pacifica iconography allows for adaption and abstraction to be emblematic of the cultures of Manukau City.

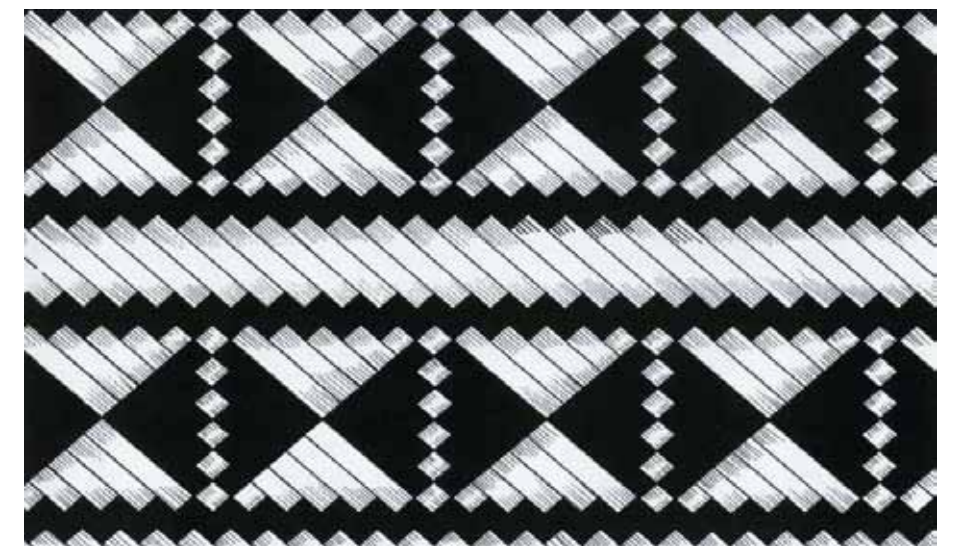
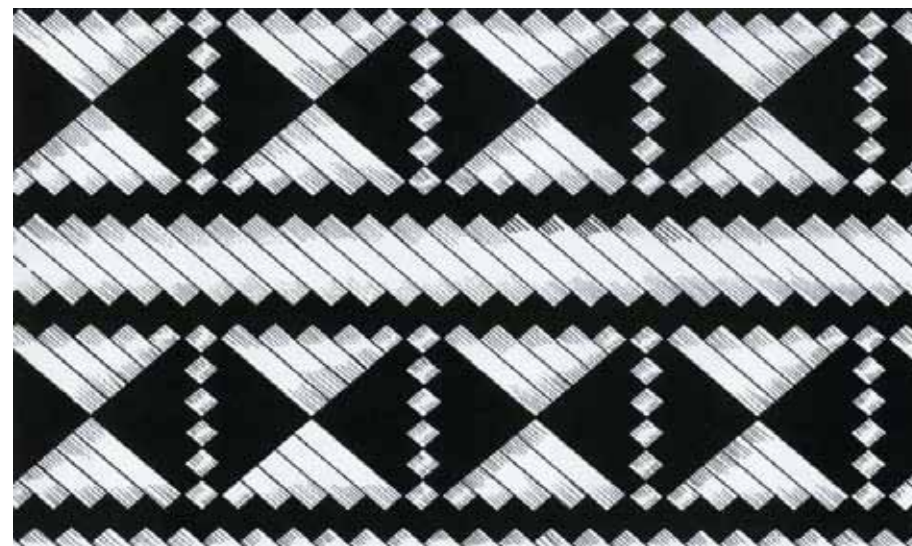
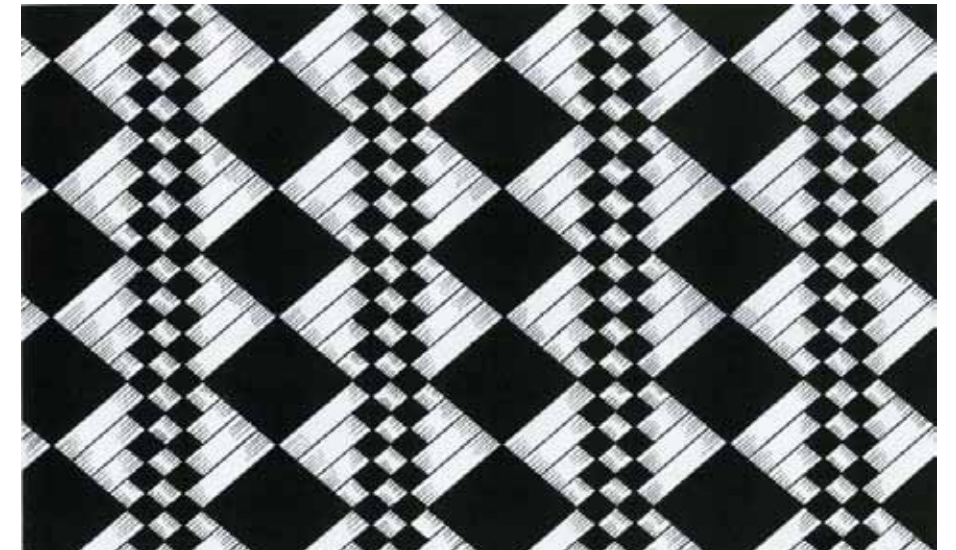
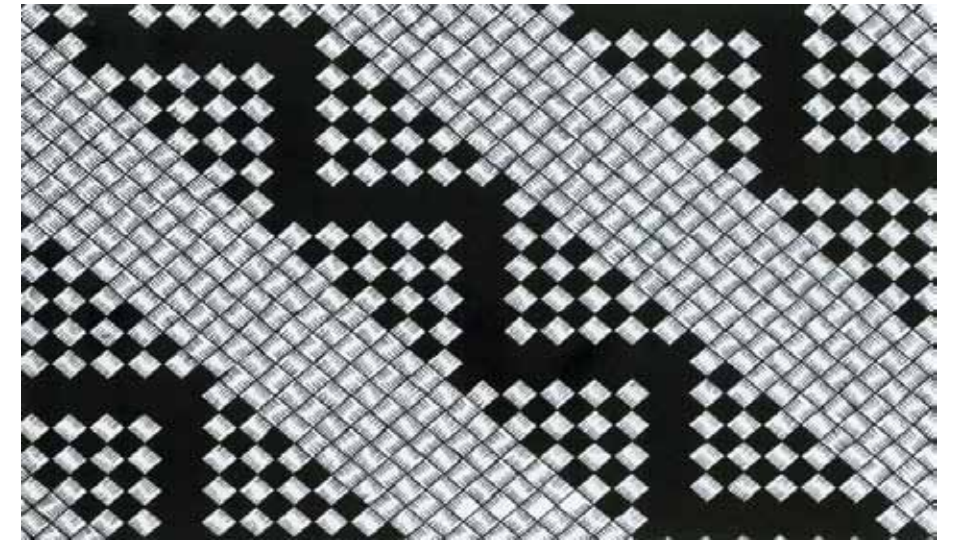
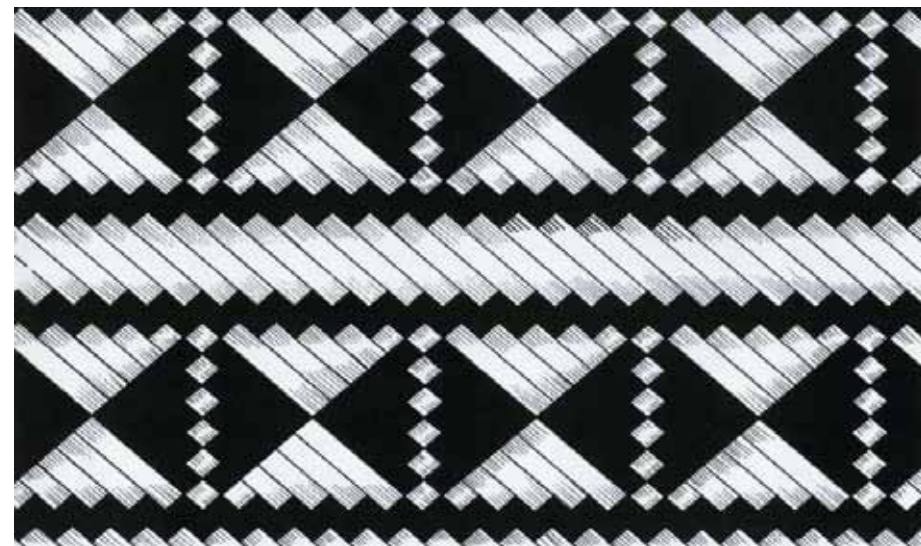
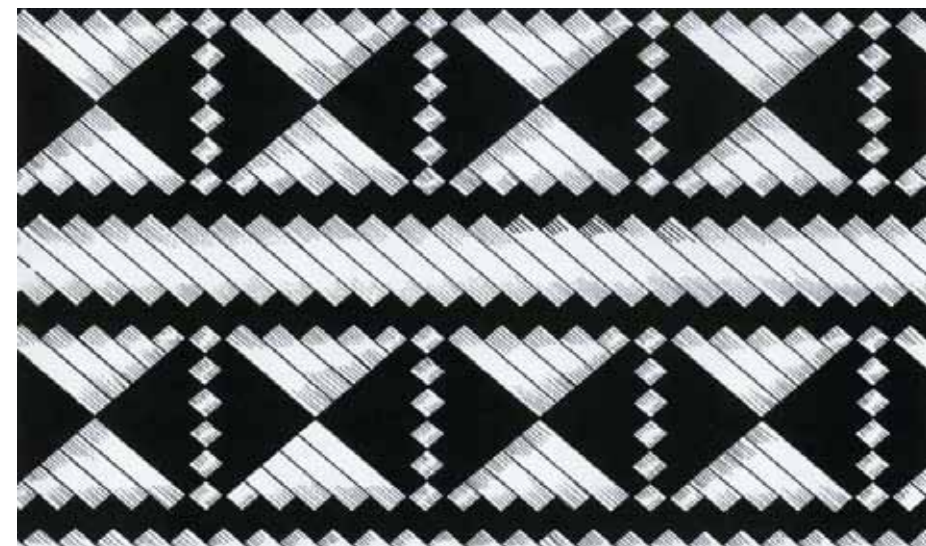
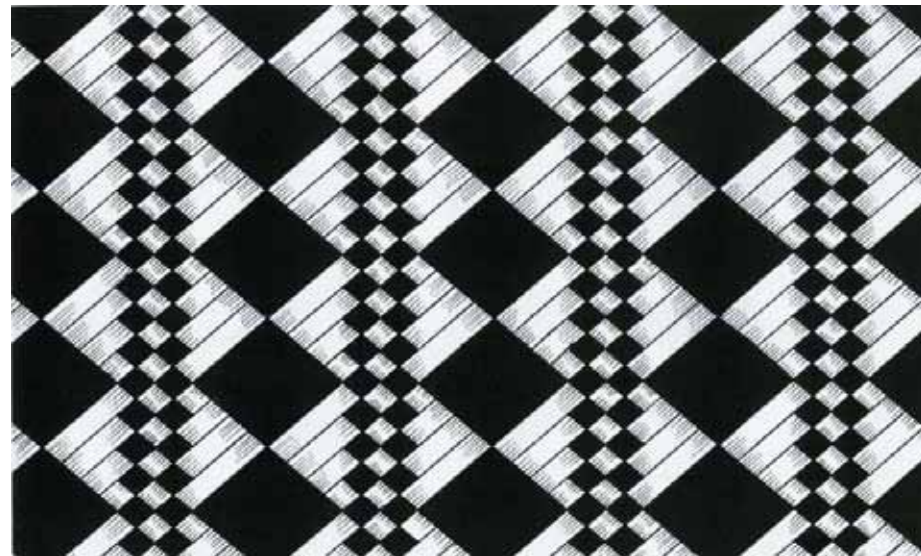
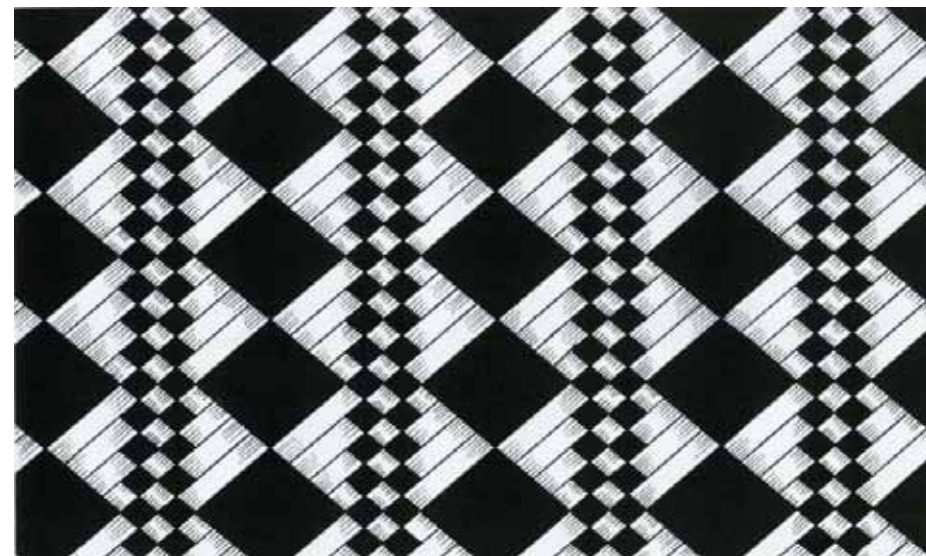
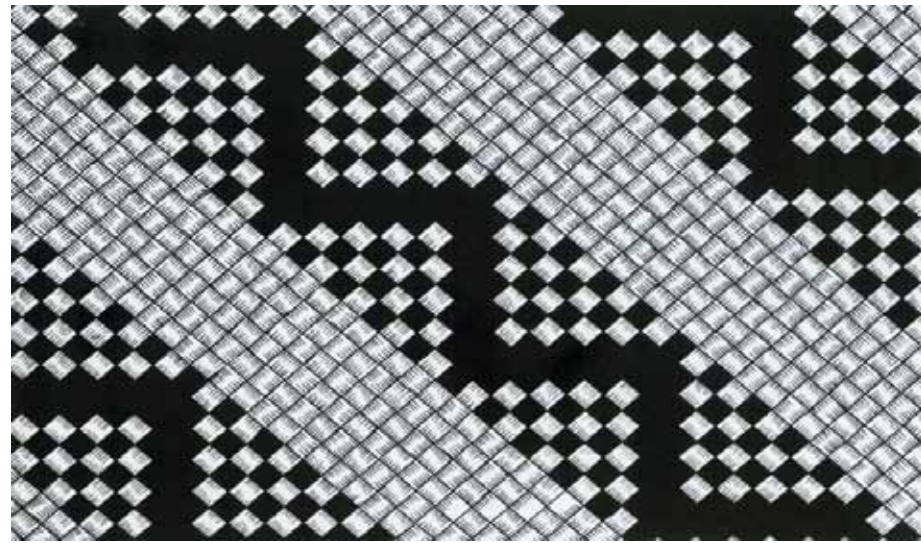
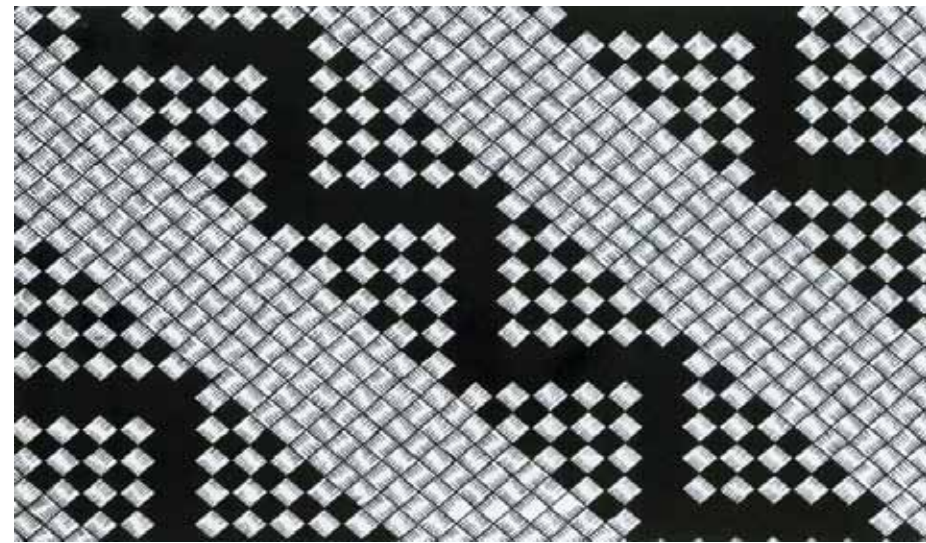

Figure 7.3- Maori weaving patterns



7.1 Community Acceptance

The development of integrated arts components will need to be undertaken in close consultation with community appointed representatives and Manukau City Council officers to ensure the best possible design outcomes and advocacy. Cultural motifs, colour systems or other culturally derived embellishments will need to be accepted and approved by the community prior to finalisation of concepts and advancement to detailed design.

Integration of a community lead arts programme into the motorway alignment will include the following:

- Culturally specific embellishments on the surfaces of retaining walls and bridge barriers;
- Planting arrangements;
- Materiality of bridge abutments;
- Design and colour of railings on bridges; and
- Feature lighting of key elements.

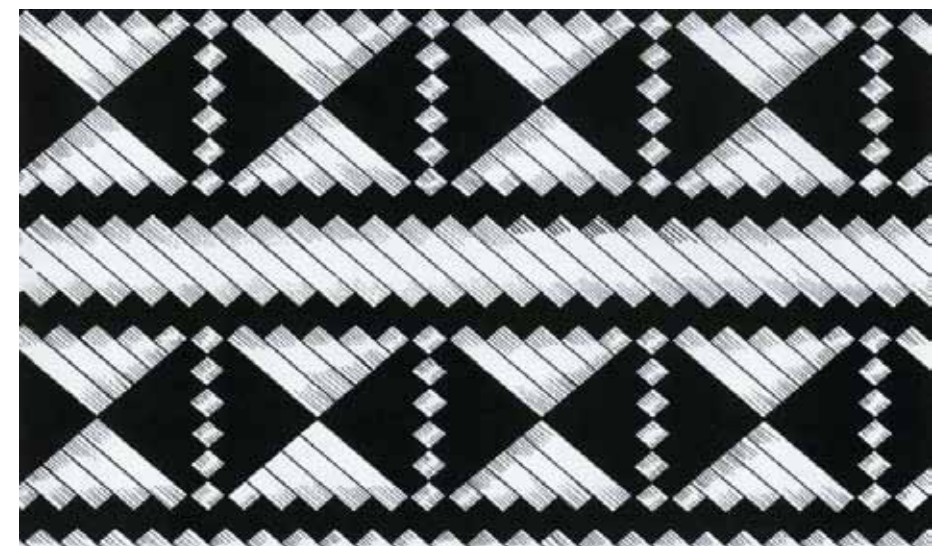

Figure 7.4 - Maori weaving patterns

7.2 Lighting

Opportunities will be considered to incorporate specialist lighting.

General baseline lighting levels and provision for carriageways, bridges and intersections are addressed by others and are not a consideration of this Urban Design Report except where specified to contribute to the theme of specific bridges.

Lighting Design Objectives

The design vision for lighting may include:

- Specialist lighting to highlight and enhance structural surfaces and forms with directional lighting and various lighting colours;
- Adopt cost effective, low energy, long life solutions. Where specialist lighting is proposed, consider timing of operating hours to reduce energy consumption and running costs; and
- Limit distraction and glare from lighting on traffic with careful placement, colour and wattage and screening where glare effects on traffic is a potential issue.

Lighting Design Concepts

Concepts for specialist lighting include:

- Retaining walls either end of the Redoubt Flyover – light surfaces from below;
- Rusticated retaining walls at Great South Road – lit from above, from underside of bridge;
- Spill through abutments with stone fill – lit from above, from underside of bridge;
- SH20 under SH1 underpass – light rusticated walls of underpass from above;



Figure 7.5 - Bridge Lighting

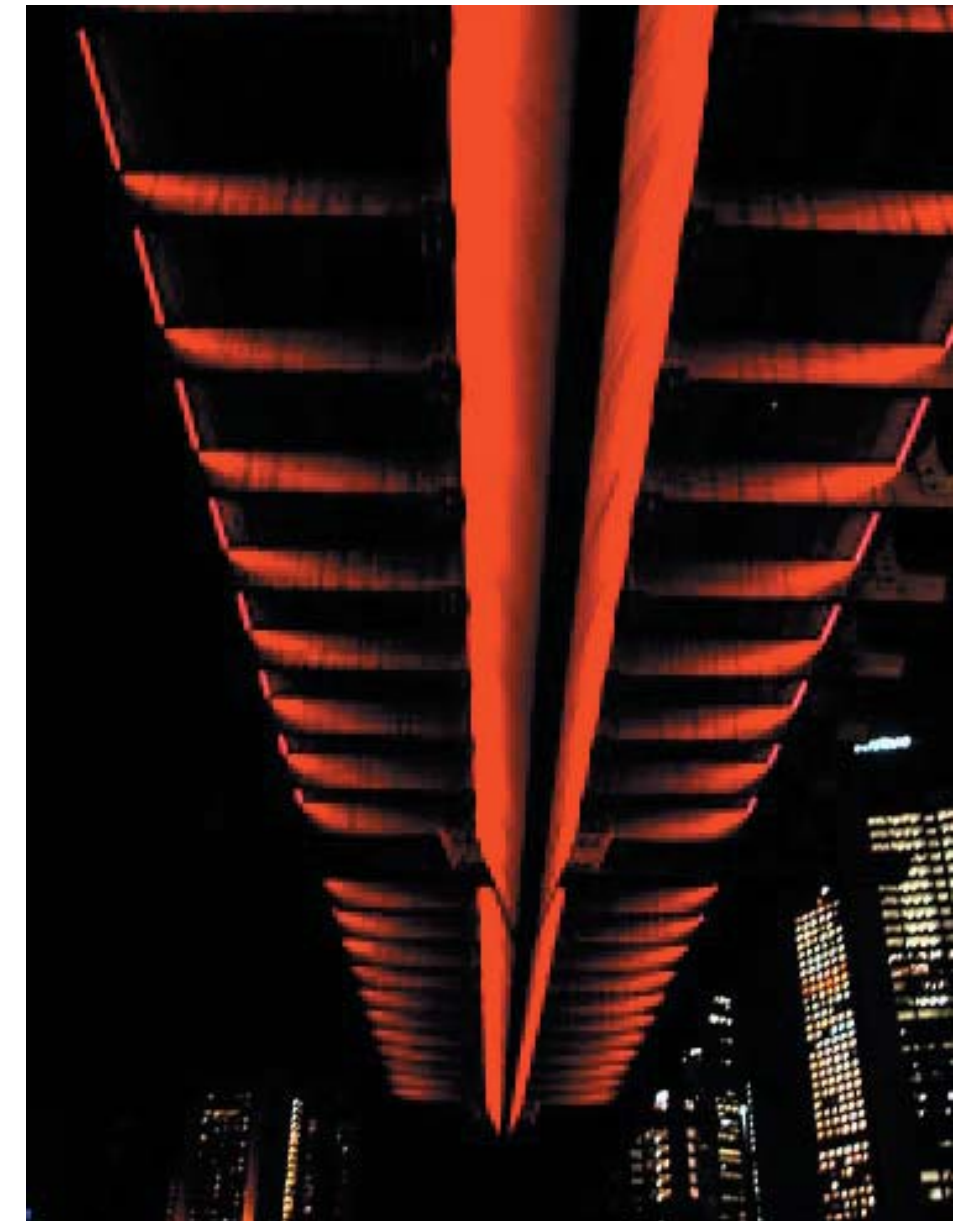

Figure 7.7 - Surface lighting on the underside of a bridge



Figure 7.8 - Lighting to highlight feature surfaces

7.3 Environmental Responsive Solutions

The landscape and urban design concepts are concerned with the improvement of environmental values in Manukau City arising from the opportunities that this project presents. These include, but are not limited to:

- Water sensitive urban design solutions (WSUD) for storm water ponds and associated wetland edges to capture, detain and polish storm water runoff and remove sediments from roadway surfaces prior to release into the Puhinui Stream and ground water systems;
- Native riparian plantings on the banks of the Puhinui Stream and storm water ponds that support the habitat of terrestrial and wetland fauna, take up sediments from overland flows and stabilise banks;
- The planting of substantial areas in native lowland forest species that contribute to urban ecology, movement networks for native bird species, take up carbon from the atmosphere and stabilise banks;
- Introduction of rare and endangered native plant species to provide safe areas for populations of these plants;
- Careful selection and location of plants that are native to the area and conditions, thus removing the requirement for irrigation and intensive management and maintenance;
- Mulching with natural materials that break down to soil and reduce soil moisture loss and weed infestation and the use of herbicidal sprays;
- A planting management objective that encourages self regenerating native plant communities;
- Minimisation of unnecessary cut and fill and the use of local materials to reduce cartage; and
- Promotion of low energy, long life lighting solutions.



Figure 7.10 - Native 'Highway Mix Planting'



Figure 7.11 - Riparian Area



Figure 7.12 - Wetland Sedges



Figure 7.13 - Tui (*Prosthemadera novaeseelandiae*)

7.4 Safety

The detailed design of the landscape and urban design component of this project will provide resolved design solutions to improve the safety of Manukau City and the motorway alignment. These solutions will follow CPTED principals outlined in Manukau City's 'Design Out Crime – Crime Prevention through Environmental Design Dealing with Public Realm Hotspots' and other common sense design considerations to meet the expectations of Manukau City and TNZ.

Surveillance

- Ensure the provision of clear sight lines between pedestrians/cyclists and vehicles on roadways, pavements and the Puhinui Stream Walkway through the protection of view corridors and the careful selection and location of plantings and streetscape furnishings;
- Motorway underpasses and culverts – ensure long straight approaches either side of these areas to provide opportunities for pedestrians to assess the situation and 'turn back' if necessary;
- Consider an alternative route for walkway where access under motorway + Wiri Station Rd extension does not allow opportunities to provide safe + reasonable access;
- Design out areas that are trapped between tall fences and screen plantings where crime can take place;
- Design out tall fences and walls to ensure a good public/private interface; and
- Design out hiding places and unlit areas that provide hiding places and are difficult to supervise.

Quality

- Design places that people are proud of, have a sense of ownership over and are less likely to vandalise.

Other

- Design non-slip and trip-free surfaces; and
- Restrict access to busy motorways and rail lines with the provision of visually permeable safety fences.

08 Structures - Bridges and Retaining Walls

8.0 Overview

The “hardscape” elements of the motorway including the bridges, retaining walls, abutments, gantries and safety barriers are the most obvious and visible manifestation of the urban form. The requirement for all observable elements to “offer a high degree of visual amenity from all viewpoints, including underneath such forms as bridges or retaining walls” means that an engineering driven aesthetic for these features will not meet the needs of the brief. It has been incumbent on the urban design team to work with the engineers to provide design embellishment and visual interest within the constraints of budget, safety and structural design criteria and ease of construction.

The aim has been to provide a coherent set of images across all hardscape elements which will serve to visually link them in an integrated package for the length of the alignment. There has been a blurring of the line between urban design, engineering and the integrated art approach.

The integration of the urban design team with the engineering team for this project has led to the inclusion of well considered “urban design elements” to bridge railings, undercroft areas, and the hardscape elements of the motorway including bridges, pavements, barrier walls, retaining walls and abutments which will help lift the visual experience for motorists and passengers as well as for residents and workers in neighbouring properties.

Design treatments which may be used to lift the basic hardscape infrastructure from a more utilitarian engineered approach to a memorable urban design experience include the integration of colours, patterns, textures and forms that are distinctive to Manukau City such as:

- texture on concrete and other surfaces;
- colour on steelwork elements such as railings;
- the development of rebates and shadow lines; and
- The use of bold and readable patterning along with more subtle pattern elements.

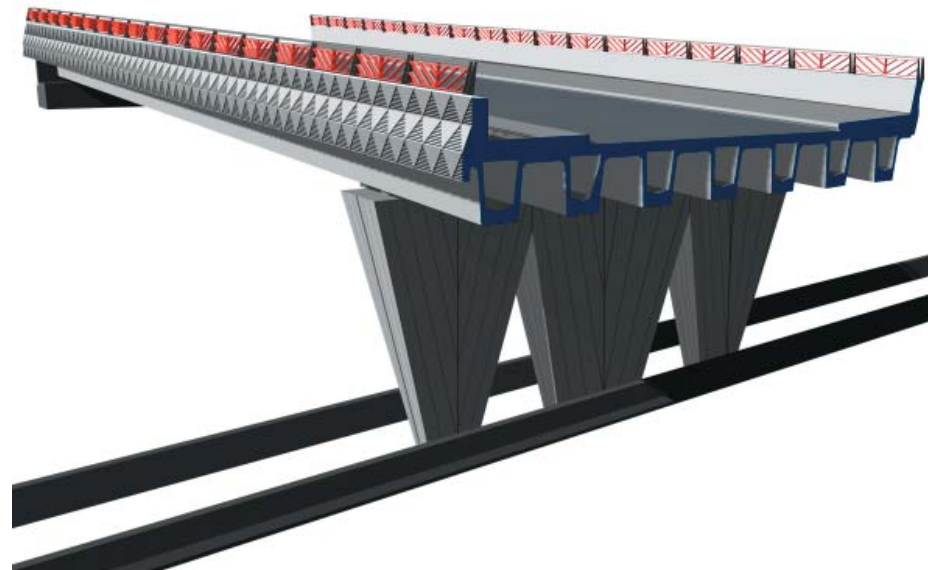

Figure 8.1 - Barrowcliffe Place bridge cutaway perspective



Figure 8.2 - 'Typical' Bridge over SH20 - Lambie Drive.

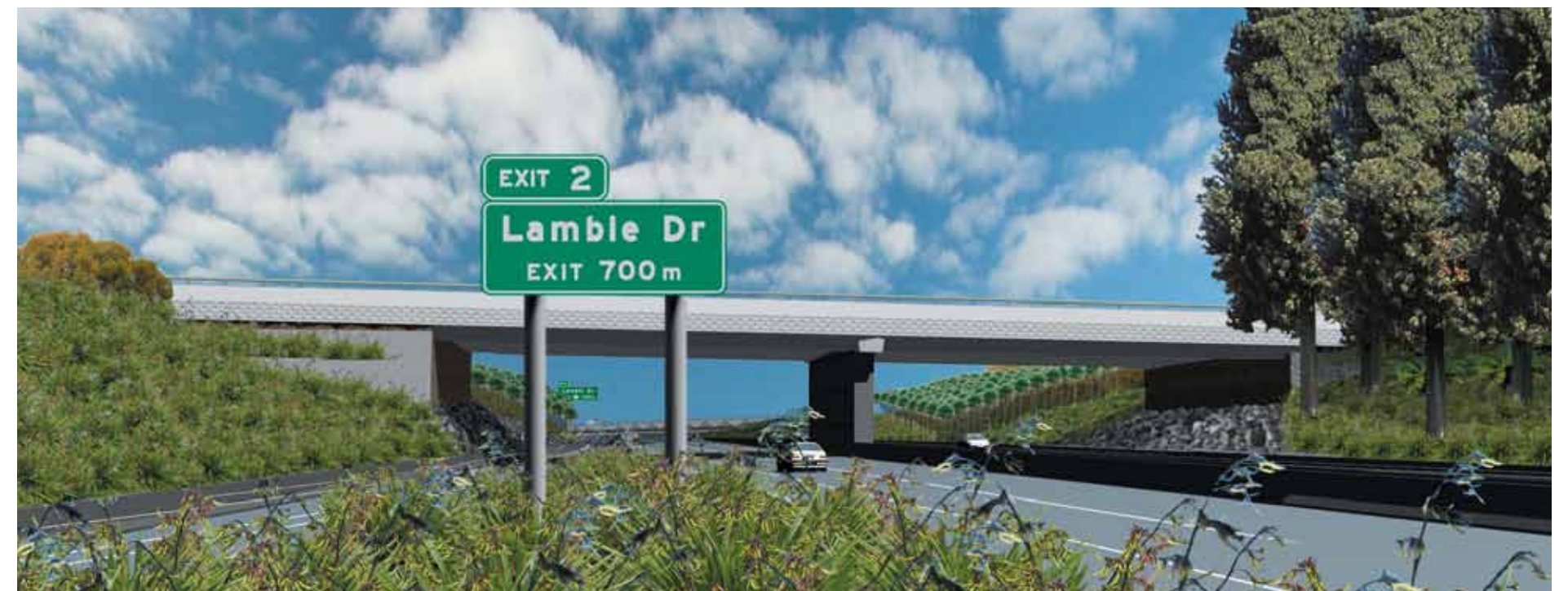

Figure 8.3 - Eastern 'Gateway' bridge - Great South Road.

Note: Final design of barriers subject to change during detailed design phase.

8.1 Bridges, Retaining Walls, Abutments, Gantries

Bridges, retaining walls, abutments, gantries and other related infrastructure play an important role in the physical function of the motorway. Typically these are treated in a utilitarian manner but with some simple treatments in form, colour, texture and other design devices, these elements can become a visually exciting and memorable part of the motorway journey, the surrounding area and part of the overall integrated art approach to the design of the infrastructure without significantly adding to the cost of the development.

The overall objective for walls and other vertical built form elements for this project, from an urban and landscape design perspective, is to provide effective control of slopes and batters and ensure smooth transition from horizontal to vertical surfaces in an aesthetically pleasing manner.

A series of walls and hard surfaces; including retaining walls, spill through abutments and noise walls are features of the design for this project that contribute to the cultural and geological story that this design process has revealed.

The design premise behind the treatment of walls and hard surfaces below natural ground are characterised by the region's geology such as the striations of historical layering of marine and alluvial sediments and basalt from the lava field.

Walls and hard surfaces above natural ground level are characterised by cultural references. This is realised by the abstraction of Pacifica geometry that has also been adopted by the earthworks and plantings in the civic area between Great South Road and Lambie Drive.

Additionally, noise attenuation walls are characterised by another historical element that has given rise to the naming of Manukau: He Manu Kau noa iho (there were only birds). The abstraction of forest birds flying between pockets of forest forms the basis for their design.

These ideas have been interpreted in different ways as follows:

- Exposed aggregate surface treatment to selected panels on retaining walls at either end of the Redoubt Flyover to form large scale Pacifica geometry patterns;

- Retaining walls and side walls at the SH20 under SH1 underpass are heavily rusticated with the base of the walls being more heavily textured than the top;
- Great South Road bridge is characterised by vertical walls at the half spill through abutments and returns. These are heavily rusticated to provide a sense of entering an underground lava tube. The central blade wall is also clad in rusticated panels to reinforce this notion;
- All spill through abutments under bridges over SH20 are lined with loose quarried basalt rock to provide a rusticated texture and a sense of movement like the flow of lava. The abutments are splayed outwards at the base to integrate with the Pacifica geometry; and
- Timber panel noise attenuation walls with abstracted bird flight imagery applied.

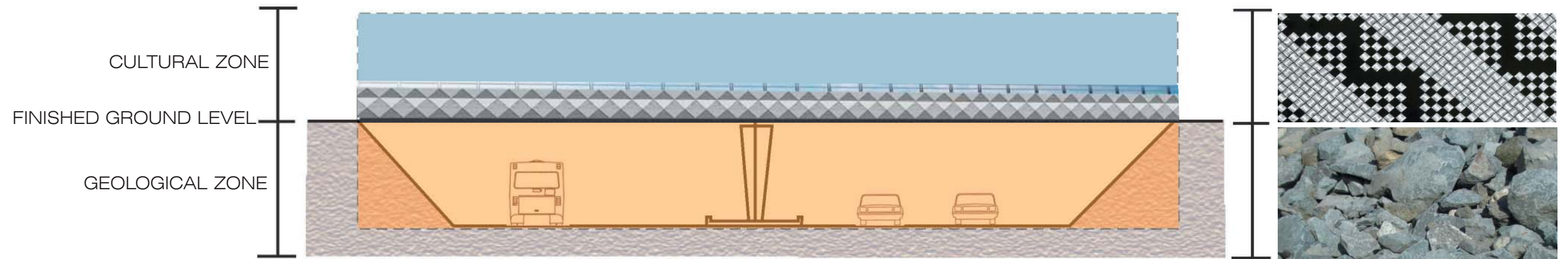

Figure 8.4 - Bridge surface treatments to infrastructure concept with geological and cultural theming

8.2 Gantries

Gantries will remain as standard tubular systems to integrate with signage gantries in adjacent sections of SH20 and SH1.

8.3 Safety Barriers

Safety Barriers in the central medians are standard form and finish as specified without any form of embellishment such as formed relief as proposed elsewhere on bridges.

8.4 Spill Through Abutments

All spill through abutments under bridges are comprised of local quarried volcanic rock and are angled to splay out. This rock will be fixed in position with mortar.



Figure 8.5 - Volcanic Rock

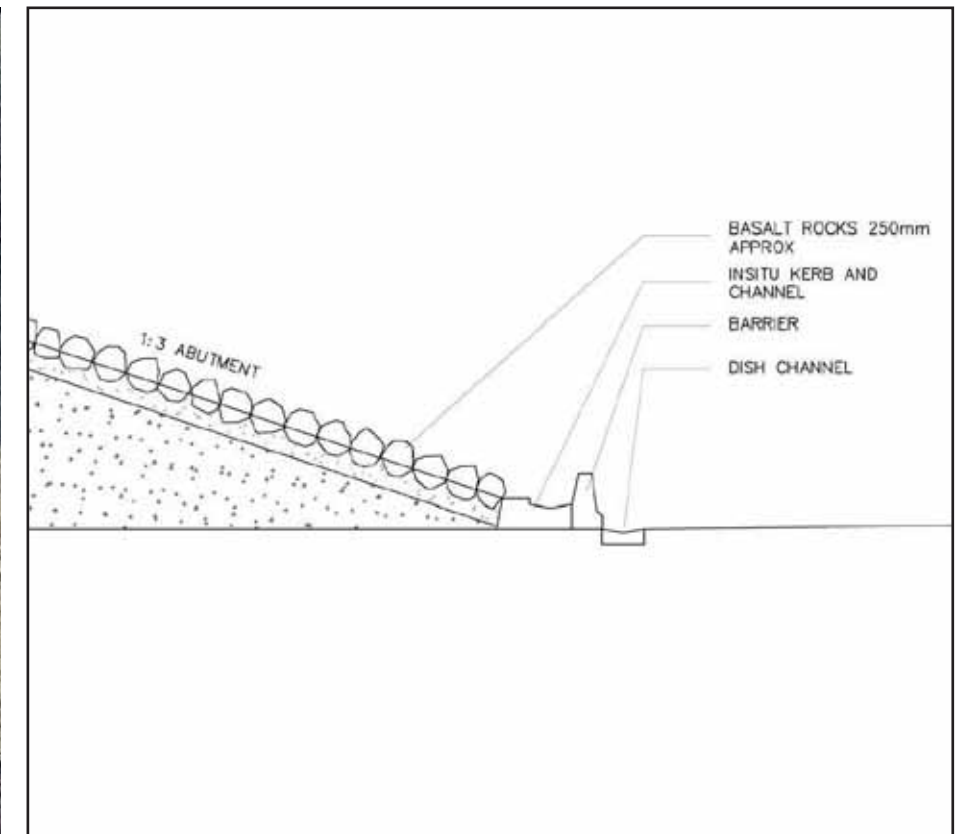

Figure 8.6 - Spill Through Abutment.

8.5 Retaining Walls

Retaining walls at Great South Road Bridge and SH20 under SH1 will be pre-fabricated panels with geologic rusticated finishes.

Retaining walls either end of the Redoubt Flyover and the Church of the Latter Day Saints will be planted with self adhering climbing plants such as Ficus pumila.



Figure 8.7 - Ficus pumila



Figure 8.8 - Ficus pumila

8.6 Acoustic Barrier Walls

The noise walls provide an acoustic buffer from motorway noise, enhance motorway visual amenity and contribute to the “sense of place” of this area.

Imagery on the walls is an abstract representation of native forest birds flying between pockets of forest along the Manukau Extension ecological corridor.

Historical lowland forests in Manukau once supported a rich population of birds that relied upon the forests for food and shelter. The motorway project, with its extensively planted areas and its potential to provide an ecological corridor, highlights the need for an awareness of the fauna that relies on it for survival and the hope of a return to a healthy habitat.

The walls are designed to be viewed at a speed of 100km/hr, and are arranged in a continuous pattern of ‘frames’, constructing the allusion of a bird flapping its wings in time lapse motion as it travels along the motorway alignment. When viewed by the motorist, the abstracted wing beats give a sense of movement and speed of travel.

It is anticipated that the walls will dive in and out of planted areas, giving the impression of birds moving between pockets of forest. Designed to join seamlessly, the walls will give the impression of continuous flight.

It is anticipated that the walls will be visible only temporarily, until vegetation can grow up to screen them, as regardless of the high level of visual amenity anticipated, planting is a preferred aesthetic to walls.

The walls, constructed from timber prefabricated panels, will follow the contours with support structure concealed behind. Where amenity is required both sides, a double sided panel to conceal the support structure will be considered. Detailing will be applied to the surface of the panels with screen printing techniques or stencilling.

Note: Concept only. Final design subject to change in detailed design phase.

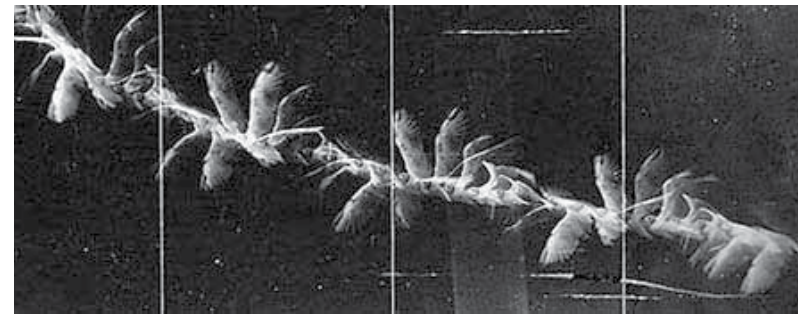

Figure 8.9 - Photographic representation of a bird in flight
(Étienne-Jules Marey, Bird Flight)

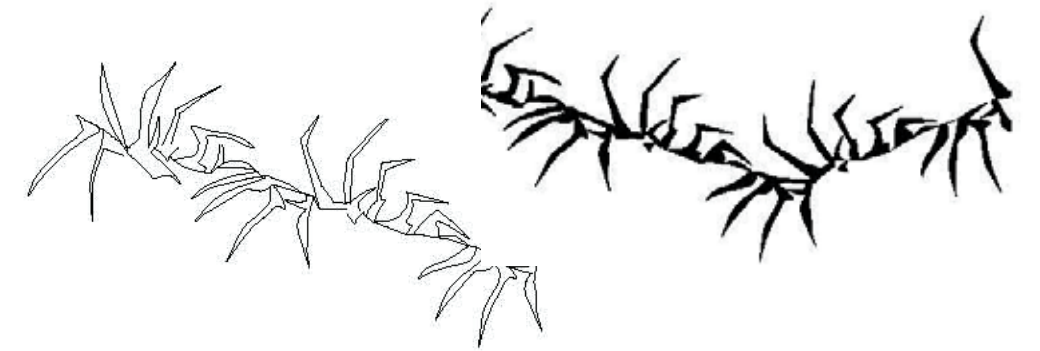

Figure 8.10 - Abstractions of bird wing beats

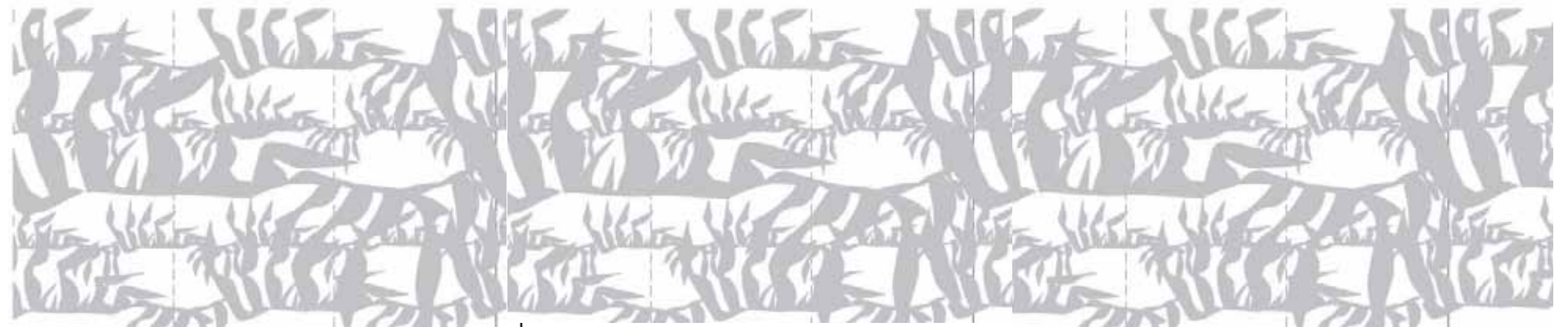

Figure 8.11 - Acoustic barrier wall design

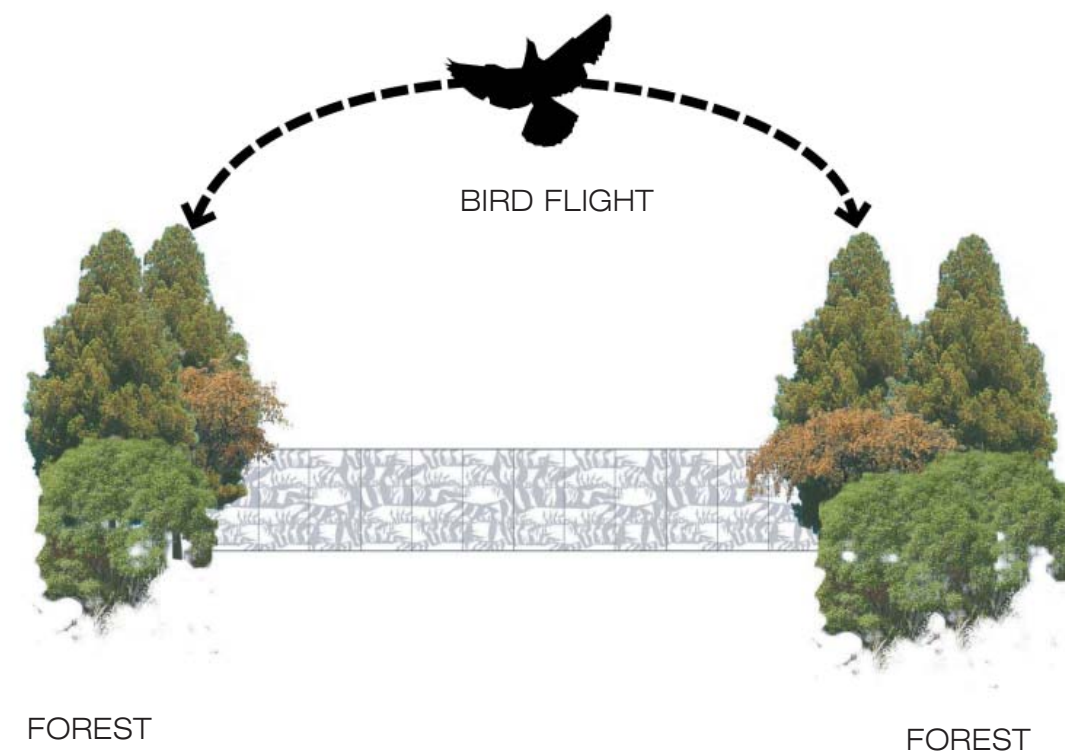

Figure 8.12 - Design approach to acoustic barrier walls

8.7 Bridges

Bridges are the single most visually important built element of this motorway sequence and offer the potential to provide a highly memorable visual experience.

They must not only work at the scale of the motorway but also from the perspective of motorists, cyclists and pedestrians who cross above or below the motorway and from those on neighbouring properties.

While recognising the constraints of budget and engineering considerations, it is important to ensure the bridges on this motorway are well mannered and as visually stimulating as possible.

8.8 Bridge Sequences and Descriptions

There are 6 new bridges proposed for this project in fairly quick succession. It is important to create an 'Entry' and 'Exit' sequence in each direction as well as a gateway element at the interchange. The Great South Road and Plunket Avenue bridges offer this opportunity along with the Redoubt Flyover.

Figure 8.13 - Bridge location and character

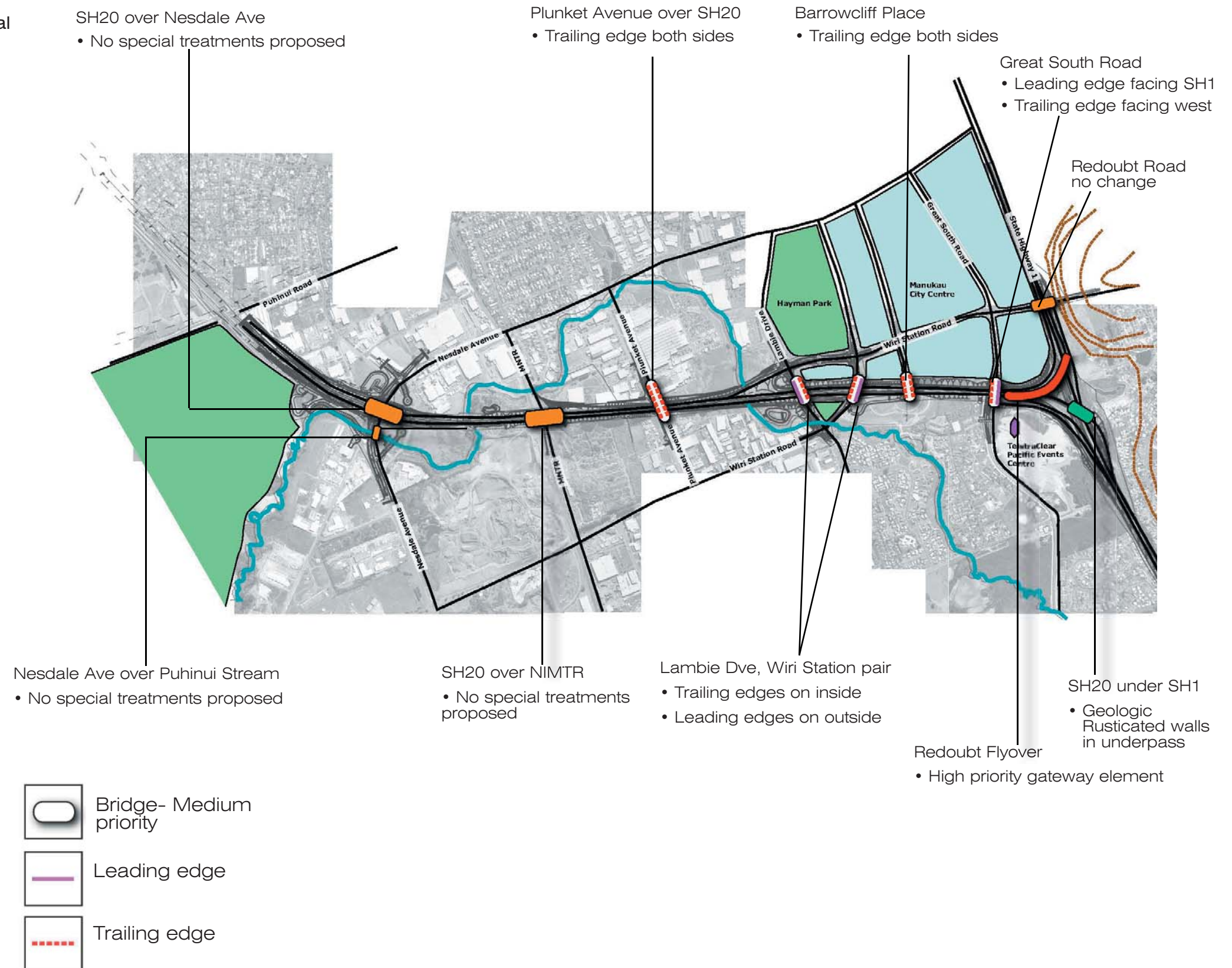

8.8 Colour and Graffiti Protection Systems

Colour is a vital part of the vibrant Pacific culture that characterises Manukau City.

While the majority of bridge components are standard concrete finishes, with any patterning provided by the use of textured formwork in the pre-cast moulds, accent colours are proposed for elements of the bridges.

Red is chosen, being a clean and bright colour and representative of Pacific colours occurring naturally (flame tree) and in Pacific art and textiles.

Red is used for applied decoration on the steel flats forming the balustrade to the 'decorated' barriers to Barrowcliffe Place and Great South Road bridges.

This accent colour provides an emphasis and meaning to the bridges in a cost effective manner.

Transit's requirement is for a 25-year life to first maintenance. This can be achieved either by applying an epoxy paint coating over suitably prepared hot dip galvanised steel, or over evenly coated zinc spray to 250 micron / 1500g/sqm. To avoid touch up of galvanising or paint system in situ, the balustrade would be fabricated in sections matching the concrete barriers, painted off-site and bolted in place.

Note:

The intention in the tender bid was to use yellow to highlight the crosshead beams, which form the centrepiece of the predominantly two span bridges, and to pick out the abutment beams. However, as Transit NZ policy is to avoid applied finishes to concrete structures, this colour emphasis will be deleted. The alternative of integral colour in the concrete will not give the intensity required; therefore, colour has been deleted from the concrete elements.

Transit do however require an applied coating in the form of anti graffiti measures. These may be either sacrificial, in the form of siloxane-based treatment, or a clear 'permanent' anti-graffiti coating based on 2-pot acrylic-urethane technology. With the latter system, we propose a matt or satin finish rather than gloss.

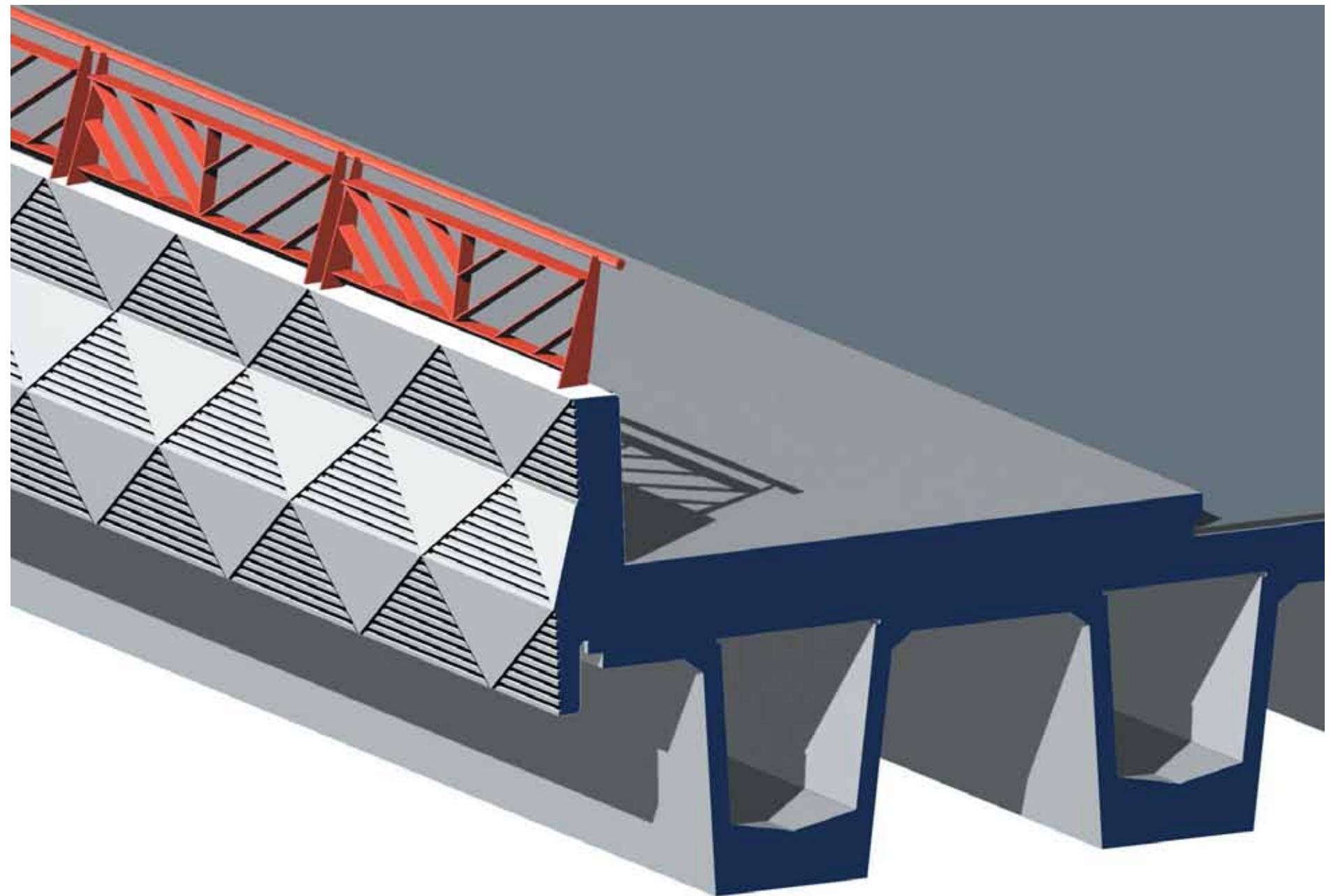
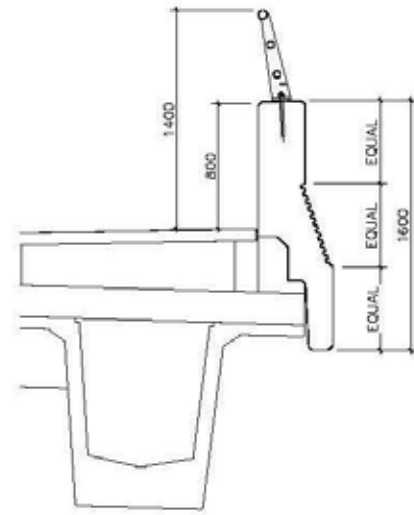

Figure 8.14 - Coloured railings on Barrowcliffe Place Bridge with trailing edge barrier

TRAILING EDGE SCHEDULE

- Decorative:**
 Great South Road - West
 Barrowcliffe Place - Both
- Standard:**
 Wiri Station Road - West
 Lambie Drive - East
 Plunket Avenue - Both



SECTION

TRAILING

LEADING

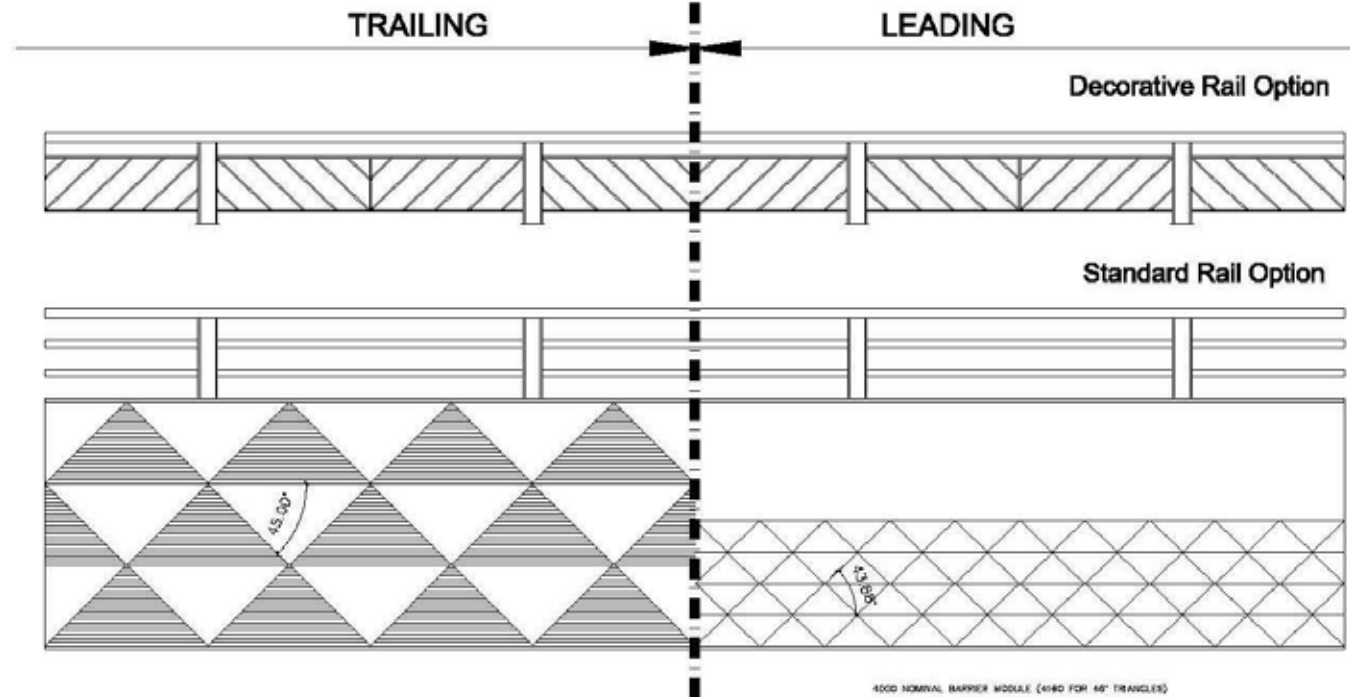

ELEVATION

ELEVATION

STANDARD BARRIER MODULES (4160 FOR 45° TRIANGLES)

ELEVATION

LEADING EDGE SCHEDULE

- Decorative:**
 Great South Road - East
- Standard:**
 Wiri Station Road - East
 Lambie Drive - West
 SH1 over SH20 - Both

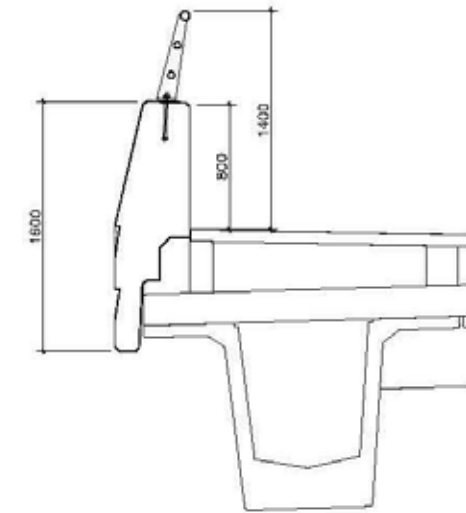

SECTION

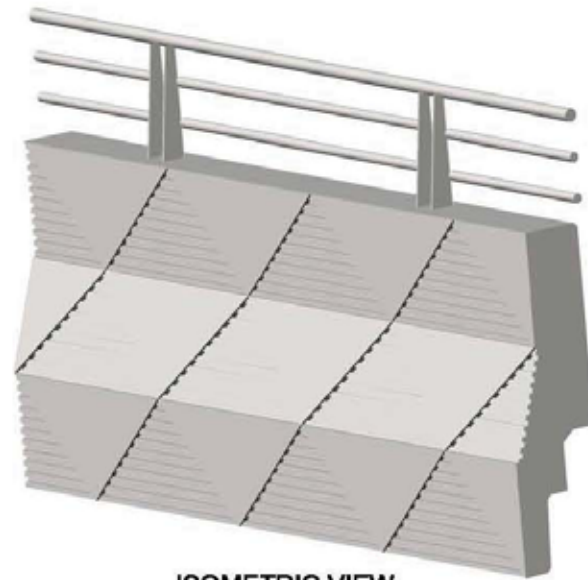

ISOMETRIC VIEW

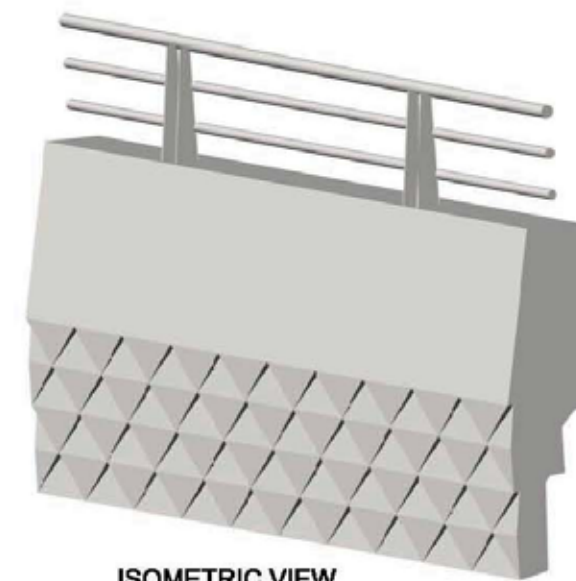

ISOMETRIC VIEW

205047.03
 SK-001 Rev A 21-12-08

SH20 MANUKAU BRIDGES - LEADING AND TRAILING EDGE BARRIERS

Figure 8.15 - Leading and trailing edge barrier and hand rail set out drawings



Figure 8.16 - Plunket Avenue bridge - Western entry

8.9 Plunket Avenue Bridge

- The only multi-span bridge crossing SH20
- Inclined both sides – the only ‘up and over’ bridge
- Low key design approach, befitting industrial surroundings
- Length and lightness of the bridge would be visually enhanced by use of single “piloti” at 27m centres. The current triple pier configuration is less successful in this respect.
- Uses ‘plain’ version of TL4 barrier profile
- Although this is an ‘entry’ bridge, its light and elegant form suggests the use of the standard ‘trailing edge’ barriers to both sides



Bridge location

8.10 Lambie Drive & Wiri Station Road Bridges

- Pair, or set of bridges, embracing tail end of Hayman Park
- Denote start of more intensive landscape treatment to Manukau City Centre section of SH20
- Paired 'leading and trailing edge' approach, each similar to Great South Road bridge treatment
- Plain concrete finishes with subtle triangular pattern on trailing edge barrier on inside with 'standard' version of steel handrail to barrier
- Leading edges on outside edges with full height concrete barriers featuring folded triangular formwork and finishes to realise Pacifica geometry



Figure 8.17 - Lambie Drive eastbound - leading edge



Figure 8.18 - Lambie Drive westbound - trailing edge



Bridge location



Figure 8.19 - Wiri Station Road westbound - leading edge



Figure 8.20 - Wiri Station Road eastbound - trailing edge



Figure 8.21 - The Lambie Drive / Wiri Station Road pair of bridges, eastbound view



Figure 8.22 - Wiri Station Road bridge, eastbound view. Barrowcliffe Place bridge beyond



Bridge location



Figure 8.23 - Barrowcliffe Place bridge, eastbound view, showing triangular Pacifica motif and painted decorative railing to the barriers, in situ concrete tapered 'W' pier and volcanic rock lined spill through abutments. Great South Road bridge beyond

8.11 Barrowcliffe Place Bridge

- Connecting element between residential areas and Manukau Civic Centre – more of a showpiece bridge due to prominence of location
- Minor bridge from a traffic perspective will read 'lighter' than others
- Trailing edge barrier with decorated finishes applied to both sides of this visually important bridge
- Decorative handrail option provides a more tactile, pedestrian-friendly detail while enhancing the inscribed larger scale design on the concrete section of the barrier. Steel handrail painted red
- Strong form of the 'W'-shaped tapered in situ concrete pier is heightened by its use of board-marked finish



Bridge location



Figure 8.24 - Great South Road bridge, westbound view - the eastern entry portal to State Highway 20. Facetted Leading Edge barrier, heavily rusticated finish to both MSE abutment walls and central pier precast concrete cladding panels are the main features of this bridge

8.12 Great South Road Bridge

- Main entry to Manukau Civic Centre from SH1 interchange
- Extend 'leading and trailing edge' approach used on other entry bridges (the Lambie Drive/Wiri Station Road pair)
- To create greater sense of being drawn into a new space, provide 'venturi effect' by using rusticated abutment walls, with abstracted geologic texture
- The sombre colouration of the panels on the abutment walls and central pier is contrasted with the plain finish concrete of the crosshead beams, bridge beams and barriers

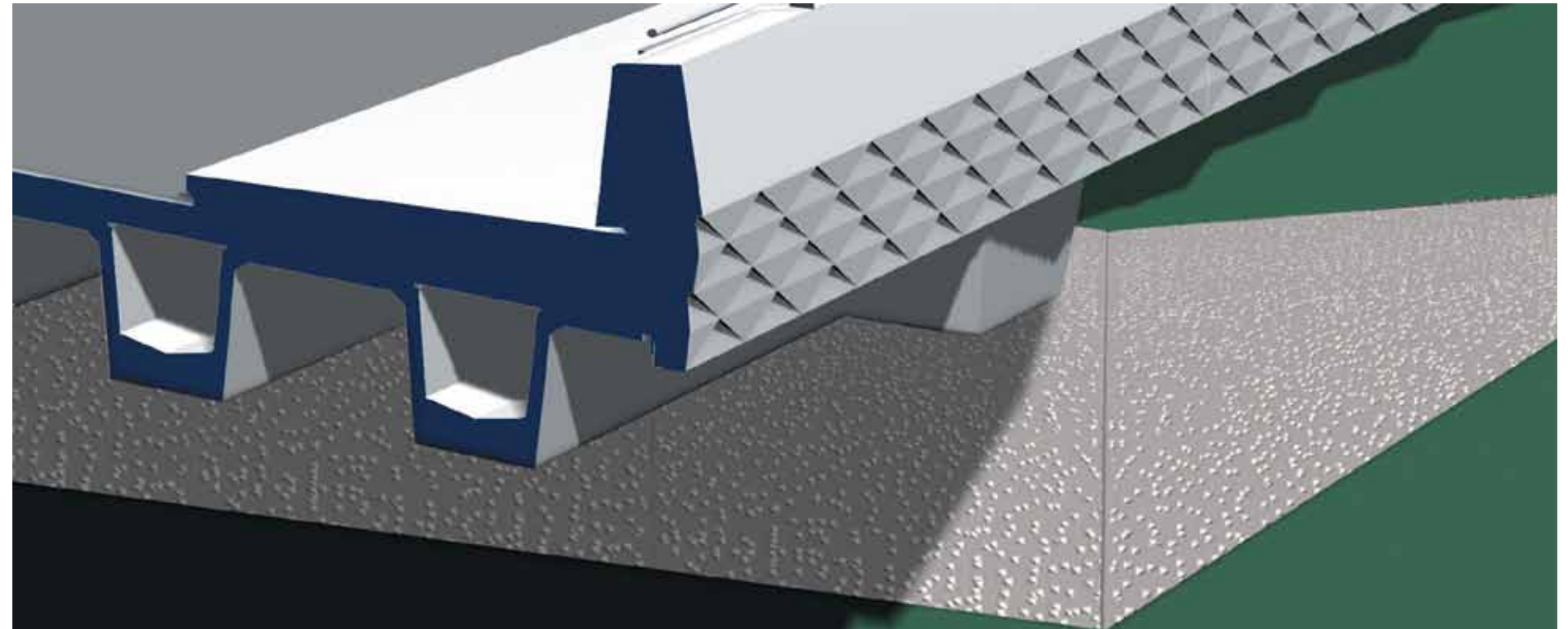

Figure 8.25 - Great South Road leading edge barrier showing geologic rusticated split abutment



Bridge location

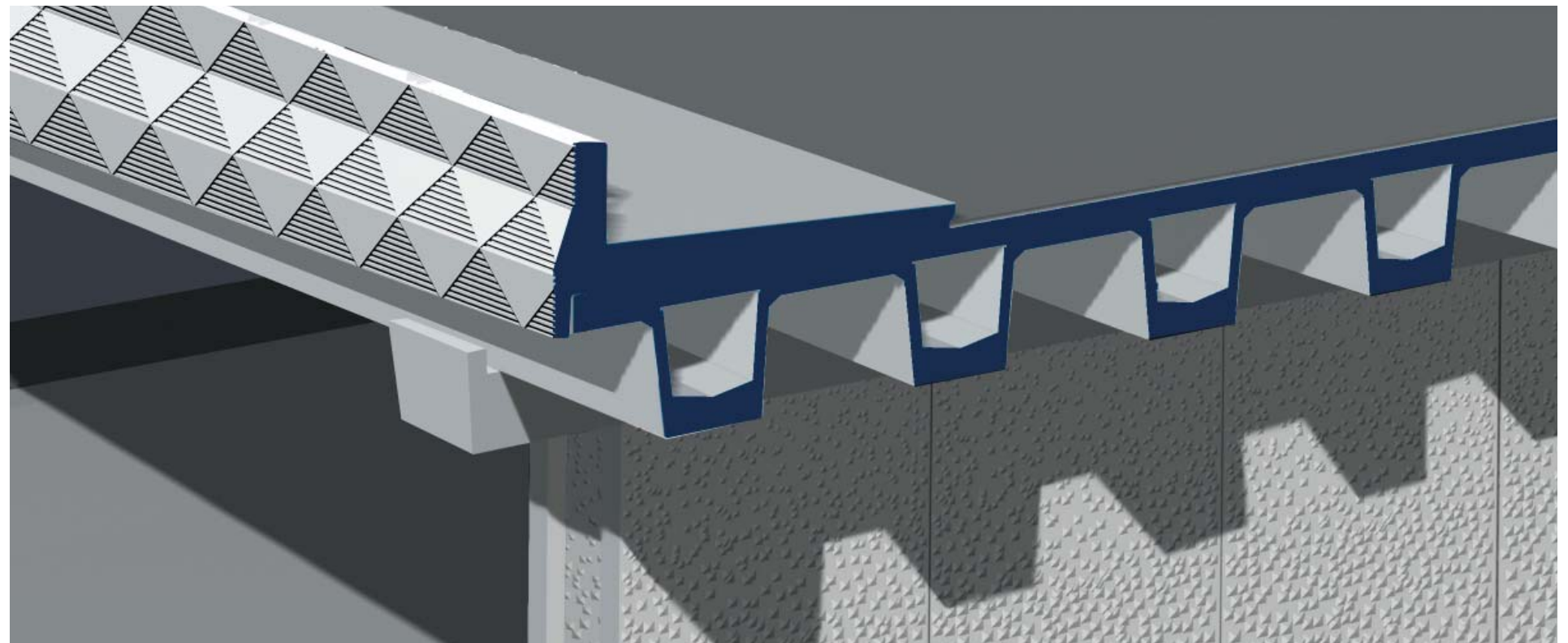

Figure 8.26 - Great South Road trailing edge barrier showing geologic rusticated central pier



Figure 8.27 - Redoubt Road Flyover viewed from State Highway 1 northbound, showing piers with splayed crosshead beams and barriers

8.13 Redoubt Road Flyover

- The significant location of the bridge, its graceful curving form and super-elevation defines this bridge a 'gateway' element of the State Highway 1 sequence and the Manukau City entrance
- Bridge curvature is emphasized with repeating modular elements enveloping the barrier
- Directional feature lighting possibilities to highlight curve and direction of flyover



Bridge location

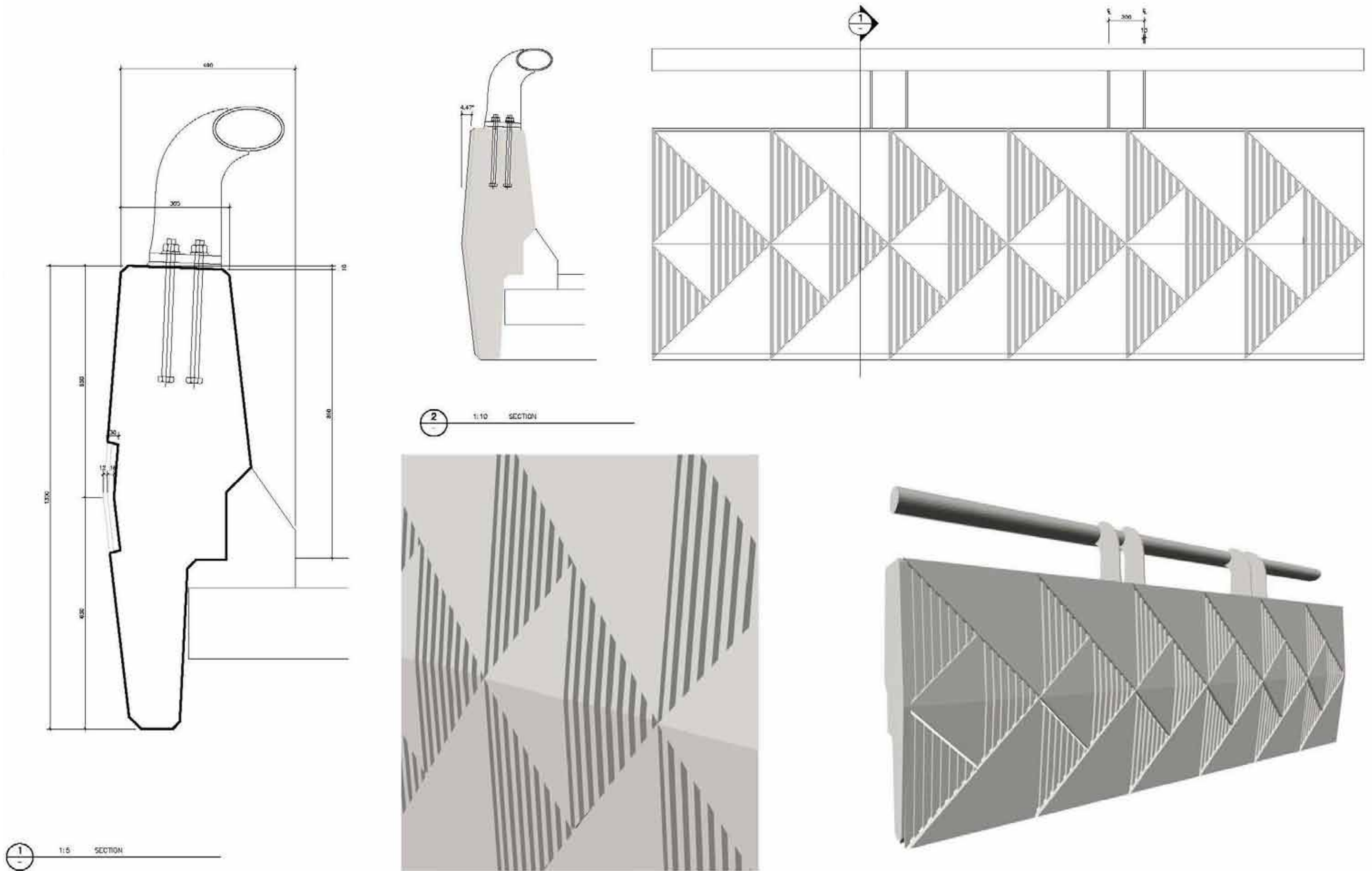

Figure 8.30 - Redoubt Road Flyover detail of barrier and hand rail.



Figure 8.31 - Redoubt Road Flyover view Southbound from State Highway 1



Figure 8.32 - Redoubt Road Flyover view Northbound from State Highway 1 approaching Manukau City interchange

8.14 SH 20 under SH1 Link

- Form of underpass represented as a 'gash' through the underlying geology
- Underpass and walls either side to be lined with pre-cast concrete panels that are heavily rusticated at the base and finely textured at the top to reinforce underlying volcanic geology



Bridge location

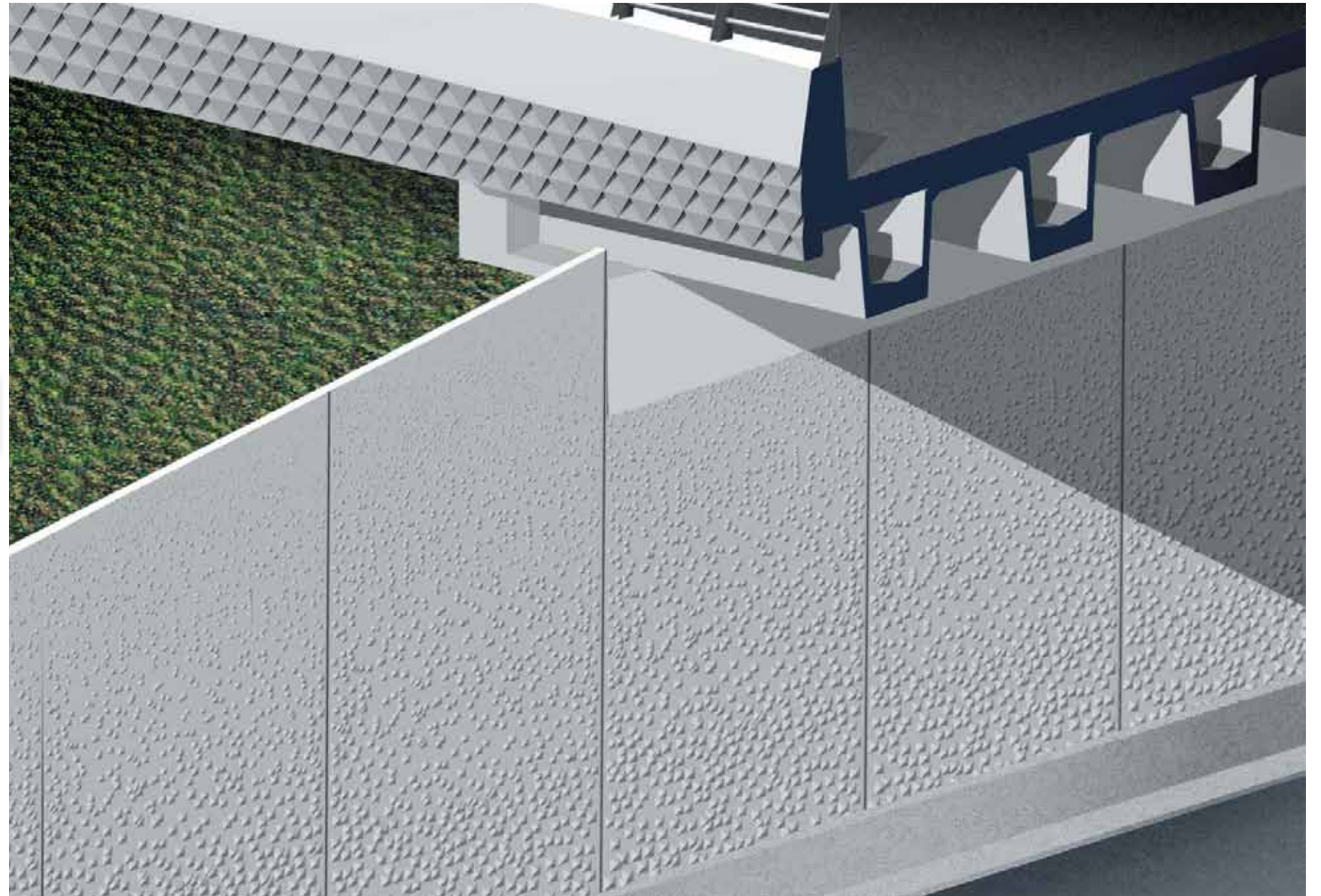

Figure 8.33 - Detail of underpass State Highway 20 under State Highway 1 (Southern Motorway)