NZTA P24:2020 Specification for Permanent Traffic Signs

February 2020

VERSION 2.1a

Specification for the design, manufacture, installation and maintenance of permanent traffic signs



Copyright information

This publication is copyright © Waka Kotahi NZ Transport Agency. Material in it may be reproduced for personal or in-house use without formal permission or charge, provided suitable acknowledgement is made to this publication and Waka Kotahi NZ Transport Agency as the source. Requests and enquiries about the reproduction of material in this publication for any other purpose should be made to:

Manager, Information
NZ Transport Agency
Private Bag 6995
Wellington 6141

The permission to reproduce material in this publication does not extend to any material for which the copyright is identified as being held by a third party. Authorisation to reproduce material belonging to a third party must be obtained from the copyright holder(s) concerned.

Disclaimer

Waka Kotahi NZ Transport Agency has endeavoured to ensure material in this document is technically accurate and reflects legal requirements. However, the document does not override governing legislation. Waka Kotahi NZ Transport Agency does not accept liability for any consequences arising from the use of this document. If the user of this document is unsure whether the material is correct, they should refer directly to the relevant legislation and contact the Transport Agency.

More information

NZ Transport Agency
Published FEBRUARY 2020

ISBN 978-1-98-856163-9 (online)

If you have further queries, call our contact centre on 0800 699 000 or write to us:

NZ Transport Agency
Private Bag 6995
Wellington 6141

This document is available on Waka Kotahi NZ Transport Agency's website at www.nzta.govt.nz

This Specification will be updated periodically to incorporate advances in technology and changes within the industry. The NZTA website should be checked to confirm the most recent edition of the specification.

RECORD OF AMENDMENTS			
Amendment Number	Subject	Effective Date	Updated by
Version 1.0	Issued for Comment	November 2019	Julian Chisnall
Version 2.1	Issued for ratification	January 2020	Julian Chisnall
Version 2.1	Ratified	February 2020	Julian Chisnall
Version 2.1a	Minor format correction	October 2020	Julian Chisnall

Table of Contents

FOREWORD.....	1
1. SCOPE.....	2
2. RELATED DOCUMENTS.....	3
3. DEFINITIONS.....	5
4. COMPLIANCE.....	8
4.1 Sign manufacturer identification.....	8
4.2 Sign installer identification.....	8
4.3 Sign manufacture.....	9
4.4 Retroreflective sheeting.....	9
4.5 Sign systems.....	11
4.5.1 Aluminium substrate sign systems.....	12
4.5.2 Support channel, extrusions, brackets, fittings & fixtures.....	12
4.6 Street name signs.....	12
4.6.1 Aluminium extrusion.....	12
4.6.2 Brackets and fittings.....	13
4.7 Sign support systems.....	13
4.7.1 Sign supports for small signs.....	13
4.7.2 Sign supports for large signs.....	14
4.8 Foundations.....	14
5. DESIGN.....	15
5.1 Sign face.....	15
5.1.1 Retroreflective design components.....	15
5.1.2 Protective overlay sheeting.....	15
5.2 Strength and rigidity.....	15
5.3 Load factors & strength reduction factors.....	17
5.4 Serviceability limits.....	18
5.5 Foundation design.....	18
5.6 Resistance to twisting.....	19
5.7 Sign support design.....	19

5.8	Impact performance for sign supports.....	20
6.	MANUFACTURING.....	22
6.1	Sign face.....	22
6.2	Retroreflectivity.....	22
6.3	Retroreflective compatibility.....	23
6.4	Sign blanks.....	25
6.4.1	Sign blank jointing.....	25
6.4.2	Aluminium sign substrate.....	26
6.4.3	Alternative sign substrates.....	26
6.5	Sign stiffening.....	26
6.5.1	Stiffening of aluminium substrates.....	26
6.5.2	Alternative sign substrate stiffening & fixing components.....	27
6.6	Preparation and painting.....	27
7.	SIGN INSTALLATION.....	28
7.1	Packing handling and transportation.....	28
7.2	Principle of retroreflectivity.....	28
7.3	Positioning.....	29
7.4	Orientation.....	30
7.5	Sign support selection.....	34
7.6	Sign supports & impact requirements.....	34
7.7	Foundations.....	36
7.8	Sign assembly.....	36
8.	INSPECTION SURVEYS.....	37
8.1	Daytime surveys.....	37
8.2	Night time surveys.....	38
9.	MAINTENANCE AND CLEANING.....	39
9.1	Cleaning substances.....	39
9.2	Recognising sign face sheeting components.....	40
9.3	Cleaning protective overlays.....	41
9.4	Maintenance of sign substrates, supports and foundations.....	43
9.5	Maintenance performance degradation/sign life.....	43
10.	SIGN REPLACEMENT.....	44
10.1	Minimum retroreflective performance.....	44
10.2	Apparent sign over-brightness.....	45
10.3	Temporary sign covering.....	45

APPENDICES

Appendix A	Stiffening of aluminium panels for permanent warning and & regulatory signage	46
Appendix B	Sign Support Selection Charts for Small Signs.....	48
Appendix C	Foundation Selection Tables for Small Signs.....	58
Appendix D	Worked Sample Using Sign Support & Foundation Selection Charts in Appendices B & C.....	69
Appendix E	Alternative Substrate & Componentry for Traffic Sign Systems...	71
Appendix F	NZ Transport Agency Accepted Products and Systems	74

This page is blank on purpose

Foreword

This Specification is prepared by Technical Services, Operational Planning, Policy and Performance, Waka Kotahi NZ Transport Agency⁽¹⁾, with technical input from the Road Safety Manufacturer's Association (RSMA).

The objective of this specification is to set out performance requirements for traffic sign manufacturers wishing to design and manufacture and contractors wishing to install and maintain permanent traffic signs in New Zealand.

The main changes that have been incorporated into this Specification include:

- Recognition of the publication of the revised Standard AS/NZS 1906.1:2017 – *Retroreflective materials and devices for road traffic control purposes: Part 1 Retroreflective sheeting*.
- Introduction of NZTA M25:2019 *Retroreflective sheeting for traffic signs and vehicle number plates* – Specification.
- The merging of the previous Transit New Zealand P24 *Performance based specification for traffic signs* and P24 Notes.
- Incorporation of the Road Safety Manufacturers Association (RSMA) “RSMA Compliance standard for traffic signs” 2008

Readers of this specification must also read and be aware of the Traffic Control Devices (TCD) Manual, Part 1 specifically, but not limited to, Section 7 Installation and Section 8 Retroreflectivity and Illumination.

Waka Kotahi NZ Transport Agency acknowledges the contribution to this document and its predecessors through the continued efforts of the Road Safety Manufacturers Association (RSMA).

¹ Here-after referred to as the Transport Agency

1. SCOPE

This specification sets out the performance requirements for the design, manufacture, installation and maintenance of permanent traffic signs used on the New Zealand roading network. It builds on the legal requirements for traffic signs in New Zealand covered by the Traffic Control Devices (TCD) Rule and the TCD Manual.

Performance requirements are specified with respect to:

- (a) Retroreflective performance
- (b) Colour and daytime Luminance
- (c) Sign manufacture
- (d) Sign installation
- (e) Maintenance and cleaning
- (f) Sign durability
- (g) Sign warranty
- (h) Substrate and sign manufacture - Strength and Rigidity
- (i) Safety

This specification does not cover the following types of signs:

- (i) Flexible sign faces
- (ii) Internally illuminated signs
- (iii) Variable message signs
- (iv) Temporary warning signs covered by CoPTTM

2. RELATED DOCUMENTS

NOTE: Readers should comply with the most current publication of the specification being referenced.

AASHTO LTS-4-M	Standard Specifications for Structural Supports for Highway Signs, Luminaires and Traffic Signals, 4 th Edition
AS/NZS 1163	Cold-formed structural steel hollow sections
AS 1170.4	Part 4 Earthquake actions in Australia
AS/NZS 1170	Structural design actions Part 0: General principles,
AS/NZS 1170.1	Structural design actions Part 1: Permanent, imposed and other actions
AS/NZS 1170.2	Structural design actions Part 2: Wind actions
AS/NZS 1170.3	Structural design actions Part 3: Snow and ice actions Snow and ice actions
AS/NZS 1554.1	Part 1 Structural steel welding - Part 1: Welding of steel structures
AS/NZS 1734	Aluminium and aluminium alloys – Flat sheet, coiled sheet and plate.
AS/NZS 1866	Aluminium and aluminium alloys – Extruded rod, bar, solid and hollow shapes
AS 1906.1	Retroreflective materials and devices for road traffic control purposes Part 1: Retroreflective sheeting
AS/NZS 1906.3	Retroreflective materials and devices for road traffic control purposes Part 3: Raised pavement markers (retroreflective and non-retroreflective)
AS/NZS 2980	Qualification for Welders for Fusion of Steels
CoPTTM	Code of Practice for Temporary Traffic Management, Traffic Control Devices Manual, Part 8
NZS 3460	Chemical preservation of round and sawn timber
NZS 3631	NZ Timber Grading Rules
NZS 4203	Code of practice for general structural design and design loadings for buildings
AS/NZS 3678	Structural steel – Hot-rolled plates, floor plates and slabs
AS/NZS 3679.1	Structural steel – Hot-rolled bars and sections
AS/NZS 3845.2	Road safety barrier systems and devices

AS/NZS 4680	Hot-dip galvanised (zinc) coatings on fabricated ferrous articles
AS/NZS 4792	Hot-dip galvanised (zinc) coatings on ferrous hollow sections, applied by a continuous or specialized process
NZBC – B1/VM4	New Zealand Building Code
NZS 1170.5	Part 5 Earthquake action – New Zealand
Austrroads Part 6	Austrroads Guide to Road Design Part 6: Roadside Design, Safety and Barriers
BS 8442	Miscellaneous road traffic signs and devices - Requirements and test methods
BS 381C	Specification for colours for identification, coding and special purposes
MASH	Manual for Assessing Safety Hardware - AASHTO
NZTA M12	Raised Pavement Markers Specification
NZTA M14	Specification for Edge Marker Posts
TNZ M23	Specification for Road Safety Hardware Systems
NZTA M25	Retroreflective sheeting for traffic signs and vehicle number plates – Specification
Traffic Control Devices Manual	Includes MoTSaM Parts 1 and 2

3. DEFINITIONS

- **Breakaway sign support**

A breakaway sign support refers to a support system that is designed to safely fracture or separate (at or near ground level) when impacted by a vehicle, thereby minimising injury to the occupants of the vehicle and damage to the vehicle.

- **Coefficient of Luminous Intensity (CIL)**

CIL: A sheeting's retroreflective performance or brightness. It is often abbreviated to R sub A (R_A)

- **Foundation**

That part of a sign support system, usually below the ground, that transfers and distributes the weight and stability of the sign system into the ground

- **Frangible sign support**

A sign support that is designed to yield or break away when impacted by a vehicle

- **Hinge**

The weakened section of a breakaway sign support designed to allow the post to rotate when impacted by a vehicle

- **Intended life**

The "intended life" is the period of time a sign shall meet the performance requirements specified in order to be used for budgeting and replacement forecast purposes. This includes the effects of normal environmental degradation expected at any given site, but excludes accidental or wilful damage and the effects of extreme weather events.

- **Large Traffic Sign**

Roadside sign with a sign area greater than 4.7m²

- **Matched component system**

This describes a number of individually accepted components that when assembled together are proven to adjoin successfully in order to collectively achieve a prescribed result.

- **May**

Term used to indicate something that is optional and may be considered for use

- **Must**

Term used to indicate something that is mandatory or required by law

- **RCA**

Road Controlling Authority

- **Roadside (Clear area)**

The desirable unobstructed roadside area available for recovery of errant vehicles that have left the road

- **Shall**

Term used to indicate something that is mandatory or required by law

- **Should**

Term used to indicate a recommendation based on industry best practice

- **Sign face**

Refers to the retroreflective sheeting and any overlay film or colouring used in the make-up of the sign legend and background

- **Sign face warranty**

This is a period of time that a sign manufacturer will warranty the retroreflective performance of a sign stating that it will be no less than a specified minimum brightness (R_A) at the end of a stated number of years. It is typically stated as a level of performance that will be no less than a specified per cent of the new rated performance after a stated number of years.

- **Sign installation**

In this specification sign installation shall be interpreted as the “sign system” fully installed including attachments to the support structure, the foundation, positioning and correct orientation.

- **Sign Specifier**

The person or organisation who is responsible for selecting the appropriate sign performance or engineering considerations that any sign must comply with such as but not limited to a Road Controlling Authority, Engineering Consultant, Road Maintenance Contractor or person who has ultimate responsibility for the sign and its installation.

- **Sign Stiffening (Support channel)**

Sign stiffening is a component of the sign systems, matched components and describes the aluminium profiles mechanically attached to the rear of the sign substrate to provide strength and rigidity. The profiles also provide for the attachment of brackets between the sign and sign supports.

- **Sign Support**

Sign support is a general term used to describe any method used to support a sign in an appropriate position relative to the road including but not limited to use of a post, pole, overhead or cantilever gantry and attachment to an overhead structure⁽²⁾.

² Hereafter although the term sign support may be substituted by any of the alternatives mentioned in this definition each constitutes a specific type of sign support system

- **Sign system**

In this specification “sign system” shall be interpreted as including all the components that make up a sign, including sign face, sign substrate panel, stiffening and attachment brackets, fittings and fastenings.

- **Small Traffic Sign**

Roadside sign with a sign area less than or equal to 4.7m²

- **Specification**

In this standard the word “Specification” shall be interpreted as referring to the NZTA P/24 *Specification for the Design, Manufacture, Installation and Maintenance of Permanent Traffic Signs*

- **Standard**

In this specification the word “Standard” shall be interpreted as a Transport Agency approved national or international document that has been published by a recognised Standards organisation being used to provide a means of compliance with this specification. Standards must be identified by their Standards organisation and number; e.g. AS/NZS 1906.3.

- **Suitable for purpose (Suitability)**

A statement of overall daytime appearance and night time retroreflective performance referred to as being *Suitable for Purpose* is not a finite measurement but recognises that the degree of day and night visibility is deemed to be sufficient for a driver to view a sign and act in a safe manner, relative to the signs purpose.

For signs where there is a degree of indecision as to the signs *suitability for purpose* based on night time retroreflectivity (R_n), the sign will be measured, typically using a hand held retroreflectometer, to ascertain finite performance for comparison with a specified minimum performance.

- **Ultimate Limit State (ULS)**

ULS, as defined in AS/NZS 1170

- **Yielding sign support**

A yielding **sign** support refers to a support system that is designed to remain in one piece and bend at the base upon vehicle impact. The anchor portion remains in the ground and the upper assembly passes under the vehicle thereby minimising injury to the occupants of the vehicle and damage to the vehicle.

4. COMPLIANCE

All components used in the manufacture and installation of signs must be able to prove compliance with this specification based on a certificate issued by an independent, professional, Transport Agency approved, testing establishment able to prove competence in the relevant subject.

The back of the sign panel must include:

4.1 Sign Manufacturer Identification:

The back of the sign panel must include a permanent non-retroreflective identification sticker that includes the manufacturer’s name with month and year of manufacture. Additional information on the label or notated in an appropriate position using an engraving, etching or similar tool shall enable the sign manufacturer to trace the retroreflective sheeting manufacturer's information such as class of sheeting and sheeting batch number that are required in support of any warranty requirement.

Identification marking size shall be a maximum of 8.0cm x 12.0cm (96cm²) and shall be of the same durability as the intended life of the sign.



4.2 Sign Installer Identification:

The back of the sign panel must include a permanent non-retroreflective *Confirmation of Compliance* sticker or label plate no more than 6.0cm x 10.0cm (60cm²) that confirms compliance for the “*Sign Installation*” with NZTA P24 and NZTA M25 reference. This sticker or label plate must be durable for the life of the sign and must identify the installation contractor who must make this confirmation.

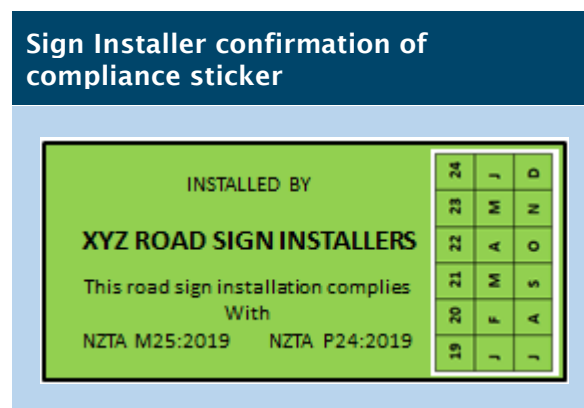

4.3 Sign manufacture:

Permanent Traffic signs are manufactured from a number of matched components that, when tested individually and tested assembled, must successfully meet the requirements of NZTA P24.

Use of any individual component or combination of individual components already accepted by the Transport Agency does not qualify as acceptance of the sign system because it is the combination of **all components** when assembled as a **matched component system** for installation onto sign supports that must be accepted.

The Transport Agency encourages innovation and recognises that, now and in the future, sign substrates and system components other than aluminium may meet the requirements of NZTA P24. In all cases the sign system must include matched system components that will be required to confirm compliance with P24 both individually and as a system to gain Transport Agency acceptance. The process is detailed in Clause 4.5.

Prior to use or adoption, any new or alternative component, product, methodology or professional opinion must be accepted in advance by the Transport Agency, and confirmed by addition to Appendix F before being introduced for use on New Zealand roads. This confirmation must include supporting test data provided by a Transport Agency recognised authority.

Before being granted compliance the Transport Agency reserves the right to require the supplier to seek alternative opinions or test evidence supporting the compliance of any such submission, at the clients cost.

Where this information or any resulting conclusions are uncertain or in conflict with the submitted documentation the Transport Agency will withhold confirmation of compliance with NZTA P24 until the supplier has satisfied the Transport Agency of the fitness for purpose of the submitted material or method of construction.

After being granted such confirmation of compliance, final acceptance is valid only after confirmation by inclusion in Appendix F.

4.4 Retroreflective sheeting:

Retroreflective sheeting used in the manufacture of all signs must be compliant with:

- (i) AS/NZS 1906.1 Standard *Retroreflective materials and devices for road traffic control purposes Part 1 Retroreflective sheeting*.
- (ii) NZTA M25 *Retroreflective sheetings for traffic signs and vehicle number plates – Specification*, supported by confirmation in the New Zealand Gazette as having either *Interim Approval* or *Approved Material* status for use in New Zealand

The characteristics of the various *Classes* of retroreflective sheeting outlined herein are also defined in the AS 1906.1 Standard and in the TCD Manual Section 8. These documents however, are not responsible for determining which sheeting is most appropriate for use at any one site because of the number of variables that may exist.

The retroreflective sheeting *Class* that must be used in manufacturing a sign will typically be selected by the specifier to exhibit the most appropriate performance level relative to the signs position and size considering the entrance and observation angles created by an approaching vehicle.

A decision for the use of fluorescent coloured retroreflective sheeting may also be selected by the specifier. However the contractor should be aware of those signs or categories of signs that must be fluorescent, such as the permanent warning vulnerable road user signs and Belisha discs.

In some situations the contractor should consider recommending locations of significance to a specifying RCA where added daytime and low light visibility could be justified from accident records. This would include a curve warning sign becoming fluorescent yellow where several off-road accidents have occurred. (Refer Clause 7.3 Positioning and Clause 7.4 Orientation)

If a contract specification does not specify the retroreflective sheeting class to be used, the sign manufacturer must seek its confirmation to ensure the appropriate level of visibility for the sign is achieved. This will include any one of the following Classes.

(a) Class 100:

Brief

Least photometric performance; intended life seven years. Typically there is no sign warranty available.

Referred to as *Engineer Grade*, Class 100 can be either an enclosed lens Glass Bead technology or in some instances a Prismatic technology. Class 100 exhibits the least retroreflective performance of all the Classes. Retroreflective performance can reduce by up to 50% of new performance in seven years. Durability is seldom warranted. New prismatic versions may exhibit improved durability characteristics

(b) Class 300:

Brief

Daylight white looks silver; unique cell pattern; intended life 12 - 15 years typically supported by a ten year sign performance warranty;

The original *High Intensity*, this is an encapsulated glass bead technology that achieves an improved mid-level retroreflective performance and increased intended sign life up to 15 years. Class 300 is more robust than Class 100 technology, its performance typically being warranted to be no less than 80% of “new” performance for the first 10 years.

(c) Class 400:

Brief

Base white sheeting is clearly whiter exhibiting stronger day-time colour; intended life 15 -17 years; ten-year warranty;

Referred to as *Prismatic High Intensity*, this sheeting exhibits a higher mid-level retroreflective performance than Class 300, whilst also featuring a more positive whiteness, resulting in improved day-time sheeting colours. Prismatic technology exhibits a more robust ageing characteristic that results in a potential warranted period of no less than 80% of new performance for the first 10 years.

(d) Class 900

Brief

Wide observation angle technology performance; intended life 15 - 17 years exhibiting a twelve-year warranty;

Referred to as *Standard Wide Observation Angle* prismatic technology, this sheeting exhibits a similar mid-level retroreflective performance to Class 400 but with additional wide observation capability.

Being a prismatic technology sheeting the intended sign life can be up to 15 years with warranted period no less than 80% of new performance for the first 12 years.

(e) Class 1100

Brief

Premium wide observation angle performance; intended life 16 – 18 years with a twelve-year warranty;

This sheeting is being referred to as *Premium Wide Observation Angle* prismatic technology. This Class exhibits a higher level of retroreflective performance than Class 900. Being a prismatic technology sheeting the intended sign life can be up to 18 years with *suitability of performance* frequently exceeding this. The warranted period is no less than 80% of “new” performance for the first 12 years.

4.5 Sign Systems

Sign substrate material, stiffening and jointing extrusions, brackets, fittings, fixings and componentry used in the manufacture of permanent traffic signs shall be in accordance with the following specifications and comply with current legislation or be accepted according to the requirements outlined in Appendix E with approval notification being listed in Appendix F.

Accepted substrates must also be accepted by retroreflective sheeting manufacturers for application of their sheeting such that any durability warranties available are maintained when manufactured by the sheeting manufacturer’s approved sign manufacturer.

All sign system materials and finishes shall be compatible in order to avoid deterioration due to electrolytic action or by differential thermal expansion coefficients. Alloys and finishes containing copper, zinc or electro plating shall not be used in contact with aluminium alloys.

The Transport Agency encourages innovation but substrate and individual system components of the sign system, and the assembled *Matched Component System*, must be supported by successful test results to recognised appropriate Standards in order to meet the requirements of NZTA P24 and be accepted by the Transport Agency. Such testing must be conducted at an independent (NATA/IANZ) test facility or such other laboratory accepted by the Transport Agency. The output from such testing must include the publication of comprehensive substrate stiffener selection and spacing charts for all sign and panel sizes, for use by sign manufacturers. (Refer to Appendix F)

A sign system may use substrate, panel stiffeners, substrate joiners, paint finish or attachment bracket fixtures and fixings previously accepted by the Transport Agency but any previously accepted component must be tested as a complete assembled sign system before acceptance by the Transport Agency as a *Matched Component System* will be recognised.

Substrate materials and/or their Matched Componentry other than material compliant with Clause 4.5.1 will require Transport Agency accepted test documentation to be submitted in order to confirm acceptance with NZTA P24. (Refer to Appendix E: Alternative substrate and componentry for traffic sign systems.

4.5.1 Aluminium substrate sign systems

Transport Agency *Accepted* aluminium sign substrate must be constructed from marine grade aluminium sheet Grade 5251-H34 or equivalent compliant with AS/NZS 1734 *Aluminium and aluminium alloys- Flat sheets, coil sheet and plate*, and prepared in compliance with the retroreflective sheeting manufacturer's specification that will support any warranty available. (Refer to Appendix F)

The aluminium sheet sign blanks must be a minimum thickness of 2mm for signs up to 0.36m². Sign blanks greater than 0.36m² and up to 0.9m² must use stiffened 2mm aluminium or 2.5mm unstiffened. Above 0.9m² 2.5mm aluminium sheet thickness must be stiffened.

4.5.2 Support channel, extrusions, brackets, fittings and fixtures

Transport Agency *Accepted* channel stiffening extrusions used to form a *Matched Component System* with aluminium substrate shall be extruded from alloy 6261-T5 or equivalent as referred to in AS/NZS 1866 *Aluminium and aluminium alloys* using an accepted extrusion design. (Refer Appendix F). User of an alternative material and or extrusion design must present test results (as part of a *Matched Component System*) to the Transport Agency prior to being awarded acceptance for use with traffic sign systems in New Zealand.

Fittings shall be engineered specifically to attach to and with extrusions and all items in the matched component sign system and be manufactured from durable materials such as but not limited to stainless steel type AISI 201 or 304, cast or extruded aluminium, or steel galvanised to AS/NZS 4680 *Hot-dip galvanized (zinc) coatings on fabricated ferrous articles* after manufacture.

Fittings finished in copper, zinc or electroplated are not to be used.

4.6 Street name signs

4.6.1 Aluminium extrusions

Where a street name sign purpose designed one piece "I" section aluminium extrusion is used this must be manufactured from Aluminium alloy Grade 6106-T6 or equivalent as referred to in AS/NZS 1866.

The thickness of the web of the "I" extrusion shall be no less than 2.5mm.

The depth of the "I" extrusion shall be the measurement of the flat surface of uniform thickness available for the application of the sign background surface. This measurement is referred to as the "target/retroreflective depth" Figure 4.1.

The maximum length of a Street Name Sign shall be as per the specifications unless, for a cantilevered name sign, it shall be as per the bracket manufacturers' specifications.

Figure 4.1: Street name sign target retroreflective depth

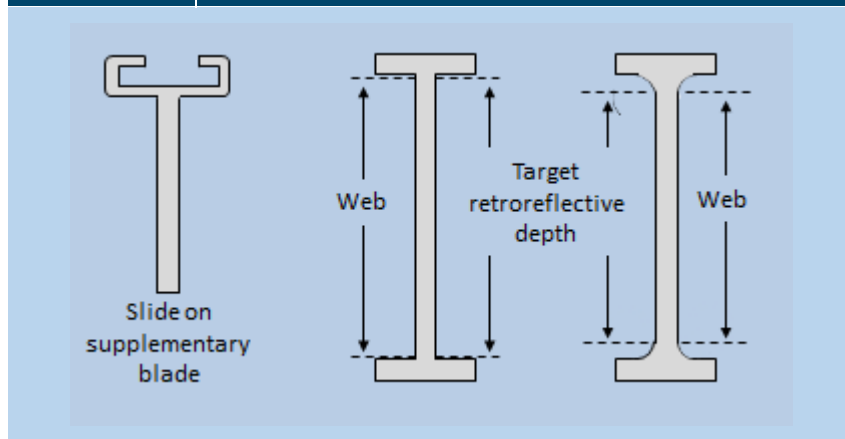

4.6.2 Brackets and fittings

Fittings shall be manufactured from durable materials i.e. stainless steel type AISI 201 or 304, cast or extruded aluminium, or steel galvanised to AS/NZS 4680 *Hot-dip galvanized (zinc) coatings on fabricated ferrous articles* after manufacture.

Fittings finished in copper, zinc or electroplated are not to be used.

There shall be a minimum of two brackets per sign (one each top and bottom). The exception to this shall be the supplementary slide on blade that is typically used for but not limited to the addition of a “No Exit” addition to the main Street Name Sign. Refer Figure 4.1. When used this supplementary blade must be specifically matched for use with the main sign and must be affixed in place using a locking screw.

4.7 Sign support systems

4.7.1 Sign supports for *Small Signs*

Sign supports shall be manufactured from one of the following materials.

- (a) **Timber posts:** Timber posts⁽³⁾ shall conform to NZS 3631 New Zealand Timber Grading Rules, No.1 framing grade, H4 treatment, dried to 20% to 24% moisture content and NZS 3640 Chemical Treatment of Round and Sawn Timber, Hazard Class H4.

The timber finish may be gauged or dressed, and shall be primed and finished with high gloss white paint above ground level.

- (b) **Steel Poles:** Steel poles⁽³⁾ shall conform to the following Standards:

AS 1163 *Cold-formed Structural steel hollow sections*

AS/NZS 1554.1 *Structural steel welding -Part 1 Welding of steel structures*

³ Refer to Clause 3.0 Definitions: Sign Support

AS/NZS 3678	<i>Structural steel – Hot-rolled plates, floor plates and slabs</i>
AS/NZS 3679.1	<i>Structural steel – Hot-rolled bars and sections</i>
AS/NZS 4680	<i>Hot-dip galvanised (zinc) coatings on fabricated ferrous articles</i>
AS/NZS 4792	<i>Hot-dip galvanised (zinc) coatings on ferrous hollow sections, applied by a continuous or a specialized process</i>

All poles shall be galvanised and or powder coated to meet the 10 year design life requirements for small signs.

(c) **Aluminium Poles:** Aluminium poles⁽³⁾ shall conform to:

AS/NZS 1866	<i>Aluminium and aluminium alloys – Extruded rod, bar, solid and hollow shapes to alloy 6261 T5 or equivalent</i>
-------------	---

All poles shall be powder coated to meet the 10 year design life requirements for small signs.

Pole caps shall be manufactured from steel, aluminium or plastic. Pole caps must be the same colour as the posts. Post caps are not required for timber posts.

4.7.2 Sign supports for *Large Signs*

Sign support systems for all signs, especially *Large Signs* (regardless of size), installed in locations over 500m above sea level and/or utilising supports greater than 2100mm apart require specific design. Refer Clause 5 Design

4.8 Foundations

Foundations shall be designed in accordance with the principles of structural statics and accepted principles of soil mechanics, taking due account of the mechanical properties of particular foundation materials.

5. DESIGN

5.1 Sign face

The sign face design, including dimensions, lettering, legends, colour and retroreflectivity, shall comply with the Traffic Control Devices Manual.

5.1.1 Retroreflective design components

The sign face design must comply with lettering formats, sizing and spacings specified by the Road Controlling Authority. The legend and background colour on signs is an important design consideration. Best practice indicates that the legend should be a colour lighter than the background (e.g. white or yellow) to ensure that the brightness of the background area does not overpower the legend, potentially making it difficult for many drivers, especially older drivers, to read.

Retroreflective signs that include a black non-retroreflective legend, such as permanent warning signs, must ensure that the legend is sufficiently bold to ensure the retroreflective area does not overpower the non-retroreflective legend. This will typically require adoption of a bolder legend as retroreflective performance increases especially when legend is lettering.

Fluorescent retroreflective sheeting is designed to provide greater colour brightness (luminance) in daylight and low light conditions such as dusk, dawn and inclement conditions. Designs must only use this where permitted or specified as a special purpose sign.

5.1.2 Protective overlay sheeting

There are two types of clear protective overlay film that can be applied over a sign face; either for protection against graffiti or the formation of dew on a sign face.

(a) Graffiti overlay

Cleaning graffiti from a sign face will frequently damage the sign face to such an extent that the sign must be replaced. A design consideration for signs to be installed in at risk locations is the use of toughened, clear sheeting designed to enable easier removal of sign face graffiti and/or the use of harsher cleaners - covered more fully in Clause 9.1.

The addition of graffiti overlay may enable a sign to be successfully cleaned several times thereby saving cost by delaying the frequency of sign replacement. This overlay may be specified or can be added based on the recommendation of the sign maintenance contractor.

(b) Dew reduction overlay

This is a highly specialised clear protective overlay film that resists the formation of dew on a sign face in cold evenings. The presence of dew can quite dramatically lessen a sign's retroreflectivity in dew affected locations; especially large guide signs. (TCD Part 1 Section 8 Retroreflectivity)

Application of this overlay reduces the formation of dew, improving sign visibility. Typically used on large overhead gantry and ground mounted guide signs the sign manufacturer must co-ordinate closely with the installation contractor to ensure extreme care when handling and installing signs with dew reduction overlay.

Dew reduction overlay cannot be cleaned and hence its use is limited to signs that are out of reach of graffiti vandalism.

5.2 Strength and rigidity

The structural design of the sign system shall comply with the criteria and procedures specified in AS/NZS 1170 and as modified below.

Wind resistance:

The design of the support system shall comply with the wind load criteria and other structural requirements in this specification

Multiple sign supports are required where the sign area or width is too large for the resistance of the environmental loads with a single support.

Multiple supports must be specified for any sign greater than 1.3m wide unless alternative calculations can establish a single post is appropriate. Where two-support mounting is required, placement of the two supports shall be equidistant from each end by one-sixth (1/6) or one-fifth (1/5) of the overall sign width in order to minimise wind deflection.

Multiple support mounting shall be restricted to the minimum number of supports required to install the sign compliant with the specification and standard.

Charts are included in Appendix B for the selection of timber, steel and aluminium supports. Provided as a guide for common sign configurations, Charts 1 to 8 are included for the selection of typical support sizes for signs with panel area less than or equal to 4.7m² (small signs) located at the roadside.

Specific design to AS/NZS 1170 is required for all signs installed at an elevation greater than 500m above sea level, in steep terrain, or signs with dimensions not covered by the charts, i.e. panel area exceeding 4.7m² (see chart notes).

The charts for the regional wind speed of 45m/s apply to Wellington and the Marlborough Sounds (Region W). The charts for a regional wind speed of 39m/s apply to all other regions (Regions A6 & A7). Wind Regions of New Zealand are identified in AS/NZS1170.2 Figure 3.1B *Wind Regions*.

The charts show typical solutions for a range of materials and cross-section shapes but are not intended to restrict the designer if other materials and cross-section shapes are available provided the design is based on AS/NZS1170 and the factors adopted in the Specification.

Table 5.1	Intended design life of sign support structures
Overhead signs, VMS signs	50 Years
Large Roadside Signs (<i>greater than 4.7m²</i>)	25 Years
Small Roadside Signs (<i>less than or equal to 4.7m²</i>)	10 Years

With the “design working life” Table 5.1 and the “importance level” Table 5.2 determined, the annual probability of exceedance of an action is obtained from AS/NZS 1170.0 Table 3.3, with the average recurrence interval used in AS/NZS 1170.2 Table 3.1 to obtain the required Regional Wind Speed (V_R) for design.

The minimum design wind pressure specified approximates the limit for truck induced wind pressures for road side sign structures adjacent to the carriageway. It also corresponds to the minimum health and safety limit in the code and thus provides a level of personal safety.

The following return periods are to be applied for wind:

Sign Type	Importance level	Average recurrence interval (years)	Probability of exceedance during the design life
Overhead signs, VMS signs	2	500	10%
Large roadside signs (panel area > 4.7m ²)	2	250	10%
Small roadside signs (panel area ≤ 4.7m ²)	1	50	18%

The wind actions shall be calculated from AS/NZS 1170.3 based on:

- Non-directional wind speed, with $M_d = 1.0$
- Minimum terrain category 2 (for Overhead and VMS Signs)
- Effects of shielding ignored, with $M_s = 1.0$
- Minimum site wind pressure of 800 Pa
- Design wind speed ≥ 30 m/s

5.3 Load factors and stress reduction factors

Sign Panel to Sign Support Connections

Sign panel to sign support connections shall be designed for a force that is at least equivalent to 1.25 times the force used for the design of the sign support.

In extreme events it is desirable to have a controlled failure mechanism. For example, sign supports should fail in flexure before the sign panel to sign support connection fails, or the foundation fails. To ensure this type of failure mechanism, load factors and strength reduction factors have been specified for the design of the connections to the sign panel and for the design of the sign support foundations.

5.4 Serviceability limits

For the design of the sign supports for signs with an area less than 4.7m^2 , the serviceability limit state deflection should not exceed $h/20$ calculated at the top of the sign (ignoring foundation rotation), where h is defined as the free cantilever length. Deflections of large sign supports shall be subject to specific design. Parking and median mounted signs with a high probability of impact may be designed with a lower rigidity requirement than that specified above.

Deflection of sign panels relative to their supports shall be limited to a maximum temporary deflection of $L/40$ of the appropriate span when subjected to the serviceability design wind pressure, where L is defined as the span between supports, or between the support and the panel edge. The relative deflection of adjacent sign panels, in multi-panel signs, shall not exceed 1.0 mm when subjected to the serviceability design wind pressure.

5.5 Foundation design

The foundations shall be designed in accordance with the accepted principles of soil mechanics, taking into account the soil properties of the foundation material and due account of the water table and sloping ground.

- (a) For small roadside signs with an area less than 4.7m^2 a soil strength reduction factor of not more than 0.6 shall be adopted.
- (b) For large signs with an area greater than 4.7m^2 and signs over a carriageway a lower soil strength reduction factor of between 0.45 and 0.6 may be appropriate depending on the level of site investigation and construction control (refer to NZBC – B1/VM4, 2000).
- (c) Where not specifically designed, the minimum sign support planting depth shall be one fifth of the mounting height, but not less than 1 metre depth.

The contractor installing the sign is responsible for ensuring that the sign support foundation design is according to an acceptable method for the design of foundations for sign supports embedded in the ground, or in bored concrete foundations. This specification recognises the Broms method (as presented by H. Poulos and E. Davis, 1980) but Transport Agency accepted alternatives may be adopted and listed in Appendix F.

Tables 1 to 8 are included in Appendix C for the selection of appropriate embedment depths for cast in-situ concrete cylindrical foundations in a range of soils based on the Broms method.

Table 8 is included for the selection of shallow pad foundations in areas where underground services are an issue. The tables are based on a soil strength reduction factor of 0.6.

Specific foundation design is required for foundations in soils outside the indicative parameters given in the tables and for large signs with a panel area greater than 4.7m^2 or all signs over a carriageway.

Foundations and in ground elements of breakaway sign supports shall not protrude more than 100mm above finished ground level. Foundations should generally be constructed flush with or below the ground profile. The bottom flange of the in-ground element of a breakaway sign support shall not exceed 100mm above the ground profile over a 1.5m length. See Figure 5.1.

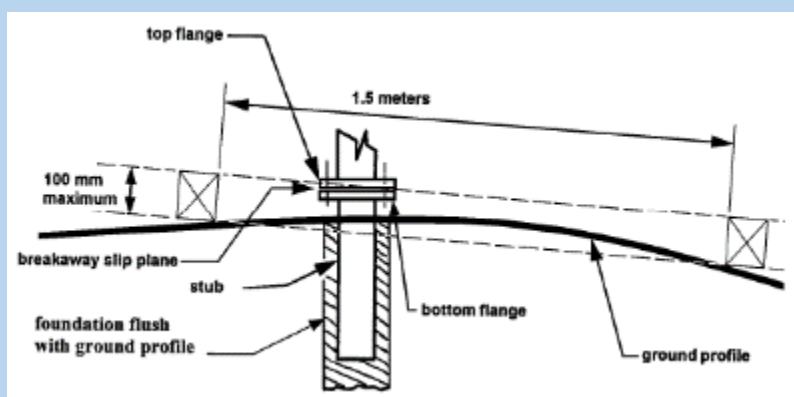
Figure 5.1 Breakaway Support Maximum Stub Height

5.6 Resistance to twisting

The sign foundation, construction, clamping arrangements and installation of signs to single sign supports shall not allow twisting about any axis of rotation greater than 5° residual rotation of the sign by reason of permanent set or slippage.

Twist test method: When testing the twist performance of a sign, the sign panel shall be attached to a sign support in the same manner as that used in service.

For signs supported on a single axis or at one end, the sign support shall be supported horizontally and must be free to deflect under test load.

A test load of 625N shall be applied at a rate of between 6N/s and 8N/s at the extremity of the sign so as to provide maximum torque about any axis of rotation. The sign shall be loaded with the test load at its extremity for a period of 5 minutes. The rotation of the sign shall be measured whilst under the load and 5 minutes and 10 minutes after removal of the load.

5.7 Sign support design

The following detail refers to sign supports required for Guide, Motorist Service, Tourist and Road Safety Campaign Signs.

The hardware and corresponding safety treatment of sign supports varies with the sign category which is divided into three main categories:

- Sign support systems for overhead signs,
- Sign supports for small roadside signs.
- Sign supports for large roadside signs.
- The intended design life for sign support systems and methods is specified in Table 5.1

In place of designing a specific sign support system, where practicable, appropriate and accepted, overhead signs shall be designed to be installed on nearby overpasses or other existing structures. Prior to the adoption of an existing structure the installation contractor must establish that the structure and attachment systems can withstand the added weight and wind loading that may become evident.

Signs shall not be partially or wholly installed on utility supports i.e. power poles etc

Overhead Signs:

Overhead signs support systems, including cantilevered structures, frequently require significant support systems where the ground connection cannot be made breakaway. All overhead sign supports located within the roadside shall be specifically designed to AS/NZS 1170 and be shielded behind a compliant safety barrier system.

Small traffic signs:

Defined as those signs having a sign panel area less than or equal to 4.7m² installed in locations less than 500m above sea level and/or supported on sign supports less than 2100mm apart. All signs installed in excess of 500m above sea level and/or on supports more than 2100mm apart require specific design and testing to AS/NZS 1170.2 and AS/NZS 3485.2. Each support shall have a mass less than 25kg/m².

- (a) Single Sign Support Installation: Subject to the requirements of Clause 6.5.1 Sign stiffening and Appendix B (Sign support selection Charts for Small Signs), generally signs under 1.3m wide shall be installed on a single breakaway support. Refer to Sign Support Selection Chart Clause 8.4 for details of sign mounting height, compliant Breakaway Supports and foundation details.
- (b) Multi Sign Support Installation: Subject to the requirements of 6.5.1 Sign stiffening and Appendix B (Sign support selection Charts for Small Signs), signs over 1.3m wide and with a sign panel area less than or equal to 4.7m² shall be installed on a two breakaway supports spaced no further than 2.1m apart. Refer to Sign Support Selection Chart (Clause 7.5) for details of sign mounting height, compliant Breakaway Supports and foundation details.

Large Traffic Signs

Defined as those signs supported on two or more supports that:

- (a) Have a sign panel area exceeding 4.7m² and/or
- (b) All signs installed 500m above sea level and/or
- (c) All signs installed on supports greater than 2.1m apart.

Specific Design is required for breakaway supports refer to Clause 7.6 Schedule B

5.8 Impact performance for sign supports

The sign installation contractor must be aware of where signs may be installed relative to the sign supports resistance to impact.

Support systems for signs installed in the roadside shall be designed, manufactured, installed, and maintained to comply with AS/NZS 3845 Part 2.

Sign support systems that do not comply with AS/NZS 3845 Part 2 may not be installed in the roadside unless shielded by:

- (a) A road safety barrier system compliant with NZTA M23 Specification for Road Safety Hardware Systems. In all cases, sign supports shall be located clear of the space required for the dynamic deflection and the proper performance of the barrier; or

- (b) A fixed impact attenuator, designed to resist both end-on and side impact by vehicles, compliant with NZTA M23 Specification for Road Safety Hardware Systems.

The road controlling authority may decide that in specific situations such as in urban and other low speed areas the risk of injury to pedestrians and cyclists from breakaway type sign supports exceeds that of the vehicle occupants, in the event of a crash, and so specify that conformance to this section does not apply. Examples of sites where breakaway supports may be imprudent are adjacent to bus shelters or in areas of pedestrian concentrations.

The concept of 'frangible supports' remains relevant to the requirements and is clearly defined; however it forms only one of the criteria that are evaluated. Other factors that must be considered are the forces that are imparted to the vehicle as the support yields or breaks away and the trajectory of the sign if it breaks away from the foundation.

6. MANUFACTURING

In order to ensure that the finished sign meets all required design standards the manufacturing process must not be amended without approval.

6.1 Sign face

All sizing, lettering, legends and colours shall comply with Traffic Control Devices Manual

All legends, symbols and borders must be applied using a retroreflective colour process system compliant with NZTA M25 with either *Interim Approval* or *Approved Material* status.

The application of any sign colour by the sign manufacturer must be according to the sheeting manufacturer's requirements using match component materials and systems to ensure that sign warranties will be recognised. The application of colour may be applied either before or after application of the sheeting to the flat base panels.

Application of colour may be achieved by:

- (a) A silk screening process applying either transparent or opaque inks
- (b) The application of a transparent coloured film
- (c) By using a digital printing system that applies either transparent or opaque inks. In this system the printed image may or may not be required to have a clear overlay film applied. It is important to ensure that the finished sign face does comply with the sheeting manufacturer's recommended process that has been tested for Transport Agency's compliance and approval.

To ensure complete compatibility and durability between materials, all process inks, clear coats, colour films and digital print systems must be supplied or recommended by and applied according to the sheeting manufacturer's specifications.

As an alternative process, legends, symbols and borders may be fabricated by an overlay process. Where reflective or non-reflective materials are used in this overlay process, those materials used must be consistent with the intended life of the sign as contained in the Specification.

6.2 Retroreflectivity

Preparation of the sign substrate and application of retroreflective sheeting must be in accordance with the sheeting manufacturer's/suppliers warranty conditions.

Retroreflective sheeting shall be applied to properly prepared blanks by the squeeze roll applicator process. Edges shall be trimmed from the face side and cut cleanly and level to the sign panel without overhang.

Retroreflective sheeting shall cover the sign panel in one piece. In instances where this is not possible, joints must be completed according to the retroreflective sheeting manufacturer's specifications.

Sign manufacture must specify the use of one of the five retroreflective sheeting Classes listed in NZTA M25 and noted in Table 6.1. This sheeting must have *Interim Approval* or *Approved Material* status confirmed in the New Zealand Gazette as specified in NZTA M25.

TABLE 6.1: AS/NZS 1906.1 Retroreflective Classes		
Current Class	Generic Name	Previous 2007 Class
Class 100	Engineer grade – <i>glass bead or prismatic</i>	Class 2*
Class 300	High intensity – <i>Glass Bead</i>	Class 1
Class 400	High intensity – <i>Prismatic</i>	Previously included as Class 1
Class 900	Standard wide observation angle – <i>Prismatic</i>	Class 1W Replaced using higher R_A values
Class 1100	Optimum wide observation angle – <i>Prismatic</i>	New Class
*Class 2A specified in 2007 has been discontinued in 2017		

The sign manufacturer must ensure that each retroreflective sheeting colour used in the manufacture of a large sign requiring a number of separate panels comes from the same roll or same batch of sheeting or as a minimum that the colour on separate panels is colour matched to avoid possible batch differences degrading the signs overall finish.

The sign manufacturer's identification sticker plus appropriate engraving, etching or similar (Clause 4.1) must be added onto the back of the sign and must include the date or such code that indicates the date from which the signs warranted life, and *intended life* will commence.

6.3 Retroreflective compatibility

In order to ensure a balanced performance across a multi coloured retroreflective sign to be viewed in daylight and at night, the manufacturer must ensure that all colours are from the same sheeting class to ensure that no single colour overpowers the sign (contrast ratio).

Sign colour typically identifies a specific sign message or legality. Manufacturing must therefore ensure that the colour and design as specified complies with the TCD Manual Part 1 Section 8 reproduced here as Table 6.2 to detail current colour usage. Any variation from this must be approved by the Transport Agency.

If the Road Controlling Authority (RCA) or client's specifications vary from conformance as stated the sign manufacturer must seek design confirmation prior to commencing manufacture.

The sign manufacturer should question specifications prior to commencement when:

- (a) a sign background is to be a colour lighter than the legend
- (b) specified black legend seems inconsistent for use with the specified retroreflective sheeting Class
- (c) use of a fluorescent colour is questionable
- (d) non-retroreflective legend or background for permanent signs has not specified a minimum durability of at least 10 years

TABLE 6.2:	
Colour	Typical use (<i>any usage outside this must be approved</i>)
White	<ul style="list-style-type: none"> • Sign legends • Some regulatory signs have white as the base colour.
Yellow	<ul style="list-style-type: none"> • Background colour permanent warning signs • Legend on blue background toll road guide signs
Red	<ul style="list-style-type: none"> • Background for regulatory signs • Some specifically approved safety signs • Legend for some regulatory signs
NZ Green	<ul style="list-style-type: none"> • Background for road controlling authority street name signs
Dark Green	<ul style="list-style-type: none"> • Background for state highway, motorway and expressway guide signs
Blue	<ul style="list-style-type: none"> • Background for road controlling authority street name signs. • Background for district highways guide signs. • Background for some regulatory signs.
Brown	<ul style="list-style-type: none"> • Background colour for tourist guide signs
Orange	<ul style="list-style-type: none"> • Background colour for temporary work zone signs
Fluro Yellow	<ul style="list-style-type: none"> • Background colour for special permanent warning signs in disadvantaged locations
Fluro Yellow Green	<ul style="list-style-type: none"> • Background colour for vulnerable road user warning signs • Edging addition for some special regulatory signs
Fluro Orange	<ul style="list-style-type: none"> • Background colour for temporary work zone signs

While the application of graffiti overlay protective film is relatively straight forward, signs that have dew resistant protective overlay applied must be handled strictly according to the suppliers specifications both in manufacture and any handling post manufacture. The sign manufacturer must ensure that the installation contractor is aware of these handling requirements and the need to wash the sign face after installation with clean water.

6.4 Sign blanks

Sign blanks shall be formed using compliant material.

Unless otherwise specified on the drawings tolerances on sign blank dimensions shall be as follows:

- (a) The overall dimensions of the sign blank may be adjusted by a maximum of $\pm 5.0\%$ of the original designed dimension in order to allow efficient use of raw materials. This adjustment may not be applied to symbols, lettering or any other elements of the sign face.
- (b) Hole size tolerance shall be $-0/+1$ mm.
The holes centre dimension (geometric position):
 - Mating hole centres, tolerance ± 1 mm.
 - Non-mating hole centres, tolerance ± 3 mm.
- (c) Maximum allowable warp, twist or departure from flatness, except for any departures prescribed by the drawing to increase stiffness shall be 3mm/metre.
- (d) Blank squareness of a single panel sign shall have no corner of the panel shall be more than 2mm from its theoretical position relative to other corners.

In the case of multi-panel signs, adjacent panels shall be rectangular and fit together so that any gap between panels is not less than 1.0mm and not more than 1.5mm wide along the edge of the join.

All signs must have radius corners finished in accordance with sign layouts.

- (e) All edges shall be smooth and true.

Sign plates and extrusions, including cutting, rounding of corners, and punching of holes shall be completed prior to degreasing, etching and the application of the retroreflective sheeting or painting.

6.4.1 Sign blank jointing

Sign blanks shall be constructed such that the number of sheets be kept to a minimum and the separate sheets be rectangular and approximately the same size and shape.

Horizontal panel joints shall not occur through any internal border, or through any word or numeral legend or character height 100mm or less other than the descenders of any lower case legend.

For horizontal joints a length of channel stiffening terminating 20 ± 5 mm short of the edge of the sign may be considered as part of the horizontal bracing when used to cover the joint.

Vertical joints shall be located so as not to have any legend directly over the joint.

Where there are two or more parallel joints in a blank, the centre panel or panels so formed shall not be narrower than the outside panels.

The backing plate for vertical joints shall be a cover strip of the same material as the sign substrate, 60 ± 5 mm wide, terminating 10 ± 5 mm short of the edge of the sign and discontinued at each horizontal stiffening section or cover strip with a gap not exceeding 5mm. A cover strip over a vertical panel joint may be omitted if the calculated length of the cover strip would be less than 100mm.

All cover strips shall be coloured on both sides with the same colour as the back of the sign. (Refer Section 6.6 (c)).

6.4.2 Aluminium sign substrate

Aluminium substrate sign backing plates shall be attached to each blank panel, by a single row of rivets evenly spaced across the sign at a spacing not exceeding 200mm with an edge distance not exceeding 30mm from the end of the cover strip. A Transport Agency accepted fixing system of equivalent strength and durability may be used. (Refer Appendix F).

6.4.3 Alternative sign substrates

Prior to the introduction of any alternative sign substrate to be used as part of a *Matched Component Sign System* it must comply with the requirements specified in Appendix E

6.5 Sign stiffening

6.5.1 Stiffening of aluminium substrates

Aluminium sign blanks shall be stiffened using an NZTA accepted stiffening system (refer Appendix F).

Attachment of channel extrusions to aluminium blanks must be:

- (a) By means of 3mm carbon steel and mechanically zinc plated blind rivets fixed through the sign face prior to the application of the retroreflective sheeting. Where rivet heads are exposed, the rivet heads shall be coloured to match the sign background. The maximum distance between adjacent rivets shall be not more than 200mm with rivets spaced equally across the sign face except that at each end of the channel, 2 rivets shall be spaced within 30mm of each other. Alternatively, fixing systems of equivalent strength and durability may be used if accepted by the Transport Agency (Appendix F).
- (b) Where a sign is required to be finished with unexposed rivet heads, they shall be fitted flush with the surface of the sign blank. Channel extrusions must be attached prior to the application of retroreflective sheeting, using either 3mm carbon steel and mechanically zinc plated blind rivets or counter sunk blind rivets of equivalent strength and durability. Alternative, fixing systems of equivalent strength and durability may be used only after acceptance by the Transport Agency (Appendix F).
- (c) Channel extrusions on signs under 6100mm in width must be continuous across the sign blank without breaks or joints, with extrusions terminating not more than 50mm from the edge of the sign. Channel extrusions on signs over 6100mm in width shall be joined using an approved channel coupling as per the manufacturer's specification.
- (d) Stiffening is to terminate no less than 50mm from each edge of the sign panel with rivets being spaced no more than 200mm equally across the sign face. In addition, 2 rivets within 30mm of each other are required at channel ends.
- (e) Channel spacing in conjunction with post centres shall be calculated in accordance with manufacturer's published charts and shall conform to deflection requirements of the specification. Channel manufacturers shall make available engineering calculations and channel/post spacing charts with calculations conforming to NZS 4203.
- (f) Stiffening of non-directional Permanent Warning and Regulatory Signage shall consist of no less than 2 channel extrusions fixed horizontally across the back of the sign, as per the channel manufacturer's recommendations. (Refer Appendix A)

6.5.2 Alternative sign substrate stiffening and fixing components

Prior to the introduction of any alternative sign stiffening and fixing componentry to be used as part of a *Matched Component Sign System* such items must comply with the requirements specified in Appendix E

6.6 Preparation and painting

Paint or alternative powder coating used for the backs of traffic signs shall be of proven quality consistent with the intended life of the sign.

- (a) Aluminium sign blanks shall be prepared for painting in accordance with the paint supplier's specifications. Sign blanks shall be degreased and oil free, etched with self-etching primer or phosphating process.
- (b) All sign blanks for reflectorised signs shall be prepared in accordance with the retroreflective sheeting manufacturer's specifications.
- (c) Unless otherwise specified, all panel backs shall be coloured 'Aircraft Grey' No 693 of the British Standard BS 381C (Pantone Colour System PMS 431). The finish must be either semi-gloss or matt to reduce the potential for specular glare. For further detail refer to TCD Manual Part 1 Section 5 Clause 5.1.2.

7. SIGN INSTALLATION

Visibility of a sign is affected by a number of factors including the sign position and orientation on site, road/site geometry, vehicle headlamps, the driver, and the sign face size, colour, brightness and contrast. The Specification assesses only two attributes of sign materials – luminance and contrast. It is assumed that the sign is correctly designed and installed so that other factors important in making the sign visible, such as the class of retroreflective material and the location of the sign on site, have already been correctly accounted for.

7.1 Packing handling and transportation

All signs shall be packed and handled in accordance with the retroreflective sheeting manufacturer’s recommendations and in all cases signs shall arrive at their destination in new condition.

At all stages prior to installation, signs shall be stored on edge and handled in a careful manner to avoid damage, and the recommendation of the sheeting manufacturer shall be followed at all times.

At no time during storage at the manufacturing plant, during delivery, or at a construction site shall packs of signs be allowed to become wet. To avoid damage resulting from moisture, signs should not be stored in any type of packaging materials.

Care must be taken when transporting signs that their position does not risk damage from falling objects. In many instances, especially with large sign panels it is best to transport them on edge, secure with padding and separate panels with a divider timber.

On completion of sign installation the *Sign Installer Confirmation of Compliance sticker* or label plate that confirms compliance for the “*Sign Installation*” must be affixed to the back of the sign. (Refer Clause 4.2)

7.2 Principle of retroreflectivity

The contractor should be aware that a retroreflective sign, incorrectly installed, directly in front of a vehicle’s line of approach may result in the headlights *mirror-reflecting* as in Figure 7.1(b) from the signs shiny surface, thereby increasing sign glare and dazzle detrimentally affecting the driver’s ability to see a signs true retroreflective performance as shown in Figure 7.1(a).

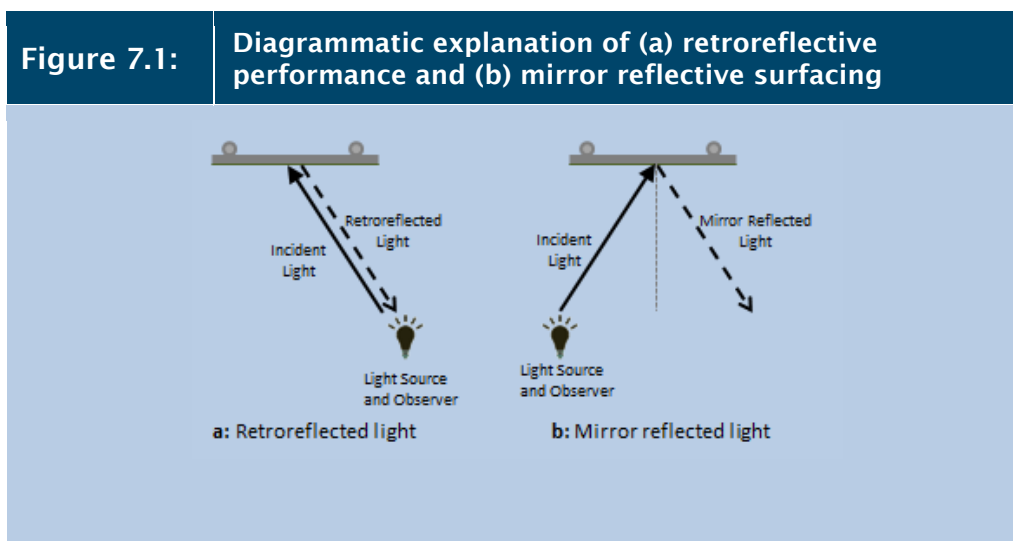

7.3 Positioning

The Installation Contractor must be aware of all the peculiarities of the site.

Careful siting may reduce environmental soiling of a sign and consequent increase in maintenance/cleaning costs. Full advantage of the height range allowable in the Traffic Control Devices Manual should be taken to keep signs above traffic spray.

Signs must be orientated away from a vehicles line of approach as outlined herein and the *Austrroads Design Guides* shall be used, with due regard to visibility, safety and maintenance peculiarities of the site.

Whilst the general siting of the sign should be stipulated by the specifier, the installation contractor should ensure that adequate sight distance is provided to the sign. Sight distance is related to the posted speed for the road. This clear distance can be affected by the road geometry (horizontal and vertical alignment), terrain (particularly on the inside of horizontal curves) and roadside objects (such as trees and other signs and road side furniture).

Roadside features (such as embankments and vegetation) that prevent adequate sight distance being achieved should be removed or modified to ensure sufficient visibility. Alternatively the installation contractor should consider a revised sign location, with local road controlling authority if this is required.

It is important that roadsides are maintained to ensure that sight distance requirements are sustained, for example by regularly pruning trees and cutting grass.

The contractor must be familiar with the two critical angles referred to by specifiers when referring to retroreflective sheeting performance. These two angles are:

- (a) Entrance Angle: The angle formed between a line taken from the headlights to the perpendicular of the sign face. (Figure 7.2a) Vehicle 2 is said to have a greater entrance angle than Vehicle 1.

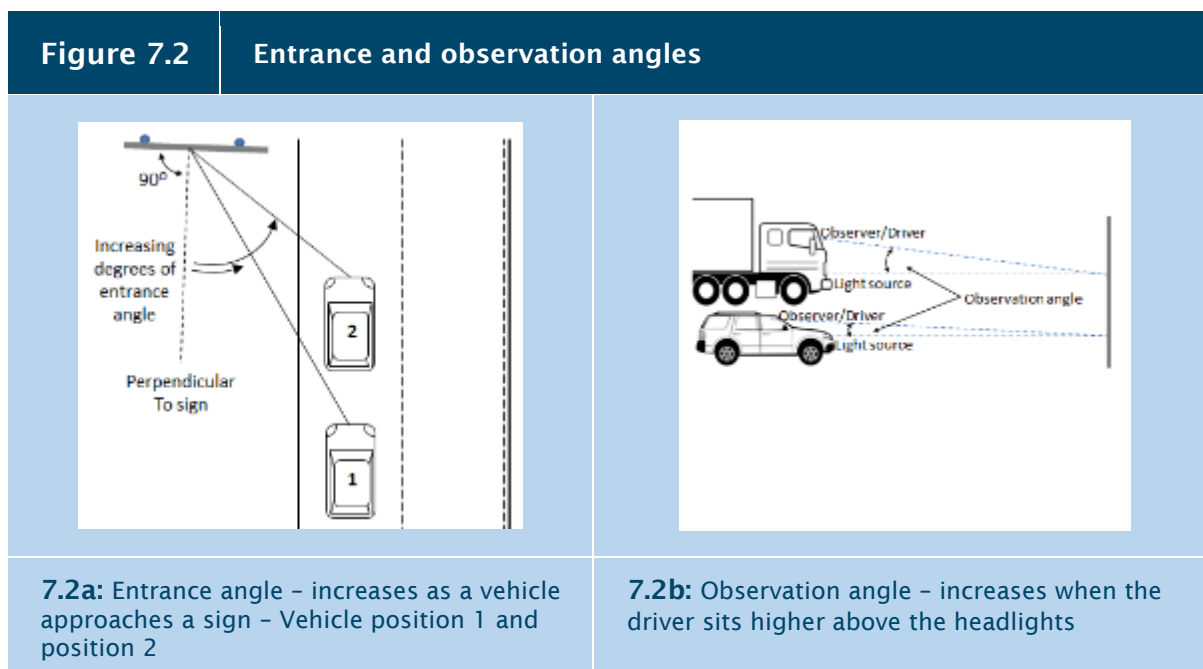

- (b) Observation Angle: The angle formed between the line drawn from the headlights to the sign and the line drawn from the driver's eye position to the sign. (Figure 7.2b) The truck creates a greater observation angle than the family vehicle.

7.4 Orientation

The orientation of a traffic sign to oncoming traffic is extremely important. Commercial non-retroreflective signs typically face the driver's line of approach but when using retroreflective sheeting the traffic sign should be facing five degrees away from the driver's line of approach. This is to reduce possible and undesirable mirror reflection from a shiny sign surface that can dazzle the approaching driver and /or make a sign difficult to read.

The orientation of a traffic sign must also be appropriate for the traffic environment. A traffic sign placed at a certain angle, where it can be seen by a driver, must not mislead or distract other drivers for whom it is not intended. For example, a traffic sign located adjacent to a slip lane might be seen by drivers travelling parallel on the main road. Further specific information on sign sheeting and retroreflection is included in Section 8 of the TCD Manual.

Figure 7.3: Sign angled 5° away from the vehicles line of approach reflects specular light away from the road.

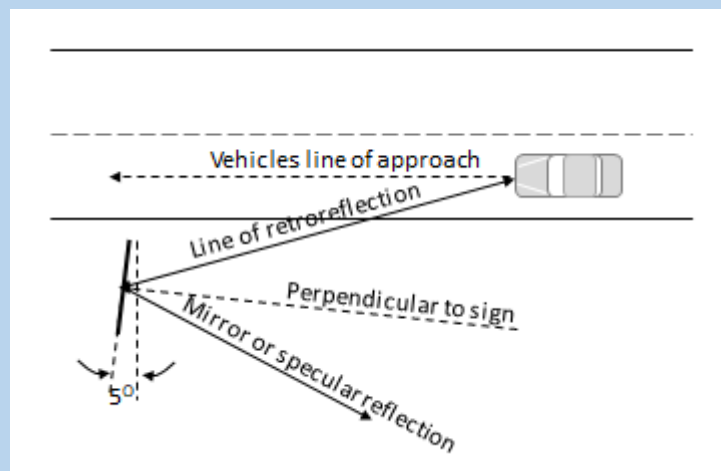

Sign specifiers and installers must take care to ensure that traffic signs, especially large ground mounted guide signs, are installed at the correct orientation or angle relative to a vehicle's line of approach.

These signs located to the left or right side of the road must be set at approximately five degrees (5°) away from a vehicle's line of approach. This then directs any specular or mirror reflection, from the shiny surface of the sign, away from the road leaving only the specified retroreflection returning to the driver. (Figure 7.3)

Do NOT angle signs towards the road (Figure 7.4) The addition of specular/mirror reflected light to retroreflected light risks the sign being too bright, potentially dazzling the approaching driver.

Standard size Regulatory and Permanent warning signs should equally be set at 5° away from a vehicles line of approach unless a two sided sign is to be seen from both approach directions in which case the sign must be set at 90°.

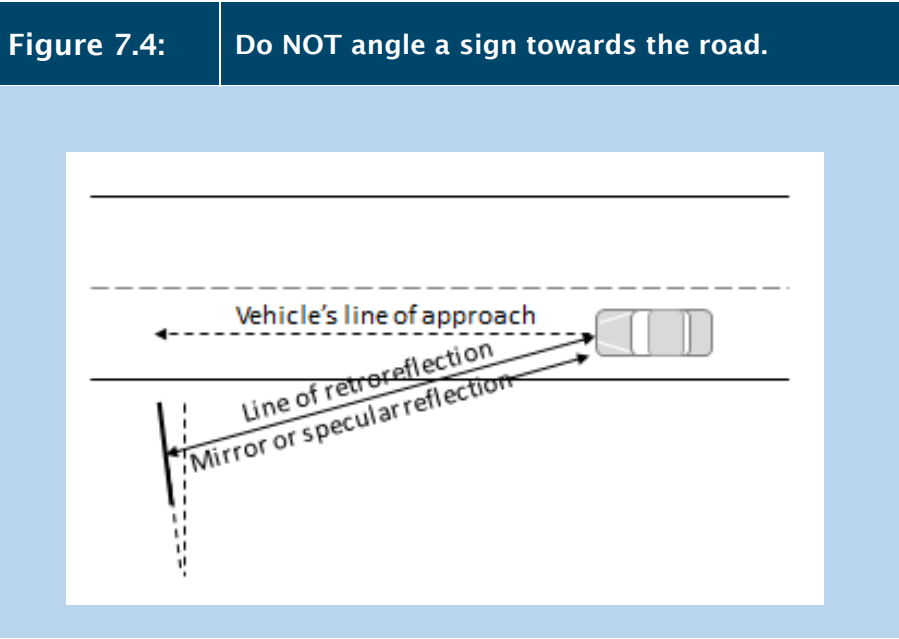

Care must also be taken when installing large Chevron Boards and Permanent Warning signs. Large Chevron Boards are typically positioned directly in front of the lane of the approaching vehicle. Angled at 90° to the oncoming traffic risks specular reflected light creating a blinding dazzling effect for the approaching driver. (Figure 7.5)

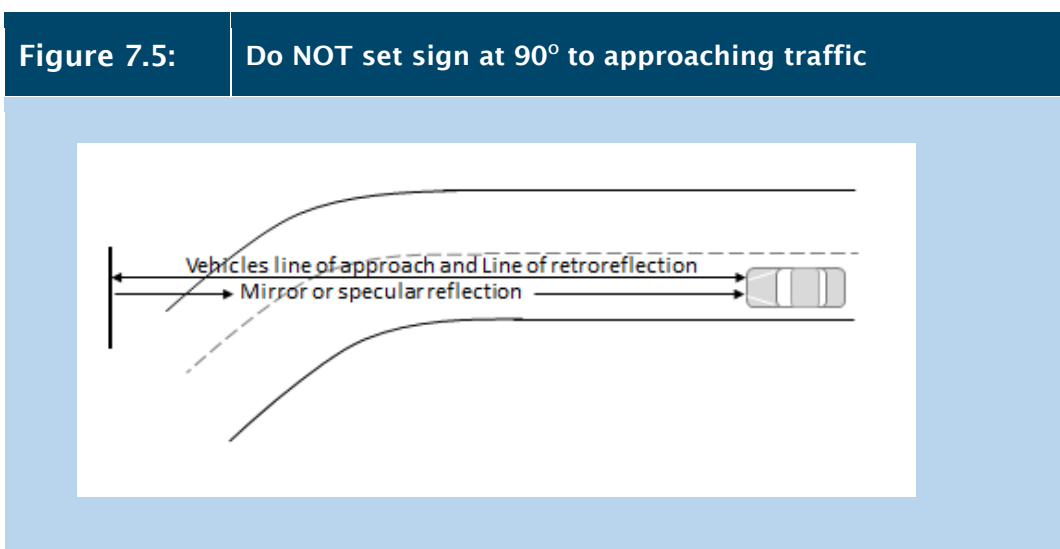

The chevron board must be angled at no less than 5° in order to direct any specular/mirror reflected light away from the road. (Figure 7.6)

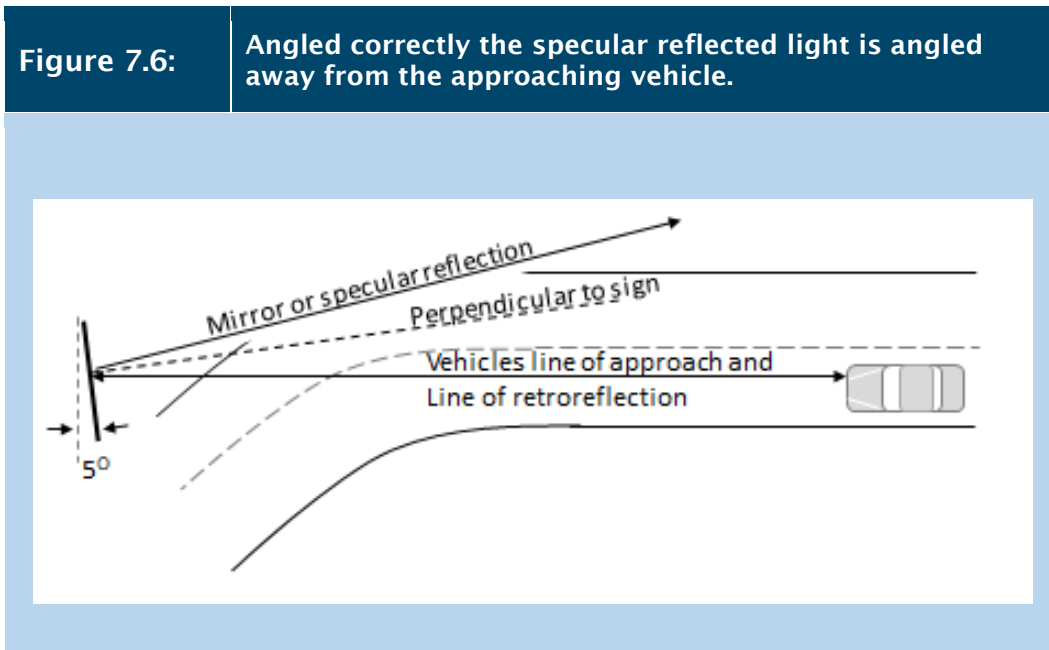

Overhead gantry guide signs may generally be installed at 90° to the approaching traffic since any specular light is reflected well over the approaching vehicle. (Figure 7.7)

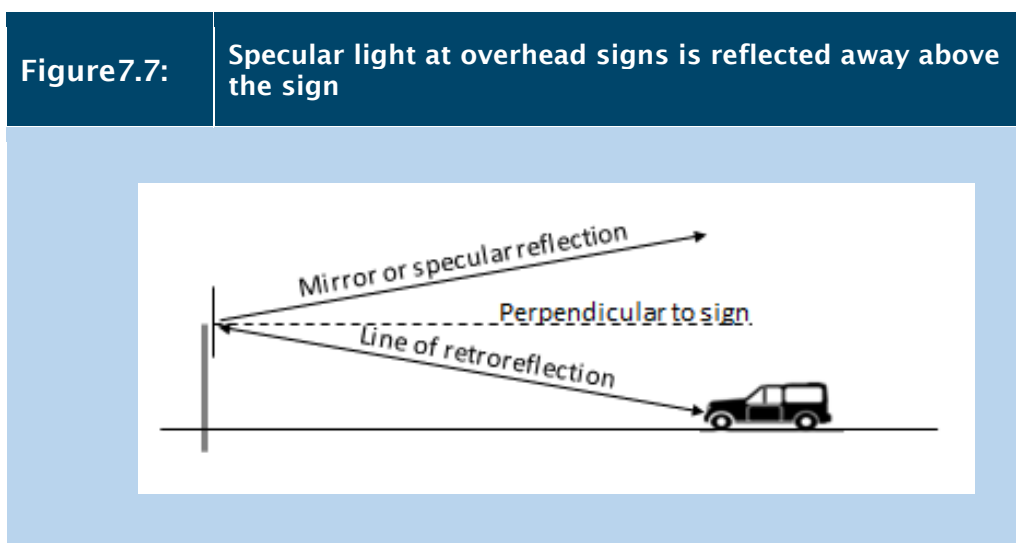

However where the road gradient approaching the sign is at a higher point on the road, such as for a vehicle approaching over a vertical curve equalising vehicle and sign height risking specular glare, it may be wise to angle this gantry at 95° to the line of approach.

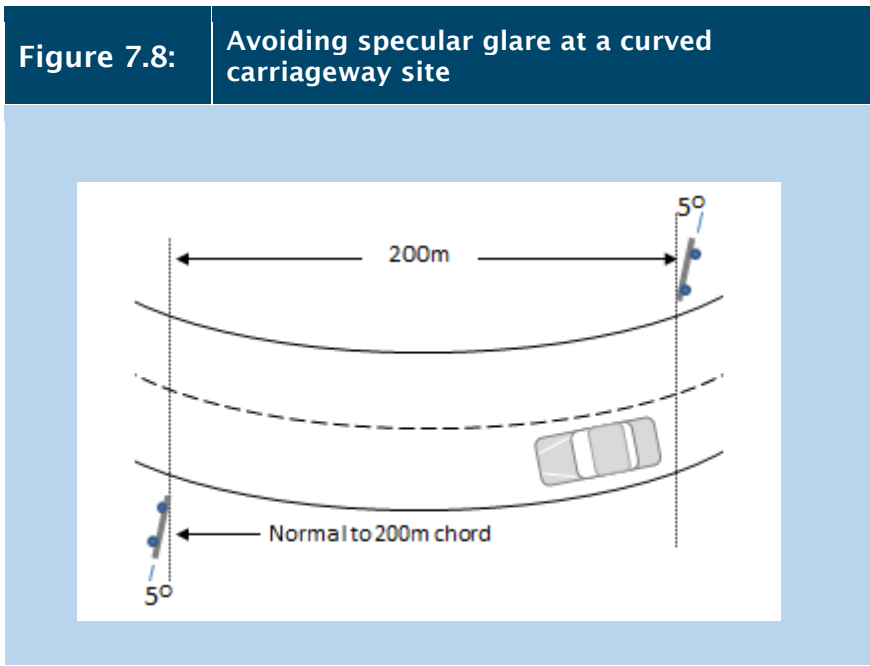

A traffic sign at a curved situation must be positioned and angled as shown in Figure 7.8 This will lessen any effects of specular glare that could eventuate from either direction.

TIP: Checking sign orientation in the field

A method that can be used to check a sign is orientated correctly is to place a builder's square on the face of the sign. If the square is pointing to the approaching vehicle then the angle is incorrect.

The installation contractor should also be aware of any objects that may obscure part or all the sign at some point of the approach. Good practice includes a drive by the site before installation if there is any uncertainty regarding tree overhang or other signs.

It is good practice for the contractor to drive by after sign installation as a final check that the installation is to specification and that spelling is correct.

7.5 Sign support selection

Table 7.1:		Sign support selection criteria				
Sign type	Minimum Mounting heights ⁽¹⁾	No. of sign supports	Compliant sign supports	Support selection	Foundation design	
<ul style="list-style-type: none"> Regulatory Permanent Warning 	Rural 1.5m Urban 2.0m Over footpath 2.5m	1	Refer 7.6 Schedule A	Appendix B	Appendix C	
SMALL SIGNS: less than 1.3m wide						
<ul style="list-style-type: none"> Guide Motorist Service Tourist Road safety Campaign 	Rural 1.5m Urban 2.0m Over footpath 2.5m (exception is low mounted Traffic Island IDS signs)	1	Refer 7.6 Schedule A	Appendix B	Appendix C	
SMALL SIGNS: max 4.7m² & sign supports less than 2.1m apart Installed max 500m above sea level						
<ul style="list-style-type: none"> Guide Motorist Service Tourist Road safety Campaign 	Rural/Urban 2.1m Over footpath 2.5m (exception is low mounted Traffic Island IDS signs)	2	Refer 7.6 Schedule A or Schedule B	Appendix B	Appendix C	
LARGE SIGNS: over 4.7m² &/or sign supports greater than 2.1m apart &/or all signs installed over 500m above sea level						
<ul style="list-style-type: none"> Guide Motorist Service Tourist Road safety Campaign 	Rural/Urban 2.1m Over footpath 2.5m	2 or more	Refer 7.6 Schedule B	Schedule B approved products or part of specific design to AS/NZS 1170	Foundations require specific design	
⁽¹⁾ Mounting height is measured from underside of sign to surface of adjacent road, trafficable shoulder or top of kerb.						

7.6 Sign supports and impact requirements

Schedule A

Signs that are constructed within the limitations of this section are deemed to comply with the specification for Small Traffic Signs by using the following sign supports:

- (a) Timber posts ⁽⁴⁾ (Radiata Pine No: 1 framing, H4 treatment) not exceeding size 100mm x 100mm direct embedment without further treatment.
- (b) Steel poles⁽⁴⁾⁽⁵⁾, CHS (circular hollow section) not exceeding 76mm outer diameter and wall thickness not exceeding 3.2mm, Grade 350, or RHS (rectangular hollow section) 75mm x 50mm outer dimension with a wall thickness not exceeding 3.0 mm, Grade 350.
- (c) Aluminium poles ⁽⁴⁾ manufactured in grade 6261-T5 or equivalent (255MPa yield strength) not exceeding a 114mm outer diameter with a minimum wall thickness of 4.7mm (trough) and 5.5mm (crest).
- (d) Sign supports listed as a MASH tested and approved breakaway system under the FHWA Roadway Departure Sign Supports listing. (Refer to AS/NZS 3845 Part 2, FHWA Web Page and or Appendix F).

Schedule B

Signs that are constructed within the limitations of this section are deemed to comply with the specification for Small and Large Traffic Signs and shall be achieved by:

- (a) Specific design to NZS1170 and NZTA acceptance (Refer Appendix F) or
- (b) Utilising breakaway supports that conform to AASHTO 2001 “Standard Specifications for Structural Supports for Highway Signs, Luminaires and Traffic Signals” and have been crash tested and accepted in accordance with the requirements of MASH (Refer to AS/NZS 3845 Part 2 and FHWA Web Page)

The following limitations shall apply:-

- (i) The sign support manufacturer shall provide a sign support selection formula based on Structural Performance, Breakaway Dynamic Performance, Wind Loading design and Design Life.
- (ii) An approved hinge device shall be fitted immediately below the sign panel. No supplementary signs shall be attached below the hinges if such placement is likely to interfere with the breakaway action of the sign support or if the supplemental sign is likely to penetrate the windshield of an impacting vehicle.
- (iii) Each sign support shall have a mass no greater than 65kg/m. The total mass below the hinge but above the shear plane of the breakaway base device shall not exceed 270kg.

⁴ The embedment type for timber posts and the maximum size specified for steel and aluminium poles is based on published FHWA test data.

⁵ This section relates to the maximum wall thickness/tensile strength that is deemed to comply with Impact Requirements. In order to provide the end user with a sign support that meets these requirements and is readily available, Sign Support Selection Charts are provided in Appendix B for steel CHS poles 60 and 76mm outer diameter, wall thickness 2mm, Grade 350. Suppliers of poles outside these properties shall provide separate pole Selection Charts.

- (iv) The minimum mounting height to the underside of the sign shall be 2.1 m. (Note: Although the TCD Manual allows a minimum mounting height that in some circumstances is less than 2.1 m, such signs do not qualify as “deemed to comply” with the requirements of the Specification).
- (v) Breakaway base devices must not be located more than 100mm above the average ground level within 1.5m of the sign post. Refer Figure 5.1.
- (vi) Multi (Omni)-Directional breakaway devices should be used where impact from any direction is possible. Inclined Slip Base Breakaway devices shall not be used.
- (vii) Sign Stiffener spacing shall be calculated in accordance with the sign stiffener manufacturers’ recommendations relating to post centres and overhang to comply with deflection requirements of the Specification.

7.7 Foundations

Sign supports shall be carefully located to ensure that the breakaway devices perform properly as designed to minimise the seriousness of impacts by errant vehicles e.g. sign supports should not be placed in drainage ditches where erosion and freezing might affect proper operation of the breakaway mechanism.

Supports placed on roadside slopes shall not allow impacting vehicles to snag on either the foundation or any substantial remains of the support. Surrounding terrain shall be graded to permit vehicles to pass over any non-breakaway portion of the installation that remains in the ground or rigidly attached to the foundation.

Figure 5.1 illustrates the method used to measure the required 100mm maximum stub height.

Breakaway support mechanisms are designed to function properly when loaded primarily in shear. Mechanisms are designed to be impacted at bumper height, typically 500mm above the ground. If impacted at a significantly higher point, the bending moment in the breakaway base may be sufficient to bind the mechanism resulting in non-activation of the breakaway device. Therefore it is critical that breakaway supports not be located in ditches, on steep slopes or in similar situations where a vehicle is likely to be partially airborne at the time of impact.

7.8 Sign assembly

All brackets and fittings applicable to a modular *Matched Component System* shall be supplied and installed in accordance with the manufacturer's recommendations to ensure tightness throughout the life of the sign.

8. INSPECTION SURVEYS

The TCD Rule Part 1: Section 3 *General requirements for traffic control devices*, outlines the general requirements for traffic signs, including that they must be safe, display clear and consistent messages and be maintained in good repair.

Regular maintenance is necessary to ensure that traffic signs continue to provide clear messages and visual cues to drivers.

Such inspection and maintenance of traffic signs should be undertaken during both day-time and night-time to ensure all traffic signs are visible and effective in all conditions. The survey team must ensure they operate the survey with the appropriate Traffic Management plan.

Typically inspection surveys will be attended by the maintenance contractor with a member of the road controlling authority or their chosen representative.

These surveys will not actually stop at each sign. Typically they will take the form of a drive through a section of road at posted, or such other speed that is deemed safe, respectful of the motoring public, whilst affording suitable time to adequately appraise the condition of the signs in the direction of travel.

Both day and night surveys are required to be carried out under Temporary Traffic Management and will usually take the form of a Mobile Operation. Furthermore the survey team will need to ensure compliance with the Road Controlling Authorities Corridor Access requirements.

The survey team must also question the relevance of traffic signs in the survey. For example; does a current curve warning speed sign remain relevant after a change to the posted speed limit.

8.1 Daytime surveys

The daytime survey must look at the overall physical condition of the sign and the sign installation checking such items as:

- (a) The actual sign face is free of environmental soil such as mildew or lichen growth
- (b) No physical damage has affected or risked sign face readability and or sign integrity
- (c) No vegetation or other structure impedes line of sight or visibility to the sign face
- (d) The sign is free of any graffiti or the aftermath of previous poor cleaning action
- (e) Sign supports and foundations are sound and maintain correct sign presentation
- (f) The need for the sign still exists – for example a speed reduction has not negated the need for a posted curve warning speed
- (g) Confirming that the physical sign and its structure remain *suitable for purpose* or note that some repair should be undertaken
- (h) Any fluorescent sign, deemed to require a higher level of day time visibility through its fluorescing colour feature, maintains a satisfactory performance e.g. Signs for active users (schools, pedestrians, cyclists).

Any individual traffic sign thought to be less than satisfactory should be reported and may require a stationary examination at which time a corrective maintenance plan can be agreed.

8.2 Night time surveys

The night time survey must follow the same general methodology as the day time survey however the focus will be on the retroreflective performance of the traffic sign. The drive through will be with head lights set in the “dip” position. This will ensure the traffic sign performs at this light level, critical for poor weather conditions and visibility against the headlights of an approaching vehicle. Hi-beam excess brightness risks presenting an artificial level of visibility which is not available in common travel conditions.

The speed of travel needs to be such that the survey enables a suitable time to view the sign at distance and then check readability throughout the approach. It is possible that some form of Temporary Traffic Management may be required for the night survey.

The night survey should identify that:

- (a) Overall any sign or part of a traffic sign (eg guide sign), especially when set in a disadvantaged position, is performing *suitable for purpose*, exhibiting an even level of retroreflectivity across the face of the sign to ensure that an appropriate level of readability is achieved across the entire sign throughout the approach
- (b) The orientation of the sign face is such that no specular (mirror) retroreflection creates an over bright glare effect that interferes with sign recognition/readability
- (c) At the threshold of retroreflectivity the traffic sign presents a level of visibility that ensures a driver becomes aware the sign is present – before actual readability is possible
- (d) That any previous maintenance completed during daylight hours has not damaged retroreflectivity at night – for example poor graffiti cleaning
- (e) Traffic signs remain fully effective and *suitable for the purpose* for which they were installed

9. MAINTENANCE AND CLEANING

Frequent cleaning will maintain sign faces in better condition than infrequent attempts to remove substantial accumulations of dirt. In industrial areas and on roads with high traffic volume where the dirt may be greasy and more adherent, frequent cleaning is essential.

The frequency of replacement and cleaning of traffic signs, along with the repainting of sign supports (where applicable) is dependent on a number of factors including traffic and environmental conditions within a local area. RCAs should develop their own guidelines and policies relating to traffic sign maintenance for their local situation.

The surface of the sign face material must be capable of having road dirt and grime readily removed from it. Signs must be cleaned according to the retroreflective sheeting manufacturer's recommendations in a manner and frequency that maintains any sign warranty and the recommended requirements of the maintenance contract.

Materials that meet NZTA M25 have been tested to withstand a reasonable range of cleaning substances and techniques.

9.1 Cleaning substances

In maintaining retroreflective traffic signs, it is important that the maintenance contractor is knowledgeable of how the sign face and sign legend is manufactured, because some legends and background colours can be easily damaged by poor cleaning methods and/or the use of an inappropriate cleaning solutions.

Rule

Old scratchy cleaning cloths and abrasive cleaners should never be used

For example, abrasive cleaners must never be used because the resultant damage to the high gloss surface will severely damage night time retroreflectivity. Equally old used cleaning cloths must be avoided since they can develop an abrasive feature.

Non-approved or aggressive solvent-based cleaning products or abrasive products used on signs can destroy the clear coating and therefore reduce the retroreflective properties of the sign sheeting. Use of approved cleaning products and methods is required in all instances for warranty reasons.

Signs should first be flushed with clean water to remove loose dirt particles that can scratch the sign surface with a soft brush or sponge using clean water with a few drops of detergent. Signs should always be washed from the top down.

Tar, oil, crayon, lipstick, diesel smut and bituminous material can be removed with mild solvents, in accordance with the sign manufacturer's recommendations. Avoid screen-processed areas (Refer Figure 9.1).

When cleaning, try the least harmful method first, gradually working towards using harsher cleaners that are more likely to damage the retroreflectivity. Test on a small corner of a sign first.

Cleaning substances from the least harmful to the most aggressive are:

- (a) Water. This may be used with some detergents
- (b) ISO Propyl alcohol. IPA. This is particularly good for removing light greasy substances.
- (c) Citrus cleaner either in aerosol form or as a liquid. This substance can be very good for removing residual adhesives after removing graffiti stickers.
- (d) Kerosene or mineral spirits. Use with care on screen printed signs.
- (e) Lacquer thinners – using this may damage the sign so use should be for very accurate cleaning ⁽⁶⁾.
- (f) Methyl Ethyl Ketone – MEK ⁽⁶⁾. This substance will almost certainly damage the sign. It is a last recourse substance to be used on the basis that it may help but if not the sign would be rubbished anyway.

After the use of any of these cleaning substances the area should be washed down with water and maybe a little detergent to remove microscopic remains of grime and cleaner residue that will harm night time retroreflectivity.

9.2 Recognising sign face sheeting components

The contractor must have the ability to recognise traffic sign face components and understand what cleaning methods must be used in each instance. If unsure a recommendation should be sought from the sign manufacturer or retroreflective sheeting manufacturer.

Rule	<i>Use the correct cleaning method for differing sign face materials; ink screen print, sign with graffiti overlay etc</i>
-------------	--

For example many cleaning fluids other than light detergent and water risk removing a screen printed legend from the sign where overlay films are more robust to a wider range of cleaning solutions.

It is equally important that sign cleaning be completed according to the retroreflective sheeting manufacturer’s recommendation in order to maintain sign warranty conditions.

The traffic sign face will most commonly be retroreflective sheeting with the legend and/or background colour created by:

- (a) The addition of transparent or opaque screen printed inks. Test with a finger nail – it will smoothly cross from one colour to the other. (Figure 9.1)

Examples include (but are not limited to)
<i>Red transparent ink for Stop signs; Blue for Keep Left signs</i>
<i>Black opaque ink legend for permanent warning signs</i>

Cleaning screen printed traffic signs must be completed with considerable care using water, with a little detergent. Frequently this will fail to restore the sign which then must be removed and

scrapped. A sign with graffiti film added can be cleaned using stronger cleaners, such as kerosene or mineral spirits, resulting in a sign that can be recovered for continued use.

- (b) The application of a coloured transparent overlay sheeting or black opaque vinyl film. Test gently with a finger nail – it will catch at the edge of the colour change. (Figure 9.1)

Examples include (but are not limited to):

Background colour of guide signs and street name signs

Black legend on permanent warning yellow signs or portions of some regulatory signs

Figure 9.1 Field check to find overlay film legend

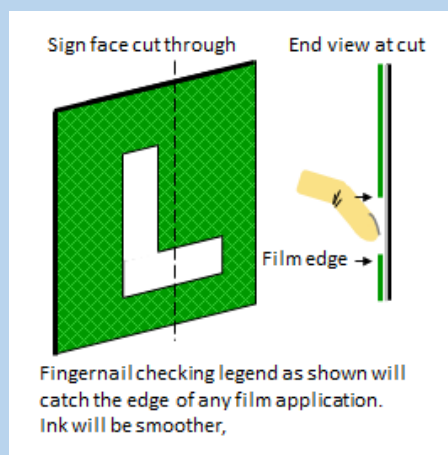

- (c) The legend and background are both created by a digital printer where the ink may be overlaid with clear, protective overlay sheeting. A finger nail check will find a smooth surface with no visible “tenting”. (Clause 9.3 Figure 9.2)

9.3 Cleaning protective overlays

After traffic sign face manufacture one of two additional protective layers may be applied to the sign. An indication that one has been applied is to look for “edge tenting” – the captured airspace at the edge of a film legend or smooth edge that can’t even find an ink line. (Figure 9.2)

- (a) Anti-graffiti overlay

Typically this film will be applied to regulatory and permanent warning signs in graffiti prone areas to enable the traffic sign face to be cleaned with the use of a wider range of cleaners.

If screen printed signs are being installed in graffiti common areas adding graffiti film is a wise precaution.

(b) Dew reduction overlay

This application must only be used on overhead guide signs or on other ground mounted guide signs that cannot be reached by graffiti vandals.

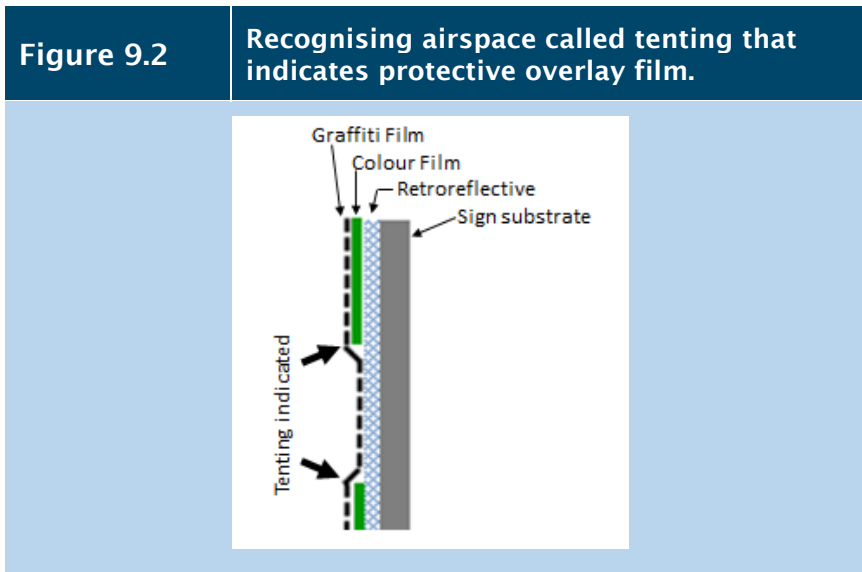

Dew reduction overlay sheeting cannot be cleaned in the normal way. In such instances it is critical to seek information from the sign manufacturer.

Rule	<i>Special handling installation and cleaning instructions must be confirmed</i>
-------------	--

Addition of these protective overlay materials does have a slight effect on sign performance but not enough for an approaching driver or survey team to notice. Only one alternative can be applied to any one traffic sign.

Rule	<i>Only one protective overlay film type may be used on any one sign</i>
-------------	--

These overlays will create some added cost to sign manufacture but this is offset against added sign performance and durability. Application of graffiti film can negate the need to replace a sign immediately after graffiti appears by enabling it to be successfully cleaned several times or, in dew prone conditions, where the traffic signs performance can be dramatically reduced, dew film will maintain the signs retroreflective function.

9.4 Maintenance of sign substrates, supports and foundations

During the traffic sign survey it is important to recognise any damage to the sign itself to ensure that the traffic sign is still correctly orientated and that any dents in the substrate will not lessen the performance of the sign. Note if a sign has moved on its support or if it has previously been poorly installed. For example, a Belisha disc that is partly obscured from one approach by being set too low on the post support.

Note must be made of the condition of the sign support(s) and the foundations. Sign supports should be cleaned, repainted, straightened or replaced to ensure that the sign maintains the “*general requirements for traffic signs, including that they must be safe, display clear and consistent messages and be maintained in good repair*”.

9.5 Maintenance performance degradation/sign life

Performance degradation of traffic signs occurs with normal ageing but varies considerably relative to the technology of the retroreflective sheeting and environmental factors.

Traffic sign maintenance is essential for traffic sign durability, maintenance of traffic sign warranties and to prevent premature aging caused by pollen and lichen damage.

Road controlling authorities must ensure that traffic signs are maintained, especially in areas where the road environment may prematurely damage performance.

However, all material will degrade with time and there will come a point at which the traffic sign will become ineffective and no longer *suitable for purpose*.

Maintenance contractors must be aware of signs that are visibly less than satisfactory in both daylight and under night time retroreflectivity.

Each RCA will establish their own process for the replacement of old non-performing signs that are no longer *suitable for purpose*.

The day and night sign surveys must identify such signs, note the sign age from the sign manufacturer's label on the back, identify the sign sheeting Class and sign face components (screen ink, colour overlay etc) and report the sign to the RCA.

10. SIGN REPLACEMENT

Detailed information on performance degradation and minimum coefficients of luminous intensity (R_A) of traffic signs can be found in part 10 of the Austroads *Guide to traffic management*.

During the night time inspection the survey should not be required to physically check the retroreflective performance value (R_A) of every traffic sign since this would take considerable time. Instead the members on the survey must agree that a traffic signs night time performance remains 'suitable for purpose'.

If the contractor or any member of the inspection team believes or is concerned that a traffic sign is *less than satisfactory* then that traffic sign should be noted and a request filed for the level of retroreflectivity (R_A) to be measured or verified using a hand held or mobile retroreflectometer.

Prior to this measurement being taken the traffic sign should be checked for surface contaminants. If necessary the traffic sign face should be cleaned before measurements are taken. If environmental soiling is a cause for concern the site should be logged as a special routine maintenance requirement.

10.1 Minimum retroreflective performance

The level of retroreflectivity below which an RCA decides that replacement becomes necessary is up to each RCA but an option is to select an R_A value that represents a specific known value set. If this is not written into a contract the maintenance contractor must review this methodology with the RCA.

Deciding upon the day-time suitability of a sign is relative to visible day-time recognised factors. Substrate damage, foundations, post condition, sign colour and cleanliness are all visible and should have a set condition standard specified, failure of which requires a sign to be cleaned, repaired or replaced.

However, checking the level of retroreflective performance for every sign within a network every year cannot be cost justified. The level of retroreflective performance (R_A) below which an RCA decides that replacement becomes necessary is up to each RCA, but an option is to select an R_A value that represents a specific known value set.

As an example, the minimum retroreflective performance level could be specified as being *50% of the rated value of Class 300 sheeting* as shown in Table 10.1.

Table 10.1		AS 1906.1 (Previously AS/NZS 1906.1) R_A New and at 50% of Class 300 measured at $\alpha=0.2^\circ$ $\beta=4.0^\circ$						
COLOUR	White	Yellow	Red	Dark Green	Blue	Brown	NZ Green	Orange
NEW	250	170	45	20	20	12	45	100
50%	125	85	22.5	10	10	6.0	22.5	50

With this set as a minimum R_A value, it should not infer that all signs must be replaced if not above this level. It does specify that, when a traffic sign is judged, during a survey, to be less than "satisfactory for purpose", and it is less than the set minimum performance value, then replacement is required.

The minimum retroreflective value for the RCA therefore becomes a combination of being judged *suitable for purpose* in that specific site, which could be a disadvantaged position, coupled with the *retroreflective value* R_A . Other signs could be less than the 50% but remain well *suitable for purpose* in a better site.

When the measured retroreflective value falls below the specified value, requiring a sign to be replaced, the original installation dates should be checked against any sign manufacturer's warranted condition.

In situations where one sign of a combination is to be replaced, for example a permanent warning sign with a supplementary sign plate, a decision should be requested from the RCA regarding replacement of both traffic signs especially if the remaining sign is showing noticeable signs of aging.

10.2 Apparent sign over brightness

This phenomenon can occur when a new or relatively new traffic sign is viewed in clear night time conditions, typically under high beam lights. Hence the receiver of the complaint must confirm high or low beam.

If the complaint is subsequent to high beam lights the contractor or RCA may comment that "traffic signs must also be seen in less than ideal, possibly inclement wet conditions with low beam lights, and or viewed against approaching headlights". This can result in a sign seeming to be over-bright in good conditions with lights on high beam but importantly remain effective in difficult circumstances.

Adding that "initial performance is part of traffic sign life where performance is expected to continue, through a variety of conditions, for typically, fifteen maybe 20 years despite environmental aging, soil and sun damage. The sign is new and the installation has been checked. It should reduce as weather film forms in the coming months.

However this type of complaint may be identifying a sign that has been installed incorrectly – potentially not at 5 degrees away from approaching traffic and the complainant is identifying specular glare that dazzles a driver making the sign over bright and difficult to read (Figures 7.3 and 7.4).

A contractor should be alerted to check the sign placement. (Refer "tip" Figure 7.8)

10.3 Temporary sign covering

If it is necessary to temporarily cover a permanent sign face following installation or when subsequent road work is being completed, the covering must not cause permanent damage to the sign face potentially negating sign warranty or damaging sign performance.

It is recommended that any method used is approved by the sign manufacturer. Porous cloth covers, which are folded over the sign edges and secured at the back of the sign leaving space for the sign to breathe and avoid moisture build up, are recommended.

Do not use paper, plastic sheet, metal covers or any adhesive tape that is not approved by the sign manufacturer. A highly specialised low tack tape can be used in some circumstances but this should be limited to such material that is available from the sign manufacturer or retroreflective sheeting manufacturer.

APPENDIX A

STIFFENING OF ALUMINIUM PANELS

For Permanent Warning and Regulatory signage

Notes Relating to Use of Drawings

These Figures provide guidance as to how to apply accepted aluminium stiffening extrusions on four common sign shapes manufactured using accepted aluminium sign substrate panels.

Note: Small Channel stiffening extrusion: 18.2 mm wide
 Medium Channel stiffening extrusion: 24.5 mm wide
 Channel stiffening extrusion end to edge of panel 50±3mm measured at centre to edge

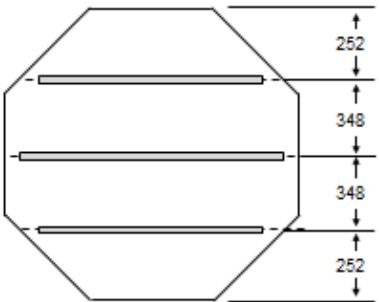
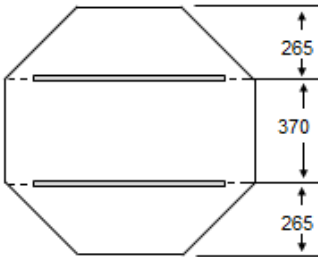
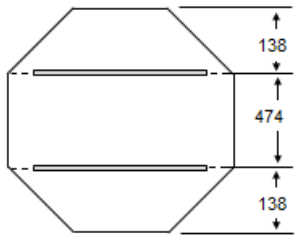
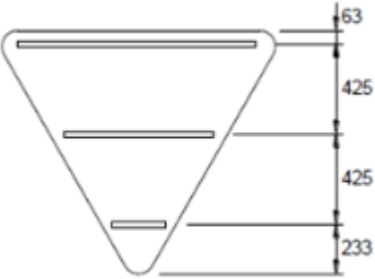
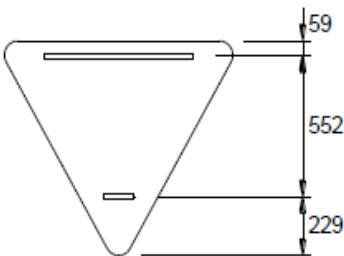
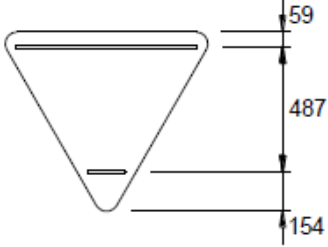
A	RP1 Regulatory – Priority Stop Signs (RG5) (Rule R2-1)	
		
1200mm (Medium Channel)	900mm (Small Channel)	750mm (Small Channel)
B	RP2 Regulatory – Priority Give Way Signs (RG6)	
		
1200mm (Medium Channel)	900mm (Small Channel)	750mm (Small Channel)
C	Permanent Warning Sign Diamonds	

<p>1200 x 1200mm (Medium Channel)</p>	<p>900 x 900mm (Small Channel)</p>	<p>750 x 750mm (Small Channel)</p>
		<p>600 x 600mm (Small Channel)</p>

D	Circular Signs		
<p>1200mm dia. (Medium Channel)</p>	<p>900mm dia. (Small Channel)</p>	<p>750mm dia. (Small Channel)</p>	
		<p>600mm dia. (Small Channel)</p>	<p>400mm dia. (Small Channel)</p>

APPENDIX B

SIGN SUPPORT SELECTION CHARTS FOR SMALL SIGNS

B1 Notes Relating to Use of Charts

The charts in this appendix can be used for the selection of typical sign support sizes for small signs (sign panel area less than or equal to 4.7m²) located at the roadside. The following notes apply:

- (a) **Charts are based on open terrain (Terrain Category 2) with gentle topography ($M_h = 1.0$).**
A conservative approach for signs in hilly terrain (with slopes up to 1 vertical to 5 horizontal), is to multiply the sign area by 1.35 before entering the chart to select the sign support sizes required. If in shadow lee zones, or areas of known channelling, multiply the sign area by 1.8 before entering the chart. For more severe topography, or a less conservative approach, specific design is required.
- (b) For sign supports in terrain category 3 the sign area may be multiplied by 0.8 before entering the chart to select the support sizes required.
- (c) A structure importance level of 1 has been used, with an annual probability of exceedance for ultimate limit state for wind loading of 1/50.
- (d) A drag force coefficient of 1.5 has been applied, ($C_d = 1.5$).
- (e) The charts are for single support installations. For multiple support installations refer to Section B1.1.5. below
- (f) Design to AS/NZS 1170.2 is required for signs at an elevation greater than 500m above sea level.

B1.1 How to Use the Charts

- (a) Select the appropriate wind speed for the given sign location. The charts for the regional wind speed of 45m/s apply to Wellington and the Marlborough Sounds, (Region W). The charts for a regional wind speed of 39m/s apply to all other regions, (Regions A6 & A7).
- (b) Consider the local topography as outlined in Section B1 (a) above and adjust sign area to be entered if necessary.
- (c) Select the appropriate post type, (Section B1 (b) of this appendix lists the types covered by these charts).
- (d) For single support installations select the appropriate sign area (A) and follow the chart across to find the intercept with the required sign height (H) measured from ground level to the centre of the sign panel. The section size required is the one for the curve above this point of intersection.
- (e) For multiple support installations the required sign area (A) must be multiplied by $(1.15/n)$ before entering the chart, where n is the number of supports to be used.

B1.2 List of Charts Included in this Appendix

Support Selection Chart for Basic Wind Speed

Chart number B1	Sign Support type*	Wind speed
1	Timber Post* (Radiata No.1)	39m/s
2	Aluminium CHS Pole* (255 MPa)	39m/s
3	Steel CHS Pole* (G350)	39m/s
4	Steel RHS Pole* (G350)	39m/s
5	Timber Post* (Radiata No.1)	45m/s
6	Aluminium CHS Pole* (255 MPa)	45m/s
7	Steel CHS Pole* (G350)	45m/s
8	Steel RHS Pole* (G350)	45m/s

* Refer to Clause 3. Definitions; Sign support

CHART B1

Timber (Radiata No.1) Post Selection Chart for Regional Wind Speed of 39m/s (Region A for Average Recurrence Interval of 50 Years & Importance Level of 1 (AS/NZS 1170))

[ULS Pressure (F) = 1.13kPa at <5m, Terrain Category 2]

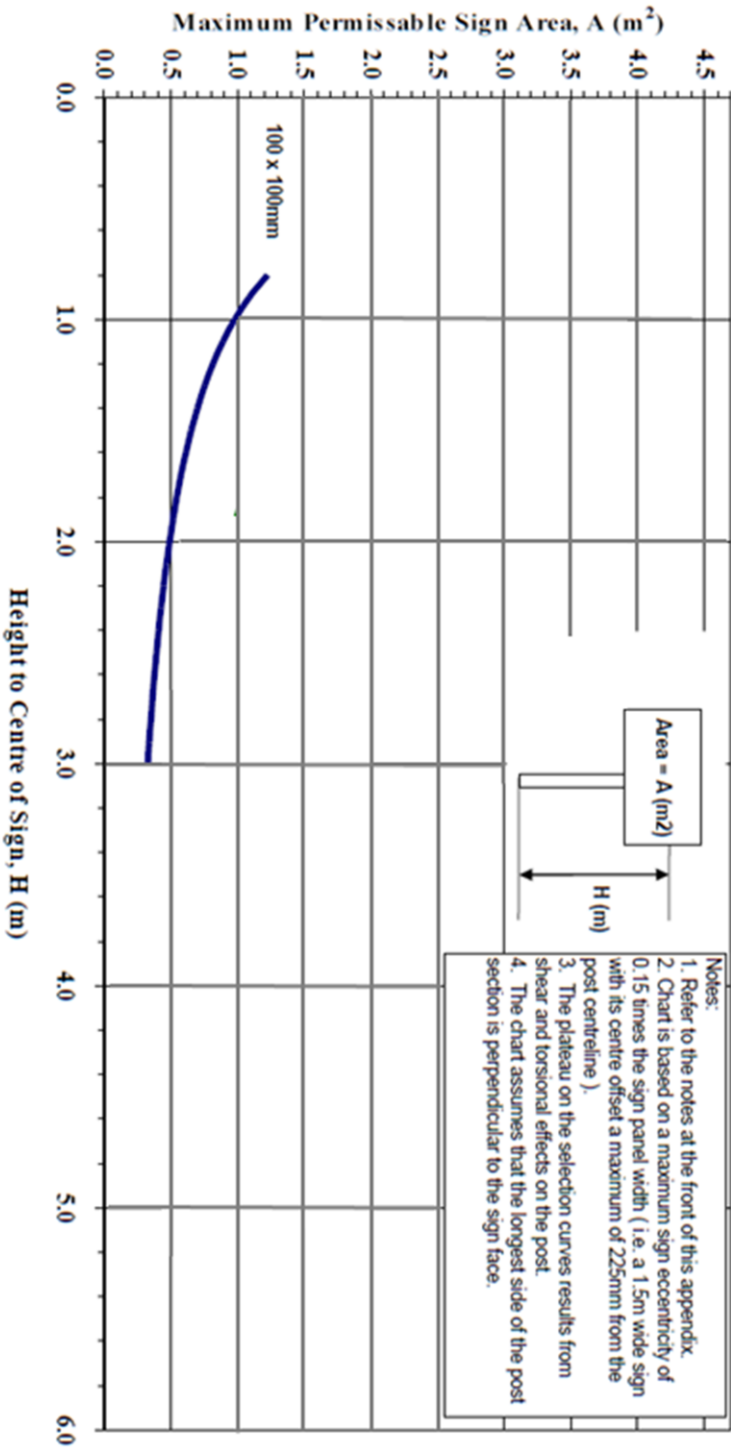

CHART B2

Aluminium CHS (255MPa) Pole Selection Chart for Regional Wind Speed of 39m/s (Region A for Average Recurrence Interval of 50 Years & Importance Level of 1 (AS/NZS 1170))

[ULS Pressure (F) = 1.13kPa at <5m, Terrain Category 2]

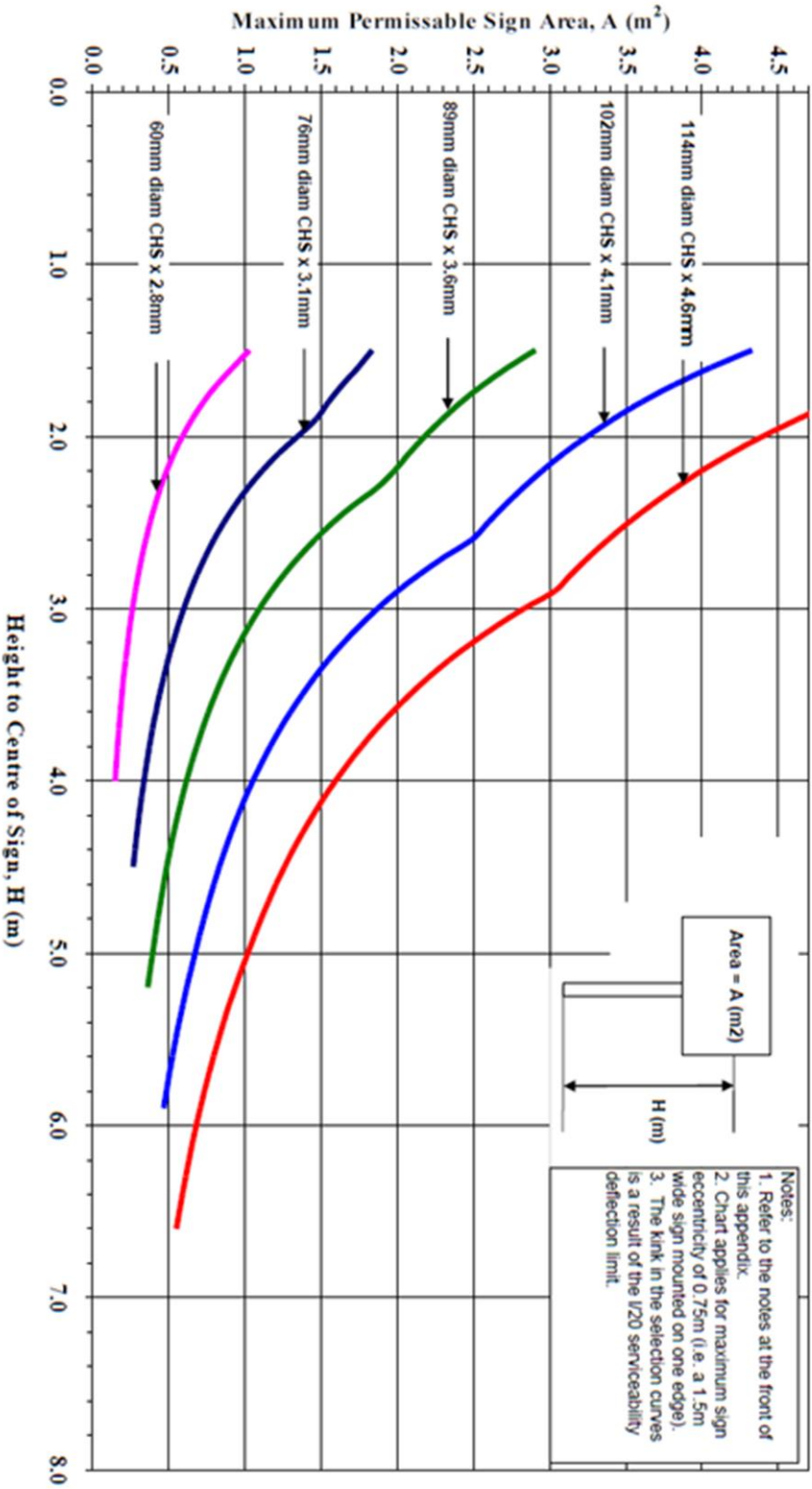

CHART B3

Steel CHS (G350) Pole Selection Chart for Regional Wind Speed of 39m/s (Region A for Average Recurrence Interval of 50 Years & Importance Level of 1 (AS/NZS 1170))

[ULS Pressure (F) =1.13kPa at <5m, Terrain Category 2]

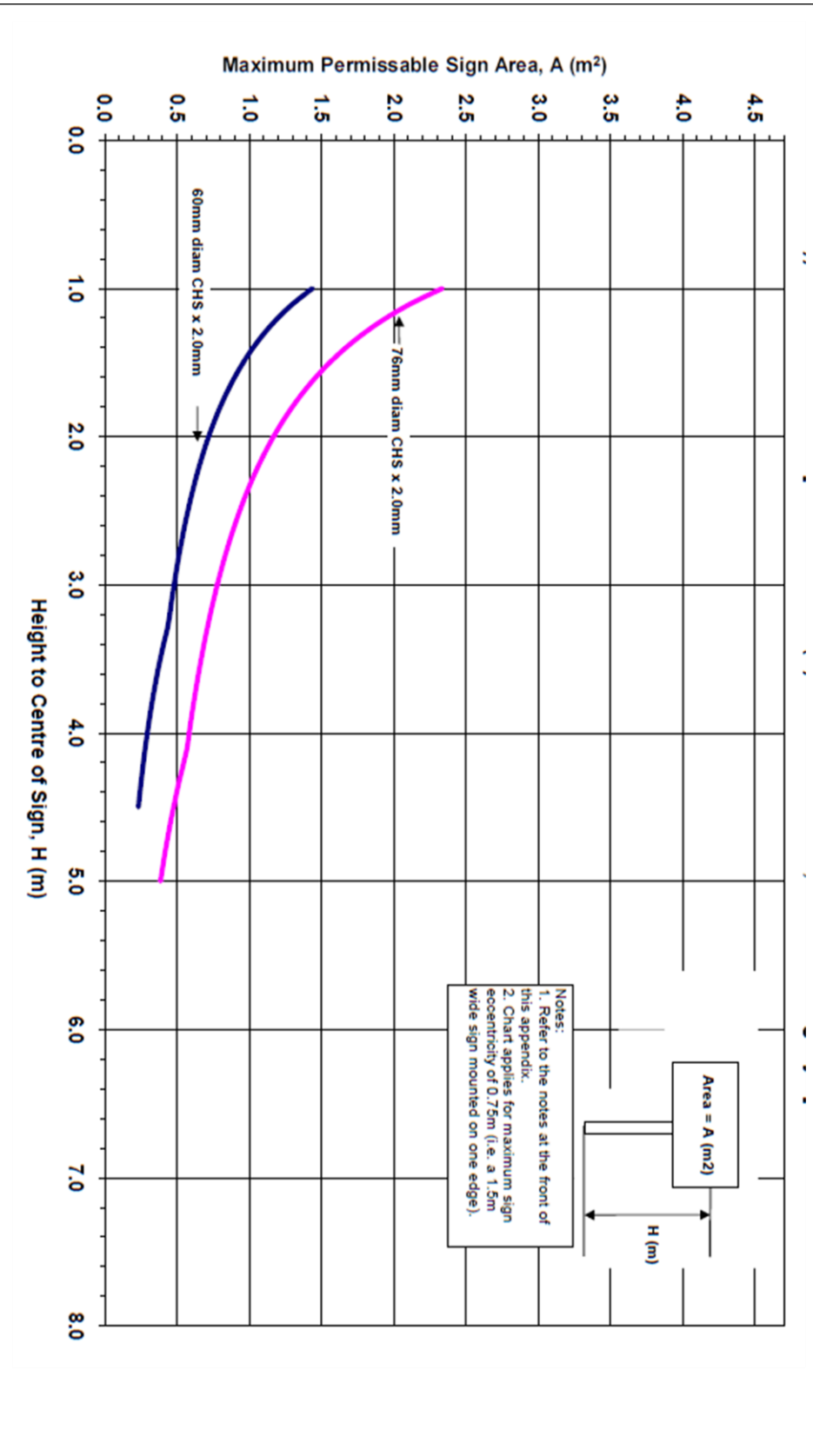

CHART B4

Steel RHS (G350) Pole Selection Chart for Regional Wind Speed of 39m/s (Region A for Average Recurrence Interval of 50 Years & Importance Level of 1 (AS/NZS 1170))

[ULS Pressure (F) = 1.13kPa at <5m, Terrain Category 2]

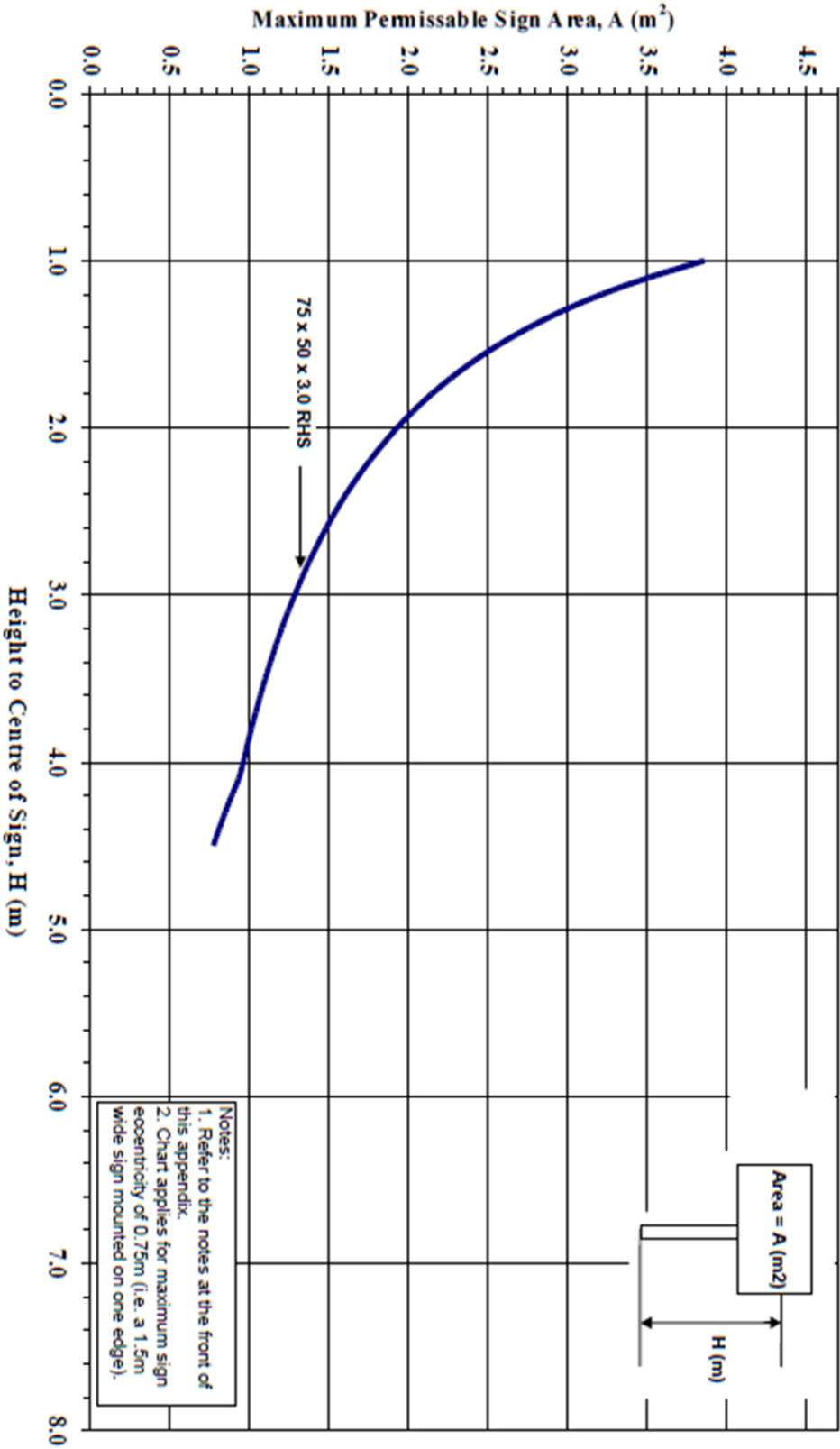

CHART B5

Timber (Radiata No.1) Post Selection Chart for Regional Wind Speed of 45m/s (Region W for Average Recurrence Interval of 50 Years & Importance Level of 1 (AS/NZS 1170))

[ULS Pressure (F) =1.51kPa at <5m, Terrain Category 2]

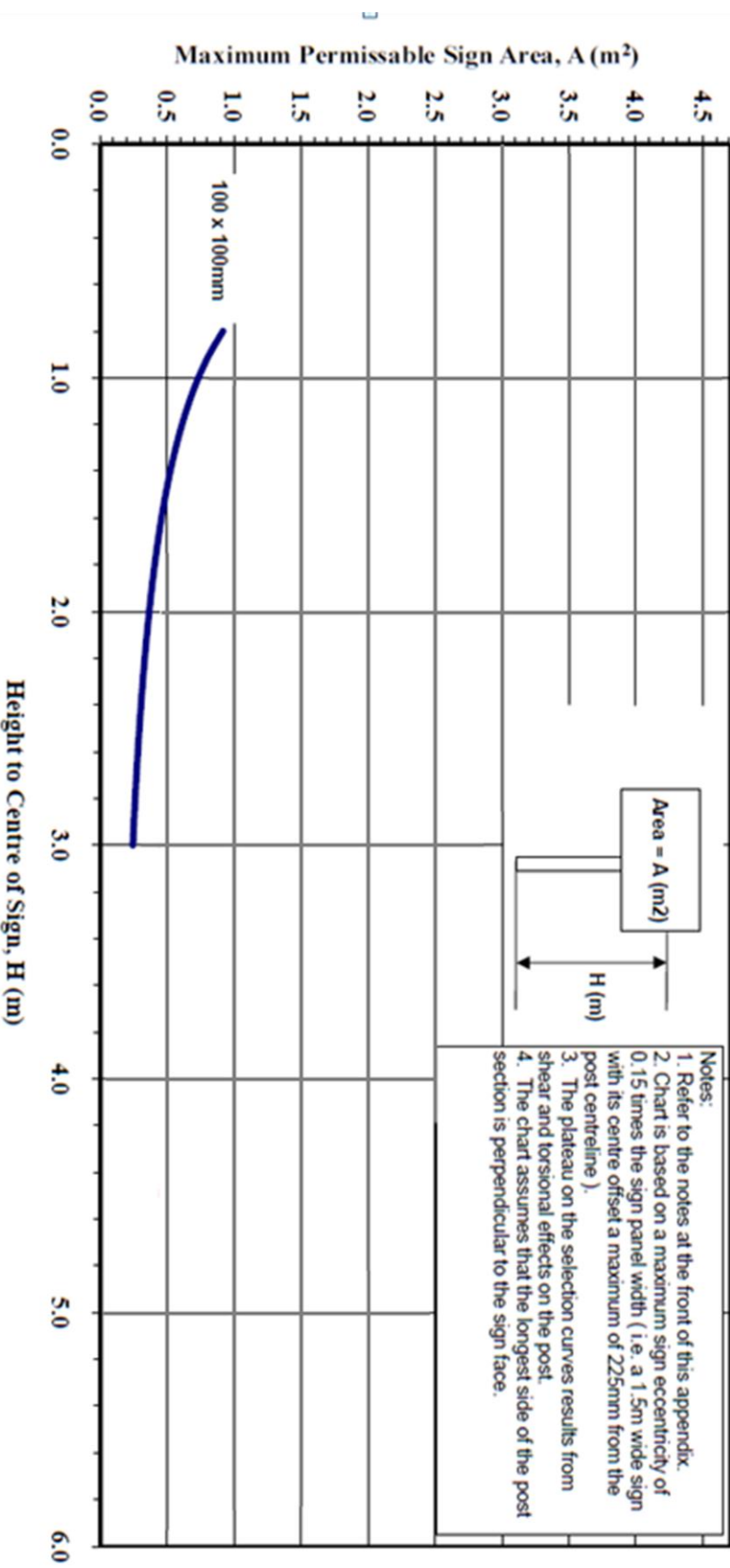

CHART B6

Aluminium CHS (255MPa) Pole Selection Chart for Regional Wind Speed of 45m/s (Region W for Average Recurrence Interval of 50 Years & Importance Level of 1 (AS/NZS 1170))

[ULS Pressure (F) = 1.51kPa at <5m, Terrain Category 2]

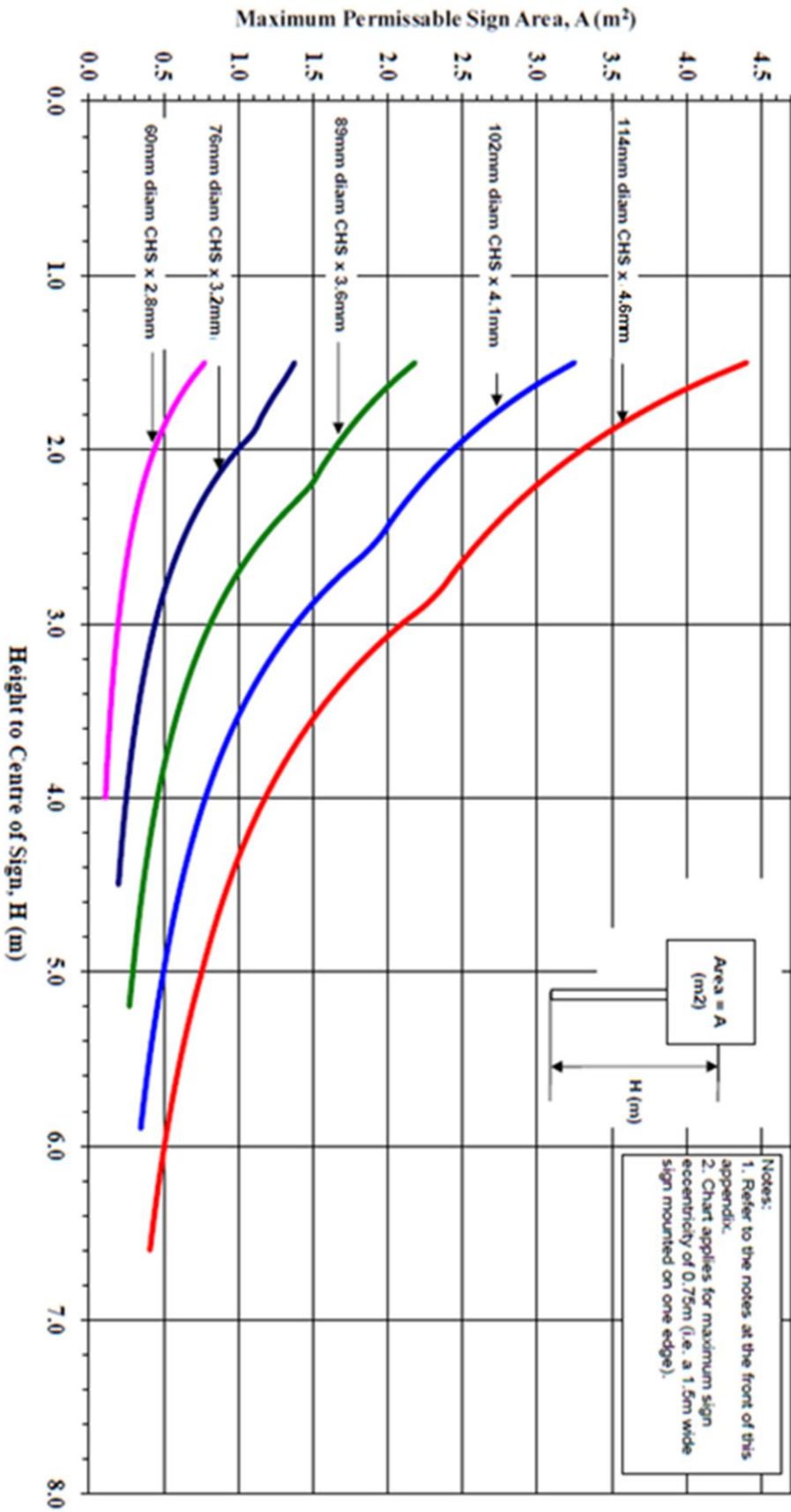

CHART B7

Steel CHS (G350) Pole Selection Chart for Regional Wind Speed of 45m/s (Region W for Average Recurrence Interval of 50 Years & Importance Level of 1 (AS/NZS 1170))

ULS Pressure (F) = 1.51kPa at <5m, Terrain Category 2]

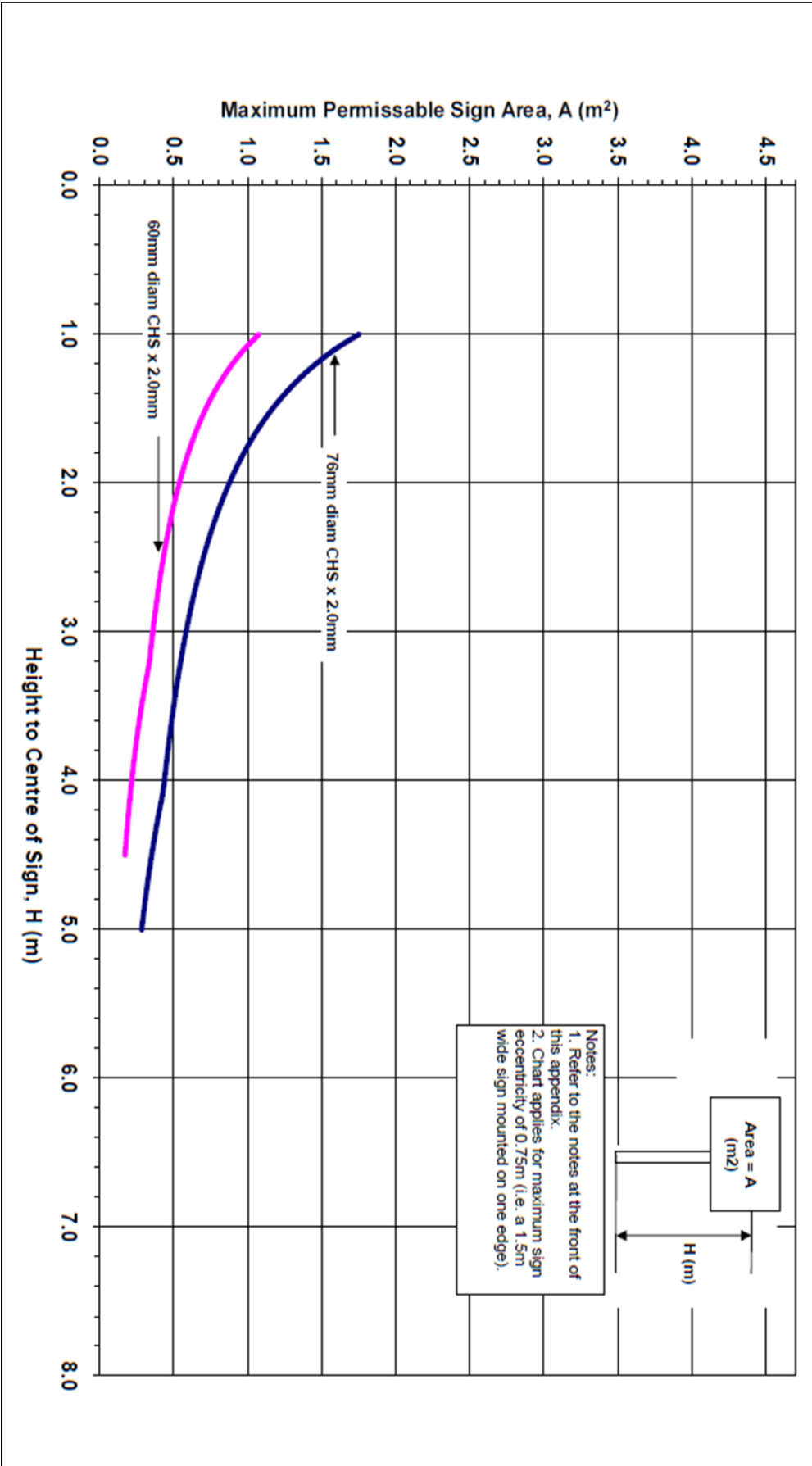
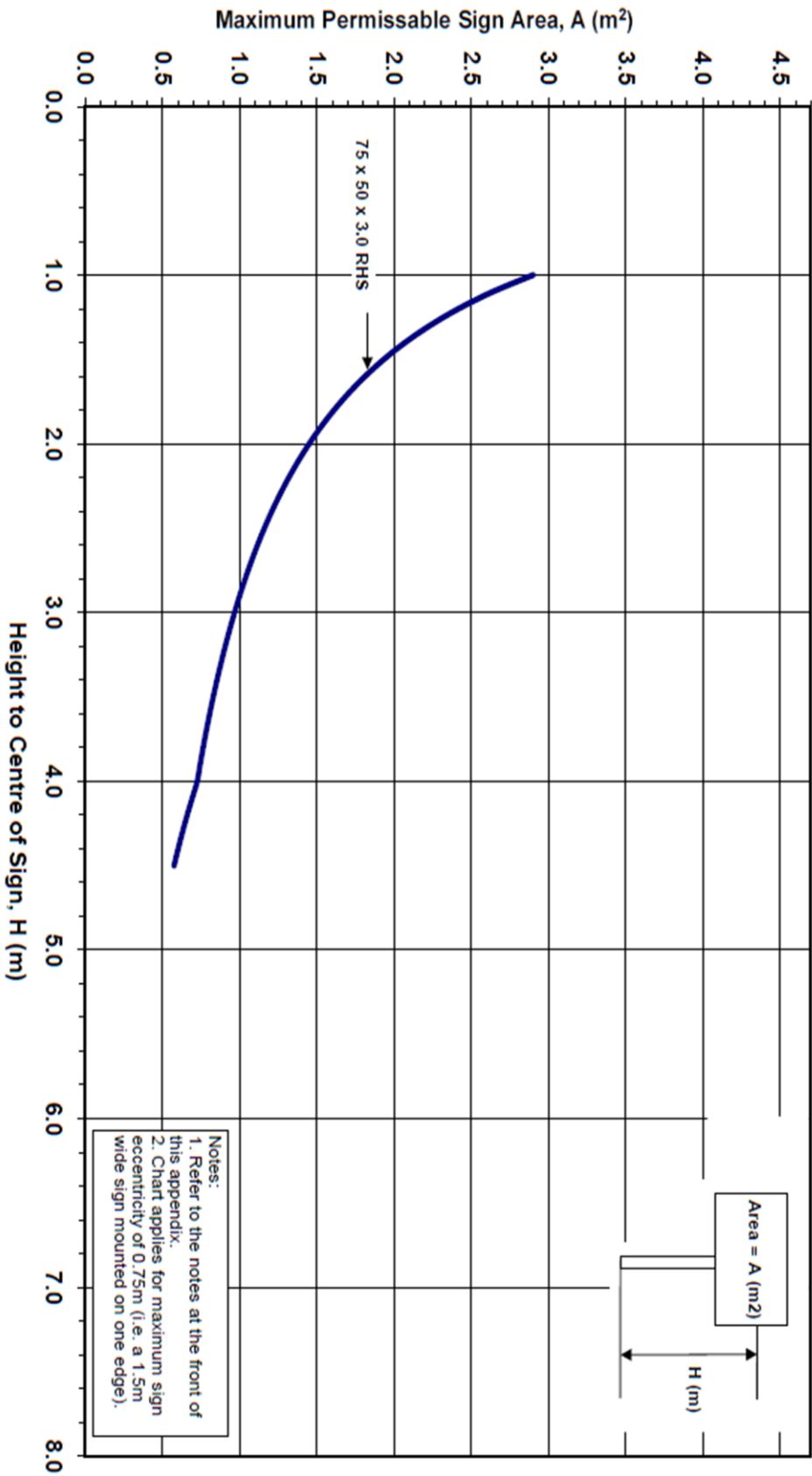

CHART B8

Steel RHS (G350) Pole Selection Chart for Regional Wind Speed of 45m/s (Region W for Average Recurrence Interval of 50 Years & Importance Level of 1 (AS/NZS 1170))

[ULS Pressure (F) = 1.51kPa at <5m, Terrain Category 2]



Notes:
 1. Refer to the notes at the front of this appendix.
 2. Chart applies for maximum sign eccentricity of 0.75m (i.e. a 1.5m wide sign mounted on one edge).

APPENDIX C

FOUNDATION SELECTION TABLES FOR SMALL SIGNS

C1 Notes Relating to Use of Tables

The tables in this appendix give the required depth of embedment (L) for cylindrical foundations for a range of applied forces and sign heights. These tables have been derived using Broms theory. A table for shallow pad foundations has also been included for situations where underground services are present. The following notes apply:

- (a) Topsoil, very soft or very loose surface sediments shall not be included in the embedment depths given in the tables.
- (b) Soil type should be assessed from appropriate investigation.
- (c) Specific design is required if the groundwater level is above the base of the foundation.

C1.1 How to Use the Tables

- (a) Evaluate the soil conditions for the given sign location. Section C1.3 of this appendix gives typical properties and the appropriate foundation selection table for a range of soil types. If soil conditions are not known Table C1 may be used.
- (b) If a shallow pad foundation is required in areas with underground services Table 16 can be used to size the pad.
- (c) Calculate the force on the sign panel using Sign Area (A) x Ultimate Limit State wind pressure (F), given on the sign support selection charts.
- (d) Enter the left-hand column of the foundation selection table and select the appropriate value of $F \times A$.
- (e) Follow the row across to the appropriate column for the height of the sign (measured from ground level to the centre of the sign panel).
- (f) Read off the required depth of embedment which is given in metres.

C1.2 Typical Soil Parameters for Table Selection

These parameters are based on values from J.E. Bowles, Foundation Analysis and Design, Third Edition, McGraw Hill, 1984 and NZ Geomechanics Guidelines for Field Descriptions of Soils and Rocks in Engineering Use. The foundation selection tables are generally based on soil properties at the lower bound of those indicated below.

A) Cohesionless Soil (Gravels and sands)

Soil	Friction angle ϕ degrees	Table to use
Loose	27-32	C5
Medium Dense	30-39	C5
Dense	35-43	C6
Very Dense	>38	C6

Typical friction angles for sands are nearer the low end of the ranges quoted above while typical values for gravels are near the high end of the ranges quoted.

B) Cohesive Soil (Silts and Clays)

Soil State	Undrained shear strength S_u (kPa)	Table to use
Soft	25-50	C1
Firm	50-100	C2
Stiff	100-200	C3
Very Stiff/Hard	>200	C3

C) Rock

State	Parameter	Table to use
Un-weathered to moderately weathered, strong to very strong rock with closely spaced defects.	$\phi = 45$ degrees	C7
Un-weathered, very weak rock with widely spaced defects (highly fractured).	$S_u = 500$ kPa	C4

C1.3 List of Tables Included in this Appendix

Table: Description:

Table No.	Description
C1	Cylindrical Sign Support Foundations - Unknown soil conditions
C2	Cylindrical Sign Support Foundations - Cohesive soil with $S_u = 50$ kPa
C3	Cylindrical Sign Support Foundations - Cohesive soil with $S_u = 100$ kPa
C4	Cylindrical Sign Support Foundations - Un-weathered rock with $S_u = 500$ kPa
C5	Cylindrical Sign Support Foundations - Cohesion less soil with $\phi = 30$ degrees
C6	Cylindrical Sign Support Foundations - Cohesion less soil with $\phi = 35$ degrees
C7	Cylindrical Sign Support Foundations - Strong un-weathered rock (highly fractured) with $\phi = 30$ degrees
C8	Shallow Pad Foundations - Cohesion less soil with ϕ not less than 30 degrees and cohesive soils with S_u not less than 50 kPa.

Table C1
Table of Embedment Depths (L) for Cylindrical Sign Support Foundations.

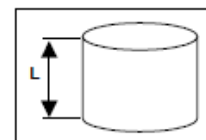

Unknown Conditions									
300mm diameter Cylindrical Concrete Foundations									
F x A (KN)	Height to Centre of Sign (m)								
	1.0	1.5	2.0	2.5	3.0	3.5	4.0	4.5	5.0
0.25	0.7	0.7	0.8	0.8	0.8	0.8	0.8	0.9	0.9
0.5	0.8	0.8	0.9	0.9	0.9	1.0	1.0	1.0	1.0
1.0	0.9	1.0	1.0	1.1	1.1	1.2	1.2	1.2	1.3
1.5	1.0	1.1	1.1	1.2	1.3	1.3	1.4	1.4	1.4
2.0	1.1	1.2	1.3	1.3	1.4	1.4	1.5	1.5	1.6
2.5	1.2	1.3	1.4	1.4	1.5	1.6	1.6	1.7	1.7
3.0	1.2	1.4	1.4	1.5	1.6	1.7	1.7	1.8	1.9
3.5	1.3	1.4	1.5	1.6	1.7	1.8	1.8	1.9	2.0
4.0	1.4	1.5	1.6	1.7	1.8	1.9	1.9	2.0	2.1
4.5	1.4	1.6	1.7	1.8	1.9	2.0	2.0	2.1	2.2
5.0	1.5	1.6	1.7	1.9	1.9	2.0	2.1	2.2	2.3
5.5	1.6	1.7	1.8	1.9	2.0	2.1	2.2	2.3	2.4
6.0	1.6	1.8	1.9	2.0	2.1	2.2	2.3	2.4	2.5
6.5	1.7	1.8	1.9	2.1	2.2	2.3	2.4	2.5	2.6
7.0	1.7	1.9	2.0	2.1	2.2	2.4	2.5	2.5	2.6
7.5	1.8	1.9	2.1	2.2	2.3	2.4	2.5	2.6	2.7

400mm diameter Cylindrical Concrete Foundations									
F x A (KN)	Height to Centre of Sign (m)								
	1.0	1.5	2.0	2.5	3.0	3.5	4.0	4.5	5.0
0.25	0.7	0.7	0.7	0.7	0.8	0.8	0.8	0.8	0.8
0.5	0.7	0.8	0.8	0.8	0.9	0.9	0.9	0.9	1.0
1.0	0.9	0.9	0.9	1.0	1.0	1.1	1.1	1.1	1.2
1.5	0.9	1.0	1.1	1.1	1.2	1.2	1.2	1.3	1.3
2.0	1.0	1.1	1.1	1.2	1.3	1.3	1.4	1.4	1.4
2.5	1.1	1.2	1.2	1.3	1.4	1.4	1.5	1.5	1.6
3.0	1.1	1.2	1.3	1.4	1.4	1.5	1.6	1.6	1.7
3.5	1.2	1.3	1.4	1.5	1.5	1.6	1.6	1.7	1.8
4.0	1.2	1.4	1.4	1.5	1.6	1.7	1.7	1.8	1.9
4.5	1.3	1.4	1.5	1.6	1.7	1.7	1.8	1.9	1.9
5.0	1.3	1.5	1.6	1.7	1.7	1.8	1.9	2.0	2.0
5.5	1.4	1.5	1.6	1.7	1.8	1.9	2.0	2.0	2.1
6.0	1.4	1.6	1.7	1.8	1.9	2.0	2.0	2.1	2.2
6.5	1.5	1.6	1.7	1.8	1.9	2.0	2.1	2.2	2.3
7.0	1.5	1.7	1.8	1.9	2.0	2.1	2.2	2.3	2.3
7.5	1.6	1.7	1.8	1.9	2.0	2.1	2.2	2.3	2.4

NOTES:

The above Tables give the required depth of embedment (L) for cylindrical concrete sign support foundations for a range of applied forces and sign heights. These depths have been derived using Broms theory. The following notes apply:

1. Refer to the notes on table usage at the front of this appendix
2. Above foundations do not allow for eccentrically mounted signs
3. Tables assume that supports are embedded to within 100mm of the bottom of the foundation, or a steel/aluminium sleeve (with end cap) to take the support is cast to within 100mm of the bottom of the foundation.

Table C2
Table of Embedment Depths (L) for Cylindrical Sign Support Foundations.

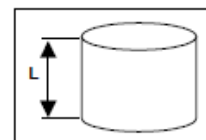

Su = 50 kPa									
300mm diameter Cylindrical Concrete Foundations									
F x A (KN)	Height to Centre of Sign (m)								
	1.0	1.5	2.0	2.5	3.0	3.5	4.0	4.5	5.0
0.25	0.6	0.7	0.7	0.7	0.7	0.7	0.7	0.8	0.8
0.5	0.7	0.7	0.8	0.8	0.8	0.8	0.8	0.9	0.9
1.0	0.8	0.8	0.9	0.9	0.9	1.0	1.0	1.1	1.0
1.5	0.9	0.9	0.9	1.0	1.0	1.1	1.1	1.1	1.2
2.0	0.9	1.0	1.0	1.1	1.1	1.2	1.2	1.2	1.3
2.5	1.0	1.0	1.1	1.1	1.2	1.2	1.3	1.3	1.4
3.0	1.0	1.1	1.1	1.2	1.3	1.3	1.4	1.4	1.4
3.5	1.1	1.1	1.2	1.3	1.3	1.4	1.4	1.5	1.5
4.0	1.1	1.2	1.3	1.3	1.4	1.4	1.5	1.5	1.6
4.5	1.1	1.2	1.3	1.4	1.4	1.5	1.6	1.6	1.7
5.0	1.2	1.3	1.4	1.4	1.5	1.6	1.6	1.7	1.7
5.5	1.2	1.3	1.4	1.5	1.5	1.6	1.7	1.7	1.8
6.0	1.2	1.4	1.4	1.5	1.6	1.7	1.7	1.8	1.9
6.5	1.3	1.4	1.5	1.6	1.6	1.7	1.8	1.9	1.9
7.0	1.3	1.4	1.5	1.6	1.7	1.8	1.8	1.9	2.0
7.5	1.3	1.5	1.6	1.7	1.7	1.8	1.9	2.0	2.0

400mm diameter Cylindrical Concrete Foundations									
F x A (KN)	Height to Centre of Sign (m)								
	1.0	1.5	2.0	2.5	3.0	3.5	4.0	4.5	5.0
0.25	0.6	0.6	0.7	0.7	0.7	0.7	0.7	0.7	0.7
0.5	0.7	0.7	0.7	0.7	0.8	0.8	0.8	0.8	0.8
1.0	0.7	0.8	0.8	0.8	0.9	0.9	0.9	0.9	1.0
1.5	0.8	0.8	0.9	0.9	1.0	1.0	1.0	1.0	1.1
2.0	0.9	0.9	0.9	1.0	1.0	1.1	1.1	1.1	1.2
2.5	0.9	1.0	1.0	1.1	1.1	1.1	1.2	1.2	1.2
3.0	0.9	1.0	1.1	1.1	1.2	1.2	1.2	1.3	1.3
3.5	1.0	1.0	1.1	1.2	1.2	1.3	1.3	1.3	1.4
4.0	1.0	1.1	1.1	1.2	1.3	1.3	1.4	1.4	1.4
4.5	1.0	1.1	1.2	1.3	1.3	1.4	1.4	1.5	1.5
5.0	1.1	1.2	1.2	1.3	1.4	1.4	1.5	1.5	1.6
5.5	1.1	1.2	1.3	1.3	1.4	1.5	1.5	1.6	1.6
6.0	1.1	1.2	1.3	1.4	1.4	1.5	1.6	1.6	1.7
6.5	1.2	1.3	1.3	1.4	1.5	1.5	1.6	1.7	1.7
7.0	1.2	1.3	1.4	1.5	1.5	1.6	1.6	1.7	1.8
7.5	1.2	1.3	1.4	1.5	1.6	1.6	1.7	1.8	1.8

NOTES:

The above Tables give the required depth of embedment (L) for cylindrical concrete sign support foundations for a range of applied forces and sign heights. These depths have been derived using Broms theory. The following notes apply:

1. Refer to the notes on table usage at the front of this appendix
2. Foundations above the solid line are satisfactory for sign eccentricities up to 0.75m (i.e. signs up to 1.5m wide mounted on one edge). Foundations below the solid line do not allow for eccentrically mounted signs.
3. Tables assume that supports are embedded to within 100mm of the bottom of the foundation, or a steel/aluminium sleeve (with end cap) to take the support is cast to within 100mm of the bottom of the foundation.

Table C3
Table of Embedment Depths (L) for Cylindrical Sign Support Foundations

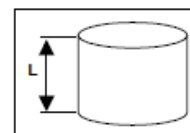

Su = 100 kPa									
300mm diameter Cylindrical Concrete Foundations									
F x A (KN)	Height to Centre of Sign (m)								
	1.0	1.5	2.0	2.5	3.0	3.5	4.0	4.5	5.0
0.25	0.6	0.6	0.6	0.6	0.6	0.7	0.7	0.7	0.7
0.5	0.6	0.7	0.7	0.7	0.7	0.7	0.7	0.8	0.8
1.0	0.7	0.7	0.8	0.8	0.8	0.8	0.8	0.9	0.9
1.5	0.7	0.8	0.8	0.8	0.9	0.9	0.9	0.9	1.0
2.0	0.8	0.8	0.9	0.9	0.9	1.0	1.0	1.0	1.0
2.5	0.8	0.9	0.9	0.9	1.0	1.0	1.0	1.1	1.1
3.0	0.9	0.9	0.9	1.0	1.0	1.1	1.1	1.1	1.2
3.5	0.9	0.9	1.0	1.0	1.1	1.1	1.1	1.2	1.2
4.0	0.9	1.0	1.0	1.1	1.1	1.2	1.2	1.2	1.3
4.5	0.9	1.0	1.1	1.1	1.2	1.2	1.2	1.3	1.3
5.0	1.0	1.0	1.1	1.1	1.2	1.2	1.3	1.3	1.4
5.5	1.0	1.1	1.1	1.2	1.2	1.3	1.3	1.4	1.4
6.0	1.0	1.1	1.1	1.2	1.3	1.3	1.4	1.4	1.4
6.5	1.0	1.1	1.2	1.2	1.3	1.3	1.4	1.4	1.5
7.0	1.1	1.1	1.2	1.3	1.3	1.4	1.4	1.5	1.5
7.5	1.1	1.2	1.2	1.3	1.4	1.4	1.5	1.5	1.6

400mm diameter Cylindrical Concrete Foundations									
F x A (KN)	Height to Centre of Sign (m)								
	1.0	1.5	2.0	2.5	3.0	3.5	4.0	4.5	5.0
0.25	0.6	0.6	0.6	0.6	0.6	0.6	0.6	0.7	0.7
0.5	0.6	0.6	0.7	0.7	0.7	0.7	0.7	0.7	0.7
1.0	0.7	0.7	0.7	0.7	0.8	0.8	0.8	0.8	0.8
1.5	0.7	0.7	0.8	0.8	0.8	0.8	0.9	0.9	0.9
2.0	0.7	0.8	0.8	0.8	0.9	0.9	0.9	0.9	1.0
2.5	0.8	0.8	0.9	0.9	0.9	0.9	1.0	1.0	1.0
3.0	0.8	0.8	0.9	0.9	1.0	1.0	1.0	1.0	1.1
3.5	0.8	0.9	0.9	1.0	1.0	1.0	1.1	1.1	1.1
4.0	0.9	0.9	0.9	1.0	1.0	1.1	1.1	1.1	1.2
4.5	0.9	0.9	1.0	1.0	1.1	1.1	1.1	1.2	1.2
5.0	0.9	1.0	1.0	1.1	1.1	1.1	1.2	1.2	1.2
5.5	0.9	1.0	1.0	1.1	1.1	1.2	1.2	1.2	1.3
6.0	0.9	1.0	1.1	1.1	1.2	1.2	1.2	1.3	1.3
6.5	1.0	1.0	1.1	1.1	1.2	1.2	1.3	1.3	1.3
7.0	1.0	1.0	1.1	1.2	1.2	1.3	1.3	1.3	1.4
7.5	1.0	1.1	1.1	1.2	1.2	1.3	1.3	1.4	1.4

NOTES:

The above Tables give the required depth of embedment (L) for cylindrical concrete sign support foundations for a range of applied forces and sign heights. These depths have been derived using Broms theory. The following notes apply:

1. Refer to the notes on table usage at the front of this appendix
2. Foundations above the solid line are satisfactory for sign eccentricities up to 0.75m (i.e. signs up to 1.5m wide mounted on one edge). Foundations below the solid line do not allow for eccentrically mounted signs.
3. Tables assume that supports are embedded to within 100mm of the bottom of the foundation, or a steel/aluminium sleeve (with end cap) to take the support is cast to within 100mm of the bottom of the foundation.

Table C4
Table of Embedment Depths (L) for Cylindrical Sign Support Foundations.

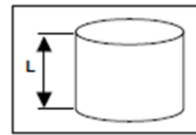

Su = 500 kPa									
300mm diameter Cylindrical Concrete Foundations									
F x A (KN)	Height to Centre of Sign (m)								
	1.0	1.5	2.0	2.5	3.0	3.5	4.0	4.5	5.0
0.25	0.5	0.6	0.6	0.6	0.6	0.6	0.6	0.6	0.6
0.5	0.6	0.6	0.6	0.6	0.6	0.6	0.6	0.6	0.6
1.0	0.6	0.6	0.6	0.6	0.6	0.6	0.7	0.7	0.7
1.5	0.6	0.6	0.6	0.7	0.7	0.7	0.7	0.7	0.7
2.0	0.6	0.6	0.7	0.7	0.7	0.7	0.7	0.7	0.7
2.5	0.6	0.7	0.7	0.7	0.7	0.7	0.7	0.8	0.8
3.0	0.7	0.7	0.7	0.7	0.7	0.7	0.8	0.8	0.8
3.5	0.7	0.7	0.7	0.7	0.8	0.8	0.8	0.8	0.8
4.0	0.7	0.7	0.7	0.7	0.8	0.8	0.8	0.8	0.8
4.5	0.7	0.7	0.7	0.8	0.8	0.8	0.8	0.8	0.9
5.0	0.7	0.7	0.8	0.8	0.8	0.8	0.8	0.9	0.9
5.5	0.7	0.7	0.8	0.8	0.8	0.8	0.9	0.9	0.9
6.0	0.7	0.8	0.8	0.8	0.8	0.9	0.9	0.9	0.9
6.5	0.7	0.8	0.8	0.8	0.8	0.9	0.9	0.9	0.9
7.0	0.7	0.8	0.8	0.8	0.9	0.9	0.9	0.9	0.9
7.5	0.7	0.8	0.8	0.8	0.9	0.9	0.9	0.9	1.0

400mm diameter Cylindrical Concrete Foundations									
F x A (KN)	Height to Centre of Sign (m)								
	1.0	1.5	2.0	2.5	3.0	3.5	4.0	4.5	5.0
0.25	0.5	0.5	0.5	0.6	0.6	0.6	0.6	0.6	0.6
0.5	0.6	0.6	0.6	0.6	0.6	0.6	0.6	0.6	0.6
1.0	0.6	0.6	0.6	0.6	0.6	0.6	0.6	0.6	0.6
1.5	0.6	0.6	0.6	0.6	0.6	0.7	0.7	0.7	0.7
2.0	0.6	0.6	0.6	0.7	0.7	0.7	0.7	0.7	0.7
2.5	0.6	0.6	0.7	0.7	0.7	0.7	0.7	0.7	0.7
3.0	0.6	0.7	0.7	0.7	0.7	0.7	0.7	0.7	0.8
3.5	0.6	0.7	0.7	0.7	0.7	0.7	0.7	0.8	0.8
4.0	0.7	0.7	0.7	0.7	0.7	0.7	0.8	0.8	0.8
4.5	0.7	0.7	0.7	0.7	0.7	0.8	0.8	0.8	0.8
5.0	0.7	0.7	0.7	0.7	0.8	0.8	0.8	0.8	0.8
5.5	0.7	0.7	0.7	0.8	0.8	0.8	0.8	0.8	0.8
6.0	0.7	0.7	0.7	0.8	0.8	0.8	0.8	0.8	0.9
6.5	0.7	0.7	0.8	0.8	0.8	0.8	0.8	0.9	0.9
7.0	0.7	0.7	0.8	0.8	0.8	0.8	0.8	0.9	0.9
7.5	0.7	0.7	0.8	0.8	0.8	0.8	0.9	0.9	0.9

NOTES:

The above Tables give the required depth of embedment (L) for cylindrical concrete sign support foundations for a range of applied forces and sign heights. These depths have been derived using Broms theory. The following notes apply:

1. Refer to the notes on table usage at the front of this appendix
2. Above foundations are satisfactory for sign eccentricities up to 0.75m (i.e. signs up to 1.5m wide mounted on edge)
3. Tables assume that supports are embedded to within 100mm of the bottom of the foundation, or a steel/aluminium sleeve (with end cap) to take the support is cast to within 100mm of the bottom of the foundation.

Table C5
Table of Embedment Depths (L) for Cylindrical Sign Support Foundations.

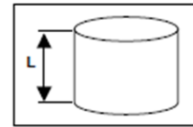

$\phi = 30$ Degrees									
300mm diameter Cylindrical Concrete Foundations									
F x A (KN)	Height to Centre of Sign (m)								
	1.0	1.5	2.0	2.5	3.0	3.5	4.0	4.5	5.0
0.25	0.5	0.5	0.6	0.6	0.6	0.6	0.7	0.7	0.7
0.5	0.6	0.7	0.7	0.7	0.8	0.8	0.8	0.9	0.9
1.0	0.8	0.8	0.9	0.9	1.0	1.0	1.1	1.1	1.1
1.5	0.9	1.0	1.0	1.1	1.1	1.2	1.2	1.3	1.3
2.0	1.0	1.1	1.1	1.2	1.3	1.3	1.3	1.4	1.4
2.5	1.1	1.2	1.2	1.3	1.4	1.4	1.5	1.5	1.5
3.0	1.1	1.2	1.3	1.4	1.4	1.5	1.6	1.6	1.6
3.5	1.2	1.3	1.4	1.5	1.5	1.6	1.6	1.7	1.7
4.0	1.3	1.4	1.5	1.5	1.6	1.7	1.7	1.8	1.8
4.5	1.3	1.4	1.5	1.6	1.7	1.7	1.8	1.9	1.9
5.0	1.4	1.5	1.6	1.7	1.7	1.8	1.9	1.9	2.0
5.5	1.4	1.6	1.6	1.7	1.8	1.9	1.9	2.0	2.0
6.0	1.5	1.6	1.7	1.8	1.9	1.9	2.0	2.1	2.1
6.5	1.5	1.7	1.8	1.8	1.9	2.0	2.1	2.1	2.2
7.0	1.6	1.7	1.8	1.9	2.0	2.0	2.1	2.2	2.2
7.5	1.6	1.8	1.9	1.9	2.0	2.1	2.2	2.2	2.3

400mm diameter Cylindrical Concrete Foundations									
F x A (KN)	Height to Centre of Sign (m)								
	1.0	1.5	2.0	2.5	3.0	3.5	4.0	4.5	5.0
0.25	0.5	0.5	0.5	0.5	0.6	0.6	0.6	0.6	0.7
0.5	0.5	0.6	0.6	0.7	0.7	0.7	0.8	0.8	0.8
1.0	0.7	0.7	0.8	0.8	0.9	0.9	1.0	1.0	1.0
1.5	0.8	0.9	0.9	1.0	1.0	1.1	1.1	1.1	1.2
2.0	0.9	1.0	1.0	1.1	1.1	1.2	1.2	1.3	1.3
2.5	1.0	1.0	1.1	1.2	1.2	1.3	1.3	1.4	1.4
3.0	1.0	1.1	1.2	1.2	1.3	1.4	1.4	1.4	1.5
3.5	1.1	1.2	1.3	1.3	1.4	1.4	1.5	1.5	1.6
4.0	1.1	1.2	1.3	1.4	1.4	1.5	1.6	1.6	1.6
4.5	1.2	1.3	1.4	1.4	1.5	1.6	1.6	1.7	1.7
5.0	1.2	1.3	1.4	1.5	1.6	1.6	1.7	1.7	1.8
5.5	1.3	1.4	1.5	1.6	1.6	1.7	1.7	1.8	1.8
6.0	1.3	1.4	1.5	1.6	1.7	1.7	1.8	1.9	1.9
6.5	1.4	1.5	1.6	1.7	1.7	1.8	1.8	1.9	2.0
7.0	1.4	1.5	1.6	1.7	1.8	1.8	1.9	2.0	2.0
7.5	1.5	1.6	1.7	1.7	1.8	1.9	1.9	2.0	2.1

NOTES:

The above Tables give the required depth of embedment (L) for cylindrical concrete sign support foundations for a range of applied forces and sign heights. These depths have been derived using Broms theory. The following notes apply:

1. Refer to the notes on table usage at the front of this appendix
2. Above foundations do not allow for eccentrically mounted signs
3. Tables assume that supports are embedded to within 100mm of the bottom of the foundation, or a steel/aluminium sleeve (with end cap) to take the support is cast to within 100mm of the bottom of the foundation.

Table C6
Table of Embedment Depths (L) for Cylindrical Sign Support Foundations.

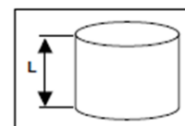

$\phi = 35$ Degrees									
300mm diameter Cylindrical Concrete Foundations									
F x A (KN)	Height to Centre of Sign (m)								
	1.0	1.5	2.0	2.5	3.0	3.5	4.0	4.5	5.0
0.25	0.5	0.5	0.5	0.6	0.6	0.6	0.6	0.6	0.7
0.5	0.6	0.6	0.7	0.7	0.7	0.8	0.8	0.8	0.8
1.0	0.7	0.8	0.8	0.9	0.9	1.0	1.0	1.0	1.1
1.5	0.8	0.9	0.9	1.0	1.1	1.1	1.1	1.2	1.2
2.0	0.9	1.0	1.1	1.1	1.2	1.2	1.3	1.3	1.3
2.5	1.0	1.1	1.1	1.2	1.3	1.3	1.4	1.4	1.4
3.0	1.1	1.1	1.2	1.3	1.3	1.4	1.4	1.5	1.5
3.5	1.1	1.2	1.3	1.4	1.4	1.5	1.5	1.6	1.6
4.0	1.2	1.3	1.4	1.4	1.5	1.5	1.6	1.6	1.7
4.5	1.2	1.3	1.4	1.5	1.6	1.6	1.7	1.7	1.8
5.0	1.3	1.4	1.5	1.5	1.6	1.7	1.7	1.8	1.8
5.5	1.3	1.4	1.5	1.6	1.7	1.7	1.8	1.8	1.9
6.0	1.4	1.5	1.6	1.7	1.7	1.8	1.8	1.9	2.0
6.5	1.4	1.5	1.6	1.7	1.8	1.8	1.9	2.0	2.0
7.0	1.5	1.6	1.7	1.8	1.8	1.9	2.0	2.0	2.1
7.5	1.5	1.6	1.7	1.8	1.9	1.9	2.0	2.1	2.1

400mm diameter Cylindrical Concrete Foundations									
F x A (KN)	Height to Centre of Sign (m)								
	1.0	1.5	2.0	2.5	3.0	3.5	4.0	4.5	5.0
0.25	0.5	0.5	0.5	0.5	0.5	0.6	0.6	0.6	0.6
0.5	0.5	0.6	0.6	0.6	0.7	0.7	0.7	0.7	0.8
1.0	0.6	0.7	0.7	0.8	0.8	0.9	0.9	0.9	1.0
1.5	0.7	0.8	0.9	0.9	1.0	1.0	1.0	1.1	1.1
2.0	0.8	0.9	0.9	1.0	1.1	1.1	1.1	1.2	1.2
2.5	0.9	1.0	1.0	1.1	1.1	1.2	1.2	1.3	1.3
3.0	0.9	1.0	1.1	1.2	1.2	1.3	1.3	1.3	1.4
3.5	1.0	1.1	1.2	1.2	1.3	1.3	1.4	1.4	1.5
4.0	1.1	1.1	1.2	1.3	1.3	1.4	1.4	1.5	1.5
4.5	1.1	1.2	1.3	1.3	1.4	1.5	1.5	1.6	1.6
5.0	1.1	1.2	1.3	1.4	1.5	1.5	1.6	1.6	1.7
5.5	1.2	1.3	1.4	1.4	1.5	1.6	1.6	1.7	1.7
6.0	1.2	1.3	1.4	1.5	1.6	1.6	1.7	1.7	1.8
6.5	1.3	1.4	1.5	1.5	1.6	1.7	1.7	1.8	1.8
7.0	1.3	1.4	1.5	1.6	1.6	1.7	1.8	1.8	1.9
7.5	1.3	1.4	1.5	1.6	1.7	1.7	1.8	1.9	1.9

NOTES:

The above Tables give the required depth of embedment (L) for cylindrical concrete sign support foundations for a range of applied forces and sign heights. These depths have been derived using Broms theory. The following notes apply:

1. Refer to the notes on table usage at the front of this appendix
2. Above foundations do not allow for eccentrically mounted signs
3. Tables assume that supports are embedded to within 100mm of the bottom of the foundation, or a steel/aluminium sleeve (with end cap) to take the support is cast to within 100mm of the bottom of the foundation.

Table C7
Table of Embedment Depths (L) for Cylindrical
Sign Support Foundations

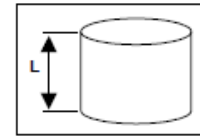

$\phi = 45$ Degrees									
300mm diameter Cylindrical Concrete Foundations									
F x A (KN)	Height to Centre of Sign (m)								
	1.0	1.5	2.0	2.5	3.0	3.5	4.0	4.5	5.0
0.25	0.5	0.5	0.5	0.5	0.5	0.35	0.5	0.6	0.6
0.5	0.5	0.5	0.6	0.6	0.6	0.7	0.7	0.7	0.7
1.0	0.6	0.7	0.7	0.7	0.8	0.8	0.8	0.9	0.9
1.5	0.7	0.8	0.8	0.9	0.9	0.9	1.0	1.0	1.0
2.0	0.8	0.8	0.9	0.9	1.0	1.0	1.1	1.1	1.1
2.5	0.8	0.9	1.0	1.0	1.1	1.1	1.2	1.2	1.2
3.0	0.9	1.0	1.0	1.1	1.1	1.2	1.2	1.3	1.3
3.5	0.9	1.0	1.1	1.2	1.2	1.3	1.3	1.3	1.4
4.0	1.0	1.1	1.1	1.2	1.3	1.3	1.4	1.4	1.4
4.5	1.0	1.1	1.2	1.3	1.3	1.4	1.4	1.5	1.5
5.0	1.1	1.2	1.2	1.3	1.4	1.4	1.5	1.5	1.6
5.5	1.1	1.2	1.3	1.4	1.4	1.5	1.5	1.6	1.6
6.0	1.2	1.2	1.3	1.4	1.5	1.5	1.6	1.6	1.7
6.5	1.2	1.3	1.4	1.4	1.5	1.6	1.6	1.7	1.7
7.0	1.2	1.3	1.4	1.5	1.5	1.6	1.7	1.7	1.8
7.5	1.3	1.4	1.4	1.5	1.6	1.6	1.7	1.8	1.8

400mm diameter Cylindrical Concrete Foundations									
F x A (KN)	Height to Centre of Sign (m)								
	1.0	1.5	2.0	2.5	3.0	3.5	4.0	4.5	5.0
0.25	0.5	0.5	0.5	0.5	0.5	0.5	0.5	0.5	0.5
0.5	0.5	0.5	0.5	0.5	0.6	0.6	0.6	0.6	0.7
1.0	0.5	0.6	0.6	0.7	0.7	0.7	0.8	0.8	0.8
1.5	0.6	0.7	0.7	0.8	0.8	0.9	0.9	0.9	0.9
2.0	0.7	0.8	0.8	0.9	0.9	0.9	1.0	1.0	1.0
2.5	0.7	0.8	0.9	0.9	1.0	1.0	1.0	1.1	1.1
3.0	0.8	0.9	0.9	1.0	1.0	1.1	1.1	1.2	1.2
3.5	0.8	0.9	1.0	1.0	1.1	1.1	1.2	1.2	1.2
4.0	0.9	1.0	1.0	1.1	1.1	1.2	1.2	1.3	1.3
4.5	0.9	1.0	1.1	1.1	1.2	1.2	1.3	1.3	1.4
5.0	1.0	1.0	1.1	1.2	1.2	1.3	1.3	1.4	1.4
5.5	1.0	1.1	1.2	1.2	1.3	1.3	1.4	1.4	1.5
6.0	1.0	1.1	1.2	1.3	1.3	1.4	1.4	1.5	1.5
6.5	1.1	1.2	1.2	1.3	1.4	1.4	1.5	1.5	1.5
7.0	1.1	1.2	1.3	1.3	1.4	1.4	1.5	1.5	1.6
7.5	1.1	1.2	1.3	1.4	1.4	1.5	1.5	1.6	1.6

NOTES:

The above Tables give the required depth of embedment (L) for cylindrical concrete sign support foundations for a range of applied forces and sign heights. These depths have been derived using Broms theory. The following notes apply:

1. Refer to the notes on table usage at the front of this appendix
2. Above foundations are satisfactory for sign eccentricities up to 0.75m (i.e. signs up to 1.5m wide mounted on edge)
3. Tables assume that supports are embedded to within 100mm of the bottom of the foundation, or a steel/aluminium sleeve (with end cap) to take the support is cast to within 100mm of the bottom of the foundation.

Table C8
Table of Lengths (L) for
Pad Sign Support Foundations.

For soil conditions not worse than:
Loose-Med dense Cohesion less soil (Gravels and sands)
 Not less than ϕ 30 degrees
Firm cohesive soils (Silts and clays)
 Not less than S_u not less than 50 kPa

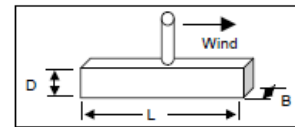

500mm wide (b) x 400mm deep (D) Concrete Pad Foundations									
F x A (KN)	Height to Centre of Sign (m)								
	1.0	1.5	2.0	2.5	3.0	3.5	4.0	4.5	5.0
0.25	0.5	0.5	0.6	0.6	0.7	0.7	0.8	0.8	0.8
0.5	0.6	0.7	0.8	0.9	0.9	1.0	1.1	1.1	1.2
1.0	0.9	1.0	1.1	1.2	1.3	1.4	1.5	1.5	1.6
1.5	1.0	1.2	1.3	1.4	1.6	1.7	1.8	1.9	1.9
2.0	1.2	1.4	1.5	1.7	1.8	1.9	2.0	2.1	2.2
2.5	1.3	1.5	1.7	1.8	2.0	2.1	2.2	2.4	2.5
3.0	1.4	1.6	1.8	2.0	2.2	2.3	2.4	2.7	2.8
3.5	1.5	1.8	2.0	2.2	2.3	2.5	2.7	2.9	3.0
4.0	1.6	1.9	2.1	2.3	2.5	2.7	2.9	-	-
4.5	1.7	2.0	2.2	2.4	2.7	2.9	-	-	-
5.0	1.8	2.1	2.3	2.7	2.9	3.0	-	-	-
5.5	1.9	2.2	2.4	2.8	3.0	-	-	-	-
6.0	2.0	2.3	2.6	2.9	-	-	-	-	-
6.5	2.0	2.4	2.7	3.0	-	-	-	-	-
7.0	2.1	2.4	2.8	-	-	-	-	-	-
7.5	2.2	2.6	2.9	-	-	-	-	-	-

NOTES:

The above Tables give the required length (L) for concrete pad sign support foundations for a range of applied forces and sign heights. The values given are for a 500mm wide pad of depth 400mm, for use in areas with shallow services. These depths have been derived using Meyerhof Bearing Capacity Analysis and Factors. The following notes apply:

1. Refer to the notes on table usage at the front of this appendix
2. Soil descriptions are based on NZ Geomechanics Society Guidelines for Field Descriptions of soils and rocks in Engineering use
3. The values in the above Table assumes that finished ground level is a minimum of 150mm above the top of the Pad Foundation
4. Above foundations do not allow for eccentrically mounted signs and are based on a conservative assumption of zero sign weight.
5. Pad reinforcement is detailed below for a concrete compressive strength of 17.5 MPa. Cover is 75mm with the support embedded to within 75mm of the underside of the Pad.

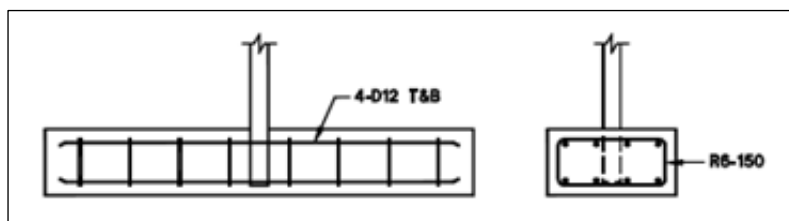

APPENDIX D

WORKED EXAMPLE USING SIGN SUPPORT & FOUNDATION SELECTION CHARTS

D1 Worked Example Using Support Selection Charts in Appendix B
Sign Size and Locations

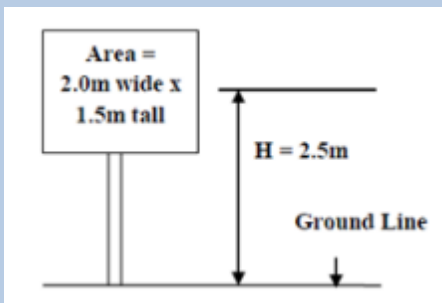

The sign shown is to be located at the side of the road (not over the road) in a low density suburban area in the central North Island. The topography is flat. This worked example illustrates how the design aid charts in Appendix B and C can be used to select an appropriate support and foundation size for the sign installation.

Clause Reference	Worked Example
5.2	<p>Importance Level for Design Sign panel area is less than or equal to 4.7m² and not over the carriageway. Importance level = 1 and annual probability of exceedance for wind ultimate limit state is 1/50.</p>
5.2	<p>Terrain Factors If specific design is being carried out to AS/NZS 1170.2 the terrain factors adopted are contained in that code.</p> <p>If the terrain and sign location are within the bounds covered by the charts in Appendix B (see guidance notes in Appendix B) the charts can be used rather than carrying out specific design to AS/NZS 1170. (Note: A more refined solution may be achieved through specific design to AS/NZS 1170).</p>
Appendix B	<p>The charts in Appendix B can be used for this example because the sign is in gentle topography, the sign is below an elevation of 500m above sea level, the importance level is 1, and the sign panel area is less than or equal to 4.7m² and is not over the carriageway.</p> <p>The above sign is in Terrain Category 3 (as defined in Clause 4.2.1 of AS/NZS 1170.2 with a broader description given in figures C4.2.1 (A) – C4.2.1 (F) in the commentary to AS/NZS1170.2).</p>
B1 (a)	<p>Since the sign is to be located in an area with gentle/flat topography there is no need to modify the sign area to account for the effect of any hills. If the sign were to be located adjacent to hills or escarpments (with slopes up to 1 vertical to 5 horizontal) then the sign area would need to be multiplied by 1.5 before continuing.</p>
B1 (b)	<p>Sign is in Terrain Category 3. Therefore we can multiply the sign area by 0.8 before entering the charts (charts are based on Terrain Category 2). The 0.8 area reduction factor will account for the sign being in Terrain Category 3.</p>

B1.1 (a)	Wind speed = 39m/s for the central North Island. Therefore for a steel CHS pole we would use Chart B3.
B1.1 (e)	<p>Because the sign is more than 1.3m wide more than one support will be required. The sign area must be multiplied by (1.15/n) before entering the chart to determine the support size required. This will give the effective area per support. Check with say two supports.</p> <p>Effective Area = $(1.15/2) \times 0.8 \times 1.5\text{m tall} \times 2.0\text{m wide} = 1.38\text{m}^2$ per support. (Where 0.8 = area reduction factor to account for the sign being in Terrain Category 3, determined from change of Mz cat in AS/NZS 1170.2, Table 4.1(A), $(0.83/091)^2 \approx 0.8$)</p>
B1.2 and Chart B3	<p>Using Chart B3 with a height to the centre of sign of 2.5m, we require two 76 diameter CHS x 3.2mm thick sections for the given sign.</p> <p>Two Steel CHS 76 x 3.2mm thick poles are required to support the sign panel</p>

D2. Worked example using foundation selection charts in Appendix C Foundation Conditions

The foundation selection charts in Appendix C can be used for signs with a panel area less than or equal to 4.7m² and not over the road as specified in Clause 5.2.

The sign in this example is to be located in medium dense sandy soil overlain by 100mm of topsoil/soft sediment.

Clause Reference	Worked Example
Appendix C C1.2	Tables A, B and C in the guidance to Appendix C indicate that Table C5 should be used for the above soil conditions. Table C8 can be used if a shallow pad foundation is required to avoid any services.
Appendix C C1.1 (c)	The sign area (A) used should be that used for the support selection table. ie in this case $A = 1.38\text{m}^2$ per support (see example above). The value of the wind pressure F is also given on the appropriate support selection chart. $F \times A = 1.13\text{kPa}$ (from Chart 3) $\times 1.38\text{m}^2 = 1.56\text{kN}$.
Appendix C Table C5	For a 300mm diameter concrete foundation the depth L must be greater or equal to 1.1m (using height to centre of sign = 2.5m and $F \times A = 1.5\text{kN}$ in the table).
Appendix C C1.1 (d)-(f)	<p>Therefore the depth of foundation required = 1.1m + 0.1m of soft topsoil/sediment. ie the topsoil is not included in the calculation of embedment depth; therefore we need to add 0.1m.</p> <p>A 300 diameter by 1.2m deep concrete foundation is required for each support.</p>

APPENDIX E

ALTERNATIVE SUBSTRATE AND COMPONENTRY FOR TRAFFIC SIGN SYSTEMS

The Transport Agency recognises that alternative sign substrates, stiffening and jointing systems, fixtures, fixings and componentry may be introduced for potential use in New Zealand. Before being accepted for such use the items must meet the requirements of NZTA P24 to the satisfaction of the Transport Agency.

These requirements include laboratory-based testing for strength & rigidity, impact resistance, resistance to heat and cold, bending and twisting, adhesive bond strength for the application of retroreflective sheeting and resistance of the assembled sign system to specified New Zealand windage conditions.

Impact testing, resistance to heat and cold (-20°C to +60°C), bending and twisting tests must confirm that a substrate material exhibits no evidence of delamination, deformation, cracking or crazing, softening, chalking, lessening of rigidity, flatness or other characteristic that could endanger the panel for use as a traffic sign

Testing must include substrate stiffeners, substrate joiners and the integrity and strength of their attachment to a substrate when exposed to expected New Zealand wind conditions. All sign and attachment components within the system, including paint finish (rear of substrate), brackets and fixings that will affix the sign to its support system must meet the overall *Matched Component System* requirement.

The output from such testing must then include the publication of comprehensive stiffener selection and spacing charts for distribution to sign manufacturers, a copy of which must be lodged at the Transport Agency.

Following the laboratory and windage testing, outdoor accelerated weathering tests at the Allunga Exposure Laboratory for a period of two years (15,000 MJ/m²) may be required to confirm durability of the substrate material in a manner similar to that used for retroreflective sheeting and to confirm sheeting adhesion to the substrate.

Testing of the material must show no sign of deterioration such as but not limited to cracking, scaling and pitting, blistering, delamination, distortion, staining or chalking.

Interim Acceptance

After successful initial laboratory and windage testing the Transport Agency may award *Interim Acceptance* for the *Matched Component System* or individual system components based on what has been tested.

Interim Acceptance of the complete *Matched Component System* will permit the alternative substrate material and sign system to be used for small signs limited for use as ground mounted signs up to a maximum of 4.7m²

Accepted Material

Accepted Material status for the *Matched Component System* will be awarded following the successful completion of durability testing that the Transport Agency may require to be completed at the Allunga Exposure Laboratory in North Queensland. *Accepted Material status for the Matched Component System* will permit use for all sign sizes and placements.

Ultimate acceptance, restricted to the complete sign system tested as a *Matched Component System*, may be granted upon the listing of all appropriate components in Appendix F.

E.1 Composite Substrate sign systems:

Composite based sign substrate materials will typically consist of a durable core material, such as but not limited to polyethylene, that is sandwiched between two cover sheets (Figure E.1) that will typically, but not necessarily, be aluminium sheet of between 0.3 and 0.4mm thickness, making an overall substrate thickness of approximately 3.0mm.

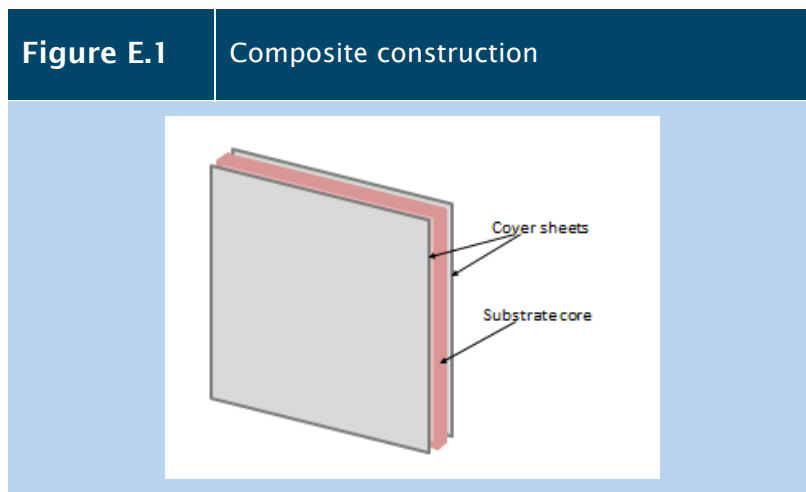

Laboratory testing must be undertaken to confirm that cover sheets are constructed from sheeting that is specifically designed for use with retroreflective traffic signs when prepared in compliance with the retroreflective sheeting manufacturer's specification that will support any warranty available.

E.2 UV Stabilised plastic substrate sign systems

Any plastic substrate material used as a sign substrate must be UV Stabilised and may only be used in special circumstances after being specifically accepted for such use by the Transport Agency with the support of the retroreflective sheeting manufacturer to assure that sign warranties will be maintained.

Such material as a minimum must meet the test requirements specified in the British Standard BS 8442 *Miscellaneous road traffic signs and devices*.

E.3 Channel, extrusions, brackets, fittings and fixtures

Channel stiffening extrusions used to form a *Matched Component System* with an alternative substrate material may use a currently accepted extruded alloy 6261-T5 or equivalent as referred to in AS/NZS 1866 *Aluminium and aluminium alloys*.

The substrate material and each individual component in the assembled *Matched Component System* must be supported by successful test results to recognised appropriate Standards in order to meet the requirements of NZTA P24 and be accepted by the Transport Agency. Such testing must be conducted at an independent (NATA/IANZ) test facility or such other laboratory approved by the Transport Agency.

Where components in the sign system are currently accepted by the Transport Agency (Refer Appendix F) such components need not be retested but their inclusion as a complete match component sign system must be tested and accepted as a fully assembled sign system. Any individual component introduced without prior Transport Agency acceptance must be individually tested and tested as the assembled sign system.

The output from such testing must include the publication of comprehensive stiffener selection and spacing charts for use by sign manufacturers.

APPENDIX F

NZ TRANSPORT AGENCY ACCEPTED PRODUCTS AND SYSTEMS.

The following products and systems have been either formally accepted or have been tested to meet the relevant section of NZTA P24 and accepted for use in conjunction with NZTA P24 and use on the New Zealand roading network.

No.	Submitting Company	Product Description	Accepted Product & Code	Date NZTA Acceptance mm/yyyy
1	Roadsign Supports Ltd	Breakaway Sign Supports	NECKLEN 80, 100 and 170 series galvanized rectangular hollow section carbon steel poles.	06/2012
2	Signfix Systems Ltd	Breakaway and Yielding Sign Supports	SIGNFIX Aluminium Fluted Poles 60, 76, 89, 102 and 114mm Outer diameter	01/1995
3	Signfix Systems Ltd	Foundation components – Ground Sockets	SIGNFIX Standard (White) and Safety (Ghost grey) Aluminium Ground Sockets to suit 60, 76, 89, 102 and 114mm SIGNFIX Aluminium fluted poles and P24 compliant 60 and 76mm steel poles	01/1995

4	Signfix Systems Ltd	Sign Installation Components – Brackets, Clips and Stainless Steel Banding	SIGNFIX: ARC Brackets, LRH Brackets, BBC Clips, AUO Brackets, Back to Back AUO Brackets, Street Name Blade Brackets Stainless Steel Strapping and Buckles Universal Channel Clamp Lip Lok Bolts	01/1995
5	Signfix Systems Ltd	Aluminium Extrusion Sign Stiffening (Support Channel)	SIGNFIX Small, Medium, Interlink, Interlink Mate, Dovetail and Dovetail Mate Sign Support Channels	01/1995
6	Signfix Systems Ltd	Aluminium Extrusion Street Name Blade Extrusion	SIGNFIX 150mm, 200mm, 225mm and 250mm deep Street Name Blade SIGNFIX 150mm deep No Exit “Slide-on” Street Name Blade	01/1995
7	Traffic Signs NZ Ltd	Breakaway and Yielding Sign Supports	TSNZ Aluminium Fluted Poles 60, 76, 89, 102 and 114mm Outer diameter	08/2019
8	Traffic Signs NZ Ltd	Foundation Components – Ground Sockets	TSNZ Standard (White) and Safety (Mill Finish) Aluminium Ground Sockets to suit 60, 76, 89, 102 and 114mm TSNZ Aluminium fluted poles and P24 compliant 60 and 76mm steel poles	08/2019

9	Traffic Signs NZ Ltd	Sign Installation Components – Brackets, Clips and Stainless Steel Banding	<p>TSNZ ARB Brackets, RHS Brackets, AUO Brackets, Back to Back, AUO Brackets, Street Name Blade Brackets, Mid Mount Brackets Stainless Steel Strapping and Buckles Universal clamp and joiner clips Lip Lok Bolts</p>	08/2019
10	Traffic Signs NZ Ltd	Aluminium Extrusion Sign Stiffening (Support Channel)	TSNZ Small, Medium, Medium Joiner, Medium Joiner Channel, Large Joiner and Large Channel Joiner Sign Support Channels	08/2019
11	Traffic Signs NZ Ltd	Aluminium Extrusion Street Name Blade Extrusion	<p>TSNZ 150mm, 200mm, 225mm and 250mm deep Street Name Blade</p> <p>TSNZ 150mm deep No Exit “Slide-on” Street Name Blade</p>	08/2019

