

WELLINGTON, NEW ZEALAND

PURSUANT to *section 152* of the Land Transport Act 1998

I, *Harry James Duynhoven*, Minister for Transport Safety,

HEREBY make the following ordinary Rule:

Land Transport Rule: Heavy Vehicles 2004

SIGNED AT Wellington

This 25th day of August 2004

Harry James Duynhoven

Minister for Transport Safety

Land Transport Rule

Heavy Vehicles 2004

Rule 31002

As at 1 May 2021

Land Transport Rule

Heavy Vehicles 2004

As at 1 May 2021

Contents

| | |
|---|-----------|
| Compilation notes | i |
| Part 1 Rule requirements | 1 |
| Section 1 Application | 1 |
| 1.1 Title | 1 |
| 1.2 Scope of the rule | 1 |
| 1.3 Date when rule comes into force | 1 |
| 1.4 Application of rule provisions | 1 |
| Section 2 Vehicle standards | 2 |
| 2.1 Vehicle standards include amendments to standards | 2 |
| 2.2 Vehicle standards include alternatives | 2 |
| Section 3 General safety requirements | 2 |
| 3.1 Chassis and body strength | 2 |
| 3.2 Vehicle body and equipment attachment | 3 |
| 3.3 Cab-guards | 3 |
| 3.4 Transmission | 4 |
| 3.5 Axles | 4 |
| 3.6 Suspension | 5 |
| 3.7 Ballrace turntables | 5 |
| 3.8 Electrical requirements | 5 |
| 3.9 Equipment locking devices | 6 |
| Section 4 Towing connection requirements | 7 |
| 4.1 Vehicle and component requirements | 7 |
| 4.2 Tractors and agricultural trailers | 7 |
| 4.3 Vehicle recovery service vehicles | 8 |
| 4.4 Drawbeams and towbars | 9 |
| 4.5 Drawbars | 10 |
| 4.6 Couplings | 10 |
| 4.7 Fifth wheel assemblies | 11 |
| 4.8 Skid plates and kingpins | 13 |
| Section 5 Load securing equipment requirements | 17 |
| 5.1 Load securing equipment | 17 |
| 5.2 Containment by a vehicle body | 17 |
| 5.3 Stockcrates and stockcrate retention devices | 17 |
| 5.4 Curtain-sided bodies | 18 |
| 5.5 Load anchorage points | 18 |
| 5.6 Headboards, sideboards and tailboards | 19 |

| | | |
|--|---|-----------|
| Section 6 | Modification | 20 |
| 6.1 | General requirements for modification | 20 |
| 6.2 | Modification affecting engine and transmission | 21 |
| 6.3 | Modification affecting axles, suspension and steering | 21 |
| 6.4 | Modification affecting chassis | 21 |
| 6.5 | Conversion of a vehicle to right-hand drive | 22 |
| 6.6 | Conversion of a vehicle to dual steering | 23 |
| Section 7 | Repair | 25 |
| Section 8 | Responsibilities | 25 |
| 8.1 | Responsibilities of operators | 25 |
| 8.2 | Responsibilities of repairers | 25 |
| 8.3 | Responsibilities of modifiers | 25 |
| 8.4 | Responsibilities of vehicle inspectors and inspecting organisations | 26 |
| 8.5 | Responsibilities of manufacturers and retailers | 26 |
| 8.6 | Functions and powers of the Director | 27 |
| Section 9 | Transitional provisions and savings | 28 |
| Part 2 Definitions | | 30 |
| Table A—Vehicle classes | | 39 |
| Part 3 Schedules | | 43 |
| Schedule 1 Bolster Attachment Code | | 43 |
| Schedule 2 Bolster Attachment Code | | 53 |
| | Table A: Vehicle Bolster attachment systems | 79 |
| | Table B: Pre-Certified Components or subassemblies | 80 |
| | Table C: Bolster attachment components with a shorter life than bolster attachment as a whole | 82 |
| Schedule 3 NZ Truck-Trailer Manufacturers' Federation Recommended Practice | | 83 |
| Schedule 4 Bolster Attachment Code | | 97 |
| Section 1 | INTRODUCTION | 97 |
| 1.1 | Objective | 97 |
| 1.2 | Certification life | 97 |
| 1.3 | Proprietary components | 98 |
| 1.4 | Repairs and modifications | 98 |
| 1.5 | Vehicle and bolster identification | 98 |
| Section 2 | DEFINITIONS | 98 |
| 2.1 | Vehicle payload | 98 |
| 2.2 | Rated Bolster Load; L_R | 98 |
| 2.3 | Bolster Assembly Mass; D | 99 |
| 2.4 | Design Bolster Load: Static: L_{DS} Dynamic: L_{DF} | 99 |

| | | |
|---|--|------------|
| 2.5 | Loads | 99 |
| 2.6 | General design requirements | 100 |
| 2.7 | Load centre | 100 |
| 2.8 | Certifying Engineer | 101 |
| 2.9 | Longs Bolster | 101 |
| 2.10 | Shorts Bolster | 101 |
| 2.11 | Convertible (longs/shorts) vehicle | 101 |
| Section 3 | VERTICAL LOADS | 101 |
| 3.1 | Application | 101 |
| 3.2 | Static Vertical Load; P_V | 102 |
| 3.3 | Dynamic Vertical Load Range; Q_V | 102 |
| Section 4 | TRANSVERSE LOADS | 102 |
| 4.1 | Application | 102 |
| 4.2 | Static Transverse Load; P_T (<i>applies at the Load Centre</i>) | 103 |
| 4.3 | Dynamic Transverse Load; Q_T (<i>applies at the Load Centre</i>) | 103 |
| Section 5 | LONGITUDINAL LOADS | 103 |
| 5.1 | Application | 103 |
| 5.2 | Static Longitudinal Loads P_{LF} , P_{LR} | 103 |
| 5.3 | Dynamic Longitudinal Loads; Q_{L1} ; Q_{L2} | 104 |
| Section 6 | SPECIAL TYPES OF BOLSTER MOUNTINGS | 104 |
| 6.1 | Torsionally Independent Bolsters | 105 |
| 6.2 | Sliding Bolsters | 105 |
| 6.3 | Resiliently Mounted Bolsters | 106 |
| 6.4 | Longs and Convertible Units | 106 |
| Section 7 | DESIGN OF BOLTED CONNECTIONS | 108 |
| Section 8 | WELDING CONSIDERATIONS | 109 |
| Section 9 | SECONDARY ATTACHMENT DEVICES | 109 |
| <u>Appendix Sample forms of NZTA approved acceptable design certificates</u> | | 110 |

Compilation notes

1 General

This is a compilation of *Land Transport Rule: Heavy Vehicles 2004* that incorporates all the amendments to that Rule as at the date of the last amendment to it.

2 Format changes

Format changes to compilations are made so that the format of the compilation is consistent with current drafting practice, including:

- changes to the setting out of provisions, tables, and schedules:
- the repositioning of headings or notes:
- changes to typeface and type size:
- the addition or removal of boldface, italics, and similar textual attributes:
- the addition or removal of quote marks and rules:
- changes to the case of letters or words:
- addition of history and editorial notes.

3 Amendments incorporated in this reprint

Land Transport Rule: Heavy Vehicles Amendment 2021

Land Transport Rule: Agency to Director (Consequential Changes) Amendment 2021

Land Transport Rule: Heavy Vehicles Amendment 2019

Land Transport Amendment Act 2017

Land Transport Rule: Heavy Vehicles Amendment 2016

Land Transport Rule: Heavy Vehicles Amendment 2014

Land Transport Rule: Heavy Vehicles Amendment 2013

Land Transport Rule: Heavy Vehicles Amendment (No 2) 2011

Land Transport Rule: Heavy Vehicles Amendment 2011

Land Transport Rule: Vehicle Standards Compliance Amendment 2011

Land Transport Rule: Vehicle Standards Compliance Amendment 2010

Land Transport Management Amendment Act 2008

Land Transport Rule: Heavy Vehicles Amendment 2008

Land Transport Rule: Heavy Vehicles Amendment 2007

Land Transport Rule: Heavy Vehicles Amendment 2005

Part 1

Rule requirements

Section 1 Application

1.1 Title

This rule is *Land Transport Rule: Heavy Vehicles 2004*.

1.2 Scope of the rule

1.2(1) This rule applies to heavy motor vehicles.

1.2(2) This rule does not apply to an armoured vehicle used exclusively as equipment of the New Zealand Defence Force.

1.2(3) This rule specifies requirements:

(a) with which a vehicle must comply so as to be operated on a road; and

(b) that are, for the purposes of *Land Transport Rule: Vehicle Standards Compliance 2002*, the applicable requirements for the inspection and certification of heavy vehicles and specific aspects of those vehicles.

1.2(4) The applicable requirements in this rule for the purposes of specialist inspection and certification of heavy vehicles and specific aspects of those vehicles under *Land Transport Rule: Vehicle Standards Compliance 2002* are in 3.2(3), 4.4, 4.5, 4.6(3), 4.7(1)(c), 4.7(2), 4.7(2A), 4.7(2B), 4.7(3), 4.7(3A), 4.7(5), 4.8(1)(a)(iii), 4.8(2), 4.8(2A), 4.8(3), 4.8(4), 5.3(3), 5.5, 6.2 to 6.6 and 7.1(2).

Clause 1.2(4): amended, on 28 April 2008, by *clause 2.1* of *Land Transport Rule: Heavy Vehicles Amendment 2008*.

Clause 1.2(4): amended, on 1 November 2014, by *clause 2.1* of *Land Transport Rule: Heavy Vehicles Amendment 2014*.

Clause 1.2(4): amended, on 1 November 2015, by *clause 2.1(1)* and *2.1(2)* of *Land Transport Rule: Heavy Vehicles Amendment 2015*.

1.3 Date when rule comes into force

This rule comes into force on 1 April 2005.

1.4 Application of rule provisions

1.4(1) If there is a conflict between a provision of this rule and the corresponding provision of a document incorporated by reference in the rule, the provision of the rule applies.

- 1.4(2) If there is a conflict between a provision of this rule and a provision of *Land Transport Rule: Vehicle Standards Compliance 2002*, the provision of *Land Transport Rule: Vehicle Standards Compliance 2002* applies.

Section 2 Vehicle standards

2.1 Vehicle standards include amendments to standards

An approved vehicle standard in this rule includes all amendments to that standard, some of which may apply to classes of vehicle additional to those covered by the original standard.

2.2 Vehicle standards include alternatives

For the purposes of this Rule, “*Australian/New Zealand Standard: 1554, Structural steel welding*” is an alternative to “*New Zealand Standard: 4711, Qualification tests for metal-arc welders*” wherever it is referenced in an approved standard.

Clause 2.2: inserted, on 28 April 2008, by clause 2.2 of Land Transport Rule: Heavy Vehicles Amendment 2008.

Section 3 General safety requirements

3.1 Chassis and body strength

- 3.1(1) The chassis and body of a vehicle must be of adequate strength for all conditions of loading and operation for which the vehicle was constructed.
- 3.1(2) The body of a vehicle of monocoque construction must be of adequate strength for all conditions of loading and operation for which the vehicle was constructed.
- 3.1(3) A load-bearing structure, other than a chassis, a body fitted to the chassis or a monocoque body, must be of adequate strength for all conditions of loading and operation for which the vehicle was constructed.
- 3.1(4) A vehicle must have a chassis rating if the vehicle is required to have a certificate of loading under *Land Transport Rule: Vehicle Standards Compliance 2002*.

3.2 Vehicle body and equipment attachment

- 3.2(1) Unless 3.2(3) applies, when a body or item of equipment is fitted to the chassis of a vehicle on or after 1 October 2005, the means by which it is attached must be designed and constructed so that the stresses on the attachment, when calculated in accordance with 3.2(2), do not exceed 60% of the yield stress of the material from which the attachment is made.
- 3.2(2) The stresses in 3.2(1) must be calculated under each of the following loading conditions, when the forces are applied at the approximate centre of gravity of the load:
- (a) a longitudinally-acting force, equivalent to twice the combined weight of the payload capacity and the body mass;
 - (b) a downward-acting force, equivalent to twice the combined weight of the payload capacity and the body mass;
 - (c) a transversely-acting force, equivalent to the combined weight of the payload capacity and the body mass;
 - (d) an upward-acting force, equivalent to the combined weight of the payload capacity and the body mass.
- 3.2(3) Subject to 9.1(3), logging bolster attachments fitted to a vehicle on or after 27 November 1998 must comply with the version of the *Bolster Attachment Code* in *Schedule 1* or *Schedule 2* or *Schedule 4* that applied at the time of fitting.

Clause 3.2(1): replaced, on 29 June 2007, by *clause 2.1* of *Land Transport Rule: Heavy Vehicles Amendment 2007*.

Clause 3.2(3): amended, on 1 October 2011, by *clause 2.1* of *Land Transport Rule: Heavy Vehicles Amendment (No 2) 2011*.

3.3 Cab-guards

- 3.3(1) A vehicle that is constructed for the purpose of transporting timber logs must be fitted with a cab-guard, if that vehicle has a cab.
- 3.3(2) A cab-guard and its attachment to a vehicle's chassis must be of adequate strength to protect the cab of the vehicle from forces that result from load impact during:
- (a) loading or unloading of the vehicle; and
 - (b) emergency braking of the vehicle at 1 g.
- 3.3(3) A cab-guard must be fitted to a vehicle's chassis in a way that:

- (a) does not adversely affect the strength and durability of the chassis; and
 - (b) does not cause the chassis to be damaged when the cab-guard is subjected to the forces in 3.3(2).
- 3.3(4) A cab-guard attached to a vehicle's chassis:
- (a) must be at least as wide as the cab of the vehicle; and
 - (b) must be at least as high as the cab of the vehicle; and
 - (c) must not have apertures of a shape and size that could allow any forward-moving portion of the vehicle's load to pass through the cab-guard.

3.4 Transmission

- 3.4(1) The transmission on a vehicle must be of adequate strength and have appropriate performance characteristics for all conditions of loading and operation for which the vehicle was constructed.
- 3.4(2) The transmission on a vehicle must be installed correctly, as determined by reference to the transmission manufacturer's instructions, and maintained within safe tolerance of its original condition.
- 3.4(3) A device fitted to a vehicle to restrict the field of swing of a driveshaft in the event of driveshaft failure must be maintained within safe tolerance of its original condition.

3.5 Axles

- 3.5(1) An axle fitted to a vehicle must be of adequate strength and have appropriate performance characteristics for all conditions of loading and operation for which the vehicle was constructed.
- 3.5(2) A device for altering the distribution of mass between axles must not be fitted to a vehicle, unless the device:
- (a) lifts an unpowered axle clear of the ground; or
 - (b) reduces the mass carried by an unpowered axle without lifting it clear of the ground; and
 - (i) has a control that is spring loaded, so that when the control is released the mass on the unpowered axle reverts to what it was before the operation of the controls; or

- (ii) has a control with an automatic timing device with an activation time of not more than two minutes after which the mass on the unpowered axle reverts automatically to what it was before the operation of the control, and with a non-activation time of at least 30 seconds during which the control cannot be activated again.

3.6 Suspension

- 3.6(1) The suspension system of a vehicle must be of adequate strength and have appropriate performance characteristics for all conditions of loading and operation for which the vehicle was constructed.
- 3.6(2) An axle-stop device fitted to a vehicle must be maintained within safe tolerance of its original condition.

3.7 Ballrace turntables

- 3.7(1) A ballrace turntable fitted to a vehicle must be securely fastened to the vehicle in accordance with the ballrace turntable manufacturer's instructions.
- 3.7(2) A ballrace turntable fitted to a vehicle must be maintained within safe tolerance of its original condition.

3.8 Electrical requirements

- 3.8(1) The voltage of the electrical systems and components in a vehicle must be suitable for all conditions of operation for which the vehicle was constructed.
- 3.8(2) The current ratings of electrical wires in a vehicle must not be exceeded.
- 3.8(3) Electrical wires in a vehicle must:
 - (a) be insulated and protected from damage that could be caused by water, fuel, oil, other fluids, dirt or heat; and
 - (b) if practicable, be clipped or otherwise gathered into looms with an insulated material.
- 3.8(4) Electrical wires and looms in a vehicle must:
 - (a) be appropriately and securely fastened to the vehicle to protect them from damage; and
 - (b) where they pass through holes in the vehicle structure, be protected from damage.

- 3.8(5) Electronic control devices of safety systems fitted to a vehicle must be protected from electrical interference that could adversely affect their operation.

3.9 Equipment locking devices

- 3.9(1) A sliding axle set or sliding chassis, or an outrigger fitted to a vehicle, must have an effective locking device so that other road users are not endangered by the inadvertent extension or separation of that equipment.
- 3.9(2) A vehicle fitted with a sliding axle set or a sliding chassis must either have a locking device that is able to be seen in a locked position, or be equipped with a visual or audible alarm to warn the driver if the equipment is not locked in one of the locking positions.
- 3.9(3) A vehicle of Class NB or Class NC that is fitted with a swivelling (or knuckle boom) crane for loading the vehicle or a trailer towed by the vehicle must:
- (a) be fitted with a locking device to each outrigger that is able to be seen in a locked position when an outrigger is retracted; or
 - (b) be equipped with a visual or audible alarm to warn the driver if an outrigger is not in the fully retracted position.
- 3.9(4) An alarm in 3.9(2) or 3.9(3)(b) must be visible or audible from the driver's seating position, and the alarm must operate when the vehicle's engine is running, except when the parking brake is fully applied or when the gear selector of a vehicle with an automatic transmission is in the 'park' position.
- 3.9(5) If the locking device in 3.9(1) incorporates a system that provides energy for its operation, the device must remain fully engaged in the locked position, or the locking action must be initiated immediately, if the energising system fails.
- 3.9(6) A sliding axle set or a sliding chassis must have endstops at the end of the slideway to prevent the separation of the sliding parts if the primary locking device fails.

Clause 3.9(2): replaced, on 29 June 2007, by clause 2.2 of Land Transport Rule: Heavy Vehicles Amendment 2007.

Clause 3.9(3): replaced, on 29 June 2007, by clause 2.2 of Land Transport Rule: Heavy Vehicles Amendment 2007.

Clause 3.9(4): replaced, on 29 June 2007, by clause 2.2 of Land Transport Rule: Heavy Vehicles Amendment 2007.

Section 4 Towing connection requirements

4.1 Vehicle and component requirements

- 4.1(1) Towing connection components fitted to a vehicle must ensure that a secure connection can be maintained between the towing and towed vehicles under all conditions of loading and operation for which the vehicle was constructed.
- 4.1(2) Tractors or agricultural trailers used principally for agricultural, land management or roading operations must comply with:
- (a) 4.2 ; or
 - (b) 4.4 to 4.8, as applicable.

4.2 Tractors and agricultural trailers

- 4.2(1) Towing connection components must be fit for purpose and in sound condition.
- 4.2(2) A coupling pin must:
- (a) be of a diameter that is appropriate for the diameter of the tractor or trailer coupling, whichever has the smaller diameter hole; and
 - (b) have a diameter that is not less than 75% of the diameter of the larger of the coupling holes; and
 - (c) have a retaining mechanism.
- 4.2(3) Tow-eyes must not be worn at any point more than the lesser of:
- (a) 10% of the original diameter; or
 - (b) the manufacturer's wear tolerance.
- 4.2(4) An agricultural trailer fitted with a towing connection other than a two-point or three-point linkage must have a safety chain permanently attached to it and that chain must:
- (a) have a breaking strength of at least the gross mass towed; and
 - (b) have its breaking strength identified; and
 - (c) be attached to the trailer by means other than by welding of the chain itself; and
 - (d) be adjustable in length to eliminate a tight or loose chain.
- 4.2(5) A tractor used to tow an agricultural trailer must have an attachment point to which a safety chain can be securely connected.

Clause 4.2(1): replaced, on 1 June 2013, by clause 2.1(1) of Land Transport Rule: Heavy Vehicles Amendment 2013.

Clause 4.2(2): replaced, on 1 June 2013, by clause 2.1(2) of Land Transport Rule: Heavy Vehicles Amendment 2013.

Clause 4.2(3): replaced, on 1 June 2013, by clause 2.1(3) of Land Transport Rule: Heavy Vehicles Amendment 2013.

Clause 4.2(4): replaced, on 1 June 2013, by clause 2.1(4) of Land Transport Rule: Heavy Vehicles Amendment 2013.

Clause 4.2(5): replaced, on 1 June 2013, by clause 2.1(5) of Land Transport Rule: Heavy Vehicles Amendment 2013.

4.3 Vehicle recovery service vehicles

- 4.3(1) Lifting gear fitted to a vehicle recovery service vehicle on or after 1 October 2005 must be constructed in accordance with:
- (a) *Australian Standard 1418.1-1994: Cranes (including hoists and winches) – General requirements; and*
 - (b) *Australian Standard 1418.5-1995: Cranes (including hoists and winches) – Mobile and vehicle-loading cranes; and*
 - (c) *Australian/New Zealand Standard: 1554, Structural steel welding Parts 1 to 6; and*
 - (d) *Australian Standard 3990-1993: Mechanical equipment – Steelwork.*
- 4.3(2) A towing connection fitted to the rear of a vehicle recovery service vehicle for recovery purposes on or after 1 October 2005 must be designed and constructed in accordance with *NZS 5446*.
- 4.3(3) A rigid tow-pole that is used for vehicle recovery purposes must be designed and constructed in accordance with *NZS 5446*.
- 4.3(4) Lifting gear of a Class NB hook truck, stinger lift truck or transporter must be able to satisfactorily complete a test lift of 1.25 times the lifting capacity stated by the manufacturer.
- 4.3(5) Lifting gear of a Class NC hook truck, stinger lift truck or transporter must be tested in accordance with *Australian Standard 1418.5-1995: Cranes (including hoists and winches) – Mobile and vehicle-loading cranes*.
- 4.3(6) The manufacturer's stated lifting capacity of a hook truck or stinger lift truck must, on or after 1 October 2005, be clearly displayed, in kilograms, at the rear of the vehicle in letters and figures not less than 30 mm high.

- 4.3(7) The manufacturer's stated lifting capacity in 4.3(6) must be rounded to the nearest 50 kg.
- 4.3(8) A component used in the construction of lifting gear fitted to a vehicle recovery service vehicle must be suitable for its intended use.

Clause 4.3(2): amended, on 28 April 2008, by clause 2.3(a) of Land Transport Rule: Heavy Vehicles Amendment 2008.

Clause 4.3(3): amended, on 28 April 2008, by clause 2.3(a) of Land Transport Rule: Heavy Vehicles Amendment 2008.

4.4 Drawbeams and towbars

- 4.4(1) A drawbeam fitted to a vehicle used in a combination must, unless 4.2, 4.3 or 4.4(2) applies, comply with NZS 5446.
- 4.4(2) A drawbeam fitted to a vehicle that, before 1 February 1989, was certified for compliance with the *Recommended Practice for Towing Connections* of the New Zealand Truck-Trailer Manufacturers' Federation in *Schedule 3* must, by the date of issue of the first certificate of fitness issued on or after 1 April 2006:
- (a) comply with *New Zealand Standard 5446: 1987, Code of Practice for Heavy Motor Vehicle Towing Connections: Drawbar Trailers*; or
 - (b) be replaced with a drawbeam that complies with *New Zealand Standard 5446: 1987, Code of Practice for Heavy Motor Vehicle Towing Connections: Drawbar Trailers*.
- 4.4(3) A drawbeam, fitted to a vehicle, that is modified or repaired on or after 1 April 2005 must comply with NZS 5446.
- 4.4(4) A towbar fitted to a vehicle before 1 April 2006 must comply with:
- (a) *New Zealand Standard 5467: 1993, Code of Practice for Light Trailers*; or
 - (b) *New Zealand Standard 5446: 1987, Code of Practice for Heavy Motor Vehicle Towing Connections: Drawbar Trailers*; or
 - (c) *New Zealand Standard 5446: 1987, Code of Practice for Heavy Motor Vehicle Towing Connections: Drawbar Trailers amended by Appendix A to Policy Statement 5* for towbars rated for a maximum towed mass of 2000 kg or less.

- 4.4(5) A towbar fitted to a vehicle on or after 1 April 2006 for towing a light trailer must comply with *New Zealand Standard 5467: 1993, Code of Practice for Light Trailers*.

Clause 4.4(1): amended, on 28 April 2008, by *clause 2.3(b)* of *Land Transport Rule: Heavy Vehicles Amendment 2008*.

Clause 4.4(3): amended, on 28 April 2008, by *clause 2.3(b)* of *Land Transport Rule: Heavy Vehicles Amendment 2008*.

4.5 Drawbars

- 4.5(1) A drawbar fitted to a vehicle used in a combination must, unless 4.2, or 4.5(2) applies, comply with *NZS 5446*.

- 4.5(2) A drawbar fitted to a vehicle that, before 1 February 1989, was certified for compliance with the *Recommended Practice for Towing Connections* of the New Zealand Truck-Trailer Manufacturers' Federation in *Schedule 3* must, by the date of issue of the first certificate of fitness issued on or after 1 April 2006:

- (a) comply with *New Zealand Standard 5446: 1987, Code of Practice for Heavy Motor Vehicle Towing Connections: Drawbar Trailers*; or
- (b) be replaced with a drawbar that complies with *New Zealand Standard 5446: 1987, Code of Practice for Heavy Motor Vehicle Towing Connections: Drawbar Trailers*.

- 4.5(3) A telescopic drawbar must have endstops or a secondary locking device to prevent separation if the primary locking device fails.

- 4.5(4) For a pole trailer that carries its load as a rigid single span secured to both the towing vehicle and the pole trailer, the maximum towed mass of the drawbar must be equal to or greater than the unladen mass of the pole trailer, and the certification plate attached to the drawbar must state that the maximum towed mass applies only when the trailer is unladen.

- 4.5(5) A drawbar, fitted to a vehicle, that is modified or repaired on or after 1 April 2005 must comply with *NZS 5446*.

Clause 4.5(1): amended, on 28 April 2008, by *clause 2.3(c)* of *Land Transport Rule: Heavy Vehicles Amendment 2008*.

Clause 4.5(5): amended, on 28 April 2008, by *clause 2.3(c)* of *Land Transport Rule: Heavy Vehicles Amendment 2008*.

4.6 Couplings

- 4.6(1) A coupling must have an effective locking device and a separate means of retaining this device in the locked position.

- 4.6(2) Locking of a coupling must be readily verifiable by visual inspection.
- 4.6(3) Unless 4.6(4) or 4.6(5) applies, a hook-type, pin-type or ball-and-socket-type coupling for towing a vehicle must comply with *NZS 5446*.
- 4.6(4) A 50 mm diameter tow ball fitted to a vehicle for towing a light trailer must comply with *New Zealand Standard 5232: 1993, Specification for Ball-and-Socket Type Trailer Couplings*.
- 4.6(5) A 1 7/8 inch diameter tow ball fitted to a vehicle for towing a light trailer must comply with the performance and marking requirements of *New Zealand Standard 5232: 1993, Specification for Ball-and-Socket Type Trailer Couplings*, except that the ball size marking must be 1 7/8.
- 4.6(6) A device fitted to the front of a vehicle to enable it to be recovered, together with its connection to the chassis, must be suitable for this purpose.

Clause 4.6(3): amended, on 28 April 2008, by clause 2.3(d) of Land Transport Rule: Heavy Vehicles Amendment 2008.

4.7 Fifth wheel assemblies

- 4.7(1) A vehicle that is constructed to tow a semi-trailer must be fitted with:
- (a) a 50 mm diameter fifth wheel that complies with 4.7(2) or 4.7(2A); or
 - (b) a 90 mm diameter fifth wheel that complies with 4.7(3) or 4.7(3A); or
 - (c) if the vehicle is certified for use in a dedicated combination, a tow ball that complies with *NZS 5446*.
- 4.7(2) A 50 mm diameter fifth wheel that is fitted to a vehicle must comply with:
- (a) *New Zealand Standard 5450:1989, Coupling Devices for Articulated Vehicles – Fifth Wheel Assemblies*; or
 - (b) all of the following:
 - (i) *Australian/New Zealand Standard 4968.1-2003: Heavy-road vehicles – Mechanical coupling between articulated vehicle combinations – Design criteria and selection requirements for fifth wheel, kingpin and associated equipment*; and

- (ii) *Australian/New Zealand Standard 4968.2/-2003: Heavy-road vehicles – Mechanical coupling between articulated vehicle combinations – Testing and installation of fifth wheel and associated equipment; and*
 - (iii) *Australian Standard 2174-2006: Articulated Vehicles – Mechanical coupling between prime movers and semitrailers – Interchangeability requirements.*
- 4.7(2A) Despite 4.7(2) and subject to 4.7(2B), an imported vehicle may, instead of complying with 4.7(2), have fitted as original equipment a 50 mm diameter fifth wheel that complies with *UN/ECE Regulation 55: Uniform Provisions Concerning the Approval of Mechanical Coupling Components of Combinations of Vehicles E/ECE/342/Rev.1/Add.54/Rev.1/E/ECE/TRANS/505.*
- 4.7(2B) A modification or repair to a 50 mm diameter fifth wheel that complies with 4.7(2A) must comply with 4.7(2)(a) or 4.7(2)(b).
- 4.7(3) Subject to 4.7(3A), a 90 mm diameter fifth wheel that is fitted to a vehicle must comply with:
- (a) *Australian Standard 1773-1996: Articulated Vehicles – Fifth Wheel Assemblies; and*
 - (b) *Australian Standard 1771-1996: Installation of Fifth Wheel and Turntable Assemblies; and*
 - (c) *Australian Standard 2174-1994: Articulated Vehicles – Mechanical coupling between prime movers and semitrailers – Interchangeability requirements.*
- 4.7(3A) A 90 mm diameter fifth wheel that is fitted to a vehicle on or after 29 December 2007 must comply with all of the following:
- (a) *Australian/New Zealand Standard 4968.1-2003: Heavy-road vehicles – Mechanical coupling between articulated vehicle combinations – Design criteria and selection requirements for fifth wheel, kingpin and associated equipment; and*
 - (b) *Australian/New Zealand Standard 4968.2-2003: Heavy-road vehicles – Mechanical coupling between articulated vehicle combinations – testing and installation of fifth wheel and associated equipment; and*
 - (c) *Australian Standard 2174-2006: Articulated Vehicles – Mechanical coupling between prime movers and semitrailers – Interchangeability requirements.*

- 4.7(4) A vehicle that is fitted with a 90 mm diameter fifth wheel must have, clearly displayed in a position readily visible from the position from which the release handle of the fifth wheel is operated, '90 mm fifth wheel', where '90' must be not less than 60 mm high.
- 4.7(5) A rigid fifth wheel fitted to a vehicle must be installed and maintained in accordance with the fifth-wheel manufacturer's instructions.
- 4.7(6) A vehicle may not be towed using a fifth wheel coupled to another fifth wheel.

Clause 4.7(1): replaced, on 28 April 2008, by clause 2.4 of Land Transport Rule: Heavy Vehicles Amendment 2008.

Clause 4.7(1)(a): amended, on 1 November 2014, by clause 2.2(1) of Land Transport Rule: Heavy Vehicles Amendment 2014.

Clause 4.7(1)(b): amended, on 1 November 2014, by clause 2.2(2) of Land Transport Rule: Heavy Vehicles Amendment 2014.

Clause 4.7(2): replaced, on 1 November 2014, by clause 2.2(3) of Land Transport Rule: Heavy Vehicles Amendment 2014.

Clause 4.7(2A): inserted, on 1 November 2014, by clause 2.2(4) of Land Transport Rule: Heavy Vehicles Amendment 2014.

Clause 4.7(2A): replaced, on 1 November 2015, by clause 2.1(3) of Land Transport Rule: Heavy Vehicles Amendment 2014.

Clause 4.7(2B): inserted, on 1 November 2014, by clause 2.2(4) of Land Transport Rule: Heavy Vehicles Amendment 2014.

Clause 4.7(2B): replaced, on 1 November 2015, by clause 2.1(4) of Land Transport Rule: Heavy Vehicles Amendment 2014.

Clause 4.7(3): amended, on 29 June 2007, by clause 2.3(1) of Land Transport Rule: Heavy Vehicles Amendment 2007.

Clause 4.7(3A): inserted, on 29 June 2007, by clause 2.3(2) of Land Transport Rule: Heavy Vehicles Amendment 2007.

Clause 4.7(3A): amended, on 1 November 2015, by clause 2.1(5) of Land Transport Rule: Heavy Vehicles Amendment 2015.

Clause 4.7(4): amended, on 29 June 2007, by clause 2.3(3) of Land Transport Rule: Heavy Vehicles Amendment 2007.

Clause 4.7(6): inserted, on 28 April 2008, by clause 2.4(b) of Land Transport Act: Heavy Vehicles Amendment 2008.

4.8 Skid plates and kingpins

- 4.8(1) A semi-trailer must:
- (a) be fitted with:
 - (i) a 50 mm diameter kingpin; or

- (ii) a 90 mm diameter kingpin; or
 - (iii) if the vehicle is certified for use in a dedicated combination, a socket that complies with NZS 5446;
 - (b) if fitted with a kingpin, be fitted with a skid plate; and
 - (c) comply with 4.8(2) to 4.8(5), as applicable.
- 4.8(2) A 50 mm diameter kingpin and associated skid plate fitted to a vehicle must comply with:
- (a) *New Zealand Standard 5451: 1989, Coupling Devices for Articulated Vehicles – Fifth Wheel Kingpins*; or
 - (b) all of the following:
 - (i) *Australian/New Zealand Standard 4968.1-2003: Heavy-road vehicles – Mechanical coupling between articulated vehicle combinations – Design criteria and selection requirements for fifth wheel, kingpin and associated equipment*; and
 - (ii) *Australian/New Zealand Standard 4968.3-2003: Heavy-road vehicles – Mechanical coupling between articulated vehicle combinations – Kingpins and associated equipment*; and
 - (iii) *Australian Standard 2174-2006: Articulated Vehicles – Mechanical coupling between prime movers and semitrailers – Interchangeability requirements*.
- 4.8(2A) Despite 4.8(2), and subject to 4.8(2B), an imported vehicle may, instead of complying with 4.8(2), have fitted as original equipment a 50 mm diameter kingpin and associated skid plate that complies with *UN/ECE Regulation 55: Uniform Provisions Concerning the Approval of Mechanical Coupling Components of Combinations of Vehicles E/ECE/324/Rev.1/Add.54/Rev.1/E/ECE/TRANS/505*.
- 4.8(2B) A modification or repair to a 50 mm diameter kingpin and associated skid plate that complies with 4.8(2A) must comply with 4.8(2)(a) or 4.8(2)(b).
- 4.8(3) Subject to 4.8(3A), a 90 mm diameter kingpin fitted to a vehicle must comply with:
- (a) *Australian Standard 2175-1995: Articulated Vehicles – Kingpins*; and

- (b) *Australian Standard 2174-1994: Articulated Vehicles – Mechanical coupling between prime movers and semitrailers – Interchangeability requirements.*
- 4.8(3A) A 90 mm diameter kingpin fitted to a vehicle on after 29 December 2007 must comply with all of the following:
- (a) *Australian/New Zealand Standard 4968.1-2003: Heavy-road vehicles – Mechanical coupling between articulated vehicle combinations – Design criteria and selection requirements for fifth wheel, kingpin and associated equipment; and*
- (b) *Australian/New Zealand Standard 4968.3-2003: Heavy-road vehicles – Mechanical coupling between articulated vehicle combinations – Kingpins and associated equipment; and*
- (c) *Australian Standard 2174-2006: Articulated Vehicles – Mechanical coupling between prime movers and semi-trailers – Interchangeability requirements.*
- 4.8(4) Subject to 4.8(4A), a skid plate fitted to a vehicle in connection with a 90 mm diameter kingpin must comply with *Australian Standard 4235-1994: Articulated Vehicles – Design Criteria for Fifth Wheel Skid Plates.*
- 4.8(4A) A skid plate fitted to a vehicle on or after 29 December 2007, in connection with a 90 mm diameter kingpin, must comply with all of the following:
- (a) *Australian/New Zealand Standard 4968.1-2003: Heavy-road vehicles – Mechanical coupling between articulated vehicle combinations – Design criteria and selection requirements for fifth wheel, kingpin and associated equipment; and*
- (b) *Australian/New Zealand Standard 4968.3-2003: Heavy-road vehicles – Mechanical coupling between articulated vehicle combinations – Kingpins and associated equipment.*
- 4.8(5) A vehicle that is fitted with a 90 mm diameter kingpin must have clearly displayed in a position readily visible at the lower right-hand side of the front end of the vehicle ‘90 mm kingpin’, where ‘90’ must be not less than 100 mm high.
- 4.8(6) A kingpin fitted to a vehicle must not have any cracks that can be detected by means of visual inspection.
- (a) [Revoked]

(b) [Revoked]

4.8(7) [Revoked]

4.8(8) [Revoked]

4.8(9) [Revoked]

Clause 4.8(1)(a)(iii): inserted, on 28 April 2008, by clause 2.5 of Land Transport Rule: Heavy Vehicles Amendment 2008.

Clause 4.8(1)(b): amended, on 1 April 2011, by clause 2.1(1) of Land Transport Rule: Heavy Vehicles Amendment 2011.

Clause 4.8(2): replaced, on 1 November 2015, by clause 2.2(1) of Land Transport Rule: Heavy Vehicles Amendment 2015.

Clause 4.8(2)(b)(ii): replaced, on 1 May 2021, by clause 2.1 of Land Transport Rule: Heavy Vehicles Amendment 2021.

Clause 4.8(2A): inserted, on 1 November 2015, by clause 2.2(2) of Land Transport Rule: Heavy Vehicles Amendment 2015.

Clause 4.8(2B): inserted, on 1 November 2015, by clause 2.2(2) of Land Transport Rule: Heavy Vehicles Amendment 2015.

Clause 4.8(3): amended, on 29 June 2007, by clause 2.4(1) of Land Transport Rule: Heavy Vehicles Amendment 2007.

Clause 4.8(3A): inserted, on 29 June 2007, by clause 2.4(2) of Land Transport Rule: Heavy Vehicles Amendment 2007.

Clause 4.8(3A): amended, on 1 November 2015, by clause 2.2(3) of Land Transport Rule: Heavy Vehicles Amendment 2015.

Clause 4.8(4): amended, on 29 June 2007, by clause 2.4(3) of Land Transport Rule: Heavy Vehicles Amendment 2007.

Clause 4.8(4A): inserted, on 29 June 2007, by clause 2.4(4) of Land Transport Rule: Heavy Vehicles Amendment 2007.

Clause 4.8(4A): amended, on 1 November 2015, by clause 2.2(4) of Land Transport Rule: Heavy Vehicles Amendment 2015.

Clause 4.8(5): amended, on 29 June 2007, by clause 2.4(5) of Land Transport Rule: Heavy Vehicles Amendment 2007.

Clause 4.8(6): amended, on 1 October 2011, by clause 2.2(a) of Land Transport Rule: Heavy Vehicles Amendment (No 2) 2011.

Clause 4.8(6)(a): revoked, on 1 October 2011, by clause 2.2(b) of Land Transport Rule: Heavy Vehicles Amendment (No 2) 2011.

Clause 4.8(6)(b): revoked, on 1 October 2011, by clause 2.2(b) of Land Transport Rule: Heavy Vehicles Amendment (No 2) 2011.

Clause 4.8(7): revoked, on 1 April 2011, by clause 2.1(2) of Land Transport Rule: Heavy Vehicles Amendment 2011.

Clause 4.8(8): revoked, on 1 April 2011, by clause 2.1(2) of Land Transport Rule: Heavy Vehicles Amendment 2011.

Clause 4.8(9): revoked, on 1 April 2011, by clause 2.1(2) of Land Transport Rule: Heavy Vehicles Amendment 2011.

Section 5 Load securing equipment requirements

5.1 Load securing equipment

- 5.1(1) A vehicle that is constructed to transport a load must be fitted with load securing equipment.
- 5.1(2) Load securing equipment that is fitted to a vehicle must be constructed to ensure that the load can be securely contained on the vehicle under all conditions of loading and operation for which the vehicle was constructed.

5.2 Containment by a vehicle body

- 5.2(1) The body of a vehicle, such as a tank body for transporting bulk liquid; a tipping body for transporting sand, grain or other bulk goods; or other types of body that are constructed to contain the transported goods without the use of lashings, chains or other devices, must be specifically designed to contain that type and size of load.
- 5.2(2) A tank body for transporting bulk liquids must, if necessary:
- (a) have sufficient transverse baffles, or similar devices, to prevent excessive longitudinal load-shifting that could adversely affect the tractive or braking performance of the vehicle; and
 - (b) have a cross-section shape, longitudinal baffles or similar devices, to prevent excessive transverse load-shifting that could destabilise the vehicle.

5.3 Stockcrates and stockcrate retention devices

- 5.3(1) A stockcrate and its retention device, if fitted to a vehicle with a gross vehicle mass of 6000 kg or more, and a monocoque stock trailer with a gross vehicle mass of 6000 kg or more, must comply with the requirements in 5.3.
- 5.3(2) A stockcrate and its retention devices and a monocoque stock trailer must be constructed in accordance with *New Zealand Standard 5413: 1993, Code of Practice for the Manufacture and Use of Stockcrates on Heavy Vehicles*.
- 5.3(3) Stockcrate anchorage points fitted to the deck of a vehicle must comply with *New Zealand Standard 5444: 1989, Load Anchorage Points for Heavy Vehicles*.

5.4 **Curtain-sided bodies**

5.4(1) If a vehicle has a curtain-sided body that is constructed to secure a load on a vehicle, each curtain and curtain anchorage system must:

- (a) have a manufacturer's load rating appropriate for all conditions of loading and operation of the vehicle; and
- (b) be clearly marked, with the manufacturer's load rating in kilograms per metre, in a position on the curtain that is readily accessible for inspection purposes.

5.4(2) The load rating of the curtain and curtain anchorage system in 5.4(1) must, subject to 5.4(3), be established as the maximum load with which the following conditions are complied:

- (a) relative to the plane in which the curtain lies when it is secured but without load placed against it, the maximum sideways deflection of the curtain does not exceed 100 mm, at any point, when the load is subjected to a uniform and sustained lateral acceleration of 0.5 g; and
- (b) the curtain and curtain anchorage system do not fail when the load is subjected to a uniform and sustained lateral acceleration of 1 g.

5.4(3) Despite 5.4(2), the load rating of the curtain and curtain anchorage system may also be established by a method developed by a heavy vehicle industry representative group and approved by the Director by means of a notice in the *Gazette*.

Clause 5.4(1): replaced, on 28 April 2008, by clause 2.6 of Land Transport Rule: Heavy Vehicles Amendment 2008.

Clause 5.4(3): amended, on 1 August 2008, by Part 2 of Schedule 3 of the Land Transport Management Amendment Act 2008.

Clause 5.4(3): amended, on 1 April 2021, by clause 10.2 of Land Transport Rule: Agency to Director (Consequential Changes) Amendment 2021.

5.5 **Load anchorage points**

5.5(1) Unless 5.2 to 5.4 applies, a vehicle must have load anchorage points that comply with *New Zealand Standard 5444: 1989, Load Anchorage Points for Heavy Vehicles*.

5.5(2) Unmodified load anchorage points fitted to an imported vehicle must comply with the standard specified in 5.5(1), except that, if compliance is established by calculation:

- (a) the welding does not have to be carried out as specified in that standard, provided that the welding is satisfactory as established by visual inspection by a person authorised by the Director under 2.2(1)(i) of *Land Transport Rule: Vehicle Standards Compliance 2002*; and
- (b) the weld design stresses allowed in accordance with that standard must be reduced by 25%.

Clause 5.5(2)(a): amended, on 1 August 2008, by Part 2 of Schedule 3 of the *Land Transport Management Amendment Act 2008*.

Clause 5.5(2)(a): amended, on 1 April 2021, by clause 10.3 of *Land Transport Rule: Agency to Director (Consequential Changes) Amendment 2021*.

5.6 Headboards, sideboards and tailboards

5.6(1) A headboard, sideboard or tailboard fitted to a vehicle for the purpose of restraining a load on that vehicle must be of adequate strength to withstand, without incurring permanent deformation, a horizontal force uniformly distributed over its vertical area equal to:

- (a) for lashed loads:
 - (i) for headboards, half the weight of the payload capacity; and
 - (ii) for sideboards and tailboards, a quarter of the weight of the payload capacity; and
- (b) for unlashed loads that are baulked or that occupy the entire deck of the vehicle:
 - (i) for headboards, the weight of the payload capacity; and
 - (ii) for sideboards and tailboards, half the weight of the payload capacity.

5.6(1A) Despite 5.6(1), for a headboard, tailboard or sideboard higher than 0.7 m above the main load-carrying platform, the horizontal forces in 5.6(1)(a) and (b) may be uniformly distributed over the vertical areas bound by a horizontal line no higher than 0.7 m above the main load-carrying platform and, if applicable, any mezzanine floor.

- 5.6(2) A headboard, sideboard or tailboard in 5.6(1) must be fitted to a vehicle in a way that ensures that the parts of the vehicle to which it is attached are able to withstand the forces exerted by the headboard, sideboard or tailboard without incurring permanent deformation.
- 5.6(3) A headboard in 5.6(1), fitted to a vehicle in New Zealand on or after 1 April 2006, must have a plate, clearly displayed in a visible and readily accessible position, marked with:
- (a) the headboard manufacturer's name; and
 - (b) the headboard manufacturer's load rating in kilograms rounded to the nearest 100 kg.

Clause 5.6(1A): inserted, on 29 June 2007, by clause 2.5 of Land Transport Rule: Heavy Vehicles Amendment 2007.

Section 6 Modification

6.1 General requirements for modification

- 6.1(1) *Section 6* applies to all modifications carried out on or after 1 April 2005.
- 6.1(2) A modification to a vehicle that may affect the safety of the vehicle's systems, components or equipment, or the overall safety of the vehicle, must not prevent the vehicle from complying with this rule.
- 6.1(3) If practicable, a modification to a vehicle must be carried out in accordance with instructions from the vehicle manufacturer and the manufacturer of any system, component or equipment being fitted to the vehicle.
- 6.1(4) A modification to a vehicle to which 6.2 to 6.6 apply must be carried out:
- (a) as specified by the manufacturer of the vehicle, if the manufacturer produces more than 1000 heavy motor vehicles in a year for a market where compliance with Australian, Japanese or UN/ECE standards, or standards of the United States of America, is compulsory; or
 - (b) in accordance with the specifications of a vehicle inspector or inspecting organisation appointed to carry out specialist inspection and certification activities.
- 6.1(5) A modification to a vehicle to which 6.2 to 6.6 apply must be carried out using a system, component or equipment that is suitable for automotive application.

6.2 Modification affecting engine and transmission

- 6.2(1) A modification to a vehicle must not result in the vehicle's engine or transmission becoming unsuitable for the conditions of loading and operation for which the vehicle is modified.
- 6.2(2) A modification to a vehicle must not adversely affect the performance of the vehicle's engine or transmission.
- 6.2(3) A modification to a vehicle that affects the performance of the vehicle's driveshaft must not result in the driveshaft manufacturer's specified limits being exceeded.

6.3 Modification affecting axles, suspension and steering

- 6.3(1) An axle, a suspension system, or an axle and suspension system that is modified, or that is fitted to a vehicle to replace the one fitted by the vehicle manufacturer, must have a load rating and performance characteristics that are suitable for all conditions of loading and operation for which the vehicle is modified.
- 6.3(2) If an axle of a vehicle is fitted with tyres in a way that results in the wheel track being altered beyond the vehicle manufacturer's specified limits, or the number of tyres fitted to an axle exceeds the number specified by the vehicle manufacturer, either:
- (a) a new axle load rating must be established; or
 - (b) the current axle load rating must be confirmed as being valid.
- 6.3(3) A second steering axle fitted to a vehicle must have a means of steering that is compatible with the existing steering components.
- 6.3(4) The steering system of a vehicle to which a second steering axle is fitted to form a twin-steer axle set must be suitable for operating a twin-steer axle set.

6.4 Modification affecting chassis

- 6.4(1) If a vehicle is modified by the addition, removal or relocation of an axle and suspension system, by the replacement of an axle or suspension system with a different type of axle or suspension system, or by the modification of its chassis:
- (a) a new chassis rating must be issued and a new certificate of loading obtained; or
 - (b) the current chassis rating must be confirmed as being valid.

- 6.4(2) If a vehicle is modified by fitting a hoist, crane, logging bolster, tipping body or other special equipment, which may result in increased stress to a localised area of the chassis or significant redistribution of the load over the chassis:
- (a) a new chassis rating must be issued and a new certificate of loading obtained; or
 - (b) the current chassis rating must be confirmed as being valid.
- 6.4(3) A modification to the chassis of a vehicle must be designed to stress levels:
- (a) as specified by the vehicle manufacturer; or
 - (b) in accordance with *Australian Standard – 3990-1993: Mechanical equipment – Steelwork*; or
 - (c) in accordance with *British Standard 7608:1993, Code of practice for fatigue design and assessment of steel structures*; or
 - (d) that are not higher, when the vehicle is loaded to its proposed new gross vehicle mass, than those of the chassis of the unmodified vehicle loaded to its current gross vehicle mass.
- 6.4(4) If the vehicle manufacturer does not prohibit the welding of the chassis members, then welding that is part of the modification of a chassis must be carried out:
- (a) as specified by the vehicle manufacturer; or
 - (b) in accordance with *Australian/New Zealand Standard: 1554, Structural steel welding Parts 1 to 6*.
- 6.5 Conversion of a vehicle to right-hand drive**
- 6.5(1) If a vehicle is converted from left-hand drive to right-hand drive:
- (a) if practicable, original equipment must be used; and
 - (b) non-original equipment must not be used unless approved by the vehicle manufacturer or a vehicle inspector or inspecting organisation appointed to carry out specialist inspection and certification activities; and
 - (c) the steering column must be transferred without altering the integrity of the column or its collapse mechanism; and

- (d) except when fixing mountings to the chassis or body of the vehicle, steering components must not be welded, unless:
 - (i) the welding is designed by the vehicle manufacturer or a vehicle inspector or inspecting organisation appointed to carry out specialist inspection and certification activities; and
 - (ii) appropriate non-destructive testing is carried out by a qualified person; and
 - (e) steering performance and characteristics must be maintained; and
 - (f) the parking brake, auxiliary brake, accelerator and clutch controls must be transferred to the right-hand side of the vehicle; and
 - (g) new mounting points for the parking brake, accelerator and clutch controls must be of equivalent strength to the original mounting points.
- 6.5(2) If a vehicle is converted from left-hand drive to right-hand drive:
- (a) the service brake control assembly must be transferred to the right-hand side of the vehicle; or
 - (b) the service brake pedal assembly must be transferred to the right-hand side of the vehicle and the motion of the brake pedal must be transmitted to the master cylinder or treadle valve by:
 - (i) a torque shaft; or
 - (ii) levers and rods.
- 6.5(3) For a vehicle to which 6.5(2)(b) applies, the master cylinder or the treadle valve and the mechanism that transfers the braking effort from the right-hand side to the left-hand side must be protected to ensure that the service brake can be activated only by the driver.
- 6.6 Conversion of a vehicle to dual steering**
- 6.6(1) A conversion to dual steering may be carried out only on a special purpose vehicle.
- 6.6(2) If a special purpose vehicle is converted to dual steering:
- (a) if practicable, original equipment must be used; and

- (b) non-original equipment must not be used unless approved by the vehicle manufacturer or a vehicle inspector or inspecting organisation appointed to carry out specialist inspection and certification activities; and
 - (c) except when fixing mountings to the chassis or body of the vehicle, steering components must not be welded, unless:
 - (i) the welding is designed by the vehicle manufacturer or a vehicle inspector or inspecting organisation appointed to carry out specialist inspection and certification activities; and
 - (ii) appropriate non-destructive testing is carried out; and
 - (d) steering performance and characteristics must be maintained; and
 - (e) new mounting points for the parking brake, accelerator and clutch controls must be of equivalent strength to the original mounting points.
- 6.6(3) If a special purpose vehicle is converted to dual steering:
- (a) the service brake control assembly must be replicated on the other side of the vehicle in a way that prevents the hydraulic or pneumatic line pressure from acting on the non-operating master cylinder or treadle valve; or
 - (b) the motion of the brake pedal must be transmitted to the master cylinder or treadle valve by:
 - (i) a torque shaft; or
 - (ii) levers and rods.
- 6.6(4) The steering motion on a special purpose vehicle that has been converted to dual steering may be transmitted by chain and sprocket or bevel gear boxes, if proper means are provided to eliminate backlash.

Section 7 Repair

- 7.1(1) A repair to a vehicle must comply with this rule and with *Land Transport Rule: Vehicle Repair 1998*.
- 7.1(2) A repair to the chassis of a vehicle or to a structural element of a monocoque body of a vehicle must be carried out:
- (a) as specified by the manufacturer of the vehicle, if the manufacturer produces more than 1000 heavy motor vehicles in a year for a market in which compliance with Australian, Japanese or UN/ECE standards, or standards of the United States of America, is compulsory; or
 - (b) in accordance with the specifications of a vehicle inspector or inspecting organisation appointed to carry out specialist inspection and certification activities; or
 - (c) by taking into account:
 - (i) any information that is relevant to the vehicle; and
 - (ii) the cause and type of failure; and
 - (iii) any established methods of repair.

Section 8 Responsibilities

8.1 Responsibilities of operators

A person who operates a vehicle must ensure that the vehicle complies with this rule.

8.2 Responsibilities of repairers

A person who repairs a vehicle must ensure that the repair:

- (a) does not prevent the vehicle from complying with this rule; and
- (b) is carried out in accordance with this rule and with *Land Transport Rule: Vehicle Repair 1998*.

8.3 Responsibilities of modifiers

A person who modifies a vehicle must:

- (a) ensure that the modification does not prevent the vehicle from complying with this rule; and
- (b) notify the operator if the vehicle must be inspected and, if necessary, certified, because there is reason to believe that:

- (i) the safety performance of the vehicle has been altered; or
- (ii) compliance with this rule has been affected.

8.4 Responsibilities of vehicle inspectors and inspecting organisations

- 8.4(1) A vehicle inspector or inspecting organisation appointed for the purposes of certificate of fitness inspection and certification must not certify a vehicle under *Land Transport Rule: Vehicle Standards Compliance 2002* if they have reason to believe that the vehicle does not comply with this rule.
- 8.4(2) A vehicle inspector or inspecting organisation appointed for the purposes of heavy vehicle specialist inspection and certification must not certify a specific aspect of a vehicle under *Land Transport Rule: Vehicle Standards Compliance 2002* if they have reason to believe that the specific aspect does not comply with the applicable requirements in this rule.
- 8.4(3) A vehicle inspector or inspecting organisation appointed for the purposes of heavy vehicle specialist inspection and certification may approve, in accordance with 6.5(1)(b) and 6.6(2)(b), any non-original equipment used in the conversion of a vehicle from left-hand drive to right-hand drive or in the conversion of a special purpose vehicle to dual steering.
- 8.4(4) A vehicle inspector or inspecting organisation, appointed for the purposes of heavy vehicle specialist inspection and certification, who inspects and certifies a modification carried out on a vehicle, must retain all relevant information, including supporting calculations, based on which compliance with this rule has been established.

8.5 Responsibilities of manufacturers and retailers

- 8.5(1) A person who manufactures, stocks or offers for sale a chassis assembly for use in a vehicle must provide, with the chassis assembly:
- (a) a plate or document that:
 - (i) identifies the particular chassis assembly and make and model of chassis assembly; and
 - (ii) states, as applicable, the permitted maximum axle mass, axle-set mass, gross vehicle mass, gross combination mass and maximum towed mass determined by the manufacturer; and

- (b) information in English regarding the maintenance and servicing of the chassis assembly; and
 - (c) instructions in English for the safe fitting of a body or equipment to the chassis assembly, in printed or electronic form, or clear and accurate information on where and how the body builder can obtain those instructions without cost.
- 8.5(2) A person who manufactures or offers for sale a vehicle must:
 - (a) ensure that the vehicle complies with this rule; and
 - (b) provide instructions to be followed by a person, who operates or maintains the vehicle, to ensure the safe operation of the vehicle.
- 8.5(3) A person who fits a body or equipment to a chassis assembly must:
 - (a) comply with the instructions provided under 8.5(1)(c); and
 - (b) ensure that the fitting of the body or equipment to the chassis assembly does not prevent the vehicle from complying with this rule; and
 - (c) provide instructions to be complied with by a person, who operates or maintains the vehicle, to ensure the safe operation of the vehicle.
- 8.5(4) A person who manufactures a vehicle may approve any non-original equipment used in the conversion of the vehicle from left-hand drive to right-hand drive or in the conversion of a special purpose vehicle to dual steering.
- 8.6 Functions and powers of the Director**
- 8.6(1) The Director or a person authorised by the Director under 8.6(2) may approve or determine a chassis rating.
- 8.6(2) The Director may appoint a person to approve or determine a chassis rating and may impose requirements and conditions as to the process of approval or determination of a chassis rating.
- 8.6(3) The Director may, by giving written notice, revoke a record of determination that a specific aspect of a vehicle complies with applicable requirements, if the Director is satisfied on reasonable grounds that the specific aspect does not comply with applicable requirements.

- 8.6(4) The Director may, in accordance with 5.4(3), approve by means of a notice in the *Gazette*, a method developed by a heavy vehicle industry representative group to establish the rating of a curtain and curtain anchorage system for the purpose of use in a curtain-sided body of a vehicle.

Heading to *clause 8.6*: amended, on 1 August 2008, by *Part 2 of Schedule 3 of the Land Transport Management Amendment Act 2008*.

Heading to *clause 8.6*: amended, on 1 April 2021, by *clause 10.4(1) of Land Transport Rule: Agency to Director (Consequential Changes) Amendment 2021*.

Clause 8.6(1): amended, on 1 August 2008, by *Part 2 of Schedule 3 of the Land Transport Management Amendment Act 2008*.

Clause 8.6(1): amended, on 1 April 2021, by *clause 10.4(2) of Land Transport Rule: Agency to Director (Consequential Changes) Amendment 2021*.

Clause 8.6(2): amended, on 1 August 2008, by *Part 2 of Schedule 3 of the Land Transport Management Amendment Act 2008*.

Clause 8.6(2): amended, on 1 April 2021, by *clause 10.4(3) of Land Transport Rule: Agency to Director (Consequential Changes) Amendment 2021*.

Clause 8.6(3): amended, on 1 August 2008, by *Part 2 of Schedule 3 of the Land Transport Management Amendment Act 2008*.

Clause 8.6(3): amended, on 1 April 2021, by *clause 10.4(4) of Land Transport Rule: Agency to Director (Consequential Changes) Amendment 2021*.

Clause 8.6(4): amended, on 1 August 2008, by *Part 2 of Schedule 3 of the Land Transport Management Amendment Act 2008*.

Clause 8.6(4): amended, on 1 April 2021, by *clause 10.4(5) of Land Transport Rule: Agency to Director (Consequential Changes) Amendment 2021*.

Section 9 Transitional provisions and savings

- 9.1(1) A goods vehicle first registered before 1 August 1987, the certificate of loading of which includes a gross mass that is 25% higher than the gross vehicle mass, may be operated with a gross mass up to 25% greater than its gross vehicle mass until it undergoes a repair to its chassis or monocoque body.
- 9.1(2) The operator of a goods vehicle first registered before 1 August 1987 that undergoes a repair that was necessary for reasons other than damage caused to its chassis or monocoque body by a crash must, immediately following the repair, obtain a new certificate of loading for the vehicle that shows a gross mass not greater than the gross vehicle mass of the vehicle.

- 9.1(3) Despite 3.2(3), logging bolster attachments exempted by notice in the *Gazette* from having to comply with a version of the *Bolster Attachment Code* in *Schedule 1* or *2* do not have to comply with the Code.
- 9.1(4) A trailer fitted before 27 November 1998 with load cells supporting log bolster attachments that have not been certified for compliance with a version of the *Bolster Attachment Code* in *Schedule 1* or *2* must:
- (a) in addition to the normal safety chain fitted to the bolster and any belly chains as otherwise required, have a second safety chain of at least 6000 kg minimum breaking strength per bolster fitted over the load and secured to anchorage points mounted directly on the chassis of the vehicle; and
 - (b) have load anchorage points of at least 6000 kg rated strength that comply with *New Zealand Standard 5444: 1989, Load Anchorage Points for Heavy Vehicles*.
- 9.1(5) A towing connection that was certified, in accordance with this Rule, to *New Zealand Standard 5446:1987* (superseded) before 30 November 2007 may continue to comply with and be certified to that standard until the towing connection is modified.

Clause 9.1(4): amended, on 29 June 2007, by *clause 2.5 of Land Transport Rule: Heavy Vehicles Amendment 2007*.

Clause 9.1(5): inserted, on 28 April 2008, by *clause 2.7 of Land Transport Rule: Heavy Vehicles Amendment 2008*.

Part 2

Definitions

Agency means the New Zealand Transport Agency established under *section 93* of the *Land Transport Management Act 2003*

Agricultural trailer means a trailer constructed to be operated in connection directly with the operation or management of a farm; but does not include a logging trailer.

Approved vehicle standard for the purpose of this rule, means a standard incorporated by reference in this rule.

Articulated vehicle means any motor vehicle with a semi-trailer attached, so that part of the semi-trailer is superimposed on the motor vehicle and a substantial part of the mass of the semi-trailer and of its load is borne by the motor vehicle.

Axle means one or more shafts, spindles, or bearings in the same vertical transverse plane by means of which, in conjunction with wheels mounted on those shafts, spindles, or bearings, a portion of the weight of the vehicle is transmitted to the roadway, and:

- (a) if two or more wheels of a motor vehicle are substantially in the same line transversely and some or all of them have separate axles, the axles of all those wheels are to be treated as one axle;
- (b) if the longitudinal centre-line of an axle of a motor vehicle is less than 1 m distant from the longitudinal centre-line of another axle, the two axles are to be treated as one axle ('a dual axle').

Axle mass means the lesser of:

- (a) the maximum mass that can be carried by the axle, including the mass of the axle, as determined by the axle manufacturer; or
- (b) the maximum mass that can be carried by the suspension system, including the mass of the axle, as determined by the suspension system manufacturer.

Axle set means a single axle set, a tandem axle set, a twin-steer axle set, a tri-axle set, or a quad-axle set.

Axle-stop device means a device to control the movement of the axle in the event of suspension failure.

Ballrace turntable means a device incorporating a low friction ball bearing fitted between two substantial structural components of a vehicle to enable rotational motion between those components about a vertical axis.

Body means the part of the vehicle that is designed for the use and accommodation of the occupants or to hold any goods.

Bolster Attachment Code means the *Bolster Attachment Code* of the Log Transport Safety Council, approved by the Director.

Brake control assembly means an assembly containing the brake pedal assembly, the master cylinder or treadle valve, and associated components.

Brake pedal assembly means an assembly containing the brake pedal and pedal pivot, pedal bracket, pedal return spring and associated components.

Cab-guard means a structure attached to a vehicle that provides protection to the cab occupants from the effects of load impact; and may include a headboard.

Certificate of loading means a certificate of loading issued under any regulation or rule made under the *Land Transport Act 1998*.

Certify has the same meaning as in *Land Transport Rule: Vehicle Standards Compliance 2002*.

Chassis means the structural lower part of a vehicle to which the running gear and, as applicable, engine, transmission, steering system and body may be attached.

Chassis assembly means a chassis with running gear attached and, as applicable, engine, transmission and steering system attached.

Chassis rating means:

- (a) for a vehicle first registered before 1 February 1989 that has not been modified on or after 1 April 2005, a set of data, containing the gross vehicle mass, gross combination (if applicable) and maximum towed mass (if applicable), approved or determined by the Agency or a person appointed by the Agency;
- (b) for a vehicle first registered on or after 1 February 1989 or a vehicle that has been modified on or after 1 April 2005, a set of data, containing the permitted maximum axle and/or axle-set masses (if available), gross vehicle mass, gross combination mass (if applicable) and maximum towed mass (if applicable), approved or determined by the Director or a person authorised by the Director.

Class in relation to vehicles, means a category of vehicle of one of the Groups A, L, M, N and T, as specified in *Table A: Vehicle classes*.

Combination vehicle means a towing vehicle in combination with one or more trailers or other motor vehicle that is being towed.

Construction means the manufacture, assembly, reassembly, or modification of a vehicle; and includes all acts and activities related or incidental to the construction of a vehicle.

Coupling means that part of a vehicle that is specifically designed to enable it to be connected to another vehicle; and does not include a structural member of the towing or towed vehicle.

Dedicated combination means a combination of vehicles certified for use in combination where both vehicles are affixed with a plate clearly and indelibly marked with the VIN or chassis number of the other vehicle.

Drawbar means an assembly of components, that includes: the trailer coupling that connects the trailer to the coupling of the towed vehicle; hinges (where applicable); and the structural and other related components between the trailer coupling and trailer bogie or chassis.

Drawbeam means the part of the towing vehicle to which a coupling is fitted to enable a heavy trailer to be connected; and includes the attached coupling.

Dual steering in relation to a vehicle, means the vehicle is able to be steered from both the left-hand and right-hand side of the vehicle.

Fifth wheel means a device fitted to a vehicle to enable a semi-trailer to be connected to it by means of a kingpin so that the semi-trailer may be towed.

g for the purpose of this rule, means an acceleration of 9.81 m/s².

Goods means all kinds of movable property; and includes articles sent by post, and animals.

Gross combination mass means, for a vehicle that is permitted to tow another vehicle, the maximum permitted combined mass of the towing vehicle and any combination of attached trailers or vehicles, determined by the vehicle manufacturer and approved by the Director, or determined by the Director.

Gross mass has the same meaning as in *Part 2 of Land Transport Rule: Vehicle Dimensions and Mass 2016*.

gross vehicle mass has the same meaning as in the *Land Transport Act 1998*

Headboard means the substantially vertical part of the forward end of a flat deck or curtain-sided body of a vehicle.

Heavy motor vehicle means a motor vehicle that:

- (a) is of Class MD3, MD4, ME, NB, NC, TC or TD; or
- (b) has a gross vehicle mass that exceeds 3500 kg and is not of a class specified in *Table A: Vehicle classes*.

Hook truck means a vehicle recovery service vehicle with a crane hoist that partially lifts the vehicle to be recovered, which is then towed in this position.

Kingpin means a pin attached to the skid plate of a semi-trailer and used for connecting the semi-trailer to the fifth wheel of a towing vehicle.

Lifting gear in relation to a vehicle recovery service vehicle, means any equipment used to lift another vehicle; and includes towing attachments.

Light trailer means a trailer that has a gross vehicle mass of 3500 kg or less.

Load includes part of a load; and:

- (a) includes covers, ropes, ties, blocks, tackles, barrows, or other equipment or objects used in the securing or containing of a load on a vehicle or the loading or unloading of a vehicle, whether or not any other load is on the vehicle; and
- (b) does not include animal wastes discharged from animals being carried on a vehicle at the time.

Load anchorage point means a device permanently attached to a vehicle to enable a load to be secured or attached to the vehicle.

Load rating means the maximum force that can be withstood without incurring any loss of structural capacity.

Load securing equipment means equipment or a device permanently fitted to a vehicle to secure, either by itself or in conjunction with other equipment or devices such as lashings, a load to a vehicle.

Load-sharing axle set means an axle set suspension system that has effective damping characteristics on all axles of the set and is built to divide the load between the tyres on the set so that no tyre carries a mass more than 10% greater than the mass it would carry if:

- (a) the load were divided in the axle set so that each tyre carries an equal load; or
- (b) the axle set is a tandem axle set comprising a twin-tyred axle and a large single-tyred axle and is built to divide the load between the tyres on the set so that:
 - (i) 60% of the load is borne by the twin-tyred axle and 40% of the load is borne by the large single-tyred axle; or
 - (ii) 55% of the load is borne by the twin-tyred axle and 45% of the load is borne by the large single-tyred axle.

Logging bolster means a vertically orientated member attached to a vehicle that is used to secure loads of timber logs.

Low volume vehicle means a make and model of a vehicle, of a class specified in Table A: Vehicle classes, other than Class MD3, MD4, ME, NB, NC, TC or TD, that is:

- (a) manufactured, assembled or scratch-built in quantities of 500 or less in any one year, and where the construction of the vehicle may directly or

indirectly affect compliance of the vehicle with any of the vehicle standards prescribed by New Zealand law; or

- (b) modified uniquely, or in quantities of 500 or less in any one year, in such a way that compliance of the vehicle, its structure, systems, components or equipment with a legal requirement relating to safety performance applicable at the time of the modification may be affected.

Manufacturer’s operating limits—

- (a) in relation to a vehicle, means the allowance provided by the vehicle manufacturer in terms of performance capability and dimensions, relative to the deterioration, malfunction or damage, beyond which the safe performance of the vehicle, as defined by the vehicle manufacturer, is compromised; and
- (b) in relation to a system, component or item of equipment incorporated in or attached to a vehicle, means the allowance provided by the system, component or equipment manufacturer in terms of performance capability and dimensions, relative to the deterioration, malfunction or damage, beyond which the safe performance of the system, component or item of equipment (and consequently the vehicle) is compromised.

Mass in relation to a vehicle, means the quantity of material contained in or on the vehicle that, when subjected to acceleration due to gravity, will exert downwards on a level surface a force that can be measured as the weight of the vehicle.

Maximum towed mass means the maximum permitted mass of all vehicles that may be towed behind a vehicle as determined by the manufacturer of the towing vehicle and approved by the Director.

Modify in relation to a vehicle, means to change the vehicle from its original state by altering, substituting, adding or removing any structure, system, component or equipment; but does not include repair.

Monocoque in relation to a vehicle, means that the chassis of the vehicle is integral to the body.

Motor vehicle has the same meaning as in *section 2(1) of the Land Transport Act 1998*.

Operate in relation to a vehicle, means to drive or use the vehicle on a road, or to cause or permit the vehicle to be on a road or to be driven on a road, whether or not the person is present with the vehicle.

Original equipment means equipment that is fitted by the vehicle manufacturer when the vehicle is manufactured; or equipment that is approved by the vehicle manufacturer for use in a specific vehicle type for a specific purpose.

Outrigger in relation to a vehicle that is fitted with a crane or hoist, means a device fitted to the vehicle that extends and stabilises the vehicle while the crane or hoist is in use.

Payload capacity means the gross vehicle mass of a vehicle less its unladen mass.

Pole trailer means a trailer that is attached to a towing vehicle by a telescoping or sliding pole, and is designed to support a common long load spanning between the trailer and the towing vehicle.

Quad-axle set means a set of four axles, where:

- (a) the centres of the first and fourth axles are spaced not less than 3.75 m and not more than 4 m apart; and
- (b) all axles contain an equal number of tyres; and
- (c) none of the axles is a single standard-tyred axle.

Repair means to restore a damaged or worn vehicle, its structure, systems, components or equipment; and includes the replacement of damaged or worn structures, systems, components or equipment with equivalent undamaged or new structures, systems, components or equipment.

Rigid tow-pole means an inflexible bar with a coupling at each end that can be connected to the coupling fitted to the rear of a vehicle recovery service vehicle and to the coupling fitted to the front of a vehicle to be recovered without lifting that vehicle.

Safe tolerance means the tolerance within which the safe performance of the vehicle, its structure, systems, components or equipment is not compromised, having regard to any manufacturer's operating limits.

Semi-trailer means a trailer, with only one axle set, that is partially superimposed on the towing vehicle so that a substantial part of the trailer and its load is borne by the towing vehicle.

Sideboard means the substantially vertical part of the side of a flat deck body of a vehicle.

Single axle set means either one axle or two axles having their centres spaced less than 1 m apart.

Skid plate means the plate structure forming part of the semi-trailer that houses the kingpin and that mounts on the coupler plate to form the connection between the towing vehicle and the semi-trailer.

Special purpose vehicle means a vehicle that is a street sweeper, refuse collector, weed sprayer or road marker.

Steering axle means the axle of a vehicle where the wheels can turn at an angle to the centre-line of the vehicle.

Stinger lift truck means a vehicle recovery service vehicle with an arm that partially lifts the vehicle to be recovered, which is then towed in this position.

Stockcrate means a container designed for transporting livestock, which can be secured to a vehicle.

Stockcrate retention device means one or more restraining devices or lashings to facilitate the attachment of the stockcrate to the deck or chassis of a vehicle.

Suspension system means a system that allows controlled and limited movement of an axle relative to the chassis or body of a vehicle; and includes a spring and damping system and any associated controls.

Tailboard means the substantially vertical part of the rear end of a flat deck or curtain-sided body of a vehicle.

Tandem axle set means an axle set comprising two axles having their centres spaced not less than 1 m and not more than 2 m apart.

Three-point linkage means, for a tractor or agricultural trailer, a towing connection that has three points of attachment.

Towbar means the part of the towing vehicle to which a coupling for a light trailer is connected.

Towing connection means the combination of components that enables one vehicle to tow or be towed by another vehicle; and includes a towbar, drawbar, drawbeam and coupling.

Traction engine has the same meaning as in *section 2(1)* of the *Land Transport Act 1998*.

Tractor means a motor vehicle (other than a traction engine) constructed principally for towing an agricultural trailer or powering agricultural implements.

Trailer means a vehicle without motive power that is capable of being drawn or propelled by a motor vehicle from which it is readily detachable; but does not include:

- (a) a side car attached to a motor cycle; or
- (b) a vehicle normally propelled by mechanical power while it is being temporarily towed without the use of its own power.

Transmission in relation to a motor vehicle, means the gearing system and related components, including a driveshaft, by which power is transmitted from the flywheel or the engine output shaft to the input shafts of the powered axles.

Transporter in relation to a vehicle recovery service vehicle, means a vehicle equipped with a tray body that:

- (a) can move back and be tilted so that the rear end of the tray rests on the ground; or

- (b) remains fixed and onto which the vehicle to be recovered is moved up ramps or lifted.

Tri-axle set means a set of three axles, where:

- (a) the centres of the first and third axles are spaced not less than 2 m (or 1.8 m in the case of a single standard-tyred axles) and not more than 3 m apart; and
- (b) all axles contain an equal number of tyres; and
- (c) [*Revoked*]

Twin-steer axle set means an axle set of two axles with single tyres, where both axles are connected to the same mechanism in order to steer similarly.

Two-point linkage means, for an agricultural trailer, a towing connection that has two points of attachment.

UN/ECE is an abbreviation for a regulation of the United Nations Economic Commission for Europe.

Unladen mass in relation to a vehicle, means the mass of the vehicle together with the fuel in its fuel system (if any) and the equipment and accessories on it that are necessary for its operation for the purpose for which it was designed.

Vehicle has the same meaning as in *section 2(1) of the Land Transport Act 1998*.

Vehicle inspector or **inspecting organisation** has the same meaning as in *Land Transport Rule: Vehicle Standards Compliance 2002*.

Vehicle recovery service vehicle means a vehicle used in a vehicle recovery service for towing or transporting on a road any motor vehicle; but does not include a vehicle that is not designed or adapted for the purpose of towing or carrying motor vehicles.

Vehicle identification number (VIN) means a group of letters and numbers, consisting of 17 characters, that is affixed to the vehicle and that complies with the requirements of one of the following:

- (a) *ISO 3779*; or
- (b) *Australian Design Rule 61/01*; or
- (c) *Chapter 565 of the Code of Federal Regulations 49*.

Part 2, Definitions, Agency: inserted, on 1 August 2008, by *Part 2 of Schedule 3 of the Land Transport Management Amendment Act 2008*.

Part 2, Definitions, Bolster Attachment Code: amended, on 1 August 2008, by *Part 2 of Schedule 3 of the Land Transport Management Amendment Act 2008*.

Part 2, Definitions, Bolster Attachment Code: amended, on 1 April 2021, by *clause 10.5(1) of Land Transport Rule: Agency to Director (Consequential Changes) Amendment 2021*

Part 2, Definitions, chassis rating: amended, on 1 August 2008, by *Part 2 of Schedule 3 of the Land Transport Management Amendment Act 2008*.

*Part 2, Definitions, **chassis rating**, paragraph (b):* amended, on 28 April 2008, by *clause 3.1 of Land Transport Rule: Heavy Vehicles Amendment 2008.*

*Part 2, Definitions, **chassis rating**:* amended, on 1 April 2021, by *clause 10.5(2) of Land Transport Rule: Agency to Director (Consequential Changes) Amendment 2021.*

*Part 2, Definitions, **dedicated combination**:* inserted, on 28 April 2008, by *clause 3.2 of Land Transport Rule: Heavy Vehicles Amendment 2008.*

*Part 2, Definitions, **Director**:* revoked, on 1 August 2008, by *Part 2 of Schedule 3 of the Land Transport Management Amendment Act 2008.*

*Part 2, Definitions, **gross combination mass**:* amended, on 1 August 2008, by *Part 2 of Schedule 3 of the Land Transport Management Amendment Act 2008.*

*Part 2, Definitions, **gross combination mass**:* amended, on 1 April 2021, by *clause 10.5(3) of Land Transport Rule: Agency to Director (Consequential Changes) Amendment 2021.*

*Part 2, Definitions, **gross mass**:* replaced, on 1 June 2019, by *clause 2.1 of Land Transport Rule: Heavy Vehicles Amendment 2019.*

*Part 2, Definitions, **gross vehicle mass**:* replaced, on 11 August 2017, by *Part 4 of Schedule 3 of the Land Transport Amendment Act 2017.*

*Part 2, Definitions, **low volume vehicle**:* inserted, on 1 April 2011, by *clause 3.1 of Land Transport Rule: Vehicle Standards Compliance Amendment 2011.*

*Part 2, Definitions, **maximum towed mass**:* amended, on 1 August 2008, by *Part 2 of Schedule 3 of the Land Transport Management Amendment Act 2008.*

*Part 2, Definitions, **maximum toward mass**:* amended on 1 April 2021, by *clause 10.5.(4) of Land Transport Rule: Agency to Director (Consequential Changes) Amendment 2021.*

*Part 2, Definitions, **quad-axle set**:* replaced, on 15 September 2005, by *clause 2.1(1) of Land Transport Rule: Heavy Vehicles Amendment 2005.*

*Part 2, Definitions, **tandem axle set**:* amended, on 15 September 2005, by *clause 2.2 of Land Transport Rule: Heavy Vehicles Amendment 2005.*

*Part 2, Definitions, **tri-axle set**:* replaced, on 15 September 2005, by *clause 2.1(2) of Land Transport Rule: Heavy Vehicles Amendment 2005.*

*Part 2, Definitions, **tri-axle set**:* amended, on 1 May 2021, by *clause 2.2 of Land Transport Rule: Heavy Vehicles Amendment 2021.*

*Part 2, Definitions, **twin-steer axle set**:* amended, on 1 December 2016, by *clause 2.1(1) of Land Transport Rule: Heavy Vehicles Amendment 2016.*

*Part 2, Definitions, **vehicle identification number (VIN)**:* inserted, on 28 April 2008, by *clause 3.2 of Land Transport Rule: Heavy Vehicles Amendment 2008.*

Table A—Vehicle classes

| Class | Description |
|---------------------------------|---|
| AA (Pedal cycle) | A vehicle designed to be propelled through a mechanism solely by human power. |
| AB (Power-assisted pedal cycle) | A pedal cycle to which is attached one or more auxiliary propulsion motors having a combined maximum power output not exceeding 300 watts. |
| LA (Moped with two wheels) | A motor vehicle (other than a power-assisted pedal cycle) that: <ul style="list-style-type: none"> (a) has two wheels; and (b) either: <ul style="list-style-type: none"> (i) has an engine cylinder capacity not exceeding 50 ml and a maximum speed not exceeding 50 km/h; or (ii) has a power source other than a piston engine and a maximum speed not exceeding 50 km/h. |
| LB (Moped with three wheels) | A motor vehicle (other than a power-assisted pedal cycle) that: <ul style="list-style-type: none"> (a) has three wheels; and (b) either: <ul style="list-style-type: none"> (i) has an engine cylinder capacity not exceeding 50 ml and a maximum speed not exceeding 50 km/h; or (ii) has a power source other than a piston engine and a maximum speed not exceeding 50 km/h. |
| LB 1 | A Class LB motor vehicle that has one wheel at the front and two wheels at the rear. |
| LB 2 | A Class LB motor vehicle that has two wheels at the front and one wheel at the rear. |
| LC (Motor cycle) | A motor vehicle that: <ul style="list-style-type: none"> (a) has two wheels; and (b) either: <ul style="list-style-type: none"> (i) has an engine cylinder capacity exceeding 50 ml; or (ii) has a maximum speed exceeding 50 km/h. |
| LD (Motor cycle and side-car) | A motor vehicle that: <ul style="list-style-type: none"> (a) has three wheels asymmetrically arranged in relation to the longitudinal median axis; and (b) either: <ul style="list-style-type: none"> (i) has an engine cylinder capacity exceeding 50 ml; or (ii) has a maximum speed exceeding 50 km/h. |
| Side-car | A car, box, or other receptacle attached to the side of a motor cycle and supported by a wheel. |
| LE (Motor tri-cycle) | A motor vehicle that: <ul style="list-style-type: none"> (a) has three wheels symmetrically arranged in relation to the |

| Class | Description |
|--|--|
| | <ul style="list-style-type: none"> longitudinal median axis; and (b) has a gross vehicle mass not exceeding one tonne; and (c) either: <ul style="list-style-type: none"> (i) has an engine cylinder capacity exceeding 50 ml; or (ii) has a maximum speed exceeding 50 km/h. |
| LE 1 | A Class LE motor vehicle that has one wheel at the front and two wheels at the rear. |
| LE 2 | A Class LE motor vehicle that has two wheels at the front and one wheel at the rear. |
| Passenger vehicle | <p>A motor vehicle that:</p> <ul style="list-style-type: none"> (a) is constructed primarily for the carriage of passengers; and (b) either: <ul style="list-style-type: none"> (i) has at least four wheels; or (ii) has three wheels and a gross vehicle mass exceeding one tonne. |
| MA (Passenger car) | A passenger vehicle (other than a Class MB or Class MC vehicle) that has not more than nine seating positions (including the driver's seating position). |
| MB (Forward control passenger vehicle) | <p>A passenger vehicle (other than a Class MC vehicle):</p> <ul style="list-style-type: none"> (a) that has not more than nine seating positions (including the driver's seating position); and (b) in which the centre of the steering wheel is in the forward quarter of the vehicle's total length. |
| MC (Off-road passenger vehicle) | <p>A passenger vehicle, designed with special features for off-road operation, that has not more than nine seating positions (including the driver's seating position), and that:</p> <ul style="list-style-type: none"> (a) has four-wheel drive; and (b) has at least four of the following characteristics when the vehicle is unladen on a level surface and the front wheels are parallel to the vehicle's longitudinal centre-line and the tyres are inflated to the vehicle manufacturer's recommended pressure: <ul style="list-style-type: none"> (i) an approach angle of not less than 28 degrees; (ii) a breakover angle of not less than 14 degrees; (iii) a departure angle of not less than 20 degrees; (iv) a running clearance of not less than 200 mm; (v) a front-axle clearance, rear-axle clearance, or suspension clearance of not less than 175 mm. |
| Omnibus | A passenger vehicle that has more than nine seating positions (including the driver's seating position). An omnibus comprising two or more nonseparable but articulated units shall be considered as a single vehicle. |
| MD (Light omnibus) | An omnibus that has a gross vehicle mass not exceeding 5 tonnes. |

| Class | Description |
|---------------------------|---|
| MD 1 | An omnibus that has a gross vehicle mass not exceeding 3.5 tonnes and not more than 12 seats. |
| MD 2 | An omnibus that has a gross vehicle mass not exceeding 3.5 tonnes and more than 12 seats. |
| MD 3 | An omnibus that has a gross vehicle mass exceeding 3.5 tonnes but not exceeding 4.5 tonnes. |
| MD 4 | An omnibus that has a gross vehicle mass exceeding 4.5 tonnes but not exceeding 5 tonnes. |
| ME (Heavy omnibus) | An omnibus that has a gross vehicle mass exceeding 5 tonnes. |
| Goods vehicle | <p>A motor vehicle that:</p> <p>(a) is constructed primarily for the carriage of goods; and</p> <p>(b) either:</p> <p>(i) has at least four wheels; or</p> <p>(ii) has three wheels and a gross vehicle mass exceeding one tonne.</p> <p>For the purpose of this description:</p> <p>(a) a vehicle that is constructed for both the carriage of goods and passengers shall be considered primarily for the carriage of goods if the number of seating positions multiplied by 68 kg is less than 50% of the difference between the gross vehicle mass and the unladen mass;</p> <p>(b) the equipment and installations carried on special purpose vehicles not designed for the carriage of passengers shall be considered to be goods;</p> <p>(c) a goods vehicle that has two or more non-separable but articulated units shall be considered to be a single vehicle.</p> |
| NA (Light goods vehicle) | A goods vehicle that has a gross vehicle mass not exceeding 3.5 tonnes. |
| NB (Medium goods vehicle) | A goods vehicle that has a gross vehicle mass exceeding 3.5 tonnes but not exceeding 12 tonnes. |
| NC (Heavy goods vehicle) | A goods vehicle that has a gross vehicle mass exceeding 12 tonnes. |
| Trailer | A vehicle without motive power that is constructed for the purpose of being drawn behind a motor vehicle. |
| TA (Very light trailer) | A single-axled trailer that has a gross vehicle mass not exceeding 0.75 tonnes. |
| TB (Light trailer) | A trailer (other than a Class TA trailer) that has a gross vehicle mass not exceeding 3.5 tonnes. |

| Class | Description |
|---------------------|---|
| TC (Medium trailer) | A trailer that has a gross vehicle mass exceeding 3.5 tonnes but not exceeding 10 tonnes. |
| TD (Heavy trailer) | A trailer that has a gross vehicle mass exceeding 10 tonnes. |

Table A, item relating to **Class AB (power-assisted pedal cycle)**: amended, on 1 April 2010, by clause 3.1 of *Land Transport Rule: Vehicle Standards Compliance Amendment 2010*.

Part 3 Schedules

Schedule 1 Bolster Attachment Code

Log Transport Safety Committee
(Issue 27 November 1998)

1.0 Introduction

1.1 Objective

The bolster attachment system shall be designed as a total system to ensure that all loads imposed, as specified below, are reacted back to the vehicle chassis.

In particular, the Certifying Engineer shall consider all connection systems to the chassis including, but not limited to: bolts and bolt groups, twistlocks, lashings, welded fabrications, load cells, bolster pivot pins, resilient mountings and intermediate structural members.

1.2 Certification life

It is expected that Design Certificates issued according to this Code should remain valid for a minimum of three years and a maximum of ten years.

It is permissible to use components within the bolster attachment system which may have design or service lives shorter than the life specified within the Design Certificate provided that:

- (a) the short life components are identified in detail in the Design Certificate; and
- (b) the detail in the Design Certificate, shall have a table showing component replacement dates; and
- (c) the Design Certificate table shall be signed off by a responsible person confirming that periodic replacement of such components has been properly carried out.

1.3 Proprietary components

Any proprietary components used for the purpose of bolster attachment shall be rated, approved and certified by their original manufacturer, or Certifying Engineer, as being fit for that purpose according to the loading provisions of this Code.

1.4 Repairs and modifications

Repairs and modifications to the bolster attachments should be undertaken by the original manufacturer or their authorised agent.

All modifications shall be recertified by a Certifying Engineer as in 2.8.

1.5 Vehicle and bolster identification

Individual bolsters shall be stamped indelibly labelled or marked to clearly identify their manufacturer, and serial number, and rated bolster load.

At least one tag per vehicle shall be fitted identifying the bolsters, bolster attachment, vehicle, and expiry date compatible with the requirements of NZS 5444.

2.0 Definitions

2.1 Vehicle payload

Vehicle payload shall equal the manufacturer's rated GVM minus tare, and shall not be distributed to exceed the rating on any individual component of the vehicle or vehicles.

Note: The equipment manufacturer has the right to nominate a maximum GVM less than the original vehicle manufacturer's GVM or any LTSA limitations.

2.2 Rated Bolster Load; LR

The Rated Bolster Load is the maximum payload that bolster may carry, and shall be the greater of:

- (a) the known load calculated as a share of the total payload for predictable configurations; or
- (b) where bolsters are loaded in a nominally equal manner or are loaded indeterminately; the bolster load shall be the total payload divided by the number of bolsters.

For different loading cases there may be different numbers of bolsters capable of resisting each load case specified. The bolster load shall be found by dividing by the number of bolsters resisting each loading case.

2.3 Bolster Assembly Mass; D

Bolster Assembly Mass, D shall be taken as the mass of the bolster and any other structure or securing hardware attached with the bolster.

2.4 Design Bolster Load: Static; L_{DS} Dynamic: L_{DF}

The Rated Bolster Load calculated in 2.2 above shall be increased to allow for maldistribution within the log payload by a maldistribution of payload factor for static loadings only.

$$M = 1.4$$

$$\text{So; } L_{DS} = M \times L_R + D \text{ and } L_{DF} = L_R + D$$

2.5 Loads

Where the term 'g' is used this shall be taken as $g = 9.81 \text{ N/kg}$. All other variables or quantities shall be taken as measured in SI units unless specified.

Dynamic loads expressed in this Code are given as (Fatigue) Dynamic Load Ranges from which Fatigue Stress Ranges can be calculated and compared with allowable stress ranges.

Static loads are expressed as peak static loads in either direction (ie, up/down, left/right, tension/compression) from which peak static stresses can be calculated and compared with allowable stress levels. All loads shall be applied independently of any other design loads (ie, none shall be considered simultaneous).

Also, fatigue cycle counts in each mode of loading shall be considered independent of every other mode.

The load cycles are therefore to be counted as though no other mode of loading exists.

2.6 Allowable Stresses and Stress Ranges

These shall be as defined by AS 3990:1993 or BS 5400 PT10 for both static and dynamic loadings.

For the dynamic condition the stress at 2×10^6 cycles is to be used, based on an expected 10-year life. Where applicable a probability of failure of 2.3% should be used. In certain cases, a higher probability of failure could be acceptable, for example, where fatigue cracking would not have serious consequences and where a crack could be easily located and repaired. It is permissible to use shorter design life or components with shorter design life provided that any such component is identified as per section 1.2.

Where any component is likely to be damaged, worn or distorted during normal operational wear and tear, the Engineer shall select a fatigue stress level, class or category appropriate to the probable damaged condition. The Engineer shall not base allowable stress levels upon the as-new undamaged condition.

At the discretion of the Certifying Engineer a maximum service life may be specified on the Design Certificate.

2.7

Load Centre

The Load Centre shall be assumed to exist at the geometric centroid of the area bounded by the bolster bed, inner faces of the stanchions and a horizontal line across the tips of the stanchions or extension pins, if fitted.

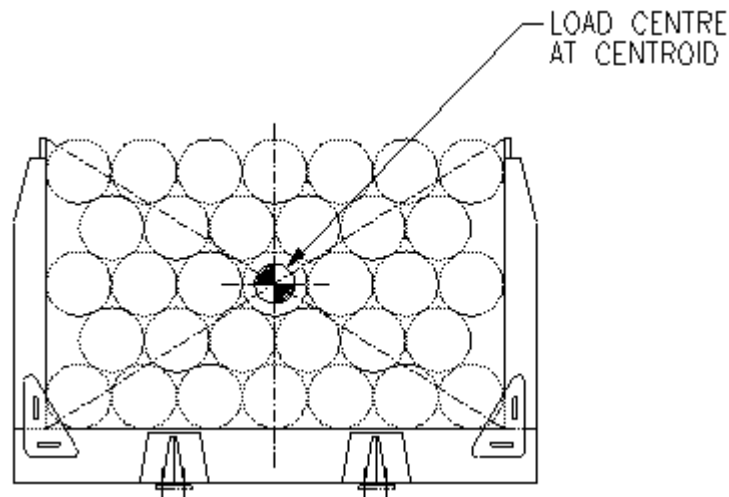

Figure 1

2.8

Certifying Engineer

The Certifying Engineer shall be approved by both the Land Transport Safety Authority **and** on the recommendation of the Log Transport Safety Committee.

3.0 Vertical loads

3.1 Application

The static and dynamic vertical loads shall be applied as a uniformly distributed load across the top of the bolster bed, equal in total to the values specified below.

Weight due to gravity shall be ignored for vertical loadings.

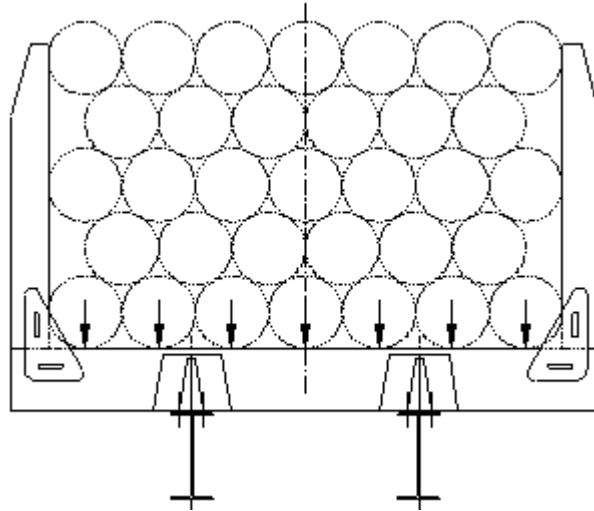

Figure 2

3.2 Static Vertical Load; P_v

Downwards: $P_v = L_{DS} \times 2.5 \text{ g}$

Upwards : $P_v = L_{DS} \times 1.0 \text{ g}$

3.3 Dynamic Vertical Load Range; Q_v

$Q_v = L_{DF} \times 2.0 \text{ g}$ (ie, $\pm 1.0 \text{ g}$)

4.0 Transverse loads

4.1 Application

The static and dynamic transverse loads shall be applied as forces at the load centre as in *Figure 3* below.

Weight due to gravity @ 1 g may be superimposed as a uniformly distributed load (UDL) across the bolster to help resist transverse loadings.

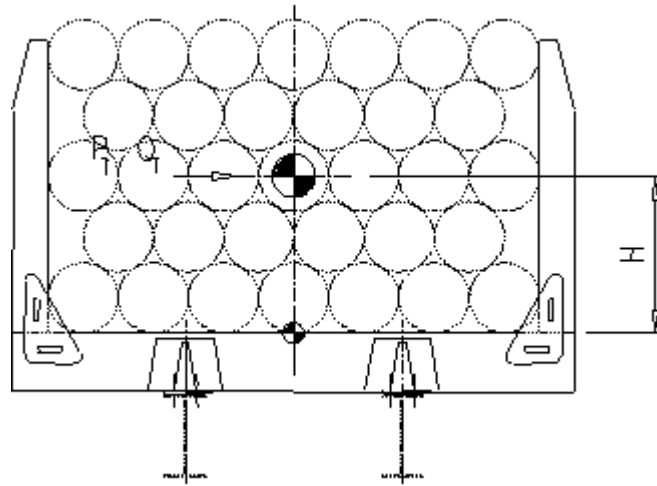

Figure 3

4.2 **Static Transverse Load; P_T (applies at the Load Centre)**

$$P_T = L_{DS} \times \pm 0.5 \text{ g}$$

4.3 **Dynamic Transverse Load; Q_T (applies at the Load Centre)**

$$Q_T = L_{DF} \times 2 \text{ g (ie, } \pm 1.0 \text{ g)}$$

5.0 **Longitudinal Loads**

5.1 **Application**

Longitudinal loading shall be checked in each of three cases

- 2 dynamic Q_{L1}, Q_{L2}
- 1 static P_L

as detailed below and weight due to gravity @ 1 g may be superimposed as a UDL across the bolster to help resist longitudinal loadings.

5.2 **Static Longitudinal Load; P_L**

$$P_L = L_{DS} \times \pm 1 \text{ g}$$

Applied 300 mm above bolster bed height.

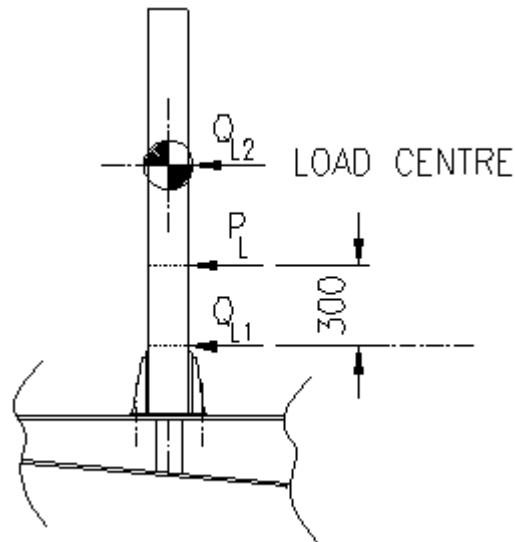

Figure 4

5.3 Dynamic Longitudinal Loads; Q_{L1} ; Q_{L2}

$$Q_{L1} = L_{DF} \times 3.0 \text{ g (ie, } \pm 1.5 \text{ g)}$$

Applied at Bolster Bed Height

$$Q_{L2} = L_{DF} \times 0.25 \text{ g (ie, } \pm 0.125 \text{ g)}$$

Applied at Load Centre

6.0 Special types of bolster mountings

The design loads specified in sections 3.0, 4.0 and 5.0 were specifically measured as being applicable to bolsters, of high torsional and bending stiffness, rigidly mounted onto a relatively flexible chassis structure.

A wide variety of configurations exists, and may expand in the future, where the connection between the bolster unit and chassis has some measure of compliance in torsion and/or linear location.

In recognition of the fact that:

- (a) not every configuration can be effectively tested; and
- (b) the impact and torsion induced loadings on such arrangements are significantly reduced, the Dynamic loadings Q_V , Q_T and Q_{L1} and Q_{L2} (as defined in 3.0, 4.0 and 5.0) shall be reduced as follows:
 - (i) for all bolts and fasteners the dynamic loads shall be reduced by 50%;

- (ii) for all other parts of the restraint system the dynamic loads shall be taken as zero.

The reduced dynamic loadings shall only apply to the following types of bolster attachment as defined below. Physical testing may be required to confirm compliance with these definitions.

6.1 Torsionally independent bolsters

Typically bolster types relying upon either gravity or resiliently restrained bolts to resist the longitudinal loads. The main connection to the chassis allows torsional displacement of the chassis rails without loading of the bolster bed through the attachment.

A minimum total of 2 degrees angular displacement between the two chassis rails in the longitudinal vertical plane (see *Figure 5*), with an increase in contact loads not exceeding 10kNm/degree between bolster and chassis members, shall be achieved.

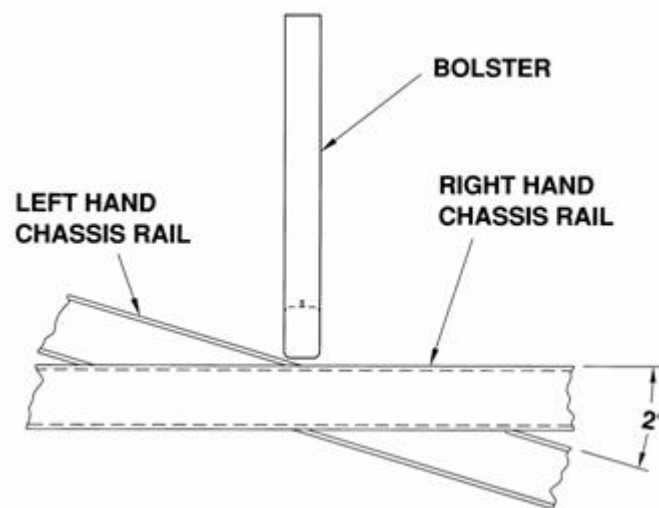

Figure 5—Torsionally Independent Bolster Attachments: Angular displacement required (not to scale)

6.2 Sliding bolsters

Bolsters mounted on sliding connections where the longitudinal position can adjust with load movement and sufficient clearance exists to meet a minimum ± 1 degrees angular displacement (see *Figure 6*).

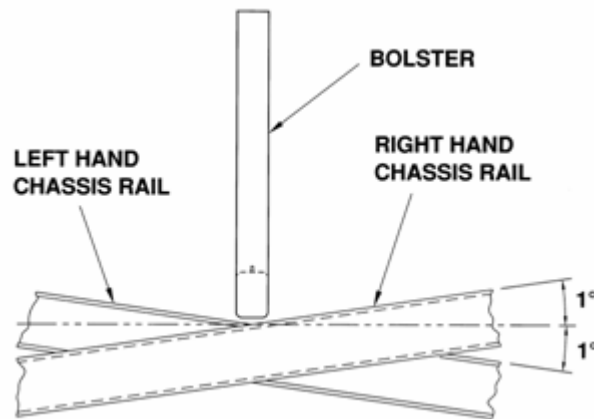

Figure 6—Sliding and Resilient Bolster Attachments: Angular displacement required (not to scale)

6.3 Resiliently mounted bolsters

Bolsters located in resilient mountings where the incremental stiffness of the total bolster location does not exceed 10MN/m for linear displacement in any direction and incremental torsional stiffness of 20kNm/degree of torsional angular displacement across chassis rails for a ± 1 degree minimum displacement as defined in 6.2 above (see *Figure 6*).

Typically these bolsters will be elastomeric or metal spring mounted with overriding solid connections to prevent excessive displacement.

The term 'incremental stiffness' is intended to allow for preloading of resilient mounts such that static deflections under rated loads can be minimised, whilst maintaining relatively low natural frequencies at the loaded condition.

7.0 Design of bolted connections

7.1 For some detail arrangements of bolster attachments, some bolted connections may rely on the provision and maintenance of pre-tensioned axial loads to avoid premature failure of the bolt(s) or joint. In such critical applications the manufacturer and/or Certifying Engineer shall specify and ensure the provision of:

- (a) correct bolt size, grade, type, thread form;
- (b) installation procedure (eg, torques, tightening procedures);
- (b) retention devices or system to retain nuts, studs;

- (c) data plate permanently fixed to the vehicle close to the bolts and detailing information a, b and c above.

Bolt design shall be undertaken by the following means:

- (a) by the manufacturer of proprietary specialised components (eg, load cell manufacturer) by design calculation and/or testing to the loading provisions of this Code, where applicable; otherwise
either
- (b) AS 3990:1993 with reference to Appendix F;
or
- (c) BS 7608:1993.

8.0 Secondary attachment devices

Where an existing primary attachment does not meet the requirements of this Code it is permissible to fit a secondary independent bolster attachment system to ensure restraint of the bolster should the primary system fail. The secondary attachment device is permissible for bolsters manufactured and fitted to vehicles before the introduction of this Code.

The secondary system shall:

- (a) be capable of meeting the load and stress requirements of clauses 3.2, 4.2, 5.2 and clause 2.6 for static loadings only;
and
- (b) be used only to provide emergency restraint to the bolster(s) until repair of the primary system is immediately and permanently repaired;
and
- (c) restraining the bolster in position under load, not exceeding 10 mm linear displacement in any direction, or ± 5 degrees angular displacement, from the normal unloaded bolster position.

Schedule 2

Bolster Attachment Code

Log Transport Safety Council (Revision 1 May 2001)

1. Introduction

1.1 Objective

The bolster attachment system shall be designed as a total system to ensure that all loads imposed, as specified below, are reacted back to the vehicle chassis.

In particular, the Certifying Engineer shall consider all connection systems to the chassis including, but not limited to: bolts and bolt groups, twistlocks, lashings, welded fabrications, load cells, bolster pivot pins, resilient mountings and intermediate structural members. The designer shall also consider the loads the design imposes on the chassis and the bolster.

1.2 Certification life

It is expected that Design Certificates issued according to this Code should remain valid for a minimum of three years and a maximum of ten years. Samples of acceptable forms for compliance certificates are shown in the Appendix to this Code.

It is permissible to use components within the bolster attachment system which may have design or service lives shorter than the life specified within the Design Certificate provided that:

- (a) the short life components are identified in detail in the Design Certificate;
and
- (b) the detail in the Design Certificate shall have a table showing component replacement dates;
and
- (c) the Design Certificate table shall be signed off by a responsible person confirming that periodic replacement of such components has been properly carried out.

1.3 Proprietary components

Any proprietary components used for the purpose of bolster attachment shall be rated, approved and certified by their original manufacturer, or Certifying Engineer, as being fit for that purpose according to the loading provisions of this Code.

1.4 Repairs and modifications

Repairs and modifications to the bolster attachments should be undertaken by the original manufacturer or their authorised agent.

All modifications shall be recertified by a Certifying Engineer as in 2.8.

1.5 Vehicle and bolster identification

Individual bolsters shall be stamped, indelibly labelled or marked to clearly identify their serial number.

Individual bolster mounts shall be stamped, indelibly labelled or marked to clearly identify their serial number.

At least one tag per vehicle shall be fitted identifying the bolsters, bolster attachments, bolster rating, the certifier, the manufacturer, vehicle, and expiry date compatible with the requirements of NZS 5444.

2. Definitions

2.1 Vehicle payload

Vehicle payload shall equal the manufacturer's rated GVM minus tare, and shall not be distributed to exceed the rating on any individual component of the vehicle or vehicles.

Note: The equipment manufacturer has the right to nominate a maximum GVM less than the original vehicle manufacturer's GVM or any LTSA limitations.

2.2 Rated Bolster Load; L_R

The Rated Bolster Load is the maximum payload that the bolster may carry, and shall be the greater of:

- (a) the known load calculated as a share of the total payload for predictable configurations; or
- (b) where bolsters are loaded in a nominally equal manner or are loaded indeterminately; the bolster

load shall be the total payload divided by the number of bolsters.

For different loading cases there may be different numbers of bolsters capable of resisting each load case specified. The bolster load shall be found by dividing by the number of bolsters resisting each loading case.

2.3 Bolster Assembly Mass; D

Bolster Assembly Mass, D shall be taken as the mass of the bolster and any other structure or securing hardware attached with the bolster.

2.4 Design Bolster Load: Static: L_{DS} Dynamic: L_{DF}

8.1.2 The Rated Bolster Load calculated in 2.2 above shall be increased to allow for maldistribution within the log payload by a maldistribution of payload factor, M, for static loadings only, where:

$M = 1.2$ for all static loads on long bolsters

$M = 1.2$ longitudinal loading calculations

$M = 1.4$ otherwise

So; $L_{DS} = M \times L_R + D$ and $L_{DF} = L_R + D$

2.5 Loads

Where the term 'g' is used this shall be taken as $g = 9.81 \text{ m/s}^2$. All other variables or quantities shall be taken as measured in SI units unless specified.

Dynamic loads expressed in this Code are given as (Fatigue) Dynamic Load Ranges from which Fatigue Stress Ranges can be calculated and compared with allowable stress ranges.

Static loads are expressed as peak static loads in either direction (ie, up/down, left/right, tension/compression) from which peak static stresses can be calculated and compared with allowable stress levels. All loads shall be applied independently of any other design loads (ie, none shall be considered simultaneous).

Also, fatigue cycle counts in each mode of loading shall be considered independent of every other mode.

The load cycles are therefore to be counted as though no other mode of loading exists.

2.6 General design requirements

Design shall be to AS 3990:1993 for both static and dynamic loadings or alternatively to AS 3990:1993 for static loading and to BS 5400 PT10 or BS 7608:1993 for dynamic loading.

Guidance on allowable stresses for materials other than those permitted under these standards should be sought from reputable internationally recognised Standards.

For the dynamic condition the stress at 2×10^6 cycles is to be used (in AS 3990:1993, loading condition 3 applies), based on an expected 10-year life. Where applicable a probability of failure of 2.3% should be used. In certain cases, a higher probability of failure could be acceptable, for example, where fatigue cracking would not have serious consequences and where a crack could be easily located and repaired. It is permissible to use shorter design life or components with shorter design life provided that any such component is identified as per section 1.2.

Where any component is likely to be damaged, worn or distorted during normal operational wear and tear, the Engineer shall select a fatigue stress level, class or category appropriate to the probable damaged condition. The Engineer shall not base allowable stress levels upon the as-new undamaged condition.

At the discretion of the Certifying Engineer a maximum service life may be specified on the Design Certificate.

2.7 Load Centre

The Load Centre shall be assumed to exist at the geometric centroid of the area bounded by the bolster bed, inner faces of the stanchions and a horizontal line across the tips of the stanchions or extension pins, if fitted.

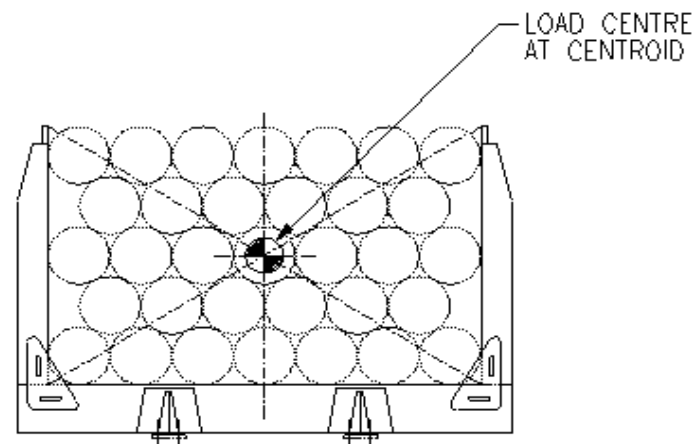

Figure 1—Determination of the load centre position

2.8 Certifying Engineer

The Certifying Engineer shall be approved by the Land Transport Safety Authority on the recommendation of the Log Transport Safety Council.

3. Vertical loads

3.1 Application

The static and dynamic vertical loads shall be applied as a uniformly distributed load across the top of the bolster bed, equal in total to the values specified below.

The weight of the bolster and attachments may be ignored for vertical loadings.

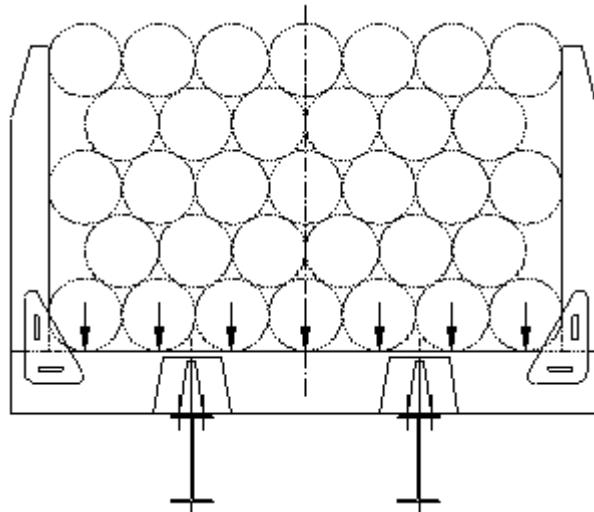

Figure 2—Application of vertical loads

3.2 Static Vertical Load; P_V

Downwards: $P_V = L_{DS} \times 2.5 \text{ g}$

Upwards: $P_V = L_{DS} \times 0.5 \text{ g}$

3.3 Dynamic Vertical Load Range; Q_V

$Q_V = L_{DF} \times 2.0 \text{ g}$ (ie, $\pm 1.0 \text{ g}$)

4. Transverse loads

4.1 Application

The static and dynamic transverse loads shall be applied as forces at the load centre as in *Figure 3* below.

Weight due to gravity @ 1 g may be superimposed as a uniformly distributed load (UDL) across the bolster to help resist transverse loadings.

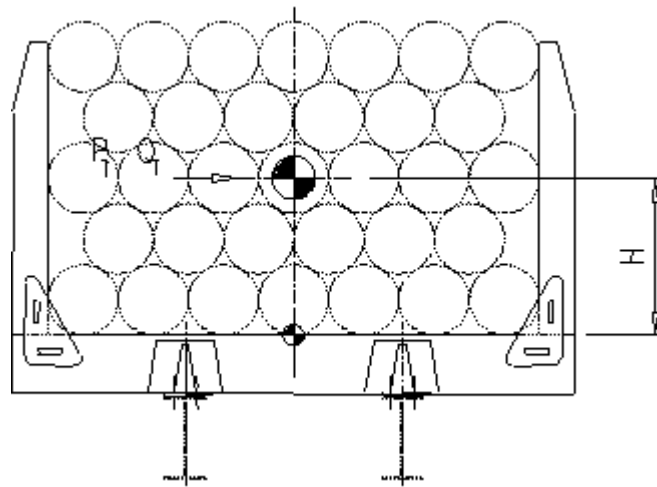

Figure 3—Application of transverse loads

4.2 **Static Transverse Load; P_T (applies at the Load Centre)**

$$P_T = L_{DS} \times \pm 0.5 \text{ g}$$

4.3 **Dynamic Transverse Load; Q_T (applies at the Load Centre)**

$$Q_T = L_{DF} \times 1.7 \text{ g (ie, } \pm 0.85 \text{ g)}$$

5. **Longitudinal loads**

5.1 **Application**

Longitudinal loading shall be checked in each of four cases

- 2 dynamic Q_{L1} , Q_{L2}

- 2 static P_{LF} , P_{LR}

as detailed below and weight due to gravity @ 1 g may be superimposed as a UDL across the bolster to help resist longitudinal loadings.

5.2 **Static Longitudinal Loads; P_{LF} , P_{LR}**

Forwards: $P_{LF} = L_{DS} \times 1 \text{ g}$

Applied 300 mm above bolster bed height.

Rearwards: $P_{LR} = L_{DS} \times 0.5 \text{ g}$

Applied at the bolster bed height.

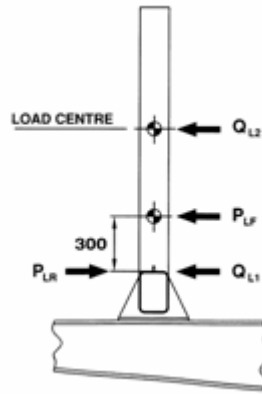

Figure 4—Application of longitudinal loads

5.3 Dynamic Longitudinal Loads; Q_{L1} ; Q_{L2}

$$Q_{L1} = L_{DF} \times 2.0 \text{ g (ie, } \pm 1.0 \text{ g)}$$

Applied at Bolster Bed Height

$$Q_{L2} = L_{DF} \times 0.25 \text{ g (ie, } \pm 0.125 \text{ g)}$$

Applied at Load Centre

6. Special types of bolster mountings

The design loads specified in sections 3.0, 4.0 and 5.0 were specifically measured as being applicable to bolsters, of high torsional and bending stiffness, rigidly mounted onto a relatively flexible chassis structure.

A wide variety of configurations exists, and may expand in the future, where the connection between the bolster unit and chassis has some measure of compliance in torsion and/or linear location.

In recognition of the fact that:

- (a) not every configuration can be effectively tested; and
- (b) the impact and torsion induced loadings on such arrangements are significantly reduced, the Dynamic loadings Q_V , Q_T and Q_{L1} and Q_{L2} (as defined in 3.0, 4.0 and 5.0) shall be reduced as follows:
 - (i) for all bolts and fasteners the dynamic loads shall be reduced by 50%;
 - (ii) for welds the dynamic loads may be taken as being sufficiently low as not to require detailed fatigue design. However, dynamic

loads do exist and good fatigue detail design practice should be followed;

- (iii) for all other parts of the restraint system the dynamic loads may be taken as zero. Good fatigue detail design practice should be followed.

The reduced dynamic loadings shall only apply to the following types of bolster attachment as defined below. Physical testing may be required to confirm compliance with these definitions.

6.1 Torsionally independent bolsters

Typically bolster types relying upon either gravity or resiliently restrained bolts to resist the longitudinal loads. The main connection to the chassis allows torsional displacement of the chassis rails without loading of the bolster bed through the attachment.

A minimum total of 2 degrees angular displacement between the bolster and each chassis rail in the longitudinal vertical plane (see *Figure 5*), with an increase in contact loads not exceeding 10kNm/degree between bolster and chassis members, shall be achieved.

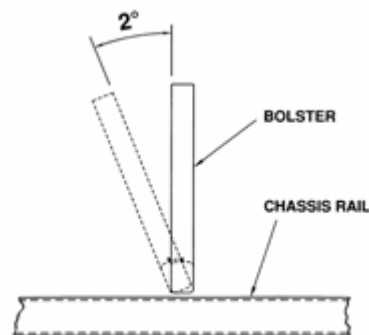

Figure 5—Angular displacement requirement for torsionally independent bolster attachments (not to scale)

6.2 Sliding bolsters

Bolsters mounted on sliding attachments where sufficient clearance exists to meet a minimum ± 1 degrees angular displacement (see *Figure 6*), with an increase in contact loads not exceeding 20kNm/degree between bolster and chassis members.

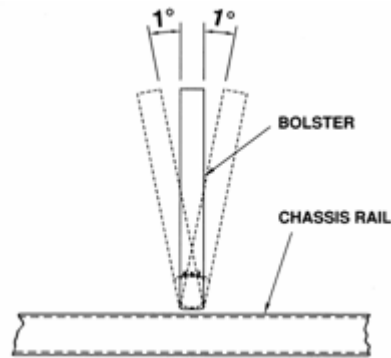

Figure 6—Angular displacement requirement for sliding and resilient bolster attachments (not to scale)

6.3 Resiliently mounted bolsters

Resiliently mounted bolsters are those for which the incremental rotational stiffness does not exceed 20kNm/degree (per attachment) for an angular displacement of ± 1 degree about the transverse axis (see *Figure 6*).

Typically these bolsters will be elastomeric or metal spring mounted with overriding solid connections to prevent excessive displacement.

The term 'incremental stiffness' is intended to allow for preloading of resilient mounts such that static deflections under rated loads can be minimised, whilst maintaining relatively low natural frequencies at the loaded condition.

6.4 Longs bolsters

Bolster mounts that are designed to carry logs suspended between separate vehicles (eg, truck and trailer or two trailers etc) have special requirements, as detailed in this section of the Code. Bolster attachments used in both long and short log applications shall be certified and rated for each application.

The bolster shall be able to rotate fore and aft about its transverse axis by at least $\pm 5^\circ$ where the incremental stiffness of the bolster attachment does not exceed 20kNm/degree of angular displacement (see *Figure 7*).

Side to side rotation of the bolster about the longitudinal axis of the vehicle shall be minimised to avoid instability.

Provision shall be made for the bolster to rotate about its vertical axis. This may be done utilising a standard trailer dolly ballrace turntable or slewing. The Engineer shall justify the rating of the ballrace turntable or slewing by applying the turntable manufacturer's requirements for the longs logging application

using the static loadings specified in sections 3, 4 and 5 and the reduced dynamic loadings specified in 6.0.

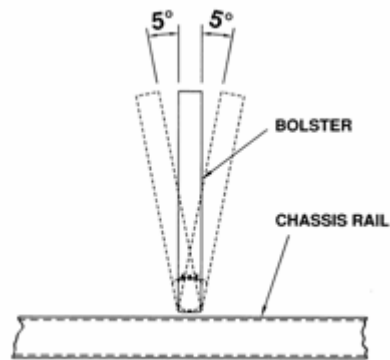

Figure 7—Angular displacement requirement for long bolster attachments (not to scale)

In the absence of these requirements, the design bolster load, L_{DF} shall not exceed 1.25 times the manufacturer's static vertical rating for the turntable or slewring when used on a trailer dolly.

The ballrace turntable or slewring shall be supported over at least 50% of the circumferential area of both top and bottom rings, with detailed design of the bolting being carried out by the Engineer.

Where ballrace turntables or slewrings designed for trailer dollies are not used, the loads specified in sections 3, 4, 5 and 6 of this Code shall be applied.

7. Design of bolted connections

For some detail arrangements of bolster attachments, some bolted connections may rely on the provision and maintenance of pre-tensioned axial loads to avoid premature failure of the bolt(s) or joint. In such critical applications the manufacturer and/or Certifying Engineer shall specify and ensure the provision of:

- (a) correct bolt size, grade, type, thread form;
- (b) installation procedure (eg, torques, tightening procedures);
- (c) retention devices or system to retain nuts, studs, unless deemed by the designer to be unnecessary for the design;
- (d) data plate permanently fixed to the vehicle close to the bolts and detailing information a, b and c above.

Bolt design shall be undertaken by the following means:

- (a) by the manufacturer of proprietary specialised components (eg, load cell manufacturer) by design calculation and/or testing to the loading provisions of this Code, where applicable;
otherwise
- (b) bolts subject to dynamic loads predominantly in the axial direction shall be designed to BS 7608:1993;
and
- (c) bolts subject predominantly to dynamic shear loads shall be designed to AS 3990:1993;

Where bolts have been fitted in holes with clearance on diameter of less than 0.1 mm, then, for the purposes of this Code, the joint needs to be designed to avoid slip in accordance with AS 3990-1993 Appendix F section F3 in the dynamic load case only. The Engineer shall establish the appropriate slip factor to use for the bolt torques specified. The bolts shall still be separately designed for the full static loads, but in this case limited slip is permissible.

- (d) non metric bolts, to a suitable recognised standard, for example, S.A.E., may be substituted for metric bolts referred to in AS 3990 and BS 7608 provided they meet the loadings imposed in terms of this Code.

8. Welding considerations

All welding shall comply with AS/NZS 1554.1 or for quenched and tempered steels AS/NZS 1554.4. The required weld categories (GP, SP or FP) shall be stated on the drawings.

9. Secondary attachment devices

Where an existing primary attachment does not meet the requirements of this Code it is permissible to fit a secondary independent bolster attachment system to ensure restraint of the bolster should the primary system fail. The secondary attachment device is permissible for bolsters manufactured and fitted to vehicles before the introduction of this Code.

The secondary system shall:

- (a) be capable of meeting the load and stress requirements of clauses 3.2, 4.2, 5.2 and clause 2.6 for static loadings only;

and

- (b) be used only to provide emergency restraint to the bolster(s) until the primary system is immediately and permanently repaired;

and

- (c) restraining the bolster in position under load, not exceeding 10 mm linear displacement in any direction, or ± 5 degrees angular displacement, from the normal unloaded bolster position.

Appendix

Sample forms of LTSA approved acceptable design certificates.

No 1

[Engineers or Company Letterhead – including name, physical address plus postal address, phone, fax etc]

Bolster Attachment Code: Certificate of Installation/Repair Compliance

Certificate No.
 Certificate Expiry *(Minimum three years, maximum ten years.)*
 Job/File No *(Engineer must record in a Bolster attachment code register.)*
 Vehicle Make Vehicle Model
 Vehicle Registration No. *(Not required for new entry vehicles.)*
 Vehicle Chassis/VIN No.
 Owner
 Maximum Payload of Logs Allowable on Vehicle
 Maximum Vehicle Mass Allowable When Carrying Logs
 Applicable Certificate of Design Compliance
 Applicable Certificate of Manufacture Compliance
 Installation Specification followed
 Bolster attachments do/do not *(delete one)* rely on secondary attachment devices.

| Bolster type and location | Bolster Serial No | Bolster attachment serial no | Load cell serial no | Drawing Number/ Numbers | Bolster attachment expiry date* | Maximum Log Load Permitted in Bolster (kg) |
|---------------------------|-------------------|------------------------------|---------------------|-------------------------|---------------------------------|--|
| | | | | | | |
| | | | | | | |
| | | | | | | |
| | | | | | | |
| | | | | | | |
| | | | | | | |

*Date of certification expiry for bolster attachment as a whole.

This is to certify that the bolster attachments identified above comply with the requirements of the Bolster Attachment Code. *(Bolster Attachment Code refers to the Log Transport Safety Committee, Bolster Attachment Code (Latest version).)*

The only standards and codes of practice used are those referenced in the Bolster Attachment Code.

Certificate No. Page 1 of 2 Signed

- 1.1 I have clearly established that all of the design required in accordance with the Bolster Attachment Code has been carried out.
- 1.2 I have sound reason to believe that I have fully understood all of the designers and manufacturers intentions and requirements.
- 1.3 The installation is in accordance with the Bolster Attachment Code, and as detailed in drawings and instructions.
- 1.4 I have inspected the complete bolster attachment installation/repair (*delete as applicable*) on the above vehicle. Visual inspection indicates that all work complies with the codes, standards, instructions and drawings.
- 1.5 All the bolster attachment designer's installation instructions and drawings are held in the above file.
- 1.6 All welding complies with statutory requirements, as referred to in the Land Transport Safety Authority publication, "Welding in the Transport Industry".
- 1.7 Bolster attachment components with a shorter life than bolster attachment as a whole are as the following table:

| Bolster attachment Serial Number | Components | Scheduled replacement Interval | Replacement Made by | Date Replacement made | Signature |
|----------------------------------|------------|--------------------------------|---------------------|-----------------------|-----------|
| | | | | | |
| | | | | | |
| | | | | | |
| | | | | | |
| | | | | | |

The Bolster serial number is issued by the bolster manufacturer.

The designer shall identify the components.

Designer to state component life. Installer to state replacement date.

Modifications are design changes, and require a new Certificate of Compliance.

Installation/Repair Company

Welder Name Welder Number

Signed..... Name..... Date: / /

Certifying Engineer, Category CB, Approval Number

Certificate No..... Page 2 of 2 Signed.....

[Engineers or Company Letterhead – including name, physical address plus postal address, phone, fax etc]

Bolster Attachment Code: Certificate of Manufacture Compliance

Certificate No.
 Certificate Expiry *(Minimum three years, maximum ten years.)*
 Job/File No. *(Engineer must record in a Bolster attachment code register.)*
 Vehicle Make Vehicle Model
 Vehicle Registration No. *(Not required for new entry vehicles.)*
 Vehicle Chassis/VIN No.
 Owner
 Maximum Payload of Logs Allowable on Vehicle
 Maximum Vehicle Mass Allowable When Carrying Logs
 Applicable Certificate of Design Compliance
 Design Specification followed for manufacture.....
 Specification to be followed for Installation.....
 Extent of Components covered by this Certificate
 Bolster attachments do/do not (delete one) rely on secondary attachment devices.

| Bolster type and location | Bolster Serial No. | Bolster attachment serial no. | Load cell serial no. | Drawing number/ numbers | Bolster attachment expiry date* | Maximum Log Load Permitted in Bolster (kg) |
|---------------------------|--------------------|-------------------------------|----------------------|-------------------------|---------------------------------|--|
| | | | | | | |
| | | | | | | |
| | | | | | | |
| | | | | | | |
| | | | | | | |

*Date of certification expiry for bolster attachment as a whole.

This is to certify that the bolster attachments identified above comply with the requirements of the Bolster Attachment Code.*(Bolster Attachment Code refers to the Log Transport Safety Committee, Bolster Attachment Code (Latest version).)*

The only standards and codes of practice used are those referenced in the Bolster Attachment Code.

Certificate No..... Page 1 of 2

Signed.....

- 1.1 These attachments will only perform to the requirement of the Bolster Attachment Code when they have been installed to the approved installation drawings and when the installation has been verified and endorsed by an approved Engineer.
- 1.2 I have clearly established that all of the design required for manufacture in accordance with the Bolster Attachment Code has been carried out.
- 1.3 I have sound reason to believe that I have fully understood all of the designers intentions and requirements.
- 1.4 The manufacture has been carried out in accordance with the Bolster Attachment Code, and as detailed in drawings and instructions.
- 1.5 I have inspected the bolster attachment components. Visual inspection indicates that manufacture complies with the codes and standards listed and with drawings.
- 1.6 All drawings (general arrangement, components, & systems), component specifications, and fabricator instructions as applicable are held in the above file.
- 1.7 Welding complies with statutory requirements, as referred to in the Land Transport Safety Authority publication, "Welding in the Transport Industry". (*Obtainable from the Land Transport Safety Authority.*)
- 1.8 Bolster attachment components with a shorter life than bolster attachment as a whole are as the following table:

| Bolster Attachment Serial Number | Components | Scheduled replacement Interval |
|----------------------------------|------------|--------------------------------|
| | | |
| | | |
| | | |
| | | |
| | | |

The Bolster serial number is issued by the bolster manufacturer.

Manufacturer

Welder Name Welder Number

SignedName Date: / /

Certifying Engineer, Category CB, Approval Number

Certificate No..... Page 2 of 2 Signed.....

[Engineers or Company Letterhead – including name, physical address plus postal address, phone, fax etc]

Bolster Attachment Code: Certificate of Design Compliance

- Certificate No.
- Certificate Expiry *(Minimum three years, maximum ten years.)*
- Job/File No. *(Engineer must record in a Bolster attachment code register.)*
- Bolster Attachment Type
- Drawing Numbers.....
- Manufacture Specification
- Installation Specification
- Extent of components covered by this certificate
- Extent of design covered by this certificate.....
- Maximum Log Load Permitted in Bolster (kg)
- Maximum Bolster Bed Height Covered by Design
- Bolster Attachment Design Life.....

This is to certify that the bolster attachments identified above comply with the requirements of the Bolster Attachment Code.*(Bolster Attachment Code refers to the Log Transport Safety Committee, Bolster Attachment Code (Latest version).)*

The only standards and codes of practice used are those referenced in the Bolster Attachment Code.

- 1.1 The bolster attachments detailed above have been designed in accordance with the Bolster Attachment Code.
- 1.2 These attachments will only perform to the requirement of the Bolster Attachment Code when they have been manufactured and installed to the approved installation drawings and when the installation has been verified and endorsed by an approved Engineer.
- 1.3 All design analysis, calculations, drawings (general arrangement, components, & systems), component specifications, and fabricator instructions are held in the above file.
- 1.4 All installation instructions and drawings are held in the above file.

Certificate No..... Page 1 of 2 Signed.....

- 1.5 Bolster attachment components with a shorter life than bolster attachment as a whole are as the following table:

| Bolster Attachment Type | Components | Scheduled replacement Interval |
|-------------------------|------------|--------------------------------|
| | | |
| | | |
| | | |
| | | |
| | | |
| | | |

Signed..... Name..... Date: / /

Certifying Engineer, Category CB, Approval Number

Certificate No..... Signed.....

[Engineers or Company Letterhead – including name, physical address plus postal address, phone, fax etc]

Bolster Attachment Code: Certificate of Compliance

Certificate No.
 Certificate Expiry *(Minimum three years, maximum ten years.)*
 Job/File No. *(Engineer must record in a Bolster attachment code register.)*
 Vehicle Make Vehicle Model
 Vehicle Registration No. *(Not required for new entry vehicles.)*
 Vehicle Chassis/VIN No.
 Owner
 Maximum Payload of Logs Allowable on Vehicle
 Maximum Vehicle Mass Allowable When Carrying Logs
 Bolster attachments do/do not (delete one) rely on secondary attachment devices.

| Bolster type and location | Bolster Serial No | Bolster attachment serial no. | Load cell serial no. | Drawing Number/ Numbers | Bolster attachment expiry date* | Maximum Log Load Permitted in Bolster (kg) |
|---------------------------|-------------------|-------------------------------|----------------------|-------------------------|---------------------------------|--|
| | | | | | | |
| | | | | | | |
| | | | | | | |
| | | | | | | |
| | | | | | | |
| | | | | | | |

*Date of certification expiry for bolster attachment as a whole.

This is to certify that the bolster attachments identified above comply with the requirements of the Bolster Attachment Code.*(Bolster Attachment Code refers to the Log Transport Safety Committee, Bolster Attachment Code (Latest version).)*

The only standards and codes of practice used are those referenced in the Bolster Attachment Code.

This certificate is only valid when signed in all three locations; section 1, 2 and 3.

**1 Bolster Attachment Design Certification
 (Including Any Secondary Attachment Devices)**

1.1 The bolster attachments detailed above have been designed in accordance with the Bolster Attachment Code.

Certificate No..... Page 1 of 3

Signed.....

1.2 These attachments will only perform to the requirement of the Bolster Attachment Code when they have been manufactured and installed to the approved installation drawings and when the installation has been verified and endorsed by an approved Engineer.

1.3 All design analysis, calculations, drawings (general arrangement, components, & systems), component specifications, and fabricator instructions are held in the above file.

1.4 All installation instructions and drawings are held in the above file.

Signed..... Name..... Date: / /

Certifying Engineer, Category CB, Approval Number

2 Manufacture Certification

2.1 I have clearly established that all of the design required for manufacture in accordance with the Bolster Attachment Code has been carried out.

2.2 I have sound reason to believe that I have fully understood all of the designers intentions and requirements.

2.3 The manufacture has been carried out in accordance with the Bolster Attachment Code, and as detailed in drawings and instructions.

2.4 I have inspected the bolster attachment components. Visual inspection indicates that manufacture complies with the codes and standards listed and with drawings.

2.5 All drawings (general arrangement, components, & systems), component specifications, and fabricator instructions as applicable are held in the above file.

2.6 Welding complies with statutory requirements, as referred to in the Land Transport Safety Authority publication, "Welding in the Transport Industry". (*Obtainable from the Land Transport Safety Authority.*)

Manufacturer

Welder Name Welder Number

Signed..... Name..... Date: / /

Certifying Engineer, Category CB, Approval Number

Certificate No..... Page 2 of 3

Signed.....

3 Installation/ Repair Certification

- 3.1 I have clearly established that all of the design required in accordance with the Bolster Attachment Code has been carried out.
- 3.2 I have sound reason to believe that I have fully understood all of the designers and manufacturers intentions and requirements.
- 3.3 The installation is in accordance with the Bolster Attachment Code, and as detailed in drawings and instructions.
- 3.4 I have inspected the complete bolster attachment installation/repair (delete as applicable) on the above vehicle. Visual inspection indicates that all work complies with the codes, standards, instructions and drawings.
- 3.5 All the bolster attachment designer’s installation instructions and drawings are held in the above file.
- 3.6 All welding complies with statutory requirements, as referred to in the Land Transport Safety Authority publication, “Welding in the Transport Industry”.

Installation/Repair Company

Welder Name Welder Number

Signed Name Date: / /

Certifying Engineer, Category CB, Approval Number

4 Special Conditions

4.1 Bolster attachment components with a shorter life than bolster attachment as a whole.

| Bolster Attachment Serial No. | Components | Scheduled replacement Interval | Replacement Made by | Date Replacement Made | Signature |
|-------------------------------|------------|--------------------------------|---------------------|-----------------------|-----------|
| | | | | | |
| | | | | | |
| | | | | | |
| | | | | | |

The Bolster serial number is issued by the bolster manufacturer.

The designer shall identify the components.

Designer to state component life. Installer to state replacement date.

Modifications are design changes, and require a new Certificate of Compliance.

4.2

4.3

Certificate No..... Page 3 of 3 Signed.....

[Engineers or Company Letterhead – including name, physical address plus postal address, phone, fax etc]

Bolster Attachment Code: Certificate of Manufacture Compliance

Certificate No. File No. *(manufacturer)/.....(certifier)

This is to certify that I have inspected the bolster attachment components manufactured byas identified below. Visual inspection indicates that manufacture has been carried out in strict accordance with the design requirements of Certificate of Component Design Compliance numberwhich covers bolster attachment components built to(drawing issuer) drawing number

Job number..... Date of manufacture.....

Description of component.....

Component Serial Numbers*

Compliance Conditions and Explanatory Notes

- *1. The manufacturer’s certifying engineer must record the above file and serial numbers in a Bolster attachment code register.
2. Bolster Attachment Code refers to the LTSA-approved Log Transport Safety Committee Bolster Attachment Code.
3. These attachment components will only comply with the requirement of the Bolster attachment Code when they have been installed to the approved installation drawings as part of a complete bolster-to-chassis attachment system and when the installation has been verified and endorsed by an approved Engineer.
4. I have established that all of the requirements specified in the design documents have been carried out and that the designer’s drawings and requirements have been clearly understood by the manufacturer and the manufacturer’s certifying engineer.
5. All drawings (general arrangement, components, & systems), component specifications, fabricator instructions, records of manufacture & inspection as applicable are held in the above file(s).
6. Welding complies with statutory requirements, as referred to in the Land Transport Safety Authority publication, “Welding in

the Transport Industry". (Obtainable from the Land Transport Safety Authority.)

Welder Names and NZS4711 numbers.....

.....

I have fully understood and carried out all of the above requirements.

Signed..... Name..... Date: / /

Certifying Engineer, Category CB, Approval Number

Certificate No..... Signed.....

Design certifier/Manufacturer copy No 6

[Engineer’s or Company Letterhead – including name, physical address plus postal address, phone, fax etc]

Bolster Attachment Code: Certificate of Design Compliance

Certificate No.

This certificate covers the design of the rigid / resilient / sliding / torsionally independent (*delete not applicable*) logging bolster attachment components as detailed on Drawing Number(s) for manufacture by

All Manufacturing, Installation and Operational instructions relevant to the above component design are specified in the above drawing(s).

All design analysis, calculations, drawings (general arrangement, components, & systems), component specifications, and fabricator instructions are held in Job/File No.....at (Engineer must record in a Bolster attachment code register.)

Bolster attachment group description.....

Extent of components covered by this certificate

Extent of design covered by this certificate.....

Bolster base dimensions approved for use with this design:

Width height (Refer to the above drawing for further details of bolster compatibility requirements.)

This design is approved for use in conjunction with loadcell make & model number (if applicable):.....

Maximum Certificate Life of a bolster attachment containing any components built to this design isyears

Design Life of a bolster attachment containing any components built to this design isyears (Minimum three years, maximum ten years.)

Maximum Log Load Permitted in Bolsterkg (*note that this may be further limited by the nature of the total bolster attachment system in which the component design is used – refer to installation certificate*)

This certificate is valid for use by the above designated manufacturer until or until any revision of the current Bolster Attachment Code dated (whichever is sooner), after which time no new components may be manufactured under this certificate until the design has been reassessed by a CB-approved engineer and re-certified.

I,, hereby certify (not to be construed as a guarantee) that the bolster attachment component design as identified above complies with the requirements of the Bolster Attachment Code and all standards and codes of practice referred to therein, subject to the following conditions.

Note

1. Bolster Attachment Code refers to the LTSA-approved Log Transport Safety Committee Bolster Attachment Code.
2. This certificate covers the **design only** of a **component or components** of a total bolster attachment system. The attachment component(s) has/have been designed to be manufactured and installed as part of a complete bolster attachment system which will comply with the Bolster Attachment Code only when this and all other components of the system have been separately certified as being designed, manufactured and installed in accordance with the Code by an approved CB Engineer.
3. This certificate is therefore invalid unless accompanied by (a) a certificate of manufacture for any component built to the above drawing and (b) a certificate of compliance (with original signature of installation certifier) covering the installation of that component on a vehicle, including any design and manufacture work involved in the installation.
4. Any change or revision to the above drawing or its sub-drawings or specifications invalidates this certificate for new construction.
5. Any change to the above drawing or its sub-drawings or specifications must be approved by a CB-rated certifying engineer and a new design certificate issued.
6. The following table specifies parts belonging to the above bolster attachment component(s) which have a shorter design life than stated above: (also included are any short-life items which interface to the above certified components e.g. bolts)

| Part | Scheduled replacement interval | Replacement instructions |
|------|--------------------------------|--------------------------|
| | | |
| | | |
| | | |
| | | |
| | | |

- 7. Acceptance of this certificate by the manufacturer and/or manufacturing certifier implies an obligation to inform the original design certifying engineer of any manufacturing problems, in-service defects or failures which may arise.
- 8. The above drawing number(s) are issued by
- 9. An original of this design certificate must be held by the manufacturer and will be invalid for new manufacture of components to the above design without the design certifier's and manufacturer's original signatures below.

.....

Signed Print full Name Date:../...../.....

Certifying Engineer, Category CB, Approval Number

I, of

(*manufacturer*) hereby accept the terms and conditions of the above certificate.

Signed..... Date:..... ./...../.....

Certificate No..... Signed.....

Design Certifier/Manufacturing certifier/Installation certifier/Owner/ VTNZ copy No 7

[Engineers or Company Letterhead – including name, physical address plus postal address, phone, fax etc]

Bolster Attachment Code: Certificate of Compliance

Certificate No.
 Certificate Expiry *Minimum is three years from date of issue, maximum ten years. (Date of certification expiry for vehicle bolster attachment installation as a whole, excluding any short-life components listed in Table C)*

Certifier’s Job/File No. (Engineer must record in a Bolster attachment code register.)

Vehicle Make & Model

Registration NoChassis/VIN No.

Owner

Maximum Payload of Logs Allowable on Vehicle (kg)

Maximum Vehicle Mass Allowable When Carrying Logs (kg)

Table A: Vehicle Bolster attachment systems

| Bolster type and location | Bolster Serial No. | Design relies on Secondary Attachment device(s) (yes/no) | Drawing Number/Numbers specifying manufacturing, installation and operating instructions for total bolster to chassis attachment. | Log Payload Rating per bolster (kg) |
|---------------------------|--------------------|--|---|-------------------------------------|
| | | | | |
| | | | | |
| | | | | |
| | | | | |
| | | | | |
| | | | | |

In the event of replacement of individual bolsters attachments, individual lines may be crossed out in the above table but a new compliance certificate must be issued for the replacement bolster attachment.

Notes:.....
.....

This is to certify that the bolster attachments identified above comply with the requirements of the Bolster Attachment Code and all standards and codes of practice referred to therein. (Bolster Attachment Code refers to the LTSA-approved Log Transport Safety Committee Bolster Attachment Code, current version.)

This certificate is only valid when signed in all three sections 1, 2 and 3.

1 Bolster Attachment Design Certification (Including any Secondary Attachment Devices)

1.1 I have designed the bolster attachment systems detailed in Table A above, (except for those pre-certified components or subassemblies covered in Table B), in accordance with the Bolster Attachment Code.

1.2 These attachments will only comply with the requirements of the Bolster Attachment Code when they have been manufactured and installed to the approved installation drawings

and when the installation has been verified and endorsed by an CB-approved Engineer.

- 1.3 All design analysis, calculations, drawings (general arrangement, components, & systems), component specifications, and fabricator instructions are held in the above file.
- 1.4 All installation instructions and drawings are held in the above file.
- 1.5 Separate certificates of design are attached covering the design of the following components or subassemblies used in above bolster attachments:

Table B: Pre-Certified Components or subassemblies

| Bolster serial number | Bolster attachment component drawing number | Bolster attachment component description and extent of design covered | Manufacturer of pre-certified components | Component serial numbers |
|-----------------------|---|---|--|--------------------------|
| | | | | |
| | | | | |
| | | | | |
| | | | | |
| | | | | |
| | | | | |

- 1.6 All the component or subassembly designer's recommendations, instructions and drawings for the interface of any Table B components with the bolster attachment systems listed in Table A have been complied with insofar as the design of the bolster attachment as a whole is concerned. All such recommendations, instructions and drawings are held on the above file.
- 1.7 Modifications are design changes, and require a new Certificate of Compliance

Signed Name Date:/...../.....

Certifying Engineer, Category CB, Approval Number

2 **Manufacture Certification**

Manufacturer Manufacturer's job number
.....

Welder Name(s) and NZS4711 number(s)
.....

- 2.1 I have clearly established that all of the design required for manufacture in accordance with the Bolster Attachment Code has been carried out.
- 2.2 I have sound reason to believe that I have fully understood all of the designers intentions and requirements.
- 2.3 The manufacture has been carried out in accordance with the Bolster Attachment Code, and as detailed in the design certifier’s drawings and instructions.
- 2.4 I have inspected the bolster attachment components. Visual inspection indicates that manufacture complies with the drawings listed in Table A.
- 2.5 All manufacturing drawings (general arrangement, components, & systems), component specifications, fabricator instructions, inspection records & photographs as applicable are held in file *(Engineer must record in a Bolster attachment code register.)*
- 2.6 Welding complies with statutory requirements, as referred to in the Land Transport Safety Authority publication, “Welding in the Transport Industry”.*(Obtainable from the Land Transport Safety Authority.)*
- 2.7 Separate certificates of manufacture are attached covering any pre-certified subassemblies or components identified in Table B which have been used in the above bolster attachments.

Signed Name Date: /..... /.....

Manufacturer Certifying Engineer, Category CB, Approval Number

3 Installation/ Repair Certification

Installation/Repair Company

Installation Company File No Installation company job no.....

Welder Name(s) and NZS4711 Number(s)

.....

- 3.1 I have clearly established that all of the design required in accordance with the Bolster Attachment Code has been carried out.
- 3.2 I have sound reason to believe that I have fully understood all of the designers and manufacturers intentions and requirements.

- 3.3 The installation is in accordance with the Bolster Attachment Code, and as detailed in the installation drawings and instructions specified in Table A.
- 3.4 I have inspected the complete bolster attachment installation/repair (delete as applicable) on the above vehicle. Visual inspection indicates that all work complies with the codes, standards, instructions and drawings.
- 3.5 All the bolster attachment designer’s installation instructions and drawings, and installation inspection records are held in Installation Certifier’s File no.....(*Engineer must record in a Bolster attachment code register.*)
- 3.6 All welding complies with statutory requirements, as referred to in the Land Transport Safety Authority publication, “Welding in the Transport Industry”.

Table C: Bolster attachment components with a shorter life than bolster attachment as a whole

| Bolster Serial Number | Bolster attachment components | Scheduled replacement date | Replacement carried out by | Date replacement carried out | Signature |
|-----------------------|-------------------------------|----------------------------|----------------------------|------------------------------|-----------|
| | | | | | |
| | | | | | |
| | | | | | |
| | | | | | |
| | | | | | |
| | | | | | |

** The Bolster serial number is issued by the bolster manufacturer.
 ** The installation certifying engineer shall identify bolster, components, replacement dates. Continue on separate sheet if necessary.
 *** Company carrying out replacement shall obtain and follow all replacement instructions from the installation company.*

Notes

.....

Signed Name Date:/...../.....

Installation Certifying Engineer, Category CB, Approval Number

Certificate No..... Signed.....

Schedule 3

NZ Truck-Trailer Manufacturers' Federation Recommended Practice

Heavy Motor Vehicle Towing Connections Drawbar Trailers

Introduction

This code was initiated as a result of the District Coroner's findings in a double fatality traffic accident in the Bay of Plenty in 1979. Also at this time equipment failures were occurring in the Waikato region.

The N.Z. Truck Trailer Manufacturers' Federation (NZTTMF) called an urgent meeting of interested parties at Rotorua on Wednesday, 14th November 1979. Attending this meeting were representatives from the NZTTMF, associated members of that Federation, Government representatives from the Ministry of Transport, Accident Compensation Commission and N.Z. Forest Service, members of the Institute of Road Transport Engineers (IRTENZ), equipment suppliers to the industry, engineering consultants, and transport operators. As a result of this meeting a committee was formed comprising the following:

N.T. Peterken Chairman representing NZTTMF
A.J. Wilkinson Secretary representing IRTENZ
W.G. Cassidy representing N.Z. Institute of Engineering (now IPENZ)
F.R. Bartram representing IRTENZ
R.B. Clotworthy representing the Road Transport Association
W.R. Law representing NZTTMF

The committee used as a basis a draft code initiated by the Ministry of Transport as well as calculations by members of the committee and extensive overseas literature.

By early 1981 a Code of Practice was formulated and went into use throughout the country. The code was only enforced consistently in the Waikato and Bay of Plenty regions but has resulted in a significant improvement in manufacture and maintenance of couplings. During this period the industry checked a number of existing drawbars and drawbeams for any fault. The committee also requested the assistance of the DSIR to verify and refine the loadings and design factors used in the Code. This was achieved through an extensive test programme on actual vehicles in service. All of this has culminated in the following Code of Practice which has been made possible by the combined efforts of the NZTTMF, IRTENZ, the Road Transport Industry and the DSIR. This work is an excellent example of co-operative effort and dedication to overcome a serious problem being experienced in our industry. The total cost to date has been borne by the Industry and the DSIR.

Acknowledgements

I would like to take this opportunity to thank all those that were involved in the preparation and formation of this Code and particularly the following: members of

the Committee, A.J. Wilkinson who acted as secretary, W.G. Cassidy, F.R. Bartram, R.B. Clotworthy and W.R. Law and also those members of the DSIR who worked endlessly on the testing and design criteria. These members were R.F. Mackay, P.H. Baas, D.M. White, N.A. Miller, W.J. Handey, G.T. Bastin, A.D. Lush, C.R. Moodie and K.J. Riddell.

Testing would have been impossible without the assistance of members of the Road Transport Association and ancillary groups who loaned vehicles and equipment and we pay particular thanks to the Freightways Express Limited, Transport Container Pool Limited, Chep Handling Limited, N.Z. Express Limited, Halls Meat Transport Limited, Carr & Haslam Limited, N.Z. Forest Products Limited and Winstones Limited. I must also thank members of IRTE for their input and individual practical and technical knowledge, members of the Truck-Trailer Manufacturers' Federation for their input and particularly Domett Fruehauf Trailers Limited and Steel Bros. N.Z. Ltd for the supply of drawbar and drawbeam equipment for testing. The equipment suppliers also played their part providing relevant overseas literature. Particular thanks to Motor Specialties Limited and Transport Specialities Limited for information from VBG and Ringfeder couplings.

N.T. Peterken

Committee Chairman

Recommendations

The Committee recommends that the Ministry of Transport:

- (1) adopts this Code of Practice in its entirety and
- (2) uniformly enforces it throughout the country.

The Committee also recommends that the formation of this Code be used as a model for the development of future design criteria in other areas of transport safety such as:

- Turntables
- Brakes
- Kingpins
- Pole trailers
- Tow coupling pins
- Vehicle suspensions

Section 1 Scope

- 1.1 This Recommended Practice is intended to clarify design, maintenance and inspection considerations necessary to assure that couplings and associated mechanisms are of 'adequate strength' to comply with the requirements of *Regulations 83(b)* of the *Traffic Regulations 1976*.

- 1.2 Although primarily covering applications incorporating pin or hook type couplings, the practice should also apply to ball type couplings as appropriate. Requirements include both fixed, and pivoting drawbars.
- 1.3 This recommended practice shall relate to all components as under:
- (a) Drawbeam
 - (b) Drawbar
 - (c) Couplings
 - (d) Methods of attachment
 - (1) To truck chassis
 - (2) To trailer chassis.
- 1.4 The designer must ensure that the components being designed or specified are compatible with the trailer and that the trailer is suitable for its intended use.

Section 2 Interpretations

- 2.1 **COUPLING:** that part of the connecting mechanism by which the connection is actually made but does not include any structural member or extension of the towing or towed vehicle frame.
- 2.2 **COUPLING MOUNTING OR DRAWBEAM:** member or members to which the towing vehicle portion of the coupling is attached.
- 2.3 **'D' VALUE:** An expression of loading capacity of a coupling, or towing eye derived from the Class I mass of the towing vehicle(s) and the Class I mass of the trailer(s), or the respective Manufacturer's G.V.W.'s whichever is the lower in each case.

The 'D' value shall be derived from the following formula.

$$D = \frac{G_K \times G_A}{G_K + G_A}$$

D = value in tonnes

G_K = total mass of all vehicles in front of the coupling in tonnes

G_A = total mass of all vehicles behind the towing coupling in tonnes.

- 2.4 DESIGN CERTIFICATE: The Design Certificate shall be a statement in a form approved by the Ministry of Transport, stating standards to which the drawbar or components have been designed, and incorporating the name of the person, Company, or Agency carrying out the certification, and the serial number of the component concerned.
- The Design Certificate shall cover the following as applicable:
- (1) Original design
 - (2) Manufacture
 - (3) Subsequent manufacture or repair.
- The Design Certificate shall be signed by a ‘Mechanical Engineer’ (refer to 2.8) certifying the original design, manufacture or repair. Where approval is given by the ‘Mechanical Engineer’ in writing, then subsequent manufacture or repair Certificates can be signed by a Registered Engineer’s Associate or a person approved by the original Certifying Mechanical Engineer stating that the manufacture and/or repair complies with the original design.
- 2.5.1 DESIGN: The design shall take into account dynamic loadings (fatigue).
- 2.5.2 DESIGN STRESS: Where ‘Design’ is referred to design stresses are to be specified as in Appendix 1.
- 2.6 DRAWBAR: The member or members, including the towing eye, to which the trailer portion of the vehicle is attached.
- 2.7 DRAWBAR ATTACHMENT: The attachment between the drawbar and the trailer. This may be hinged or rigid as appropriate.
- 2.8 ‘MECHANICAL ENGINEER’: A Registered Mechanical Engineer registered under the *Engineer’s Registration Act 1924* and amendments.
- 2.9 SAFETY CHAIN: A safety chain is the chain (or steel wire rope) from the front of a full trailer or converter dolly to rear of the towing vehicle for the purpose of retaining the connection between towing and towed vehicles and of controlling the direction of travel of the towed vehicle in the event of failure of the drawbar or the connection on the rear of the towing vehicle.
- 2.10 TOWING EYE: That portion of the drawbar which engages the coupling, and which may be welded or bolted into the drawbar.

Section 3 Coupling mounting or drawbeam

- 3.1 **LOADING:** The coupling mounting or drawbeam shall be designed for a towing capacity and other considerations as specified in Section 6.1.2 as appropriate.
- 3.2 **ATTACHMENTS:** Shall be adequately secured in such a manner that the forces in 3.1 are transmitted to the vehicle frame or structural members without incurring loss of attachment or distortion or failure which would affect the safe towing of the trailer(s).
- 3.3 **LOCATION:** To be positioned as close as practicable behind the rear wheels of the vehicle and on the longitudinal axis.
- 3.4 **DESIGN:** Manufacture and installation to be certified in accordance with the requirements of 2.4. The drawbeam is to be identified as in 6.1.5.1.
- 3.5 **REPAIR:** Refer to 6.2. Deformed or fractured coupling mounting components shall not be repaired, and must be replaced (normal maintenance excepted).
- 3.6 **WELDING:** All welding shall comply with 6.1.4.

Section 4 Couplings

- 4.1 **ALL COUPLINGS:** shall comply with DIN 74051 (40 mm pin) or 74052 (50 mm pin) ISO 1102; SAE J849b AS2212; together with BSAU24, 25 and 27 or equivalent standards and installed in accordance with the Manufacturer's specifications.
- If no Manufacturer's specifications for fixing bolts are provided use I.S.O. high tensile bolts and nuts grade 8.8 torqued to produce a stress of 65% of yield.
- 4.1.1.1 **CAPACITY:** The capacity of coupling shall be at least equal to the 'D' value rating for the combination in use.
- 4.1.1.2 The maximum gross towed mass should be specified on loading certificates of vehicles to which couplings are fitted. The gross towed mass is derived from the capacity of the coupling actually fitted, or vehicle manufacturers gross train mass whichever is the lesser.
- Trailers may not be towed by vehicles without loading certificates so endorsed.
- 4.1.1.3 **VERTICAL LOAD CAPACITY:** Couplings for use with fixed drawbar trailers are to have a vertical load capacity as

determined in 6.1.2.4, or be of hook, pintle or ball type with a rating as calculated in 4.1.1.2 and complying with approved standards, or the Manufacturer's coupling rating.

4.1.2 ARTICULATION REQUIREMENTS

4.1.2.1 **PIN TYPE COUPLINGS:** The towing eye shall be fixed in the drawbar and angular movement provided within the coupling. Clearance between a parallel coupling pin and the drawbar eye is not acceptable towards meeting the specified articulation angles. This requirement shall not apply to trailers where the drawbar is used only for steering the trailer (pole trailer).

4.1.2.2 Hook or pintle type coupling. Towing eye rotation is acceptable towards meeting the articulation angle requirements.

4.1.2.3 Angular deflection

Horizontal plane: at least $\pm 75^\circ$ (from the straight aft position).

Vertical plane: at least $\pm 20^\circ$ from the horizontal.

Roll angles: at least $\pm 25^\circ$ around the longitudinal axis.

The planes and axis to be considered as acting through the effective thrust point on the coupling pin or hook.

4.1.3 **COUPLING LOCATION:** The coupling shall be as close as practicable to the rear axle, on the centre line of the vehicle and consistent with maintaining drawbar articulation angles specified in 4.1.2.3.

4.1.4 **SAFETY LOCK:** A safety coupling device shall be provided to prevent accidental removal of the coupling pin.

4.2 MAINTENANCE AND INSPECTION

4.2.1 Control heads and safety locking devices must operate smoothly and effectively, and fastenings shall be secure.

4.2.2 **COUPLING MOUTH:** Shall only be repaired in accordance with manufacturer's instruction.

4.2.3 **COUPLING PINS AND TOWING HOOKS:** Shall not be repaired or welded. If damaged, deformed, fractured or worn at any one point exceeding 5% of the original dimensions or the manufacturer's wear tolerance, the components must be replaced.

Section 5 Towing eye

- 5.1 The capacity of the towing eye shall be as defined in DIN 74053 (50 mm pin): 74054 (40 mm pin) or as specified by the manufacturer.
- 5.2 The pin and towing eye diameter in pin type couplings is to be 40 mm or 50 mm diameter only. Provision for replacement towing eye bushes may be included but the means of retaining shall not allow any welding process (towing eyes of circular section are not acceptable for use with pin type couplings).
- 5.3 Instructions by the towing eye manufacturer in regard to welding procedure, heat treatment, electrodes, etc are to be followed.
- 5.4 Towing eyes shall not be repaired and if damaged, deformed, fractured or worn at any one point beyond 5% of the original dimension, or the manufacturer's wear tolerance, the eye shall be replaced.
- 5.5 Towing eye bushes. Shall be replaced only in accordance with manufacturer's instructions, and shall not be retained by welding.
- 5.6 The welding of the side arms to the towing eye shank is to be on the parallel shank only, or as specified by the towing eye manufacturer.
- 5.7 Support is to be included in the drawbar design to prevent ground contact of the drawbar eye.

Section 6 Drawbar

- 6.1 DESIGN AND MANUFACTURE
- 6.1.1 Refer to 2.5 for requirements of the Designer.
- 6.1.2 LOADING
- 6.1.2.1
- (a) Drawbars and methods of attachment to the towing eye and the trailer frame or axle assembly to withstand a longitudinal load in direct **tension** and **compression** of 125% of the maximum gross towed mass, without permanent deformation (refer to Appendix I), and
 - (b) Drawbars and method of attachment to the towing eye and the trailer frame or axle assembly to withstand a dynamic loading (fully reversed fatigue loading) of \pm seventy-five

percent (75%) of the gross towed mass, for the trailer under consideration.

- 6.1.2.2 Drawbars for trailers with turntable locks to withstand a sidethrust of 25% of the maximum gross towed mass applied at 90° to the longitudinal axis of the vehicle at the towing eye (without permanent deformation).
- 6.1.2.3 Drawbars for trailers without turntable locks to withstand a side thrust as defined in Table 5 of SMS 2333 (see Appendix 2).
- 6.1.2.4 Drawbars on trailers which transfer any portion of the trailer weight or braking force vertically to the coupling shall withstand a vertical thrust of 125% of the force applied by static load at the towing eye, plus brake torque and weight transfer which will result from a 1 g deceleration.
- 6.1.2.5 Eccentricities due to the layout, which may cause bending in members or their connections, are to be considered in the analysis of stresses; for example, the connection of the drawbar to the dolly, or where all members of the drawbar do not lie in the same plane.
- 6.1.2.6 **MATERIALS OF CONSTRUCTION:** The materials of construction shall be specified and the required mechanical properties detailed. Where alternative materials are used to those specified in Appendix I an equivalent level of safety shall be provided.
- 6.1.2.7 **BRITTLE FRACTURE:** The possibility of brittle fracture must be considered in the design.
- 6.1.2.8 **BOLTED CONNECTIONS:** All bolted connections shall comply with the requirements of AS 1250.
- 6.1.2.9 **DESIGN REQUIREMENTS OVERSEAS MANUFACTURE:** The above Design Requirements need not apply to components complying to DIN; SMS; AS Standards as applicable, but the attachments thereof are to comply with this Code. Clauses 2.4 and 6.1.5 must be complied with.
- 6.1.2.10 Pole type trailers are a special case, each to be considered on its merits.
- 6.1.3 **GENERAL CONSIDERATIONS - drawbar**
 - 6.1.3.1 The drawbar length should be the minimum practicable consistent with the operation, and preferably symmetrical in side elevation.

- 6.1.3.2 The drawbar should be level. Otherwise the slope should not exceed ± 1 in 10, when vehicles are in the laden condition.
- 6.1.3.3 The section change between the towing eye shank and structural members is to be as gradual as practicable.
- 6.1.3.4 Bends in structural members are to be as few as practicable and shall be reinforced.
- 6.1.3.5 The towing eye shank is to be fixed in the drawbar to prevent rotation, where used with rotating type couplings.
- 6.1.3.6 Support is to be incorporated in the drawbar to prevent ground contact of the towing eye.
- 6.1.3.7 The assembly should avoid sections capable of accumulating and retaining dirt, moisture or material likely to cause corrosion.
- 6.1.4 WELDING CONSIDERATIONS
- 6.1.4.1 All welding shall comply with NZSS 4701 (minimum Class A, preferably Class S), and operators with NZS 4711 in the appropriate positions.
- 6.1.4.2 Welding of side arms to the towing eye shank shall be on the parallel shank only.
- 6.1.4.3 All welds made on the towing eye, including tack welds and welding of cover plates etc. shall be carried out according to the manufacturer's recommendations. If no specific recommendations are given then the procedure given in 6.1.4.4 shall be used.
- 6.1.4.4 Where no specific recommendations for welding of the towing eye are given then the following weld procedure shall be used. Preheat to 250°C. Hydrogen controlled electrodes, dried according to the manufacturers recommendations, or a hydrogen controlled welding process shall be used to make all welds, including tack welds and welds on cover plates etc. After welding, the towing eye shall be protected by suitable means so as to ensure slow cooling from the welding temperatures.
- If welding on the towing eye is stopped for any length of time the component shall be raised to the preheat temperature before welding is recommenced.
- 6.1.4.5 All welds shall be visible for inspection purposes. Inspection of welds on the towing eye should preferably be carried out by ultrasonic methods in order to detect any heat affected zone cracking.
- 6.1.5 IDENTIFICATION

- 6.1.5.1 Every drawbar shall be checked after manufacture and certified as complying with the design specifications by indelible labelling or marking to clearly identify the person, company or agency carrying out the certification, the serial number, and the maximum towed mass rating.
- 6.1.5.2 The identification detail is to be located at the hinge end of the drawbar on the left-hand side.
- 6.2 REPAIR AND MAINTENANCE
- 6.2.1 Repairs or modifications are to be carried out by the person, Company, or Agency responsible for the original design and certification. Where this is impracticable, the repairs or modifications shall be carried out by a person filling the requirements of paragraph 2.4.
- 6.2.2 Deformed, worn or fractured drawbar components shall not be repaired and must be replaced.
- 6.2.3 Towing eye bushes must be fitted in accordance with the manufacturer's instructions and shall not be retained by welding.
- 6.2.4 All welding shall comply with Section 6.1.4.

Section 7 Drawbar attachment

- 7.1 DESIGN AND MANUFACTURE - INSTALLATION
- 7.1.1 Refer to 2.4 for the requirements of the Designer.
- 7.1.2 **LOADING:** The drawbar attachment shall be designed for a towing capacity and other considerations as specified in Section 6.1.2 as appropriate.
- 7.2 **ARTICULATION:** The drawbar attachment shall have articulation compatible with the requirements of 4.1.2.3.
- 7.3.1 **REPAIR AND MAINTENANCE:** Repairs or modifications are to be carried out by the person, Company or Agency responsible for the original design and certification. Where this is impractical, the repairs or modifications shall be carried out by a person, Company or Agency who fulfills the requirements of clause 2.4.
- 7.3.2 Deformed, worn or fractured drawbar attachment components shall not be repaired and must be replaced.
- 7.3.3 All welding shall comply with Section 6.1.4.

Section 8 Safety chain for full trailer or converter dollies

- 8.1 If the application requires safety chains or steel wire ropes to be fitted between the towing and towed vehicles, then the requirements of SAE J697a 'Safety chain of full trailers or converter dollies' shall be followed.

Section 9 Standard design certificate

- 9.1 All design certificates for drawbars and components shall be certified on a form approved by the Ministry of Transport. The following format is acceptable to the Ministry.
See appendix IV for format acceptable to the Ministry.

Appendix I

Design stresses

Stresses in base metals, welds and any other member associated with the drawbeam, drawbar and attachments/connections, shall be limited to allowable stresses as given in the following publications, for both the static and dynamic (fatigue) considerations.

A.S. 1250 1981 Steel Structures code and amendments

A.I.S.C. - A.W.S. 1978

Or other such approved Standards.

For the dynamic condition the stress at 2×10^6 cycles as a minimum is to be used.

It should be noted that materials such as cold-formed RHS may vary considerably in toughness, and may have significantly lower fatigue properties than the equivalent hot-formed section. In the absence of other information dynamic stresses should not exceed 100MPa for the parent metal.

“It is recommended that where carbon steel RHS is specified the material should have the following minimum charpy impact values.

| Charpy Specimen Size (mm) | Minimum Impact Value (J at -20°C) |
|----------------------------------|--|
| 2.5 x 10 | 15 |
| 5.0 x 10 | 25 |
| 7.5 x 10 | 30 |
| 10.0 x 10 | 35 |

Note - The maximum substandard or standard charpy specimen that can be machined from the material should be used”.

Appendix II

Torque figures to use for checking side strength of drawbar derived from Table 5 of SMS 2333

Maximum Single Axle Load

| Tonne | Torque kgm |
|-------|------------|
| 4 | 3700 |
| 6 | 5600 |
| 8 | 7500 |
| 10 | 9400 |
| 12 | 11,200 |
| 14 | 13,100 |
| 16 | 15,000 |

The table has been derived from the following equation:

$$\text{Torque} = \text{bogies load} \times \text{Friction factor} \times \sqrt{\frac{(\text{Track Width})^2 + (\text{Bogie Distance})^2}{2}}$$

The above table is based on a friction factor of 0.74 and a track width of 1.8 m. You may wish to use a higher friction factor, particularly in unusual circumstances.

Appendix III

Notes on the design loads used in the Code (Section 6.1.2)

The forces imposed on drawbars were measured as part of the verification of the Code. The longitudinal and transverse forces were monitored for a limited sample of truck-trailer combinations operating over a variety of routes and different driving conditions.

Peak drawbar forces have almost invariably resulted from dynamic events, such as striking the expansion joints of bridges, or roadworks, at high speed. The mean tractive force required to overcome friction, aerodynamic drag, etc., was relatively low in comparison. This has led to the emphasis in the Code on fatigue criteria.

To assist in establishing the fatigue design requirements (of 75% of the gross trailer mass) tape-recordings of drawbar forces were analysed by computer, using the 'range mean pair' method. This counts the signal 'turning points' (maxima and minima), from which load histograms can be produced. A value of 20 occurrences per hour has been used as indicative of the load or force levels likely to accrue two million cycles in the expected lifetime of the drawbar. In many cases the peak compressive loads exceeded the tensile load, but this was not exclusively so.

Many overseas Codes are written in terms of the 'D' value. While there is both theoretical and experimental evidence to support this concept, it was considered that the Code would be easier to administer if loadings were expressed in terms of the trailer weight rather than the D value. With the D value concept the operator would need to match trucks with trailers to ensure that the D value was not exceeded. The D value has been retained because overseas components are often rated in this manner.

In setting the 75% limit, account has been taken of the possibility of overloading, the sensitivity of fatigue life to the stress level, and also possible combinations of a heavy truck and a trailer with a low design gross weight.

It was noted that the longitudinal drawbar forces on empty trailers, while being less than those on the same trailer fully laden, were a considerably higher proportion of the empty trailer weight. This is believed to result from the comparatively stiff suspension when empty. The concern is that, for example, a mis-matched suspension on a fully laden trailer could result in loads higher than allowed for under the Code, hence the requirement in Section 1.4 for the trailer to be suitable for its intended use.

The transverse loads that were recorded during normal driving were invariably low, while those during manoeuvring were generally a maximum of 10% to 12% of the gross trailer weight. The one exception occurred when the trailer was deliberately jack-knifed while tipping metal, and the drawbar eye was bent.

Appendix IV

Design certificate

Certificate No.:

Vehicle Registration No.:

Vehicle Serial No.:

Owner:

This is to certify that at the time of inspection the drawbar/drawbeam, serial number is designed in accordance with N.Z.T.T.M.F.

Recommended Practice/specification and calculations, for a maximum towed mass of.....kg, and manufacture/repair/modification complies with that Practice/specification and with drawing numbersdated.....

Special Conditions:

Signed:.....

Reg. Mech. Eng.
(Reg. No.) signatory for
approved company, or
approved signatory.

Note: (a) Delete items not applicable.

(b) Current issue date to be quoted with drawing number.

Schedule 4

Bolster Attachment Code

(Revision 2 November 2010)

Section 1 INTRODUCTION

1.1 Objective

The bolster attachment system shall be designed as a total system to ensure that all loads imposed, as specified below, are reacted back to the vehicle chassis.

In particular, the Certifying Engineer shall consider all connection systems to the chassis including, but not limited to: bolts and bolt groups, twistlocks, lashings, welded fabrications, load cells, bolster pivot pins, resilient mountings and intermediate structural members. The designer shall also consider the loads the design imposes on the chassis and the bolster.

1.2 Certification life

It is expected that Design Certificates issued according to this Code should remain valid for a minimum of three years and a maximum of ten years. Samples of acceptable forms for compliance certificates are shown in the Appendix to this code.

It is permissible to use components within the bolster attachment system which may have design or service lives shorter than the life specified within the Design Certificate provided that:

- (a) The short life components are identified in detail in the Design Certificate.
and
- (b) The detail in the Design Certificate, shall have a table showing component replacement dates.
and
- (c) The Design Certificate table shall be signed off by a responsible person confirming that periodic replacement of such components has been properly carried out.

Bolster attachments may be recertified at the end of their certified life where justified on the basis of assessment by a Certifying Engineer. Any repair or modification work required to extend certified life must comply with this Code of Practice.

1.3 Proprietary components

Any proprietary components used for the purpose of bolster attachment shall be rated, approved and certified by their original manufacturer, or Certifying Engineer, as being fit for that purpose according to the loading provisions of this Code.

1.4 Repairs and modifications

Repairs and modifications to the bolster attachments should be undertaken by the original manufacturer or their authorised agent.

All modifications shall be recertified by a Certifying Engineer as in 2.8.

1.5 Vehicle and bolster identification

Individual bolsters shall be stamped, indelibly labelled or marked to clearly identify their serial number.

Individual bolster mounts shall be stamped, indelibly labelled or marked to clearly identify their serial number.

At least one tag per vehicle shall be fitted identifying the bolsters, bolster attachments, bolster rating, the certifier, the manufacturer, vehicle, and expiry date compatible with the requirements of NZS 5444.

Section 2 DEFINITIONS**2.1 Vehicle payload**

Vehicle payload shall equal the manufacturer's rated GVM minus tare, and shall not be distributed to exceed the rating on any individual component of the vehicle or vehicles.

Note: The equipment manufacturer has the right to nominate a maximum GVM less than the original vehicle manufacturer's GVM or any NZTA limitations.

2.2 Rated Bolster Load; L_R

The Rated Bolster Load is the maximum payload that the bolster may carry, and shall be the greater of:

- (a) the known load calculated as a share of the total payload for predictable configurations

or

- (b) where bolsters are loaded in a nominally equal manner or are loaded indeterminately; the bolster load shall be the total payload divided by the number of bolsters.

For different loading cases there may be different numbers of bolsters capable of resisting each load case specified. The bolster load shall be found by dividing by the number of bolsters resisting each loading case.

2.3 **Bolster Assembly Mass; D**

Bolster Assembly Mass, D shall be taken as the mass of the bolster and any other structure or securing hardware attached with the bolster.

2.4 **Design Bolster Load: Static: L_{DS} Dynamic: L_{DF}**

The Rated Bolster load calculated in 2.2 above shall be increased to allow for maldistribution within the log payload by a maldistribution of payload factor, M, for static loadings only, where

$M = 1.2$ for all static loads on longs bolsters

$M = 1.2$ longitudinal loading calculations

$M = 1.4$ otherwise

So; $L_{DS} = M \times L_R + D$ and $L_{DF} = L_R + D$

2.5 **Loads**

Where the term 'g' is used this shall be taken as $g = 9.81 \text{ m/s}^2$. All other variables or quantities shall be taken as measured in SI units unless specified.

Dynamic loads expressed in this Code are given as (Fatigue) Dynamic Load Ranges from which Fatigue Stress Ranges can be calculated and compared with allowable stress ranges.

Static loads are expressed as peak static loads in either direction (ie: up/down, left/right, tension/compression) from which peak static stresses can be calculated and compared with allowable stress levels. All loads shall be applied independently of any other design loads (ie: none shall be considered simultaneous).

Also, fatigue cycle counts in each mode of loading shall be considered independent of every other mode.

The load cycles are therefore to be counted as though no other mode of loading exists.

2.6 General design requirements

Design shall be to AS 3990 for both static and dynamic loadings or alternatively to AS 3990 for static loading and to BS 5400 PT10 or BS7608 for dynamic loading.

Guidance on allowable stresses for materials other than those permitted under these standards should be sought from reputable internationally recognised Standards.

For the dynamic condition the stress at 2×10^6 cycles is to be used (in AS3990, loading condition 3 applies), based on an expected 10-year life. Where applicable a probability of failure of 2.3% should be used. In certain cases, a higher probability of failure could be acceptable, for example, where fatigue cracking would not have serious consequences and where a crack could be easily located and repaired. It is permissible to use shorter design life or components with shorter design life provided that any such component is identified as per Section 1.2.

Where any component is likely to be damaged, worn or distorted during normal operational wear and tear, the Engineer shall select a fatigue stress level, class or category appropriate to the probable damaged condition. The Engineer shall not base allowable stress levels upon the as-new undamaged condition.

At the discretion of the Certifying Engineer a maximum service life may be specified on the Design Certificate.

2.7 Load centre

The Load Centre shall be assumed to exist at the geometric centroid of the area bounded by the bolster bed, inner faces of the stanchions and a horizontal line across the tips of the stanchions or extension pins, if fitted.

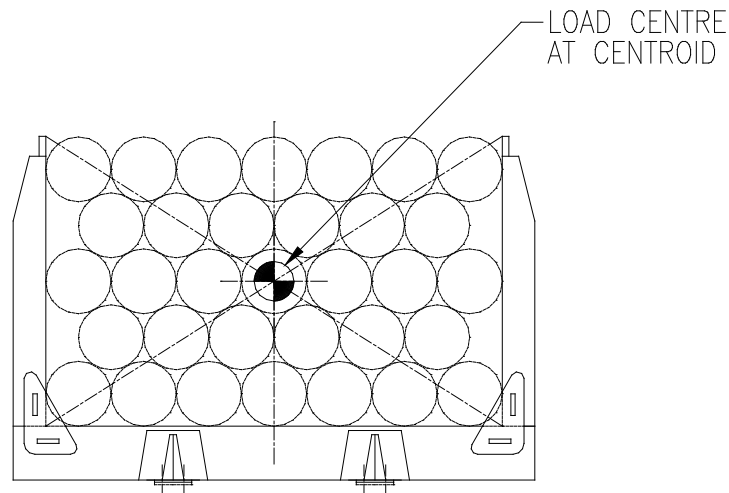

Figure 1: Determination of the load centre position

2.8 Certifying Engineer

The Certifying Engineer (HVEL category) shall be approved by the Director on the recommendation of the Log Transport Safety Council.

2.9 Longs Bolster

Longs bolsters are designed to support logs suspended between separate towing and towed vehicles. Their mounting system allows for articulation between the vehicles.

2.10 Shorts Bolster

For the purposes of this Code, a shorts bolster is one designed to support, in conjunction with one or more other bolsters, a log packet carried on a single vehicle.

2.11 Convertible (longs/shorts) vehicle

A vehicle capable of being used in both longs and shorts operation. The bolster mounting system is able to be rapidly reconfigured to suit either mode.

Section 3 VERTICAL LOADS

3.1 Application

The static and dynamic vertical loads shall be applied as a uniformly distributed load across the top of the bolster bed, equal in total to the values specified below.

The weight of the bolster and attachments may be ignored for vertical loadings.

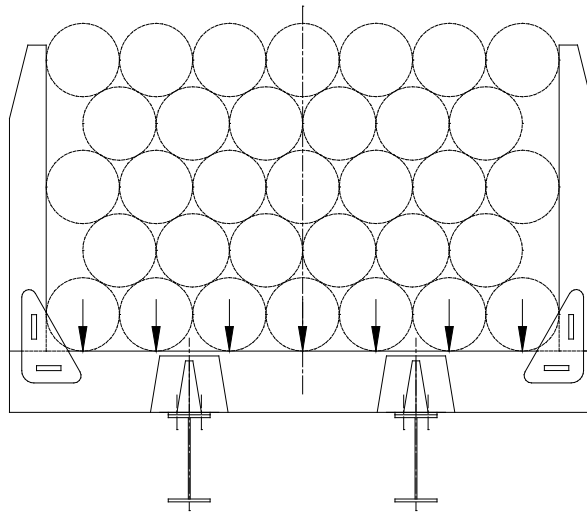

Figure 2: Application of vertical loads

3.2 Static Vertical Load; P_v

Downwards: $P_v = L_{DS} \times 2.5 \text{ g}$

Upwards: $P_v = L_{DS} \times 0.5 \text{ g}$

3.3 Dynamic Vertical Load Range; Q_v

$Q_v = L_{DF} \times 2.0 \text{ g}$ (ie $\pm 1.0 \text{ g}$)

Section 4 TRANSVERSE LOADS

4.1 Application

The static and dynamic transverse loads shall be applied as forces at the load centre as in *Figure 3* below.

Weight due to gravity @1 g may be superimposed as a uniformly distributed load (UDL) across the bolster to help resist transverse loadings.

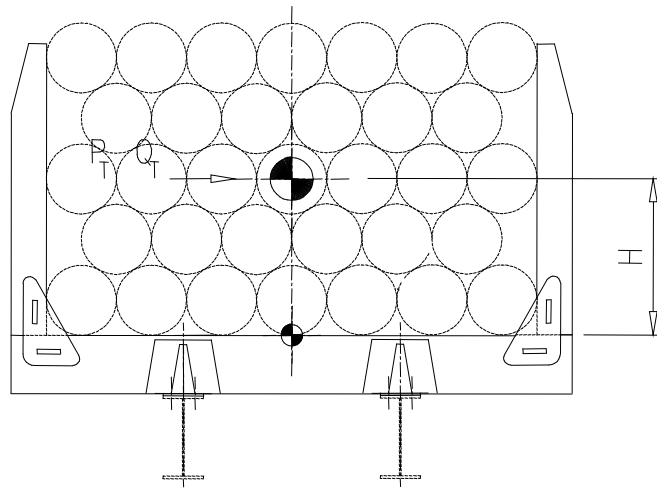

Figure 3: Application of transverse loads

4.2 Static Transverse Load; P_T (*applies at the Load Centre*)

$$P_T = L_{DS} \times \pm 0.5 \text{ g}$$

4.3 Dynamic Transverse Load; Q_T (*applies at the Load Centre*)

$$Q_T = L_{DF} \times 1.7 \text{ g (ie. } \pm 0.85 \text{ g)}$$

Section 5 LONGITUDINAL LOADS

5.1 Application

Longitudinal loading shall be checked in each of four cases

- 2 dynamic Q_{L1} , Q_{L2}
- 2 static P_{LF} , P_{LR}

as detailed below and weight due to gravity @1 g may be superimposed as a UDL across the bolster to help resist longitudinal loadings.

5.2 Static Longitudinal Loads P_{LF} , P_{LR}

Forwards: $P_{LF} = L_{DS} \times 1 \text{ g}$

Applied 300 mm above bolster bed height.

Rearwards: $P_{LR} = L_{DS} \times 0.5 \text{ g}$

Applied at the bolster bed height.

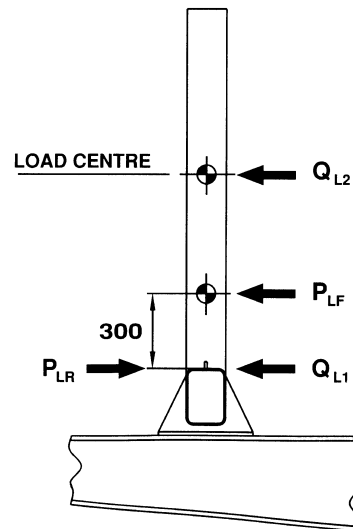

Figure 4: Application of longitudinal loads

5.3

Dynamic Longitudinal Loads; Q_{L1} ; Q_{L2}

$$Q_{L1} = L_{DF} \times 2.0 \text{ g (ie. } \pm 1.0 \text{ g)}$$

Applied at Bolster Bed Height

$$Q_{L2} = L_{DF} \times 0.25 \text{ g (ie. } \pm 0.125 \text{ g)}$$

Applied at Load Centre

Section 6

SPECIAL TYPES OF BOLSTER MOUNTINGS

The design loads specified in sections 3.0, 4.0 and 5.0 were specifically measured as being applicable to bolsters, of high torsional and bending stiffness, rigidly mounted onto a relatively flexible chassis structure.

A wide variety of configurations exists, and may expand in the future, where the connection between the bolster unit and chassis has some measure of compliance in torsion and/or linear location.

In recognition of the fact that:

- (a) Not every configuration can be effectively tested and
- (b) The impact and torsion induced loadings on such arrangements are significantly reduced, the Dynamic loadings Q_V , Q_T and Q_{L1} and Q_{L2} (as defined in 3.0, 4.0 and 5.0) shall be reduced as follows:
 - (i) for all bolts and fasteners the dynamic loads shall be reduced by 50%

- (ii) for welds the dynamic loads may be taken as being sufficiently low as not to require detailed fatigue design. However, dynamic loads do exist and good fatigue detail design practice should be followed
- (iii) for all other parts of the restraint system the dynamic loads may be taken as zero. Good fatigue detail design practice should be followed.

The reduced dynamic loadings shall only apply to the following types of bolster attachment as defined below. Physical testing may be required to confirm compliance with these definitions.

6.1 Torsionally Independent Bolsters

Typically bolster types relying upon either gravity or resiliently restrained bolts to resist the longitudinal loads. The main connection to the chassis allows torsional displacement of the chassis rails without loading of the bolster bed through the attachment.

A minimum total of 2 degrees angular displacement between the bolster and each chassis rail in the longitudinal vertical plane (see *Figure 5*), with an increase in contact loads not exceeding 10 kNm/degree between bolster and chassis members, shall be achieved.

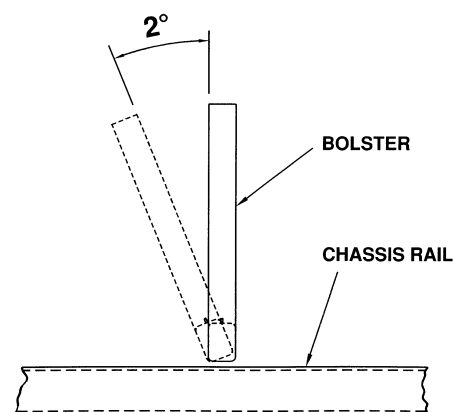

Figure 5: Angular displacement requirement for torsionally independent bolster attachments (not to scale).

6.2 Sliding Bolsters

Bolsters mounted on sliding attachments where sufficient clearance exists to meet a minimum ± 1 degrees angular displacement (see *Figure 6*), with an increase in contact loads not exceeding 20 kNm/degree between bolster and chassis members.

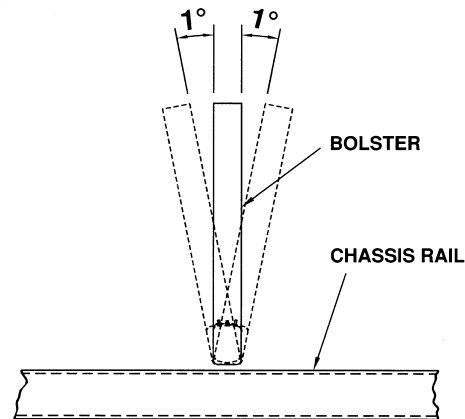

Figure 6: Angular displacement requirement for sliding & resilient bolster attachments (not to scale).

6.3 Resiliently Mounted Bolsters

Resiliently mounted bolsters are those for which the incremental rotational stiffness does not exceed 20 kNm/degree (per attachment) for an angular displacement of ± 1 degree about the transverse axis (see *Figure 6*).

Typically these bolsters will be elastomeric or metal spring mounted with overriding solid connections to prevent excessive displacement.

The term "incremental stiffness" is intended to allow for preloading of resilient mounts such that static deflections under rated loads can be minimized, whilst maintaining relatively low natural frequencies at the loaded condition.

6.4 Longs and Convertible Units

Bolster mounting systems or individual bolster mounts on vehicles designed for longs or longs/shorts (convertible) operation and which are new into service after 31/3/2005 must comply with either section 6.4.1 or 6.4.2 below.

6.4.1 Type Approval

Bolster attachment systems or individual bolster mounts on longs or convertible logging vehicles may be considered to comply with this Code, provided that the manufacturer (who must also be an HVML manufacturing certifier) or an HVEL certifying engineer has evidence available for audit by the Director that the particular design of the bolster attachments has successfully completed, on a single vehicle, 250,000 kilometres of service without any indication of cracking due to fatigue or other significant failure.

For each vehicle incorporating this design, at least one "Statement of Compliance with Type Approved Design" (see Appendix) must be signed and referred to in the Heavy Vehicle Compliance Certificate (LT400) which is issued at the time of first presentation of the vehicle for registration. Expiry date of certification is to be within the period stated in section 1.2.

6.4.2 Certification by calculation

In general, the loads specified in sections 3, 4, 5 and 6 of this Code shall be applied, with the following provisions and exceptions:

The longs bolster shall be able to rotate fore and aft about its transverse axis by at least $\pm 5^\circ$ where the incremental stiffness of the bolster attachment does not exceed 20 kNm/degree of angular displacement (see *Figure 7*).

Side to side rotation of the longs bolster about the longitudinal axis of the vehicle shall be limited to avoid instability.

Provision shall be made for the longs bolster to rotate about its vertical axis. This may be done utilising a standard trailer dolly ballrace turntable or slewring. The Engineer shall justify the rating of the ballrace turntable or slewring by applying the turntable manufacturer's requirements for the longs logging application using the static loadings specified in sections 3, 4 and 5 and the reduced dynamic loadings specified in 6.0.

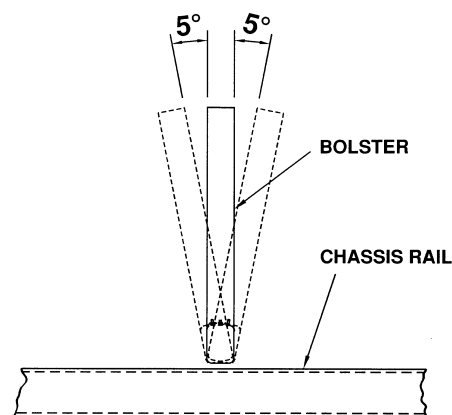

Figure 7: Angular displacement requirement for longs bolster attachments (not to scale).

In the absence of these requirements, the design bolster load, L_{DF} shall not exceed 1.25 times the manufacturer's static vertical rating for the turntable or slewring when used on a trailer dolly.

The ballrace turntable or slewring shall be supported over at least 50% of the circumferential area of both top and bottom

rings, with detailed design of the bolting being carried out by the Engineer.

Where ballrace turntables or slewrings designed for trailer dollies are not used, the loads specified in sections 3, 4, 5 and 6 of this Code shall be applied.

Section 7 DESIGN OF BOLTED CONNECTIONS

For some detail arrangements of bolster attachments, some bolted connections may rely on the provision and maintenance of pre-tensioned axial loads to avoid premature failure of the bolt(s) or joint. In such critical applications the manufacturer and/or Certifying Engineer shall specify and ensure the provision of:

- (a) correct bolt size, grade, type, thread form
- (b) installation procedure (e.g. torques, tightening procedures)
- (c) retention devices or system to retain nuts, studs, unless deemed by the designer to be unnecessary for the design
- (d) data plate permanently fixed to the vehicle close to the bolts and detailing information a, b and c above.

Bolt design shall be undertaken by the following means:

- (a) by the manufacturer of proprietary specialised components (e.g. load cell manufacturer) by design calculation and/or testing to the loading provisions of this Code, where applicable;

otherwise

- (b) bolts subject to dynamic loads predominantly in the axial direction shall be designed to BS 7608

and

- (c) bolts subject predominantly to dynamic shear loads shall be designed to AS 3990

and

- (d) where bolts have been fitted in holes with clearance on diameter of less than 0.1 mm, then, for the purposes of this Code, the joint needs to be designed to avoid slip in accordance with AS 3990 Appendix F section F3 in the dynamic load case only. The Engineer shall establish the appropriate slip factor to use for the bolt torques specified.

The bolts shall still be separately designed for the full static loads, but in this case limited slip is permissible.

and

- (e) non metric bolts, to a suitable recognised standard, for example, S.A.E., may be substituted for metric bolts referred to in AS 3990 and BS 7608 provided they meet the loadings imposed in terms of this Code.

Section 8 WELDING CONSIDERATIONS

All welding shall comply with AS/NZS 1554.1 or for quenched and tempered steels AS/NZS 1554.4. The required weld categories (GP, SP or FP) shall be stated on the drawings.

Section 9 SECONDARY ATTACHMENT DEVICES

Where an existing primary attachment does not meet the requirements of this Code it is permissible to fit a secondary independent bolster attachment system to ensure restraint of the bolster should the primary system fail. The secondary attachment device is permissible for bolsters manufactured and fitted to vehicles before the introduction of this Code.

The secondary system shall:

- (a) be capable of meeting the load and stress requirements of clauses 3.2, 4.2, 5.2 and clause 2.6 for static loadings only;

and

- (b) be used only to provide emergency restraint to the bolster(s) until the primary system is immediately and permanently repaired;

and

- (c) restraining the bolster in position under load, not exceeding 10 mm linear displacement in any direction, or ± 5 degrees angular displacement, from the normal unloaded bolster position.

Appendix
Sample forms of NZTA approved acceptable design
certificates

Engineers or Company Letterhead - including name, physical address plus postal address, phone, fax etc

Bolster Attachment Code:

Certificate of Installation/ Repair Compliance

Certificate No.

Certificate Expiry.....(Minimum three years, maximum ten years.)

Job/File No(Engineer must record in a Bolster attachment code register.)

Vehicle Make Vehicle Model

Vehicle Registration No.....(Not required for new entry vehicles.)

Vehicle Chassis/VIN No.

Owner

Maximum Payload of Logs Allowable on Vehicle

Maximum Vehicle Mass Allowable When Carrying Logs

Applicable Certificate of Design Compliance

Applicable Certificate of Manufacture Compliance

Installation Specification followed

Bolster attachments do/ do not (delete one) rely on secondary attachment devices.

| Bolster type and location | Bolster Serial No | Bolster attachment serial no | Load cell serial no | Drawing Number/ Numbers | Bolster attachment expiry date* | Maximum Log Load Permitted in Bolster (kg) |
|---------------------------|-------------------|------------------------------|---------------------|-------------------------|---------------------------------|--|
| | | | | | | |
| | | | | | | |
| | | | | | | |
| | | | | | | |

*Date of certification expiry for bolster attachment as a whole.

This is to certify that the bolster attachments identified above comply with the requirements of the Bolster Attachment Code. (Bolster Attachment Code refers to the Log Transport Safety Committee, Bolster Attachment Code (Latest version).)

The only standards and codes of practice used are those referenced in the Bolster Attachment Code.

Certificate No..... Page 1 of 2 Signed.....

- 1.1 I have clearly established that all of the design required in accordance with the Bolster Attachment Code has been carried out.
- 1.2 I have sound reason to believe that I have fully understood all of the designers and manufacturers intentions and requirements.
- 1.3 The installation is in accordance with the Bolster Attachment Code, and as detailed in drawings and instructions.
- 1.4 I have inspected the complete bolster attachment installation/ repair (delete as applicable) on the above vehicle. Visual inspection indicates that all work complies with the codes, standards, instructions and drawings.
- 1.5 All the bolster attachment designer’s installation instructions and drawings are held in the above file.
- 1.6 All welding complies with NZS 1554 and/or any NZTA endorsed welding publication.
- 1.7 Bolster attachment components with a shorter life than bolster attachment as a whole are as the following table:-

| Bolster Attachment Serial Number | Components | Scheduled replacement interval | Replacement Made by | Date Replacement Made | Signature |
|----------------------------------|------------|--------------------------------|---------------------|-----------------------|-----------|
| | | | | | |
| | | | | | |
| | | | | | |
| | | | | | |

*The Bolster serial number is issued by the bolster manufacturer.
 The designer shall identify the components.
 Designer to state component life. Installer to state replacement date.
 Modifications are design changes, and require a new Certificate of Compliance.*

Installation/ Repair Company

Welder NameWelder Number

Signed Name..... Date: / /

Certifying Engineer, Category HVEL/HVML, Approval Number.....

Certificate No..... Page 2 of 2 Signed.....

Engineers or Company Letterhead - including name, physical address plus postal address, phone, fax etc

Bolster Attachment Code: Certificate of Manufacture Compliance

Certificate No.

Certificate Expiry(Minimum three years, maximum ten years.)

Job/File No (Engineer must record in a Bolster attachment code register.)

Vehicle Make Vehicle Model

Vehicle Registration No.....(Not required for new entry vehicles.)

Vehicle Chassis/VIN No.

Owner

Maximum Payload of Logs Allowable on Vehicle

Maximum Vehicle Mass Allowable When Carrying Logs

Applicable Certificate of Design Compliance

Design Specification followed for manufacture.....

Specification to be followed for Installation.....

Extent of Components covered by this Certificate

Bolster attachments do/ do not (delete one) rely on secondary attachment devices.

| Bolster type and location | Bolster Serial No | Bolster attachment serial no | Load cell serial no | Drawing Number/ Numbers | Bolster attachment expiry date* | Maximum Log Load Permitted in Bolster (kg) |
|---------------------------|-------------------|------------------------------|---------------------|-------------------------|---------------------------------|--|
| | | | | | | |
| | | | | | | |
| | | | | | | |
| | | | | | | |

*Date of certification expiry for bolster attachment as a whole.

This is to certify that the bolster attachments identified above comply with the requirements of the Bolster Attachment Code. (Bolster Attachment Code refers to the Log Transport Safety Committee, Bolster Attachment Code (Latest version).)

The only standards and codes of practice used are those referenced in the Bolster Attachment Code.

Certificate No..... Page 1 of 2 Signed.....

- 1.1 These attachments will only perform to the requirement of the Bolster Attachment Code when they have been installed to the approved installation drawings and when the installation has been verified and endorsed by an approved Engineer.
- 1.2 I have clearly established that all of the design required for manufacture in accordance with the Bolster Attachment Code has been carried out.
- 1.3 I have sound reason to believe that I have fully understood all of the designers intentions and requirements.
- 1.4 The manufacture has been carried out in accordance with the Bolster Attachment Code, and as detailed in drawings and instructions.
- 1.5 I have inspected the bolster attachment components. Visual inspection indicates that manufacture complies with the codes and standards listed and with drawings.
- 1.6 All drawings (general arrangement, components, & systems), component specifications, and fabricator instructions as applicable are held in the above file.
- 1.7 Welding complies with NZS 1554 and/or any NZTA endorsed welding publication.
- 1.8 Bolster attachment components with a shorter life than bolster attachment as a whole are as the following table:—

| Bolster Attachment Serial Number | Components | Scheduled replacement interval |
|----------------------------------|------------|--------------------------------|
| | | |
| | | |
| | | |

The Bolster serial number is issued by the bolster manufacturer.

Manufacturer

Welder Name Welder Number

Signed Name..... Date: / /

Certifying Engineer, Category HVEL/HVML, Approval Number

Certificate No..... Page 2 of 2 Signed.....

Engineers or Company Letterhead - including name, physical address plus postal address, phone, fax etc

Bolster Attachment Code: Certificate of Design Compliance

Certificate No.

Certificate Expiry *(Minimum three years, maximum ten years.)*

Job/File No *(Engineer must record in a Bolster attachment code register.)*

Bolster Attachment Type

Drawing Numbers.....

Manufacture Specification

Installation Specification

Extent of components covered by this certificate

Extent of design covered by this certificate.....

Maximum Log Load Permitted in Bolster (kg)

Maximum Bolster Bed Height Covered by Design

Bolster Attachment Design Life.....

This is to certify that the bolster attachments identified above comply with the requirements of the Bolster Attachment Code. *(Bolster Attachment Code refers to the Log Transport Safety Committee, Bolster Attachment Code (Latest version).)*

The only standards and codes of practice used are those referenced in the Bolster Attachment Code.

- 1.1 The bolster attachments detailed above have been designed in accordance with the Bolster Attachment Code.
- 1.2 These attachments will only perform to the requirement of the Bolster Attachment Code when they have been manufactured and installed to the approved installation drawings and when the installation has been verified and endorsed by an approved Engineer.
- 1.3 All design analysis, calculations, drawings (general arrangement, components, & systems), component specifications, and fabricator instructions are held in the above file.

Certificate No..... Page 1 of 2 Signed.....

1.4 All installation instructions and drawings are held in the above file.

1.5 Bolster attachment components with a shorter life than bolster attachment as a whole are as the following table:—

| Bolster Attachment Type | Components | Scheduled replacement Interval |
|-------------------------|------------|--------------------------------|
| | | |
| | | |
| | | |
| | | |

Signed Name..... Date: / /

Certifying Engineer, Category HVEL, Approval Number

**Engineers or Company Letterhead - including name, physical address plus
postal address, phone, fax etc**

Bolster Attachment Code: Certificate of Compliance

Certificate No.

Certificate Expiry (Minimum three years, maximum ten years.)

Job/File No(Engineer must record in a Bolster attachment code register.)

Vehicle Make Vehicle Model

Vehicle Registration No.....(Not required for new entry vehicles.)

Vehicle Chassis/VIN No.

Owner

Maximum Payload of Logs Allowable on Vehicle

Maximum Vehicle Mass Allowable When Carrying Logs

Bolster attachments do/ do not (delete one) rely on secondary attachment devices.

| Bolster type and location | Bolster Serial No | Bolster attachment serial no | Load cell serial no | Drawing Number/ Numbers | Bolster attachment expiry date* | Maximum Log Load Permitted in Bolster (kg) |
|---------------------------|-------------------|------------------------------|---------------------|-------------------------|---------------------------------|--|
| | | | | | | |
| | | | | | | |
| | | | | | | |
| | | | | | | |

*Date of certification expiry for bolster attachment as a whole.

This is to certify that the bolster attachments identified above comply with the requirements of the Bolster Attachment Code. (Bolster Attachment Code refers to the Log Transport Safety Committee, Bolster Attachment Code (Latest version).)

Certificate No..... Page 1 of 4 Signed.....

The only standards and codes of practice used are those referenced in the Bolster Attachment Code.

This certificate is only valid when signed in all three locations; section 1, 2 and 3.

1 Bolster Attachment Design Certification

(Including Any Secondary Attachment Devices)

- 1.1 The bolster attachments detailed above have been designed in accordance with the Bolster Attachment Code.
- 1.2 These attachments will only perform to the requirement of the Bolster Attachment Code when they have been manufactured and installed to the approved installation drawings and when the installation has been verified and endorsed by an approved Engineer.
- 1.3 All design analysis, calculations, drawings (general arrangement, components, & systems), component specifications, and fabricator instructions are held in the above file.
- 1.4 All installation instructions and drawings are held in the above file.

Signed Name..... Date: / /

Certifying Engineer, Category HVEL, Approval Number

2 Manufacture Certification

- 2.1 I have clearly established that all of the design required for manufacture in accordance with the Bolster Attachment Code has been carried out.
- 2.2 I have sound reason to believe that I have fully understood all of the designers intentions and requirements.
- 2.3 The manufacture has been carried out in accordance with the Bolster Attachment Code, and as detailed in drawings and instructions.
- 2.4 I have inspected the bolster attachment components. Visual inspection indicates that manufacture complies with the codes and standards listed and with drawings.
- 2.5 All drawings (general arrangement, components, & systems), component specifications, and fabricator instructions as applicable are held in the above file.

Certificate No.....Page 2 of 4 Signed.....

2.6 Welding complies with NZS 1554 and/or any NZTA endorsed welding publication.

Manufacturer

Welder NameWelder Number

Signed Name..... Date: / /

Certifying Engineer, Category HVEL/HVML, Approval Number

3 Installation/ Repair Certification

- 3.1 I have clearly established that all of the design required in accordance with the Bolster Attachment Code has been carried out.
- 3.2 I have sound reason to believe that I have fully understood all of the designers and manufacturers intentions and requirements.
- 3.3 The installation is in accordance with the Bolster Attachment Code, and as detailed in drawings and instructions.
- 3.4 I have inspected the complete bolster attachment installation/ repair (delete as applicable) on the above vehicle. Visual inspection indicates that all work complies with the codes, standards, instructions and drawings.
- 3.5 All the bolster attachment designer’s installation instructions and drawings are held in the above file.
- 3.6 All welding complies with NZS 1554 and/or any NZTA endorsed welding publication.

Installation/ Repair Company

Welder NameWelder Number

Signed Name..... Date: / /

Certifying Engineer, Category HVEL/HVML, Approval Number

Certificate No..... Page 3 of 4 Signed.....

4 Special Conditions

Bolster attachment components with a shorter life than bolster attachment as a whole.

| Bolster Attachment Serial No | Components | Scheduled replacement interval | Replacement Made by | Date Replacement Made | Signature |
|------------------------------|------------|--------------------------------|---------------------|-----------------------|-----------|
| | | | | | |
| | | | | | |
| | | | | | |
| | | | | | |

The Bolster serial number is issued by the bolster manufacturer.

The designer shall identify the components.

Designer to state component life. Installer to state replacement date.

Modifications are design changes, and require a new Certificate of Compliance.

4.2

4.3

Engineers or Company Letterhead - including name, physical address plus postal address, phone, fax etc

Bolster Attachment Code:

Certificate of Manufacture Compliance

Certificate No. File No.....*(manufacturer)/.....(certifier)

This is to certify that I have inspected the bolster attachment components manufactured by.....as identified below. Visual inspection indicates that manufacture has been carried out in strict accordance with the design requirements of Certificate of Component Design Compliance numberwhich covers bolster attachment components built to(drawing issuer) drawing number

Job number..... Date of manufacture.....

Description of component

.....
.....
.....

Component Serial

Numbers*.....
.....
.....
.....

Compliance Conditions and Explanatory Notes

- *1 The manufacturer’s certifying engineer must record the above file and serial numbers in a Bolster Attachment Code register.
- 2. Bolster Attachment Code refers to the LTSA-approved Log Transport Safety Committee Bolster Attachment Code.
- 3. These attachment components will only comply with the requirement of the Bolster Attachment Code when they have been installed to the approved installation drawings as part of a complete bolster-to-chassis attachment system and when the installation has been verified and endorsed by an approved Engineer.
- 4. I have established that all of the requirements specified in the design documents have been carried out and that the designer’s drawings and requirements have been clearly understood by the manufacturer and the manufacturer’s certifying engineer.

Certificate No..... Page 1 of 2 Signed.....

- 5. All drawings (general arrangement, components, & systems), component specifications, fabricator instructions, records of manufacture & inspection as applicable are held in the above file(s).
- 6. Welding complies with NZS 1554 and/or any NZTA endorsed welding publication.

Welder Names and NZS 1554

numbers.....

I have fully understood and carried out all of the above requirements.

Signed Name..... Date: / /

Certifying Engineer, Category HVEL/HVML, Approval Number

Design certifier/Manufacturer copy No. 6

Engineer’s or Company Letterhead – including name, physical address plus postal address, phone, fax, etc

Bolster Attachment Code

Certificate of Design Compliance

Certificate No.

This certificate covers the design of the rigid/resilient/sliding/torsionally independent (*delete not applicable*) logging bolster attachment components as detailed on Drawing Number(s)

.....

for manufacture by.....

All Manufacturing, Installation and Operational instructions relevant to the above component design are specified in the above drawing(s).

All design analysis, calculations, drawings (general arrangement, components, & systems), component specifications, and fabricator instructions are held in Job/File No.....at(*Engineer must record in a Bolster Attachment Code register.*)

Bolster attachment group description.....
.....
.....

Extent of components covered by this certificate
.....
.....

Extent of design covered by this certificate.....
.....

Bolster base dimensions approved for use with this design:- width..... height (*Refer to the above drawing for further details of bolster compatibility requirements.*)

This design is approved for use in conjunction with loadcell make & model number (if applicable):
.....

Maximum Certificate Life of a bolster attachment containing any components built to this design isyears

Design Life of a bolster attachment containing any components built to this design isyears

(*Minimum three years, maximum ten years.*)

Certificate No.....Page 1 of 3 Signed.....

Maximum Log Load Permitted in Bolsterkg (note that this may be further limited by the nature of the total bolster attachment system in which the component design is used – refer to installation certificate)

This certificate is valid for use by the above designated manufacturer until or until any revision of the current Bolster Attachment Code dated (whichever is sooner), after which time no new components may be manufactured under this certificate until the design has been reassessed by an HVEL engineer and re-certified.

I,, hereby certify (not to be construed as a guarantee) that the bolster attachment component design as identified above complies with the requirements of the Bolster Attachment Code and all standards and codes of practice referred to therein, subject to the following conditions.

Note

1. Bolster Attachment Code refers to the LTSA-approved Log Transport Safety Committee Bolster Attachment Code.
2. This certificate covers the design only of a component or components of a total bolster attachment system. The attachment component(s) has/have been designed to be manufactured and installed as part of a complete bolster attachment system which will comply with the Bolster Attachment Code only when this and all other components of the system have been separately certified as being designed, manufactured and installed in accordance with the Code by an approved HVEL Engineer.
3. This certificate is therefore invalid unless accompanied by (a) a certificate of manufacture for any component built to the above drawing and (b) a certificate of compliance (with original signature of installation certifier) covering the installation of that component on a vehicle, including any design and manufacture work involved in the installation.
4. Any change or revision to the above drawing or its sub-drawings or specifications invalidates this certificate for new construction.
5. Any change to the above drawing or its sub-drawings or specifications must be approved by a HVEL certifying engineer and a new design certificate issued.
6. The following table specifies parts belonging to the above bolster attachment component(s) which have a shorter design life than stated above:- (also included are any short-life items which interface to the above certified components e.g. bolts).

Certificate No.....

Page 2 of 3

Signed.....

| <i>Part</i> | <i>Scheduled replacement Interval</i> | <i>Replacement instructions</i> |
|-------------|---------------------------------------|---------------------------------|
| | | |
| | | |
| | | |
| | | |

7. Acceptance of this certificate by the manufacturer and/or manufacturing certifier implies an obligation to inform the original design certifying engineer of any manufacturing problems, in-service defects or failures which may arise.
8. The above drawing number(s) are issued by
9. An original of this design certificate must be held by the manufacturer and will be invalid for new manufacture of components to the above design without the design certifier's and manufacturer's original signatures below.

.....

Signed Print full Name.....Date:...../...../.....

Certifying Engineer, Category HVEL, Approval Number

I,of(manufacturer) hereby accept the terms and conditions of the above certificate.

Signed..... Date...../...../.....

Design certifier/Manufacturing certifier/Installation certifier/Owner/VTNZ copy

No. 7

Engineers or Company Letterhead - including name, physical address plus postal address, phone, fax etc

Bolster Attachment Code:

Certificate of Compliance

Certificate No.

Certificate Expiry*Minimum is three years from date of issue, maximum ten years. (Date of certification expiry for vehicle bolster attachment installation as a whole, excluding any short-life components listed in Table C)*

Certifier’s Job/File No*(Engineer must record in a Bolster Attachment Code register.)*

Vehicle Make & Model

Registration No.....Chassis/VIN No.

Owner

Maximum Payload of Logs Allowable on Vehicle (kg).....

Maximum Vehicle Mass Allowable When Carrying Logs (kg)

Table A: Vehicle Bolster attachment systems

| Bolster type and location | Bolster Serial No | Design relies on Secondary Attachment device(s) (yes/no) | Drawing Number/ Numbers specifying manufacturing, installation and operating instructions for total bolster to chassis attachment | Log Payload Rating per Bolster (kg) |
|---------------------------|-------------------|--|---|-------------------------------------|
| | | | | |
| | | | | |
| | | | | |
| | | | | |

In the event of replacement of individual bolsters attachments, individual lines may be crossed out in the above table but a new compliance certificate must be issued for the replacement bolster attachment.

Certificate No.....

Page 1 of 5

Signed.....

Notes:.....

This is to certify that the bolster attachments identified above comply with the requirements of the Bolster Attachment Code and all standards and codes of practice referred to therein.
(Bolster Attachment Code refers to the LTSA-approved Log Transport Safety Committee Bolster Attachment Code, current version.)

This certificate is only valid when signed in all three sections 1, 2 and 3.

1 Bolster Attachment Design Certification

(Including any Secondary Attachment Devices)

- 1.1 I have designed the bolster attachment systems detailed in Table A above, (except for those pre-certified components or subassemblies covered in Table B), in accordance with the Bolster Attachment Code.
- 1.2 These attachments will only comply with the requirements of the Bolster Attachment Code when they have been manufactured and installed to the approved installation drawings and when the installation has been verified and endorsed by an HVEL-approved Engineer.
- 1.3 All design analysis, calculations, drawings (general arrangement, components, & systems), component specifications, and fabricator instructions are held in the above file.
- 1.4 All installation instructions and drawings are held in the above file.
- 1.5 Separate certificates of design are attached covering the design of the following components or subassemblies used in above bolster attachments:

Table B: Pre-Certified Components or subassemblies

| Bolster serial number | Bolster attachment component drawing number | Bolster attachment component description and extent of design covered | Manufacturer of pre-certified components | Component serial number |
|-----------------------|---|---|--|-------------------------|
| | | | | |
| | | | | |
| | | | | |
| | | | | |

Certificate No..... Page 2 of 5 Signed.....

1.6 All the component or subassembly designer’s recommendations, instructions and drawings for the interface of any Table B components with the bolster attachment systems listed in Table A have been complied with insofar as the design of the bolster attachment as a whole is concerned. All such recommendations, instructions and drawings are held on the above file.

1.7 Modifications are design changes, and require a new Certificate of Compliance.

Signed

Name..... Date:/...../.....

Certifying Engineer, Category HVEL, Approval Number

2 Manufacture Certification

Manufacturer Manufacturer’s job number.....

Welder Name(s) and NZS 1554 number(s).....

2.1 I have clearly established that all of the design required for manufacture in accordance with the Bolster Attachment Code has been carried out.

2.2 I have sound reason to believe that I have fully understood all of the designers intentions and requirements.

2.3 The manufacture has been carried out in accordance with the Bolster Attachment Code, and as detailed in the design certifier’s drawings and instructions.

2.4 I have inspected the bolster attachment components. Visual inspection indicates that manufacture complies with the drawings listed in Table A.

2.5 All manufacturing drawings (general arrangement, components, & systems), component specifications, fabricator instructions, inspection records & photographs as applicable are held in file (Engineer must record in a Bolster Attachment Code register)

2.6 Welding complies with NZS 1554 and/or any NZTA endorsed welding publication.

2.7 Separate certificates of manufacture are attached covering any pre-certified subassemblies or components identified in Table B which have been used in the above bolster attachments.

Signed.....

Name..... Date:/...../.....

Manufacturer Certifying Engineer, Category HVEL/HVML, Approval Number

3 Installation/Repair Certification

Installation/ Repair Company

Installation Company File NoInstallation company job no.....

Welder Name(s) and NZS 1554 Number(s)

- 3.1 I have clearly established that all of the design required in accordance with the Bolster Attachment Code has been carried out.
- 3.2 I have sound reason to believe that I have fully understood all of the designers and manufacturers intentions and requirements.
- 3.3 The installation is in accordance with the Bolster Attachment Code, and as detailed in the installation drawings and instructions specified in Table A.
- 3.4 I have inspected the complete bolster attachment installation/ repair (delete as applicable) on the above vehicle. Visual inspection indicates that all work complies with the codes, standards, instructions and drawings.
- 3.5 All the bolster attachment designer’s installation instructions and drawings, and installation inspection records are held in Installation Certifier’s File no.....(*Engineer must record in a Bolster Attachment Code register.*)
- 3.6 All welding complies with NZS 1554 and/or any NZTA endorsed welding publication.

Table C: Bolster attachment components with a shorter life than bolster attachment as a whole.

| Bolster Serial Number | Bolster attachment components | Scheduled replacement date | Replacement carried out by | Date replacement carried out | Signature |
|-----------------------|-------------------------------|----------------------------|----------------------------|------------------------------|-----------|
| | | | | | |
| | | | | | |
| | | | | | |
| | | | | | |

**The Bolster serial number is issued by the bolster manufacturer.*

***The installation certifying engineer shall identify bolster, components, replacement dates. Continue on separate sheet if necessary.*

****Company carrying out replacement shall obtain and follow all replacement instructions from the installation company.*

Certificate No..... Page 4 of 5 Signed.....

Notes.....
.....
.....

SignedName..... Date:/...../.....

Installation Certifying Engineer, Category HVEL/HVML, Approval Number ...

Certificate No..... Page 5 of 5 Signed.....

Engineers or Company Letterhead - including name, physical address plus postal address, phone, fax etc

No 8

**STATEMENT OF COMPLIANCE WITH
TYPE APPROVED DESIGN**

Certificate No.

Job/Project File Reference:

Vehicle Details : Make.....

Model.....

VIN.....

Operator Details :.....

Iof hereby certify that the
bolster attachment system / individual bolster attachment (delete one) detailed in drawing(s):
.....
.....
and incorporated in the above vehicle is in accordance with the requirements of section 6.4.1 of the
Bolster Attachment Code Revision 2 November 2010.

Bolster attachments of the particular design and construction have successfully completed in
excess of 250,000 kilometres on a single vehicle. Details of this reference vehicle are recorded in
the above job/project file.

Date of expiry of this certificate:

Signed..... Date.....

HVEL/HVML Certifier ID.....

*Schedule 4: inserted, on 1 October 2011, by clause 3.1 of Land Transport Rule: Heavy Vehicles
Amendment (No 2) 2011.*

Schedule 4, clause 2.8: amended, on 1 April 2021, by clause 10.6(1) of Land Transport Rule: Agency to Director (Consequential Changes) Amendment 2021.

Schedule 4, clause 6.4.1: amended, on 1 April 2021, by clause 10.6(2) of Land Transport Rule: Agency to Director (Consequential Changes) Amendment 2021.