

HPMV 23m truck and long trailer with steering axle

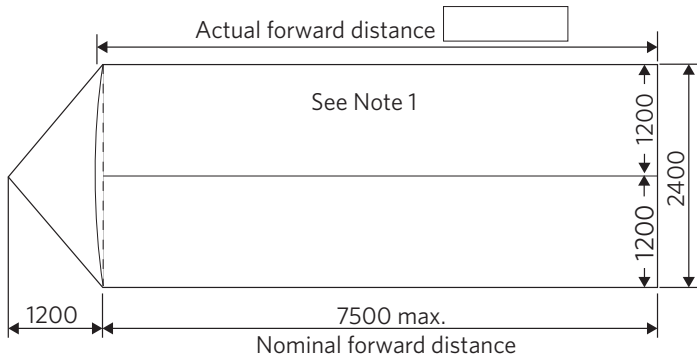
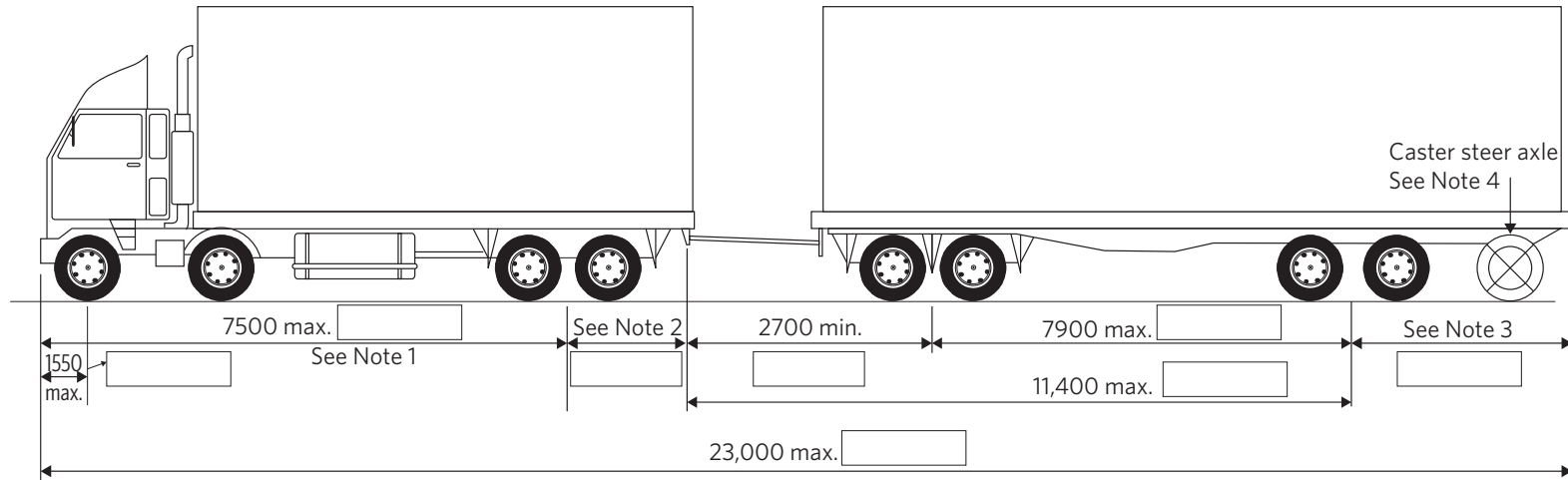

- Note 1** The nominal forward distance is measured from the rear axis to two points at 1200mm off the vehicle centreline. The front of the vehicle must lie within the bound of a symmetric triangle based on the two points with a height of 1200mm as illustrated in the diagram.
- Note 2** Minimum of 1750mm and maximum of 45% of wheelbase.
- Note 3** Maximum rear overhang is the lesser of 4000mm or 70% of the trailer wheelbase.
- Note 4** The rear trailer axle must be a steering axle that must be steering below 40 km/h and must be locked above 60 km/h. It must be capable of turning in both directions through an angle of at least 15 degrees.

The information requested is required to confirm that the vehicle meets the dimension thresholds provided in Waka Kotahi NZ Transport Agency-approved proforma designs for high productivity motor vehicles and to support an application for a High Productivity Motor Vehicle Permit under the Land Transport Rule: Vehicle Dimensions and Mass 2016.

Waka Kotahi (and its agents) will hold, store, use and disclose any personal information collected on this form in accordance with the Privacy Act and the Land Transport Act.

You're entitled to access, and request the correction of, any readily retrievable personal information held about you by Waka Kotahi. You can do so by writing to us at Private Bag 11777, Palmerston North 4442 or by emailing: info@nzta.govt.nz

This section to be completed for entry certification or VIN applications only

Truck/ tractor	Plate number	VIN/chassis number	Make	Model	Year
	<input type="text"/>	<input type="text"/>	<input type="text"/>	<input type="text"/>	<input type="text"/>
Trailer 1	Plate number	VIN/chassis number	Make	Model	Year
	<input type="text"/>	<input type="text"/>	<input type="text"/>	<input type="text"/>	<input type="text"/>

Name of heavy vehicle specialist certifier	Signature of heavy vehicle specialist certifier	Date
<input type="text"/>	<input type="text"/>	<input type="text"/>

I state that, to the best of my knowledge and belief, all the information given for this application is true and correct.
Warning: It is an offence under the Land Transport Act 1998 to provide information that is known to be false or misleading.