



Heritage Significance Assessment:

Beaumont Bridge Clutha, Otago



Heritage Significance Assessment:

Beaumont Bridge

Clutha, Otago

Prepared By



Chessa Stevens
Senior Heritage Consultant

Opus International Consultants Ltd
Dunedin Office
Opus House, 197 Rattray Street
Private Bag 1913, Dunedin 9054
New Zealand

Reviewed By

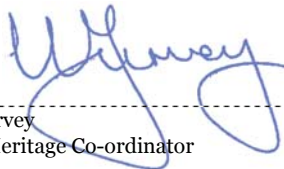

Wendy Turvey
National Heritage Co-ordinator

Telephone: +64 3 471 5500
Facsimile: +64 3 474 8995

Date: 6 October 2016
Reference: 6-CT010.00
Status: Final

Contents

Executive Summary	1
1 Introduction.....	2
1.1 Purpose of this Heritage Assessment.....	2
1.2 Ownership Details	2
1.3 Heritage Status	2
1.4 Information Used to Prepare this Assessment.....	2
1.5 Constraints and Limitations.....	3
1.6 Nomenclature	3
2 History of the Site and Structure	4
2.1 The Site	4
2.2 The Structure	22
2.3 Persons and Groups Associated with the Building.....	35
2.4 Archaeological Sites.....	38
3 Assessment of Heritage Significance	39
3.1 Methodology for Assessing Cultural Heritage Significance	39
3.2 Assessment of Cultural Heritage Significance.....	42
3.3 Methodology for Assessing Fabric Significance	48
3.4 Assessment of Fabric Significance	49
3.5 Statement of Significance.....	50
4 Future Use Considerations.....	51
4.1 Statutory Requirements	51
4.2 Non-Statutory Requirements.....	53
5 Conclusion and Recommendations	55
Bibliography & References	56
Appendix 1	60
Appendix 2	61

Table of Figures

Figure 1: Map showing location of Beaumont (in black) within wider geographic area.....	4
Figure 2: Map showing the location of Beaumont Bridge in relation to key roads and waterways.....	5
Figure 3: Aerial photo showing location of Beaumont Bridge in relation to the Beaumont Township.	6
Figure 4: Beaumont township showing the school in the background, date unknown.	9
Figure 5: Punt crossing the Clutha River at Beaumont carrying a Cobb and Co horse drawn coach c.1870.	10
Figure 6: Punt crossing the Clutha River at Beaumont, date unknown.	10
Figure 7: The Bridge Hotel, Beaumont, photographed c.1890s.....	11
Figure 8: Block III Beaumont District (SO 146) prepared by George Mackenzie, 1871.	12
Figure 9: Plan of Town of Dunkeld (SO 14210) prepared by C.W. Adams, district surveyor, May 1876.	13
Figure 10: Scene at the Beaumont, Molyneux River c.1890s	16
Figure 11: Golden Gravel dredge being launched at Beaumont, 1900.....	18
Figure 12: pontoons of the Golden Gravel Dredging Co at their launching at Beaumont, c.1900. ...	18
Figure 13: Beaumont Railway Station 1915.....	19
Figure 14: Beaumont Race Meeting, 1915. The rugs are spread over the tyres as sun protection. ..	20
Figure 15: Race Day at Beaumont, 1915.	20
Figure 16: Beaumont township c.1920s with the station to the right.	20
Figure 17: Forestry Camp at Tramway near Beaumont, 1920s.	21
Figure 18: Beaumont from the northwest as photographed by Whites Aviation, 1955.	21
Figure 19: Beaumont Hotel during the 2014 motorcycle rally.	22
Figure 20: General Elevation of the Beaumont Bridge, 1887.	23
Figure 21: Plans, sections and elevations of the 58ft 6in lattice girders of Beaumont Bridge.	24
Figure 22: Details of the 58ft 6in lattice girders of Beaumont Bridge.	24
Figure 23: Beaumont Bridge in 1887, thought to be around the time of its opening.....	27
Figure 24: Beaumont Bridge in 1887 shortly after completion.....	28
Figure 25: Beaumont Bridge c.1890. The Bridge Hotel is visible in the background.	28
Figure 26: Beaumont c.1890s showing a horse drawn carriage about to cross the bridge on the left, departing from the Bridge Hotel on the right.....	29
Figure 27: Bridge Hotel with vehicles parked outside, 1918.	30
Figure 28: Beaumont Bridge viewed from south.....	33
Figure 29: South elevation of west abutment.	33
Figure 30: North elevation of west abutment.....	33
Figure 31: Concrete pier.....	34
Figure 32: Lattice girder behind scaffold.....	34
Figure 33: Intersection between small and large lattice girders.....	34
Figure 34: Bridge deck looking west.	34
Figure 35: Understructure of the bridge showing king post trusses strengthening transoms and cross bracing below timber deck.	34
Figure 36: Recent repair of wrought iron bottom chord.....	34
Figure 37: Timber bearers on wrought iron transom.....	35
Figure 38: Timber bearers and edge of timber decking.	35
Figure 39: William Blair, photographed by Burton Bros, date unknown.....	35
Figure 40: John Blackett, photographed by Wrigglesworth & Binns Wellington, August 1891.....	36
Figure 41: Train crossing the Waiteti Viaduct c.1888-90.....	38

Figure 42: Map showing location of NZAA registered archaeological sites within the vicinity of the Beaumont Bridge. 38

Figure 43: Iron Bridge, Lyell. 45

Figure 44: Taramakau Road and Rail Bridge, SH6. 46

Figure 45: Bridge 135 across the Taieri River on Hyde-Macraes Rd.47

Table of Tables

Table 1: Cultural Heritage Significance of Beaumont Bridge..... 49

Executive Summary

Opus International Consultants Limited (Opus) has been commissioned by the NZ Transport Agency to prepare a Heritage Significance Assessment for the Beaumont Bridge, State Highway 8 (SH8), Clutha District. This Assessment will form part of a Detailed Business Case (DBC) that assesses the existing bridge and identifies options for replacement. It is intended to provide insights regarding the history and development of both the Beaumont Bridge and local Beaumont community, and identify and assess their cultural heritage values.

Opened for use in 1887, the Beaumont Bridge consists of three wrought iron truss spans supported on concrete piers. It was the first of four iron truss bridges made entirely from ironwork assembled in New Zealand. The bridge now forms part of SH8 through Central Otago. It is listed as a historic structure in Clutha District Council's Register of Heritage Buildings, item no. H61; but is not listed with Heritage New Zealand Pouhere Taonga.

Erected in the location of a punt that formed part of a vital access route into the Upper Clutha, in place of an earlier bridge that had washed away, the Beaumont Bridge has exceptional historic value that is intrinsically tied to the development of the Beaumont settlement. This historic value is heightened by connections to prominent Public Works Department engineers and contractors who were influential across the country.

While the structure is simple, it is well executed, and retains much of its original fabric. Where additions or repairs have been made, these have been carried out with sympathy to the original design, and have become an important part of the extant structure which. At 130 years old, and believed to be the oldest road bridge of its kind remaining in New Zealand, the Beaumont Bridge is a vital contributor to our national engineering history; and has the potential, through further investigation and interpretive material, to be a source of information for research and public education.

Based on this assessment, it has been concluded that the Beaumont Bridge has high aesthetic and cultural value, and exceptional historic, contextual, technological, scientific and archaeological value; and the settlement of Beaumont has exceptional cultural, archaeological, historic and social value.

Based on the likelihood that the Beaumont Bridge will be recommended for replacement as part of the DBC, the following recommendations are made:

- the Beaumont Bridge should be retained;
- a new use should be found for the Beaumont Bridge;
- this new use should take advantage of existing opportunities such as cycle trails;
- repair works necessary to make the bridge suitable for the selected alternative use should be carried out;
- replacement bridge options should consider the heritage significance of both the existing bridge and the Beaumont settlement;
- a Conservation Management Plan for the Beaumont Bridge should be prepared;
- an Archaeological Assessment for the Beaumont Bridge and the wider area to be affected by works to repair and/or replace the bridge.

1 Introduction

1.1 Purpose of this Heritage Assessment

Opus International Consultants Limited (Opus) has been commissioned by the NZ Transport Agency to prepare a Heritage Significance Assessment for the Beaumont Bridge, State Highway 8 (SH8), Clutha District.

Although the Beaumont Bridge does not present an immediate public safety risk, the NZ Transport Agency is unable to retain confidence in the long term serviceability of the structure. Therefore, a Detailed Business Case (DBC) that assesses the existing bridge and identifies options for replacement is to be developed. This Heritage Significance Assessment has been prepared as part of the DBC to give insights regarding the history and development of both the Beaumont Bridge and local Beaumont community, and identify and assess their cultural heritage values.

1.2 Ownership Details

The Beaumont Bridge is currently administered by the NZ Transport Agency.

1.3 Heritage Status

The Beaumont Bridge is scheduled as a historic structure in Clutha District Council's Register of Heritage Buildings, item no. H61.

The Beaumont Bridge is recognised with an IPENZ Heritage Record, administered by the IPENZ Engineering Heritage Board.¹

The Beaumont Bridge is not on the New Zealand Heritage List maintained by Heritage New Zealand Pouhere Taonga (HNZPT).

1.4 Information Used to Prepare this Assessment

1.4.1 Site Inspection

An inspection of the bridge and site was undertaken by conservation architect Chessa Stevens on 1 September 2016 for the purposes of assessing heritage significance and making a photographic record.

1.4.2 Documentation

In addition to those texts listed in the Bibliography, the following documents have been used to inform this Heritage Assessment:

- *SH8 Beaumont Bridge HPMV Strengthening* PowerPoint presentation prepared by Opus International Consultants, 2015;

¹ The Record is a means of capturing information regarding items of engineering heritage interest. Items may be elevated to the Register by IPENZ where they are considered to have "outstanding or special heritage significance". IPENZ (nd) www.ipenz.org.nz/heritage/

- *SH8 Beaumont Bridge Phase 3 Strengthening* drawings prepared by Opus International Consultants for NZTA, 2015;
- *Contract for Superstructure of the Beaumont Bridge* including plan and elevation drawings and specification, PWD 12762, Archives New Zealand Ref W5 268;
- title and survey information available through Quickmap.

1.5 Constraints and Limitations

The following constraints should be noted:

- Only the documents listed in the Bibliography and 1.4.2 above have been consulted in preparing this Heritage Significance Assessment.
- This Heritage Significance Assessment does not comprise a fabric condition assessment. Only a visual observation of the condition of bridge was undertaken. No invasive testing or analytical investigation has been carried out for the purpose of preparing this Assessment. Information gathered during regular bridge inspections has been used as a reference.
- This Heritage Significance Assessment does not comprise a structural or safety assessment, or contain any kind of engineering advice.
- While this Heritage Significance Assessment considers archaeological values it does not comprise an Archaeological Assessment. This can only be prepared by an appropriately qualified archaeologist.
- Ongoing use or adaptive reuse of the bridge are not discussed at length in this Heritage Significance Assessment. It is understood that the DBC will consider removing vehicle traffic from the bridge and adapting it as a pedestrian and cycleway, and this is discussed in the Recommendations.
- Public engagement will be carried out as part of the DBC. No consultation with stakeholders or affected parties will be carried out as part of preparing the Heritage Significance Assessment.
- This Heritage Significance Assessment does not present the views or history of tangata whenua regarding the cultural significance of the place. These are statements that only tangata whenua can make.
- This Heritage Significance Assessment will not be used as part of any consent or statutory authority application.

1.6 Nomenclature

Many of the places and structures referred to in this Assessment have been known by more than one name, as indicated below. The names given on the left are the names that are used throughout this Assessment.

Beaumont (township)	Dunkeld, Beaumont Bridge
Clutha River	Molyneux River, The Molyneux

The Maori name for the Clutha River, from its source to the sea, is Mata-au.²

² Loosely translating to mean “surface current” McLintock (1966) www.teara.govt.nz

2 History of the Site and Structure

2.1 The Site

2.1.1 Description of the Site

Beaumont is a small rural town located on the banks of the Clutha River in Otago, approximately 75 km west of Dunedin (Figure 1). The town consists of a small number of residential dwellings on large sections, and a pub.

The Beaumont Bridge spans the Clutha River at the north end of the town, connecting the two sides of the settlement (Figure 3). The bridge forms part of State Highway 8 which runs in a loop through the Mackenzie Basin and Central Otago, connecting with State Highway 1 at both ends. The road connects Beaumont with the larger towns of Lawrence to the southeast and Roxburgh to the northwest.



Figure 1: Map showing location of Beaumont (in black) within wider geographic area.

Source: www.nztourmaps.com



Figure 2: Map showing the location of Beaumont Bridge in relation to key roads and waterways.
 Source: nzfishing.com



Figure 3: Aerial photo showing location of Beaumont Bridge in relation to the Beaumont Township.

Source: Google Earth

2.1.2 History of the Site

Archaeological research suggests that Maori presence in central and southern Otago dates back at least as far as the 13th century, and that the area was an important focus of activity during the Archaic (or moa hunting) period.³ Summarised histories prepared by community groups and local authorities⁴ refer to the seasonal explorations and establishment of river trails through inland Otago by early Maori; and particularly to mahinga kai trails along the Mata-au (Clutha River).

³ Brooks et al (2010) p9

⁴ Mighty Clutha (2009) mightyclutha.blogspot.co.nz; Save the Clutha (2009) savetheclutha.blogspot.co.nz; Hands off Beaumont (2009) handsoffbeaumont.blogspot.co.nz; Dunedin Family History Group (nd) www.dunedinfamilyhistory.co.nz; Central Otago District Council (2014) p13

According to the Central Otago District Council:

The Mata-au [Clutha River] marked the boundary between Ngāi Tahu and Ngāti Mamoe. Ngāi Tahu held the mana over the land north of the Mata-au and Ngāti Mamoe south. Eventually the division was overcome with union between the two tribes. For Ngāi Tahu the Mata-au was part of a mahinga kai trail that led inland used by Otakou hapu including Ngāti Kuri, Ngāti Ruahikihiki, Ngāti Huirapa and Ngāi Tuahuriri.⁵

Archaeological discoveries of stone quarries, as well as tools, sharpening stones, feathers and bones indicate that these trails were also used to collect materials such as argillite, transport pounamu to and from the west coast, and hunt Moa. During these explorations, campsites or seasonal settlements were established; and the remains of such sites have been found near Beaumont.⁶ These were recognised from the earliest days of European Settlement, with one of the first stations to be established being named Oven Hills Station, referring to the high concentration of Maori ovens on the land.⁷ Urupa (burial places), tauranga waka (landing places), and battlegrounds have also been found along the Mata-au.⁸

According to Brooks et al (2010):

Very little is known of the use of the interior of southern New Zealand after the extinction of the moa [14th century] and it is possible that Central Otago was more or less abandoned until shortly before European contact.⁹

The coastline of Otago was recorded by Captain James Cook during his navigation of New Zealand aboard *Endeavour* in 1770. Molineux's Harbour – the mouth of the dual branches of the Clutha River (Figure 2) – was named for Robert Molineux, the *Endeavour's* sailing master. However, Cook did not land in the area. The first contact between local Maori and Europeans is understood to have come sixty years later, when the American sea captain and explorer Benjamin Morrell visited Molineux's Harbour in 1830.¹⁰ In his disputed memoir, *A Narrative of Four Voyages*, Morrell refers to the harbour as “Molyneux” Harbour, and describes visiting a local Maori settlement inland from the harbour on the banks of the river.¹¹

It is by combination of these events that the Clutha River and wider area became known as “the Molyneux” as McLintock (1966) explains:

The early whalers and settlers of South Otago called the [Clutha] river and the district the Molyneux, and the name survived well into the gold mining era. It has often been stated that Cook gave the name Molyneux to the river, but this is incorrect for he never saw it ... The correct name is the Clutha, first suggested in 1846 when the Scottish emigrants were preparing to settle in Otago.¹²

Clutha is derived from Cluaidh, the Scots Gaelic name for the River Clyde in Glasgow, Scotland.¹³

⁵ Central Otago District Council (2014) p13

⁶ NZAA Recorded Site G44/3; Brooks et al (2010) p9

⁷ Webster (1948) p8

⁸ Central Otago District Council (2014) p13

⁹ Brooks et al (2010) p9

¹⁰ Waite (1940) p4-6

¹¹ *A Narrative of Four Voyages* details the construction of Maori huts: “they are seldom more than five feet in height. They are framed of young trees and thatched with long, coarse grass. Their household furniture consists of a few small bags, in which they deposit their fishing gear and other trifles”. Waite (1940) p6

¹² McLintock (1966) www.teara.govt.nz

¹³ Central Otago District Council (2014) p13

In 1853, the 23-year-old Nathanael Chalmers was the first European to venture up the Clutha River. Chalmers had first arrived in Otago in 1849 with his brother G. A. Chalmers; and, after a brief attempt at gold mining in Australia, returned to Invercargill from where he assisted in driving a mob of cattle overland to Dunedin. On this journey he met the Maori chief Reko, who agreed to take Chalmers inland to the north in search of good farming country. Travelling on foot, he was guided by Reko and another Maori chief, Kaikoura, from Tukurau, southwest of Gore, up to Lake Wakatipu and beyond. When Chalmers became ill with dysentery Reko and Kaikoura constructed a flax raft or mokihi, and travelled down the Clutha River back to European company, passing through the sites of later European settlement including Beaumont.¹⁴

Explorer-surveyor John Turnbull Thompson was appointed to the position of chief surveyor of Otago following his arrival in New Zealand in 1856. Up until this time, only the coast of Otago had been mapped.

... Thomson accepted the challenge of exploring and mapping this huge territory... During 1857 and early 1858 he carried out his marathon reconnaissance survey of Otago, covering the whole province on horseback in a series of sweeps that took him as far west as the Waiau River and as far north as Mt Cook ... As a result of his survey the first map of the interior of Otago was published in 1860.¹⁵

In the same year as Thomson began his surveys, European run holders began to explore the Upper Clutha valley in search of land suitable for establishing new sheep runs. Several large stations were soon established along the Clutha River, including: Bellamy Station, the starting point for run pioneers heading further into the Upper Clutha; Beaumont Station of over 30,000 acres on the eastern side of the river, named for Beaumont Burn on its southern boundary; Dunkeld Station, across the river from Beaumont Station; and Moa Flat Station of over 71,000 acres on the western side of the river.¹⁶

In conducting his survey, Thomson named several areas after places in his home country of Scotland.¹⁷ Beaumont township, which was established at the location of a natural river crossing on the borders of Bellamy, Beaumont and Dunkeld Stations, was originally named by Thomson as “Dunkeld”, a Gaelic name from Perthshire.¹⁸ However, the Beaumont Burn quickly became familiar to local residents and travellers, who inevitably began to refer to the area as “the Beaumont”.¹⁹

Following the discovery of gold at nearby Gabriel's Gully in May 1860, miners and prospectors began exploring the lower and upper Clutha en masse, and the river crossing at Beaumont quickly became vital. An account of Beaumont's history given by the website of the Beaumont Residents Group states that the first Beaumont punts operated from 1860;²⁰ however, an article in the Otago Daily Times in 1864 states that various private applications to put punts in place at Beaumont and

¹⁴ Webster (1940) p11; Frazer (updated 2013) www.teara.govt.nz; Save the Clutha (2009) savetheclutha.blogspot.co.nz

¹⁵ Hall-Jones (updated 2014) www.teara.govt.nz

¹⁶ Webster (1948) pp13-17. According to Webster, Moa Flat was owned by G. A. Chalmers, who brought sheep in from Australia by ship, landing them at Port Molyneux and driving them “up the roadless country” to the station. When Chalmers got into financial difficulty he borrowed from Joseph Clarke, a Tasmanian farm manager and shareholder in the Colonial Bank. Clarke took possession of the station when G. A. Chalmers failed to meet his financial commitments, and dispatched John Fry Kitching from Tasmania to manage the station. A biography of Clarke is given at adb.anu.edu.au/biography/clarke-joseph-3342. Kitching went on to be heavily involved in the development of Beaumont, as explained further in this section.

¹⁷ Hall-Jones (updated 2014) www.teara.govt.nz

¹⁸ Hands off Beaumont (2009) handsoffbeaumont.blogspot.co.nz. The name “Dunkeld” means “Fort of the Caledonians”.

¹⁹ Hands off Beaumont (2009) handsoffbeaumont.blogspot.co.nz. Beaumont is French for “beautiful mountain”. How the Beaumont Burn came to be named has not been discovered in the course of this research.

²⁰ Hands off Beaumont (2009) handsoffbeaumont.blogspot.co.nz

Teviot had been turned down by the Government on the grounds that they were about to undertake the works.²¹ It is evident that a punt was operating by 1868, when the lessee, Mr Botwell, requested that the approaches to the punt be repaired.²²

From 1863, Beaumont was also the head of navigation for steam-powered trading vessels travelling up the river from Balclutha.²³ In this same year, gold dredging on the river was pioneered near the settlement as alluvial gold became scarce;²⁴ though it was not until the 1890s that dredging became a popular method of sourcing gold.

By 1870, there were three hotels catering for travellers in the settlement – the Crookston, the Beaumont Ferry and the Duke of Edinburgh;²⁵ the Beaumont Racecourse was opened; and the last town sections were put up for sale by auction at a cost of £5.²⁶ The earliest survey map of the area that has been sourced in preparing this assessment is dated 1871 (Figure 8). Development continued throughout the 1870s, with the opening of a church and the school.



Figure 4: Beaumont township showing the school in the background, date unknown.

The school house is partially concealed behind the large tree on the right. This building remains extant today, though has been considerably modified. The building on the corner also remains extant though considerably modified. The neighbouring house has been demolished.

Source: bp.blogspot.com

Around this time, a traveller through Beaumont observed:

that several new buildings or improvements were in the course of erection. Mr. Cowap is having a commodious hotel built on the site of the old house, and I have no doubt the establishment will prove highly convenient to all travellers. My consternation may be imagined when I was informed that there was very little chance of my getting across [the river] as the high wind rendered the passage dangerous; however ... I was safely ferried over the broad bosom of the Molyneux.²⁷

As this passage implies, the Beaumont punt was vulnerable to weather conditions and could be unreliable, leading to calls for the construction of a bridge.

²¹ Otago Daily Times, 20 October 1864

²² Bruce Herald, 5 February 1868

²³ Hands off Beaumont (2009)handsoffbeaumont.blogspot.co.nz

²⁴ Hands off Beaumont (2009)handsoffbeaumont.blogspot.co.nz

²⁵ Hands off Beaumont (2009)handsoffbeaumont.blogspot.co.nz.html

²⁶ Otago Daily Times, 24 February 1870; Tuapeka Times, 23 June 1870

²⁷ Tuapeka Times, 27 March 1869

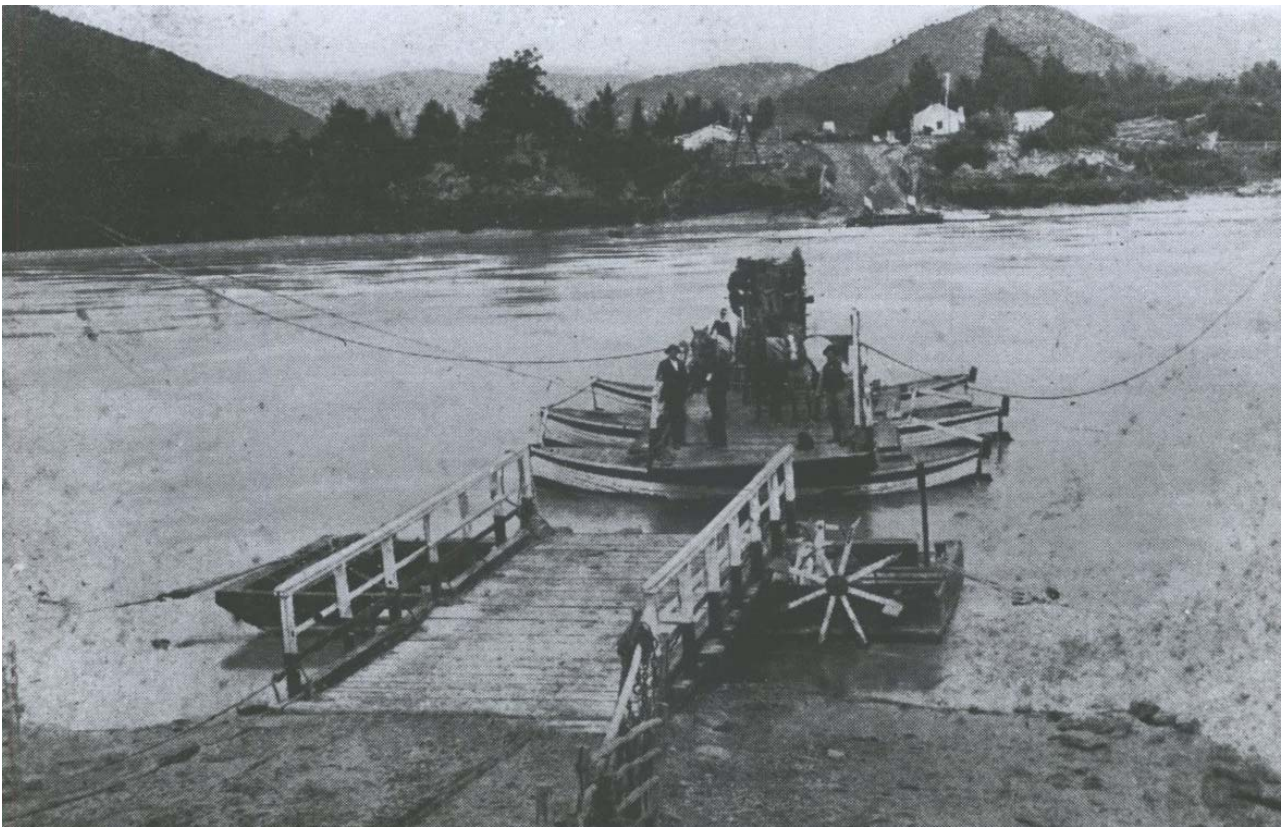

Figure 5: Punt crossing the Clutha River at Beaumont carrying a Cobb and Co horse drawn coach c.1870.
Source: Hocken Collection Asset ID 6261



Figure 6: Punt crossing the Clutha River at Beaumont, date unknown.
Source: bp.blogspot.com

The first bridge at Beaumont was privately commissioned by William Hayes in 1873, and constructed by David McDonald.²⁸ Supported by stone piers and abutments set onto rock, this bridge had six spans constructed in timber: two of 16 metres at each end, being “ordinary undertrussed girders”; and two of 30 metres in the centre, “built on the lattice girder principle”. The cost of construction was approximately £7,000.²⁹

While construction commenced at pace, significant delays were caused when the wire rope used to convey the blocks of stone from the river banks to the piers snapped only a few months into the project.³⁰ However, McDonald executed the installation of the 30 metre-long bridge girders without incident; and the bridge was opened to foot traffic in September 1874.³¹ While it was not heralded for its architectural beauty, the bridge was evaluated by the public as an imposing structure with “a look of strength and durability”.³²

The construction of roads in the area was slow, and McDonald and his team were forced to build their own tracks to get materials to the bridge site. Roads connecting with the bridge were surveyed in 1874, and construction then began on the approaches. However, these remained incomplete when the bridge was opened to pedestrians; and it was not until November 1874 that the eastern approach, which had to be built up by approximately 10 metres, was passable for traffic.³³

It was expected that traffic on the road through Beaumont would be substantially increased as a result of the erection of the bridge; however, the slow construction of adequate roads servicing the area restricted use of the route, and therefore the bridge. The comparatively low cost of the punt, and the lack of facilities such as a hotel and paddocks for resting animals at the site, also contributed to the poor uptake in use of the bridge.³⁴

In 1875 Hayes placed the bridge on the market; and, in 1876, it was sold to the New Zealand Loan Company who on-sold it to J. F. Kitching.³⁵ Kitching also purchased the punt. With his ownership over both methods of river crossing secured, Kitching increased the bridge tolls. This caused widespread complaint; however, Kitching refused to lower his prices, stating that the bridge being private property and he was entitled to charge as he pleased.³⁶ Kitching also constructed a new hotel at the bridge – the Bridge Hotel – along with his own stables and outbuildings.³⁷



Figure 7: The Bridge Hotel, Beaumont, photographed c.1890s.

Source: Hocken Collections Asset ID 6253

²⁸ Evening Star, 20 May 1873; Bruce Herald, 17 June 1873; Bruce Herald, 13 October 1874

²⁹ Otago Daily Times, 11 December 1874

³⁰ Tuapeka Times, 21 August 1873

³¹ Tuapeka Times, 27 June 1874; Bruce Herald, 7 July 1874; Tuapeka Times, 23 September 1874

³² Letter to the Editor, Tuapeka Times, 28 November 1874; Otago Daily Times, 11 December 1874

³³ Tuapeka Times, 19 August 1874; Tuapeka Times, 4 November 1874; Tuapeka Times, 25 November 1874; Tuapeka Times, 28 November 1874

³⁴ Bruce Herald, 12 October 1875; Bruce Herald, 14 March 1876

³⁵ Bruce Herald, 14 March 1876; Tuapeka Times, 1 November 1876. For further discussion regarding J. F. Kitching and his arrival in the area, refer Footnote 16.

³⁶ Tuapeka Times, 6 January 1877; Tuapeka Times, 10 March 1877

³⁷ Tuapeka Times, 30 November 1878



Figure 8: Block III Beaumont District (SO 146) prepared by George Mackenzie, 1871.
Source: Quickmap

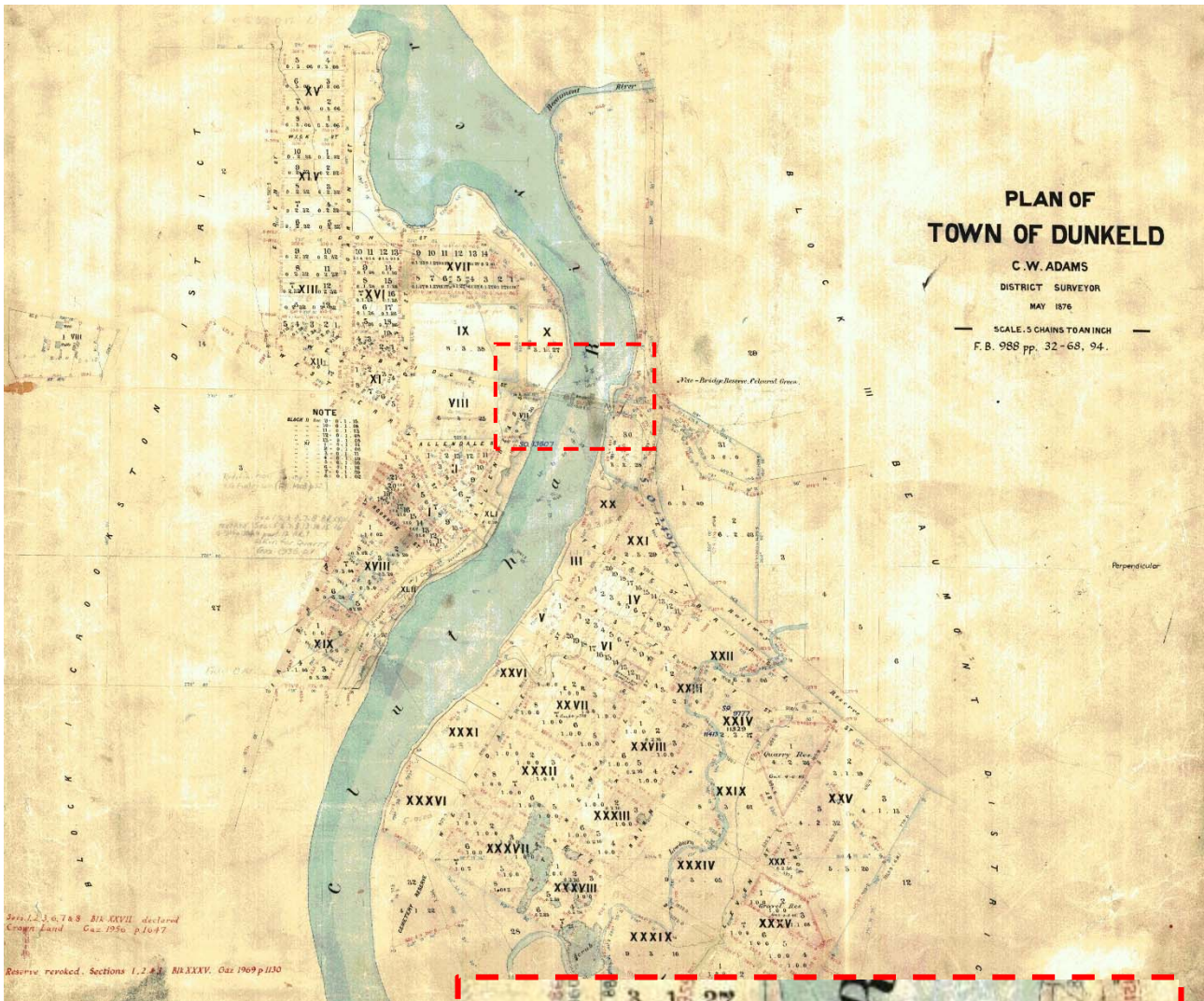

Figure 9: Plan of Town of Dunkeld (SO 14210) prepared by C.W. Adams, district surveyor, May 1876.
Source: Quickmap



Towards the end of 1877 the Tuapeka County Council began investigating the purchase of the bridge; and the Government agreed to contribute the sum of £5,000 to the cost. While there was some dispute over the state of the bridge – particularly the extent of rot in the main timbers – and Kitching made it clear that he would not accept an offer of £5,000, the Council pursued the purchase. This had the general support of the community who were in favour of removing the tolls opening the bridge for free traffic.³⁸

Before any purchase could be agreed, however, the Clutha River experienced severe flooding. On 27 September 1878, the water was reported as being right up to the roadway of the bridge, which was “shaking in a most dangerous manner”.³⁹ On 28 September, the Tuapeka Times reported that one of the piers and the abutments on the Lawrence side of the bridge had been carried away, and one of the “principal beams” of the bridge was cracked.⁴⁰ Floodwaters subsided briefly, but began to rise again on the morning of 30 September; and the centre of the bridge was washed away that afternoon.⁴¹ The Evening Star described the event:

Mr Jacob Davidson, with a buggy, was the last person to cross, and just as he landed on the Lawrence side the bridge went away in two pieces. Both sections of the superstructure sailed away down the river, locking like two large punts. One stone pier was carried away, and there are two apparently sound... The telegraph line crossing the river is broken and cannot be repaired, as there is no boat available, and it is questionable if one could live in such a torrent... Beaumont town is partly under water. Some of the residents cleared out last night. No communication can be held verbally with the opposite bank, owing to the high wind.⁴²

Several other bridges over the Clutha were also washed away in the flood.

Under the instruction of the County Engineer, work to construct a free punt across the river at the site of the bridge was commenced as a temporary measure while the re-erection of the bridge was discussed. However, Kitching, with his own punt back in operation, quickly asserted his right to both banks of the river for three miles either side of the bridge site. The Council conceded, and ceased construction of the free punt, while Kitching once again began to charge exorbitant tolls.⁴³

With the loss of the bridge, and the high cost of the punt, traffic between Dunedin and Alexandra, Clyde, Cromwell, Cardrona, and other goldfields in the area was diverted to other roads, and local businesses in Beaumont began to suffer.⁴⁴ At a public meeting in March 1879, the Council agreed to offer Kitching the sum of £3,000 for purchase of the bridge site including the punt;⁴⁵ however, negotiations between the two parties failed to result in an agreement.

In late 1879, the community petitioned the Government to re-erect the bridge, or to force the Council to do so.⁴⁶ In response, the Parliamentary Public Petitions Committee stated that the Government had already agreed to contribute £5,000 for the purchase of the previous bridge, £3,000 of which had already been advanced to the Council for this purpose. Further, the Public Petitions Committee noted, the £3,000 had not yet been used to make the purchase, and they

³⁸ Tuapeka Times, 2 March 1878; Otago Daily Times, 13 May 1878; Tuapeka Times, 12 June 1878

³⁹ Bruce Herald, 27 September 1878; Evening Star, 27 September 1878

⁴⁰ Tuapeka Times, 28 September 1878

⁴¹ Oamaru Mail, 30 September 1878

⁴² Evening Star, 30 September 1878

⁴³ Tuapeka Times, 30 November 1878

⁴⁴ Tuapeka Times, 25 April 1872

⁴⁵ Tuapeka Times, 31 March 1880

⁴⁶ Tuapeka Times, 8 October 1879

recommended the Government take immediate action to recover the money.⁴⁷ Simultaneously, the New Zealand Loan and Mercantile Agency Company began demanding payment of the agreed £3,000 with interest on Kitching's behalf.⁴⁸

The Tuapeka County Council finally paid to Kitching, with interest, the sum of £3,000 to purchase the land associated with the former bridge and existing punt in January 1880. The County Engineer, William Smaill, estimated the cost of constructing a new bridge in the same location at just over £7,000. The Council resolved to call for tenders for the construction of a new bridge on the basis that the Government's offer to contribute £2,000 to the cost of construction was secured.⁴⁹ The Council was also faced with the cost of repairing roads and other bridges throughout the district following the floods, and finances were tight.⁵⁰

In February 1880, John McCormick, who had erected two bridges over the Kawarau River and was, at the time, erecting another on the Queenstown Road, made an offer to the Council to construct this bridge in iron imported from England, to plans and specifications prepared by "a competent Engineer".⁵¹ However, his offer was rejected by the Council on the grounds that no plans or specifications were presented to show the style, materials, height or width of the bridge; and his price was too high. This caused considerable debate within the Council, especially as some councillors considered it likely that the Government's offer to contribute a further £2,000 to the cost of the bridge would soon lapse.⁵²

The Government did not withdraw the funds; however, a letter from Public Works Office to the County Council in April 1880 confirmed that they would not enter into any agreement to provide the money unless and until the expenditure of money already advanced had been properly accounted for.⁵³

In May 1880 a second offer to construct the bridge was made to the Council, this time by R. Campbell & Co of Dunedin; and, like McCormick's offer, this was declined.⁵⁴

The Council continued to seek payment of the £2,000 from the Government; and, in June 1880, a deputation was put before the Minister of Public Works. The Minister responded that the Government "would be prepared to pay it as a first progress payment on the Council entering into a contract for the re-erection of the bridge".⁵⁵ Still an agreement between the two parties could not be reached, with many councilors arguing that the County did not have the necessary funds to make its contribution; especially given the high cost of maintaining the roads in the area.⁵⁶ Motions by pro-bridge councilors to call for tenders to construct the bridge were repeatedly lost to those who were against.⁵⁷ Letters were exchanged between the Council, the Department for Public Works, and Treasury; but the Government remained unmoved.⁵⁸ Meanwhile, the punt continued to operate at what many members of the community considered to be an unreasonably high cost.⁵⁹

⁴⁷ Otago Daily Times, 3 December 1879; Tuapeka Times, 13 December 1879; Otago Witness, 13 December 1879

⁴⁸ Tuapeka Times, 13 December 1879

⁴⁹ Tuapeka Times, 17 January 1880

⁵⁰ Tuapeka Times, 17 December 1879

⁵¹ Tuapeka Times, 24 March 1880

⁵² Tuapeka Times, 17 March 1880

⁵³ Tuapeka Times, 10 April 1880

⁵⁴ Tuapeka Times, 15 May 1880

⁵⁵ Tuapeka Times, 9 June 1880

⁵⁶ Tuapeka Times, 10 July 1880

⁵⁷ Tuapeka Times, 12 February 1881; Tuapeka Times, 9 April 1881

⁵⁸ Tuapeka Times, 20 July 1881; Tuapeka Times, 20 July 1881; Tuapeka Times, 19 October 1881; Tuapeka Times, 17 December 1881; Otago Daily Times, 6 March 1882

⁵⁹ Tuapeka Times, 20 July 1881

Finally, the Council was advised to apply for assistance under the newly passed Roads and Bridges Construction Act 1882 for the balance of funds; and, after the Council applied for a much higher sum of £7,000 the Government agreed to contribute £6,000; however, this was also to cover the cost of re-erecting another bridge over the Clutha River at Roxburgh.⁶⁰ Plans and specifications for the Beaumont Bridge, were received by the Tuapeka County Clerk in April 1883; and the first tenders were called for its construction.⁶¹

Construction of the Beaumont Bridge was carried out under two contracts: the first for the piers and abutments; and the second for the superstructure. The first contract commenced in September 1883 and was set down for completion in January 1884; however, for reasons discussed in Section 2.2.1 it was not until mid-1885 that the piers and abutments were complete and construction of the superstructure was able to commence.

During this time, the punt continued to ferry passengers, vehicles, and stock across the river at Beaumont.⁶² In November 1886, it overturned, throwing the punt man, three passengers, and a wagon of goods drawn by four horses, into the river. Men working on the Beaumont Bridge witnessed the accident, and managed to rescue three of the four passengers from downstream. The fourth passenger, a nine year old girl, was unable to be rescued.⁶³ The punt reopened within a few weeks; however, the accident led some to believe that the state of the punt had been neglected by the Council due to the imminent completion of the bridge.⁶⁴

The Beaumont Bridge officially opened in March 1887, by which time the township of Beaumont had a store, butchery, bakery, blacksmith, and post office, in addition to the hotels, church and school.⁶⁵ With the opening of the bridge, the punt was finally closed.⁶⁶ This was a relief to the Council, who, by ruling of the Supreme Court, were held responsible for the punt accident.⁶⁷ To recoup the resulting financial losses, the Council proposed to charge waggoners a toll for crossing the new Beaumont Bridge.⁶⁸ Not surprisingly, this proposal was not viewed favourably, and the matter was later dropped.⁶⁹



Figure 10: Scene at the Beaumont, Molyneux River c.1890s

Note the bridge in the foreground (left) and the Bridge Hotel in the background (right).

Source: Otago Daily Times

⁶⁰ Tuapeka Times, 18 April 1883

⁶¹ Tuapeka Times, 25 April 1883

⁶² Tuapeka Times, 9 August 1884

⁶³ Tuapeka Times, 24 November 1886

⁶⁴ Tuapeka Times, 24 November 1886

⁶⁵ Hands off Beaumont (2009)handsoffbeaumont.blogspot.co.nz

⁶⁶ Clutha Leader, 18 March 1887

⁶⁷ Otago Witness, 29 April 1887

⁶⁸ Tuapeka Times, 27 April 1887

⁶⁹ Tuapeka Times, 14 January 1888

Land on either side of the bridge, held in reserve, then became the subject of community debate, with the Land Board resolving to keep some in reserve, with a remainder being surveyed into one acre lots and offered for sale.⁷⁰ The land held back was leased periodically to locals for pastoral purposes.⁷¹

Beaumont boomed in the 1890s with the arrival of steam-powered and then electric-powered gold dredges to the Clutha.⁷² In 1895, a correspondent for the *Tuapeka Times* reported:

The Molyneux and the Beaumont are now attracting the attention of the mining public. The local Co-operative Hydraulic Sluicing Co., whose claim is located a little above the Beaumont bridge, have started the cutting of their headrace. Two parties have contracted for over three-fifths of the entire length... This claim has the reputation of having a very rich run of wash (an old bed or channel of the river) running through it. This channel or riverbed was followed by a party of miners in the sixties till they were bested by water... Two licensed holdings are also applied for, one above the Beaumont bridge and one below, and it now remains only a matter of time when the whole of this hitherto neglected, portion of the river will be taken up for dredging purposes.⁷³

Similar reports continued throughout the late 1890s, as reported in the *Otago Witness*:

The Tuapeka Dredging Company, whose claim is above the Beaumont bridge, are very reticent as to their returns. I was privileged, however, at their last week's wash-up to get; the yield handed to me for my judgment as to weight, and it was heavy, considering the ancient and out-of-date dredge they have to work with. This party, I understand, are negotiating for a new and powerful dredge to supplant their present one, and when this is achieved something phenomenal in the way of returns is expected.⁷⁴

In January of this year [1897] three dredging claims were taken up in the Molyneux River – seven, nine and 12 miles respectively – below Beaumont bridge ... the area of each of the claims is 50 acres, and the total capital proposed to be invested is £19,000.⁷⁵

It has been estimated that approximately 150 gold-dredges were active on the Clutha River during the 1890s.⁷⁶ By the turn of the century the boom had reached its high point, and slowly began to decline; though dredging continued on the Clutha for several decades leading to a second, smaller boom in the 1930s.⁷⁷

⁷⁰ Tuapeka Times, 3 September 1887

⁷¹ Tuapeka Times, 5 September 1896; Evening Star, 31 March 1897; Evening Star, 7 July 1897

⁷² Walrond (nd) www.teara.govt.nz

⁷³ Tuapeka Times, 30 October 1895

⁷⁴ Otago Witness, 30 July 1896

⁷⁵ Otago Witness, 19 August 1897

⁷⁶ Hands off Beaumont (2009) handsoffbeaumont.blogspot.co.nz

⁷⁷ Walrond (nd) www.TeAra.govt.nz

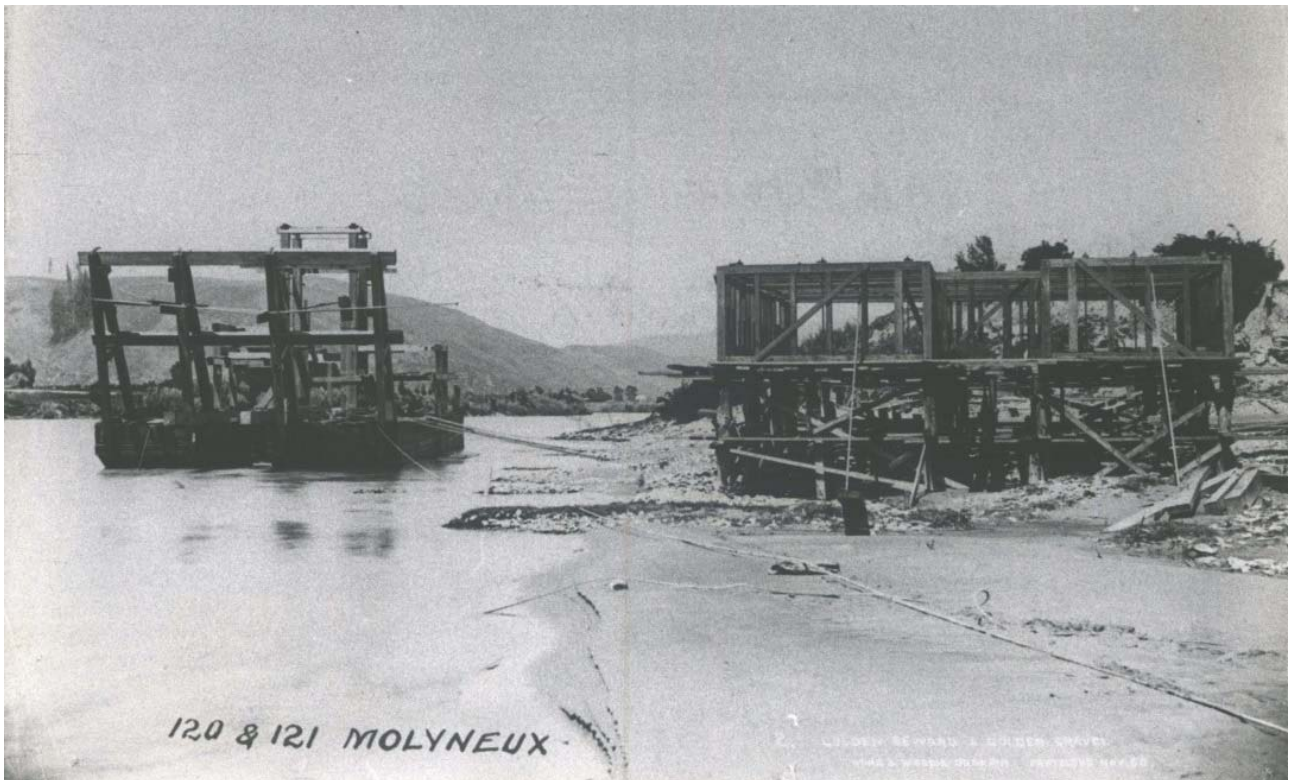

Figure 11: Golden Gravel dredge being launched at Beaumont, 1900.

Source: Hocken Collections Asset ID 6268

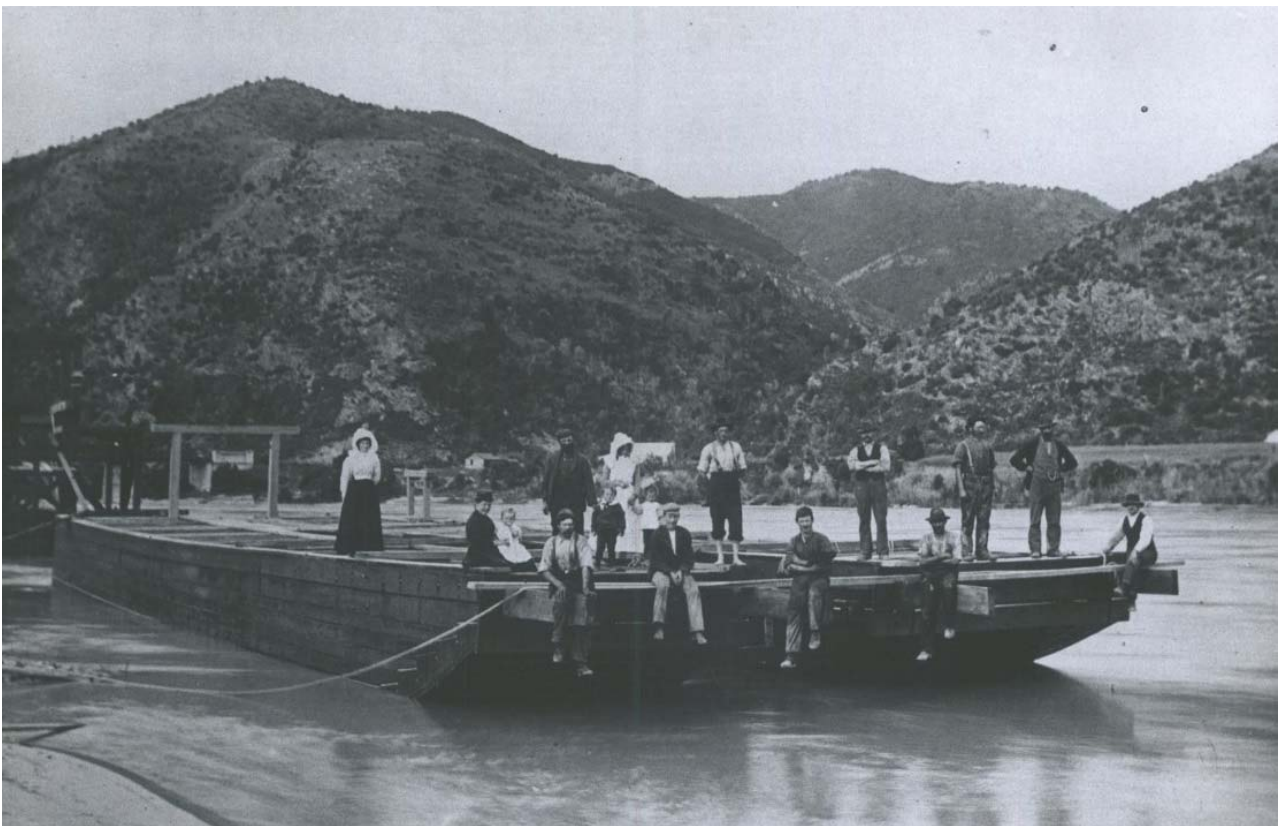

Figure 12: Pontoons of the Golden Gravel Dredging Co at their launching at Beaumont, c.1900.

Source: Hocken Collections Asset ID 6266

In 1905, construction of a long awaited extension of the railway line from Lawrence, through Beaumont to Roxburgh, commenced. It was hoped that, by making access to the Upper Clutha easier, industries other than gold mining and sheep farming would begin to prosper – particularly the industry of fruit growing.⁷⁸ However, construction of the line was slow, taking almost ten years to reach Beaumont.⁷⁹ By this time, the local population had lost all expectation that the line would ever reach Roxburgh; and, instead, began to demand that the main road be made suitable for motor vehicles.⁸⁰ Never-the-less, construction continued and, during the following decade, the population of Beaumont reached its highest point as railway workers and their families took up residence. Beaumont remained the terminus of the branch line until 1925 when the extension to Millers Flat finally opened.⁸¹ The line did not reach Roxburgh until 1928, by which time it was not just fruit growing, but also forestry, that had become established industries in Beaumont.⁸²

These industries saw Beaumont through the Great Depression.⁸³ The Beaumont Racing Club continued to operate;⁸⁴ and a new hotel was constructed to replace the Bridge Hotel shortly before the outbreak of the Second World War.⁸⁵ This hotel remains operational at the time of preparing this Assessment.



Figure 13: Beaumont Railway Station 1915.

Source: Hocken Collection Asset ID 6252

⁷⁸ Otago Witness, 6 December 1905

⁷⁹ Dunedin Family History Group (nd) www.dunedinfamilyhistory.co.nz

⁸⁰ Mt Benger Mail, 21 January 1914

⁸¹ Dunedin Family History Group (nd) www.dunedinfamilyhistory.co.nz

⁸² Hands off Beaumont (2009) handsoffbeaumont.blogspot.co.nz

⁸³ Otago Daily Times, 25 November 1930

⁸⁴ Mt Benger Mail, 3 October 1934

⁸⁵ Dunedin Family History Group (nd) www.dunedinfamilyhistory.co.nz



Figure 14: Beaumont Race Meeting, 1915. The rugs are spread over the tyres as sun protection.
Source: Hocken Collections Asset ID 6256



Figure 15: Race Day at Beaumont, 1915.
Source: Hocken Collections Asset ID 6248



Figure 16: Beaumont township c.1920s with the station to the right.
Source: Hocken Collections Asset ID 6257



Figure 17: Forestry Camp at Tramway near Beaumont, 1920s.

Source: bp.blogspot.com



Figure 18: Beaumont from the northwest as photographed by Whites Aviation, 1955.

The bridge is indicated with the red arrow. Source: ATL WA-39258-F

However, closure of the railway branch line in 1968 signalled the start of a significant decline⁸⁶ that was exacerbated by the rise of large land holdings, changes in the horticultural sector, and closure of the local forestry headquarters. During the 1980s, the Racing Club and the school were officially closed.⁸⁷ The school house remains extant today, though it is evident that it has been considerably modified over the course of its life. The racecourse has been utilised for horticultural purposes.

These factors notwithstanding, an aerial photograph of Beaumont taken in 1955 (Figure 18) indicates that the size of the settlement has changed little since this time. While some homes and farm buildings have been demolished, many remain though may have been extensively modified.

In 1992, the Electricity Corporation of New Zealand (ECNZ) proposed the construction of a dam at Tuapeka Mouth that would flooded 3,000ha of land, including all of Beaumont. Some locals agreed to sell their land; however, others were determined to resist, forming lobby groups including "Hands off Beaumont" to protect the township's "rich history and its attractive and distinctive environment".⁸⁸ Plans for this dam, along with others along the Clutha, were officially abandoned in 2012.⁸⁹

The Beaumont Hotel remains open for meals and accommodation, and hosts the annual Beaumont Motorcycle Rally along with other community events.



Figure 19: Beaumont Hotel during the 2014 motorcycle rally.
Source: www.odt.co.nz

2.2 The Structure

2.2.1 Design & Construction

The Beaumont Bridge comprises four concrete piers and two concrete abutments, supporting a superstructure of wrought iron. No specification for the concrete work has been cited in preparing this Assessment; however, it is evident from site inspection that the concrete consists of aggregate of varying sizes which is likely to be river gravel, with low cement content. All concrete work is finished with a cement render, struck out in lines to resemble stonework.

⁸⁶ Otago Daily Times, 11 January 2014

⁸⁷ Dunedin Family History Group (nd) www.dunedinfamilyhistory.co.nz

⁸⁸ Otago Daily Times, 11 January 2014

⁸⁹ Save the Clutha (2009) savetheclutha.blogspot.co.nz

Five spans make up the bridge — three central spans of 115ft (approximately 35m), and two end spans of 58ft 6in (just under 18m) giving a total length of 462ft (approximately 140.8m).⁹⁰ Each span is made up of two wrought iron lattice girders, formed by connecting top and bottom chords with channel-section and H-section struts crossed at 45 degrees to form a lattice, finished at each end with a vertical post. Larger girders were required for the longer spans, but both sizes of girder were constructed following the same design principles, increasing in weight from the centre of the spans to the ends without altering the spacing of the braces. The specification for the superstructure works called for the large girders to be fastened down on piers 1 and 4, with the other connections to be “furnished with malleable-iron roller-frames and rollers”. The small girders were to be fastened at the abutments and loose on piers 1 and 4.⁹¹

The lattice girders are connected with rolled wrought iron I-section transoms (also referred to as cross-girders) placed on the bottom chord of the lattice at every intersection. These cross-girders are braced with horizontal cross-bracing. Every second transom projects beyond the bottom chord, and is tied back to the top chord with a diagonal brace. The transoms provide support for the timber bearers (also referred to as beams or stringers) to which the timber decking is fixed. The specification required all timber to be matai, totara or kauri, and a minimum of “three quarter heart”. A contemporary report stated that the decking was “of best totara from the Southland mills” and “of the most durable quality”. The breadth of the deck is 14ft (approximately 4.3m) which, at the time, was reported as providing enough room to pass.⁹² The height of the bridge deck above the average river level was specified in the contract drawings as 30ft (just over 9m) in the hopes of ensuring it would not be susceptible to flooding.⁹³

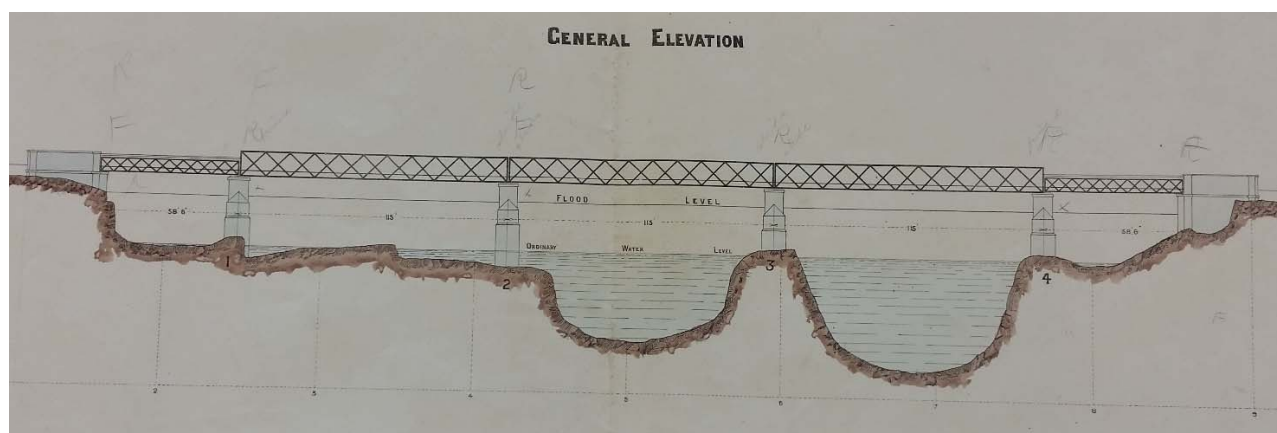

Figure 20: General Elevation of the Beaumont Bridge, 1887.

Note the five spans, the three central spans being larger than the two end spans. The piers were all founded on rock.
Source: PWD 12762, Archives New Zealand Ref W5 268

⁹⁰ Contract for Superstructure of the Beaumont Bridge, PWD 12762, Archives New Zealand Ref W5 268.

⁹¹ Tuapeka Times, 9 March 1887; Contract for Superstructure of the Beaumont Bridge, PWD 12762, Archives New Zealand Ref W5 268.

⁹² Tuapeka Times, 9 March 1887

⁹³ Tuapeka Times, 9 March 1887; Contract for Superstructure of the Beaumont Bridge, PWD 12762, Archives New Zealand Ref W5 268.

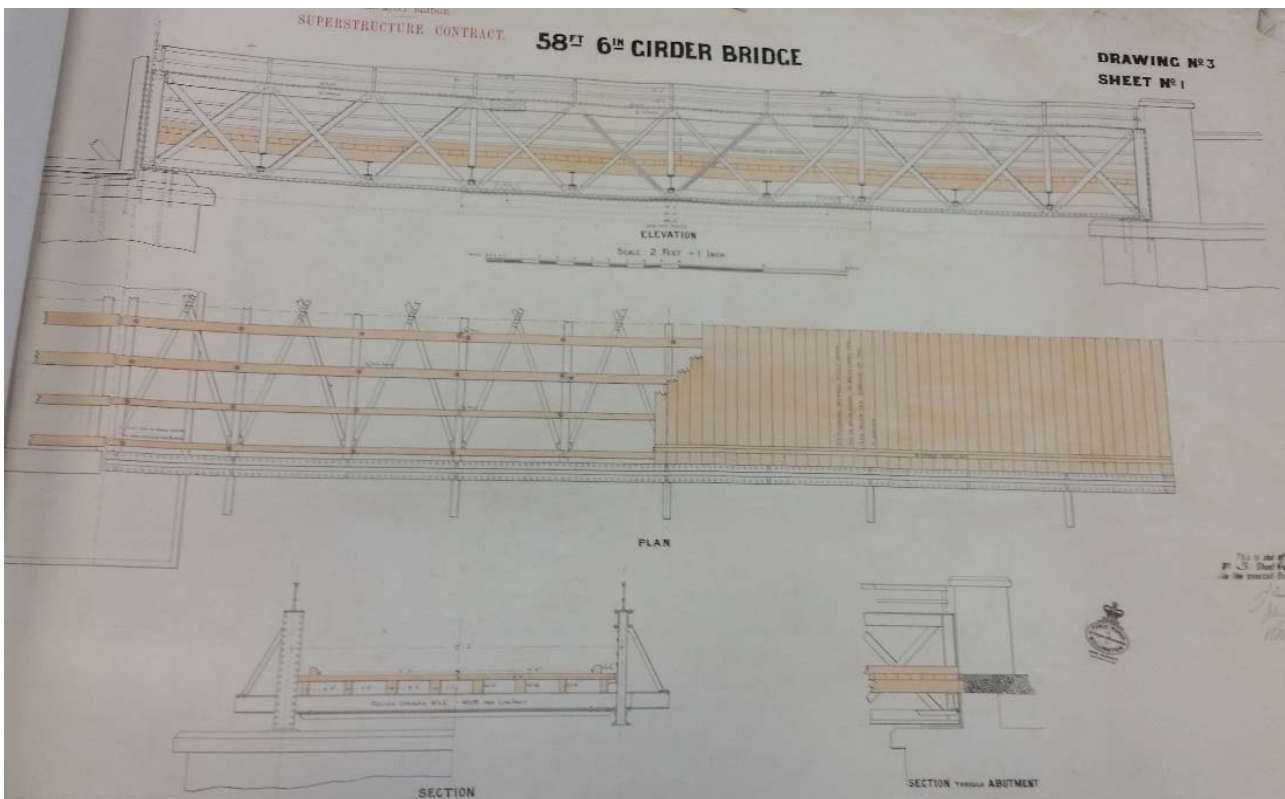

Figure 21: Plans, sections and elevations of the 58ft 6in lattice girders of Beaumont Bridge.

The transoms projecting either side of the lattices and braced back to the top chords, the horizontal cross bracing, and the timber deck structure, are visible.

Source: PWD 12762, Archives New Zealand Ref W5 268

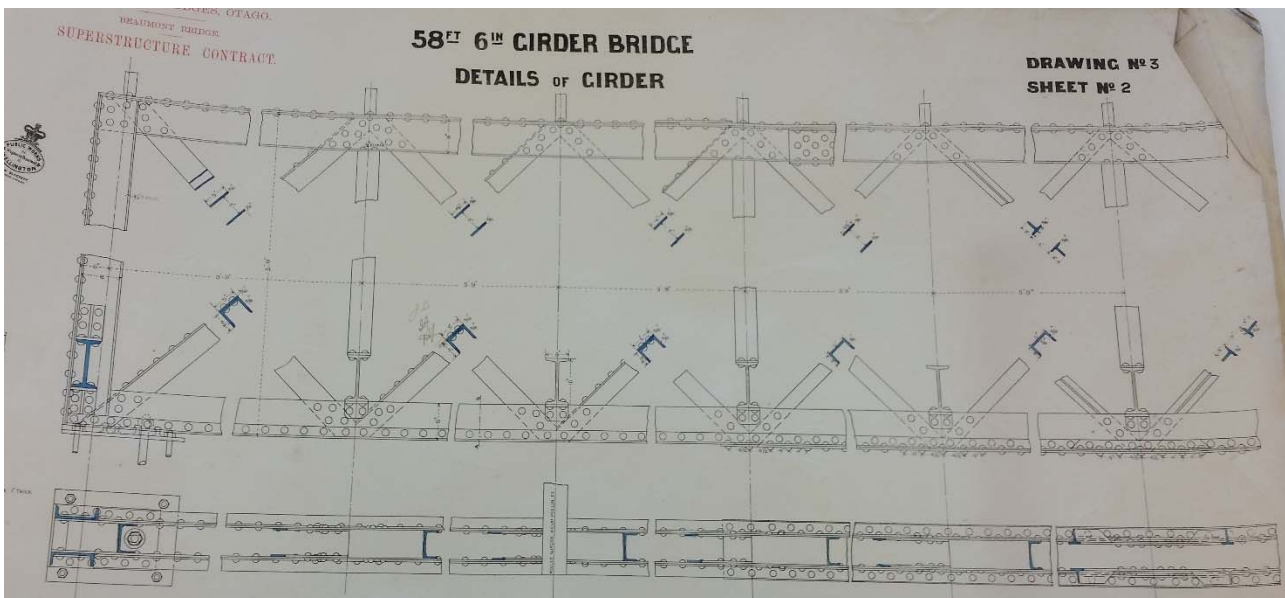

Figure 22: Details of the 58ft 6in lattice girders of Beaumont Bridge.

Source: PWD 12762, Archives New Zealand Ref W5 268

The initial plans and specifications for the Beaumont Bridge were prepared by Public Works Department (PWD) engineer, W. N. Blair. These documents were received by the Tuapeka County

Clerk in April 1883; and tenders were called for construction of the concrete piers and abutments.⁹⁴ The tenders received initially were considered too high; and it was decided to call for fresh tenders in July.⁹⁵ Following receipt of these tenders, the contract for construction of the concrete piers and abutments was awarded to W. R. Buchanan.⁹⁶

While the design of the bridge did not allow the laying of a foundation stone, the first bucket of cement was poured on 21 September 1883 by local MP, Vincent Pyke, a large crowd gathering to witness the ceremony. A time capsule containing local newspapers and coins was placed under the foundation stone; and, following the ceremony, the dignitaries retired for a meal at the Bridge Hotel.⁹⁷

Construction proceeded smoothly until November when, first, an accident, and then heavy flooding, caused some interruption.⁹⁸ The accident was described in the *Tuapeka Times*:

A man named John Boland, employed at the erection of the Beaumont bridge, performed a most wonderful feat and, at the same time, made a most miraculous escape from an immersion in the Molyneux one day last week. Boland, it would appear, was engaged on one of the piers of the bridge in tipping the cement-cage when it came along the rope to the pier; and on one occasion ... after tipping ... he was jerked at once off the pier and left hanging by the one hand in mid-air, about 60 feet above the river. Those standing at the side were almost paralysed for a minute, but realizing the great danger of the situation of their comrade, they at once hit upon the only assistance they could render him, which was to whip up the horse and make the time of suspension as short as possible. Happily a smart, willing horse was at work at the time, and answered the call made upon him at once by bringing Boland speedily ashore, a distance of some 100 yards or upwards.⁹⁹

By Christmas, three bridge piers had been constructed to a height of 10ft above the river, and construction on the abutments had commenced;¹⁰⁰ however, it was becoming apparent that Buchanan would not have the works finished by 31 January 1884 as his contract required. The Tuapeka County Council granted Buchanan an extension to complete the works.¹⁰¹

In June, Buchanan requested that the Council appoint a new inspector of works; but the Council refused.¹⁰² Shortly afterwards, works were suspended again due to weather; this time because of severe frosts.¹⁰³ Meanwhile, the Government confirmed a grant of £4,500 would be made towards construction of the bridge superstructure.¹⁰⁴ Construction of the piers and abutments extended into 1885. According to an article published in the *Tuapeka Times*, construction was once again “progressing rapidly” by April. The article continued:

Mr Buchanan's contract for the piers and abutments is fast approaching completion, and the Government is calling for tenders for the superstructure, which will consist of girders of lattice

⁹⁴ Tuapeka Times, 25 April 1883

⁹⁵ Tuapeka Times, 18 July 1883

⁹⁶ Tuapeka Times, 26 September 1883. W. R. Buchanan is also variously referred to as W. J. Buchanan in some contemporary publications.

⁹⁷ Tuapeka Times, 26 September 1883; Evening Star, 6 October 1883

⁹⁸ Tuapeka Times, 21 November 1883; Tuapeka Times, 24 November 1883

⁹⁹ Tuapeka Times, 21 November 1883

¹⁰⁰ Tuapeka Times, 12 December 1883

¹⁰¹ Tuapeka Times, 15 March 1884

¹⁰² Tuapeka Times, 14 June 1884

¹⁰³ Tuapeka Times, 25 June 1884

¹⁰⁴ Tuapeka Times, 8 November 1884

iron-work and wooden deck. This bridge when finished will be a handsome and substantial structure ...¹⁰⁵

Tenders for the superstructure were received in April 1885; and the tender of John Anderson of Christchurch, being the lowest, was accepted¹⁰⁶ and the contract signed.¹⁰⁷ In August, the piers and abutments were inspected by government engineer Mr Low who was reportedly “highly pleased with the manner in which the contractor has carried out the work”. The site was officially handed over by Buchanan to the PWD, and by the PWD to Anderson.¹⁰⁸

The contract for the superstructure specified that the ironwork was to be manufactured in New Zealand. The contractor was given the option of importing the raw materials; but they had to be imported “exactly in the state in which they left the rolling-mills”.¹⁰⁹ Anderson chose to import the iron from England to his foundry in Christchurch¹¹⁰ before transporting it by rail to Lawrence where the branch line terminated. The iron is reported to have arrived in Lawrence in January 1886,¹¹¹ from where it was carted to the site of the bridge by Messrs Williams and Tubman.¹¹² At the site, Anderson established a small foundry to prepare the raw material.¹¹³ Mechanics were dispatched from the Christchurch foundry to carry out the assembly.¹¹⁴

The requirement for locally manufactured ironwork was controversial, with opponents quick to accuse contractors such as Anderson of getting “the work done in England, leaving only the punching of rivet-holes” or the “putting together of pieces” for local industry to achieve, and pocketing the profits.¹¹⁵ The publication of such accusations led Anderson and his representatives to respond:

... in regard to what is being done to the ironwork for the Beaumont bridge, you lead your readers to believe that all the contractor is doing is to punch a few holes and put the work together, the most of the work having been done in Britain, and by that means enriching themselves at the expense of the colony. Now ... I may state that the iron came from the rolling mills, and was laid down on the bridge site in the same state as any engineering firm in Britain would receive it that had a contract of the same kind to do.¹¹⁶

The Government never contemplated the absurdity of requiring contractors to erect rolling mills for the manufacture of the iron. What they specified was that the iron should be imported in the state in which it left the rolling mills, and that condition has been rigidly adhered to. You clearly are under the impression that the contractors imported the iron with certain work done on it, and I must express my surprise that the few inquiries necessary to dispel that illusion were not made by you.¹¹⁷

Following the arrival of the iron, construction of the superstructure proceeded with speed. By May 1886 one span was almost complete; and Anderson was reported to be confident that he would

¹⁰⁵ Tuapeka Times, 1 April 1885

¹⁰⁶ Otago Daily Times, 13 May 1885

¹⁰⁷ Contract for Superstructure of the Beaumont Bridge, PWD 12762, Archives New Zealand Ref W5 268.

¹⁰⁸ Tuapeka Times, 22 August 1885

¹⁰⁹ Contract for Superstructure of the Beaumont Bridge, PWD 12762, Archives New Zealand Ref W5 268.

¹¹⁰ Tuapeka Times, 9 March 1887

¹¹¹ Otago Witness, 16 January 1886

¹¹² Tuapeka Times, 23 December 1885

¹¹³ Otago Daily Times, 9 March 1887

¹¹⁴ Tuapeka Times, 9 March 1887

¹¹⁵ Otago Daily Times, 15 October 1886

¹¹⁶ Walter Sneddon, “in charge for contractor”, Otago Daily Times, 25 October 1886

¹¹⁷ John Anderson, Contractor for Beaumont Bridge, Otago Daily Times, 28 October 1886

complete the contract by July as required.¹¹⁸ However, this proved to be optimistic. The depth of the river, the strength and the volume of the current, made access difficult, and “it was found necessary to erect a temporary structure of trusses which, to many, had the appearance of a thoroughly permanent work”.¹¹⁹ Difficult weather and delays in arrival of timber for construction of the bridge deck caused further issues;¹²⁰ and, despite having approximately thirty workmen onsite, construction of the superstructure extended into 1887.



Figure 23: Beaumont Bridge in 1887, thought to be around the time of its opening.

Source: bp.blogspot.com

In February 1887, PWD engineers including W. N. Blair made an inspection of the bridge “to see how the colonial material was turning out” and was reportedly pleased with both the materials and the workmanship. At this time it was also reported that the Beaumont Bridge was one of four bridges underway for which the ironwork was being fabricated in New Zealand.¹²¹

On March 7th 1887, the bridge was officially opened. The first crossing was made by Anderson, driving a coach provided by Craig and Co., accompanied by a party of passengers. The men who had been part of the construction assembled on the bridge to cheer the coach as it passed; after which, Anderson treated all of his guests to a champagne luncheon at the Bridge Hotel.¹²²

The IPENZ Record for the Beaumont Bridge summarises its construction succinctly:

The Beaumont Bridge took one year to construct, but the entire project was three and a half years in the making. When the Beaumont Bridge was eventually completed it was described as “a lasting monument of the undoubted excellence of New Zealand workmanship.”¹²³

Contemporary reports state that over 170 tons (approximately 173 metric tonnes) of wrought iron were used in the construction of the superstructure. The weight of timber used is not mentioned. The iron was finished with three coats of hematite paint, and all joints in the woodwork, and

¹¹⁸ Tuapeka Times, 26 May 1886

¹¹⁹ Tuapeka Times, 9 March 1887

¹²⁰ Tuapeka Times, 11 December 1886

¹²¹ Tuapeka Times, 16 February 1887

¹²² Otago Daily Times, 9 March 1887; Tuapeka Times, 9 March 1887

¹²³ IPENZ (nd b) www.ipenz.org.nz

between wood and iron, were coated with white lead and oil. The cost of the superstructure was £5,000 which, when added to the cost of the piers and abutments, gave a total construction cost of £11,050 – a considerable sum at the time.



Figure 24: Beaumont Bridge in 1887 shortly after completion.

Source: Hocken Collections Asset ID 6263



Figure 25: Beaumont Bridge c.1890. The Bridge Hotel is visible in the background.

Source: Hocken Collection Asset ID 6264



Figure 26: Beaumont c.1890s showing a horse drawn carriage about to cross the bridge on the left, departing from the Bridge Hotel on the right.

Source: Hocken Collections Asset ID 626317340

2.2.2 Alterations & Maintenance Works

Maintaining the Beaumont Bridge proved to be a difficult task for the Tuapeka County Council. According to the published proceedings of a Council meeting in October 1902, the deck of the Beaumont Bridge was already in need of replanking, and the ironwork in need of repainting.¹²⁴ Cleaning and painting works were carried out in 1903;¹²⁵ however, the decking remained an issue. In January 1906 the County Engineer reported that he had obtained some Jarrah planks to trial on the deck of the bridge.¹²⁶ A year later, it was reported that a number of bridge decks in the area had split “owing to the exceedingly dry weather” and that this was most noticeable on the Beaumont Bridge “which must be redecked as soon as possible”.¹²⁷ However, it is not until November 1911 that the cost of timber attributed to the Beaumont Bridge appears in the Public Works Engineer’s report.¹²⁸ It is assumed, but not confirmed, that this timber was for redecking purposes.

The bridge withstood serious flooding in October 1912¹²⁹ and again in 1919.¹³⁰ In June 1920, the Public Works Engineer’s report shows costs of £200 attributable to the Beaumont Bridge, but does not state what these costs are for.¹³¹

¹²⁴ Tuapeka Times, 11 October 1902

¹²⁵ Otago Witness, 22 April 1903

¹²⁶ Otago Witness, 24 January 1906

¹²⁷ Tuapeka Times, 12 January 1907

¹²⁸ Mt Bengier mail, 29 November 1911

¹²⁹ North Otago Times, 18 October 1912

¹³⁰ Otago Daily Times, 30 June 1919

¹³¹ Tuapeka Times, 12 June 1920

In 1921 the Council received complaints that the planks of the bridge were loose and spikes were protruding, risking damage to the tyres of motor cars. This followed an earlier communication from the Teviot Motor Lorry Association, received by the Council in 1917, which requested an improvement to the deck, “its present condition being a serious menace” to motorised traffic.¹³² By way of reply, the Council Engineer explained:

that the bearers were not as sound as they should be and that they would not hold the spikes, which were frequently being driven down. He did not think there was much in the suggestion that motor tyres were being punctured. However, Mr T. Philipps had his instructions to keep a close watch on the planking and see that the spikes were kept down.¹³³



Figure 27: Bridge Hotel with vehicles parked outside, 1918.

This image demonstrates the type of motorised vehicles that were regularly using the bridge (located behind the photographer) by this time. Note the vehicle of J. F. Tamblyn in the centre. In 1926, Tamblyn narrowly escaped dropping through the deck of the Beaumont Bridge into the river while repairs were being undertaken.

Source: Hocken Collections Asset ID 6260

The condition of the paintwork was also raised again in 1921, with the Council resolving to apply to the PWD for a £ for £ grant to undertake the works.¹³⁴ This application was refused, the Minister of Public Works ruling that it was local work and therefore the Council’s sole responsibility.¹³⁵ The Council disputed this, and disagreement between the two parties continued for several years, by

¹³² Mt Benger Mail, 17 January 1917

¹³³ Mt Benger Mail, 13 April 1921

¹³⁴ Mt Benger Mail, 13 April 1921

¹³⁵ Otago Daily Times, 11 July 1921

which time it was also noted that the bridge required “some new beams” and other repairs to the superstructure.¹³⁶

In 1924, it was agreed that Council would, again, make a plea to the PWD for a £1 for £1 subsidy on the basis that the painting work was now urgent and would cost approximately £1,000.¹³⁷ The PWD agreed to a subsidy of £1 for £2, with the work to be carried out by PWD staff.¹³⁸ At the Council’s annual meeting on 3 June 1925 it was reported that “the painting and repairing of the understructure of Beaumont traffic bridge by the PWD” was underway.¹³⁹

The following year, the bridge was completely redecked. In August 1926, the Council Engineer reported:

The re-decking of the big bridge at Beaumont is again in hand and good progress is being made. In this connection I have to report that a lorry laden with clay pipes, owned by Mr J. F. Tamblyn, had a narrow escape of dropping through on to the river bed. The bridge was open for traffic for half its width and the lorry was passing over the old portion of the bridge when the stringers broke, and it was only by speeding up that what might have been a serious accident was averted. I suggest that during the progress of repairs the loads using the bridge to restricted to a reasonable weight.¹⁴⁰

The Councillors agreed that load weights should be restricted, and the works were reported as being complete in October 1926.¹⁴¹ However, the deck was again proving problematic by 1930, and new running planks were installed. In reporting the completion of this work, the Mt Benger Mail stated:

The placing of the running planks has been completed and this should save the decking for some considerable time. On examination it was found that the bottom flanges of the lower chords were rusting badly, and these are now being cleared and painted with bitumen.¹⁴²

Despite the hope that the running planks would future-proof the deck, a decision to lay gravel was made in 1935 as a method of postponing redecking which would “soon be necessary”.¹⁴³

The Beaumont Bridge underwent a programme of strengthening during the 1960s and 70s. It is understood that the king post trusses strengthening each of the transoms were added during this time; first to the long spans, and then to the shorter end spans.¹⁴⁴

In 2009, the NZ Transport Agency carried out some repair and maintenance to the Beaumont Bridge. As this work got underway, the Agency announced that it would be investigating the feasibility of replacing the bridge due to the ongoing costs and traffic disruption associated with maintaining the bridge deck and structure.¹⁴⁵ In 2010, the NZ Transport Agency added permanent traffic signals at each end of the bridge to slow the traffic down and prolong the life of the structure. Niclas Johansson, the Regional State Highways Manager at the time, stated:

¹³⁶ Mt Benger Mail, 16 November 1921; Mt Benger Mail, 26 April 1922; Mt Benger Mail, 28 June 1922

¹³⁷ Otago Daily Times, 13 October 1924

¹³⁸ Mt Benger Mail, 17 December 1924

¹³⁹ Mt Benger Mail, 3 June 1925

¹⁴⁰ Mt Benger Mail, 18 August 1926

¹⁴¹ Otago Daily Times, 29 October 1926

¹⁴² Mt Benger Mail, 15 October 1930

¹⁴³ Mt Benger Mail, 17 July 1935

¹⁴⁴ Opus International Consultants (2015a)

¹⁴⁵ NZ Transport Agency (2009) www.nzta.govt.nz

The decision to install the signals was taken to lower vehicle speeds to help reduce stress and wear and tear on the bridge, especially from heavy trucks. The bridge deck timber is also prone to movement and this is aggravated by high traffic speeds.¹⁴⁶

Scaffolding erected for earlier repair works remained at the bridge to allow regular monitoring and access for any necessary repairs.¹⁴⁷

In October 2011, the *Otago Daily Times* reported that the safety of the Beaumont Bridge was questioned by local government officials at a meeting of the Otago Regional Council's transport committee. The article continued:

The NZTA has been spending money on the bridge as it seeks to extend the life of the 123-year-old structure. About \$1.5 million was spent on maintenance during the period 2005-10. A decision on replacing the bridge may be on the back-burner because of the possibility a hydro dam could be built in the area, flooding Beaumont... A new bridge had been earmarked for construction sometime after 2015 ... However, the NZTA was yet to commission any design plans for a new bridge.¹⁴⁸

In 2014, repairs to the deck costing \$150,000 were carried out.¹⁴⁹ This was followed in 2015 by strengthening works to enable the bridge to carry High Performance Motor Vehicles (HPMV) with loads of up to 62 tonnes,¹⁵⁰ as well as replacement of a damaged strut in one of the lattice girders,¹⁵¹ and further deck repairs.¹⁵² A regular inspection programme continues at the time of preparing this Assessment, with the bridge being periodically closed for strengthening and maintenance works.¹⁵³ The current condition of the structure is varied. The concrete piers appear to be in reasonably sound condition, though there is staining and microbiological growth and some cracking evident. However, the concrete abutments are exhibiting serious signs of failure - particularly the west abutment. The deck is exhibiting signs of wear, with areas of the surface worn away. Below the deck, there is a build-up of dirt and microbiological growth evident on the decking timbers, timber bearers, transoms, horizontal cross braces, and bottom chords of the lattice girders. Recent repairs of connections and fatigued ironwork are evident. Drawings of repair works undertaken in 2015 are provided in Appendix 2.

2.2.3 Current Condition

The bridge remains scaffolded to enable regular inspections. It is estimated that approximately 1,800 vehicles, including HPMVs, cross the bridge each day.¹⁵⁴ The current condition of the bridge is captured in Figure 28 to Figure 38 below.

¹⁴⁶ NZ Transport Agency (2010) www.nzta.govt.nz

¹⁴⁷ NZ Transport Agency (2010) www.nzta.govt.nz

¹⁴⁸ Otago Daily Times, 31 October 2011

¹⁴⁹ NZ Transport Agency (2014) www.nzta.govt.nz

¹⁵⁰ NZ Transport Agency (2015a) www.nzta.govt.nz

¹⁵¹ Opus International Consultants (2015a)

¹⁵² NZ Transport Agency (2015b) www.nzta.govt.nz

¹⁵³ NZ Transport Agency (2016) www.nzta.govt.nz

¹⁵⁴ Otago Daily Times, 27 June 2015



Figure 28: Beaumont Bridge viewed from south.



Figure 29: South elevation of west abutment. Staining, microbiological growth and cracking are visible. Note also the strengthening works that have been carried out.



Figure 30: North elevation of west abutment. Serious cracking and delamination of the concrete are visible.



Figure 31: Concrete pier.
Staining, microbiological growth, cracking, and graffiti are visible.



Figure 32: Lattice girder behind scaffold.
Transom ends are visible, intersecting with bottom chord.



Figure 33: Intersection between small and large lattice girders.



Figure 34: Bridge deck looking west.
The poor condition of the deck surface is evident.



Figure 35: Understructure of the bridge showing king post trusses strengthening transoms and cross bracing below timber deck.
Microbiological growth and accumulation of dirt is evident.



Figure 36: Recent repair of wrought iron bottom chord.



Figure 37: Timber bearers on wrought iron transom.

Microbiological growth and accumulation of dirt is evident.



Figure 38: Timber bearers and edge of timber decking.

Microbiological growth and accumulation of dirt is evident.

2.3 Persons and Groups Associated with the Building

2.3.1 W. N. Blair

William Newsham Blair was born in the Scottish Hebrides, immigrating to Dunedin in 1863 when he was in his early 20s. He was first employed by Otago's Chief Engineer of Roads, then Chief Engineer of Railways, before being appointed as District Engineer to Otago and Southland under the newly created PWD. In this role, Blair was responsible for the construction of all of Otago and Southland's railways, and many of the roads and bridges.¹⁵⁵

When the PWD was divided in 1878, Blair was put in charge of the South Island division (known at the time as Middle Island). It is during this period that he was involved with the Beaumont Bridge. Various contemporary sources credit Blair with preparing the drawings and specifications for the first tender; though documents prepared for the superstructure are credited to John Blackett.¹⁵⁶

In February 1887, the Tuapeka Times reported:

Yesterday Mr W. N. Blair, Engineer-in-Chief of the Middle Island, accompanied by Mr Ussher, District Engineer, paid a visit of inspection to the new Beaumont bridge ... The object of Mr Blair's visit was to see how the colonial material was turning out; and we are pleased to learn that he is thoroughly satisfied, not only with the material, but with the workmanship, which is of a truly excellent character throughout.¹⁵⁷



Figure 39: William Blair, photographed by Burton Bros, date unknown.

Source: Otago Settlers Museum, Ref PC 00 0094

¹⁵⁵ Williams (updated 2013) www.TeAra.govt.nz

¹⁵⁶ Contract for Superstructure of the Beaumont Bridge, PWD 12762, Archives New Zealand Ref W5 268.

¹⁵⁷ Tuapeka Times, 16 February 1887

This conflicts with more recent sources, according to which Blair was removed from his South Island (Middle Island) post in 1884 when the PWD reamalgamated, moving to Wellington to take up the role of national Assistant Engineer-in-Chief.¹⁵⁸

Whatever the case, it would seem that he succeeded John Blackett as Engineer-in-Chief in 1890, when he was also appointed as Under Secretary of the Department. He held these positions for a year until a long period of illness led to his premature death in 1891. A widely recognised and respected public servant, Blair's cortege made a public procession from Wellington to Dunedin, where his funeral was held at Knox Church. He is remembered "both for his achievements in engineering and for his capacity to inspire lasting affection".¹⁵⁹

2.3.2 John Blackett

John Blackett was born in Newcastle upon Tyne, England, where he trained and practised as a draughtsman and then as an engineer specialising in ships and mines. He immigrated to New Zealand with his wife in 1851, settling first in Taranaki where they established a farm. Following a short commission as an ensign in the New Plymouth Battalion of Militia, Blackett and his family moved to Nelson where he took up the role of Provincial Engineer, overseeing the construction and maintenance of roads, bridges, wharves, lighthouses, buildings, and the Nelson city waterworks.¹⁶⁰

In 1870, Blackett was appointed as the Public Work Department's acting Engineer-in-Chief, and moved to Wellington. Following the arrival of the new Engineer-in-Chief, Blackett was appointed as Assistant Engineer-in-Chief and Marine Engineer to the general government. In this role he oversaw the erection of fourteen lighthouses. When the PWD was divided in 1878, Blackett was put in charge of the North Island division, becoming Engineer-in-Chief upon reamalgamation.¹⁶¹

Drawings and specifications included in the contract for the construction of the superstructure of the Beaumont Bridge, dated 1885, are attributed to Blackett. Whether the design is attributable to him, or to Blair, is unclear. Given their closely aligned positions within the PWD, it is considered likely that both men were involved with the design.

In 1889, Blackett accepted an appointment as consulting engineer for the New Zealand government in England; and was succeeded as Engineer-in-Chief by W. N. Blair. However, he resigned within a few years because of ill health, returning to Wellington where he died on 8 January 1893.¹⁶² Blackett made a considerable contribution to infrastructure and marine engineering in New Zealand.



Figure 40: John Blackett, photographed by Wrigglesworth & Binns Wellington, August 1891.

Source: Alexander Turnbull Library, Ref 1/2-080821

¹⁵⁸ Williams (updated 2013) www.TeAra.govt.nz

¹⁵⁹ Williams (updated 2013) www.TeAra.govt.nz

¹⁶⁰ Orr (updated 2012) www.TeAra.govt.nz/en/biographies

¹⁶¹ Orr (updated 2012) www.TeAra.govt.nz/en/biographies

¹⁶² Orr (updated 2012) www.TeAra.govt.nz/en/biographies

2.3.3 W. R. Buchanan

Little information is available on W. R. Buchanan. It is evident from contemporary newspaper reports and letters to the editor that the quality of Buchanan's work, and the speed at which construction of the piers and abutments was carried out under his supervision, was a matter of public concern. After the completion of his contract, Buchanan entered a dispute with the Tuapeka County Council, claiming that he had not been paid for construction of coffer dams required to construct the bridge piers;¹⁶³ and that he had been unfairly maligned for problems that had arisen over the height of the piers themselves.¹⁶⁴ The Council asked the Government to make an inquiry into Buchanan's claims.¹⁶⁵ Eventually, almost a year later, the matter was resolved at a council hearing.¹⁶⁶

2.3.4 John Anderson (the younger)

John Anderson (the younger) immigrated to New Zealand as a small child with his parents Jane and John Anderson (the elder), arriving in Lyttelton in 1850 and settling in Christchurch. John Anderson (the elder) had trained as a blacksmith, and established a business and home in Cashel Street.

In 1857 the plant of "J. Anderson, Engineer, Millwright, Boiler Maker &c" ... expanded to include a foundry, for which raw materials were imported. Anderson acquired agencies for a range of equipment imports; in particular, Aveling and Porter traction engines and road rollers... In the next decade the firm began to manufacture steam boilers and also made equipment to process the province's primary products, especially wool, flax and livestock.¹⁶⁷

With a successful business and expanding share portfolio, the elder John Anderson's wealth quickly grew. This enabled him to send the younger John Anderson, along with his brother Andrew, to Glasgow for their formal education in 1866. John the younger returned to New Zealand in 1873, followed three years later by Andrew, and both took up a role in the family business. The Beaumont Bridge was the first major project undertaken by John Anderson the younger, with his father acting only as guarantor.¹⁶⁸ Following the success of the project, the Anderson brothers went on to establish one of New Zealand's most important construction companies of the era.¹⁶⁹

In particular, it gained a reputation for building road and rail bridges.... Alluvial gold dredges were also built, and vessels were constructed and repaired at the Lyttelton works, which opened in 1887. Local expertise for large-scale projects was regarded as suspect but the firm undertook major contracts, including the impressive viaducts at Waiteti (1888) [Figure 41] and Makatote (1908) on the main trunk railway, and the manufacture of the steel lighthouse for Farewell Spit (1895–96). In 1903 a private limited liability company, Anderson's Limited, was formed. It merged with Mason Brothers Limited in 1964 and ceased trading in 1986.¹⁷⁰

The works of the Anderson brothers remain some of the most enduring examples of visionary engineering of the era.

¹⁶³ Tuapeka Times, 13 March 1886

¹⁶⁴ Tuapeka Times, 11 August 1886

¹⁶⁵ Otago Witness, 17 September 1886

¹⁶⁶ Tuapeka Times, 9 July 1887

¹⁶⁷ Lowe (updated 2012) www.TeAra.govt.nz

¹⁶⁸ Contract for Superstructure of the Beaumont Bridge, PWD 12762, Archives New Zealand Ref W5 268.

¹⁶⁹ Thornton (2001) p134

¹⁷⁰ Lowe (updated 2012) www.TeAra.govt.nz

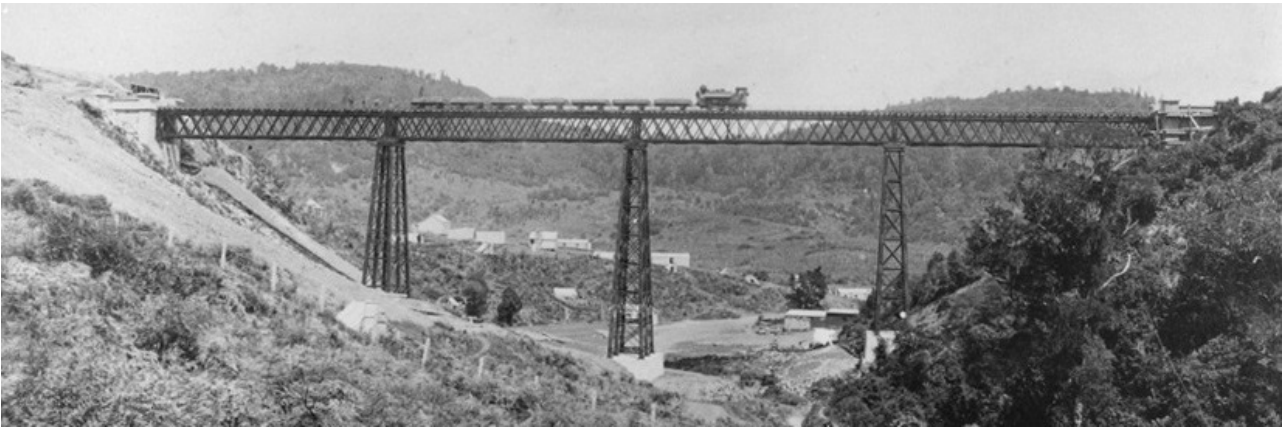

Figure 41: Train crossing the Waiteti Viaduct c.1888-90.

Source: Auckland Council Libraries, Record ID 4-1078

2.4 Archaeological Sites

There are six NZAA registered sites within a 1,000km radius of the Beaumont Bridge (Figure 42).

Five sites lie north of the bridge. Four of these sites – G44/64, G44/86, G44/88 and G44/143 – are associated with the dredging of the river and mining for gold, including the remains of two huts. Site G44/87 encompasses the remains of stone abutments of the Beaumont Creek Bridge. Two sites lie southeast of the bridge, both of which are associated with pre-European occupation of the area. G44/3 is the site of several ovens estimated to date to the mid-18th century. G44/4 marks the location of an artefact find: a Maori adze discovered by the property owner in 1966.

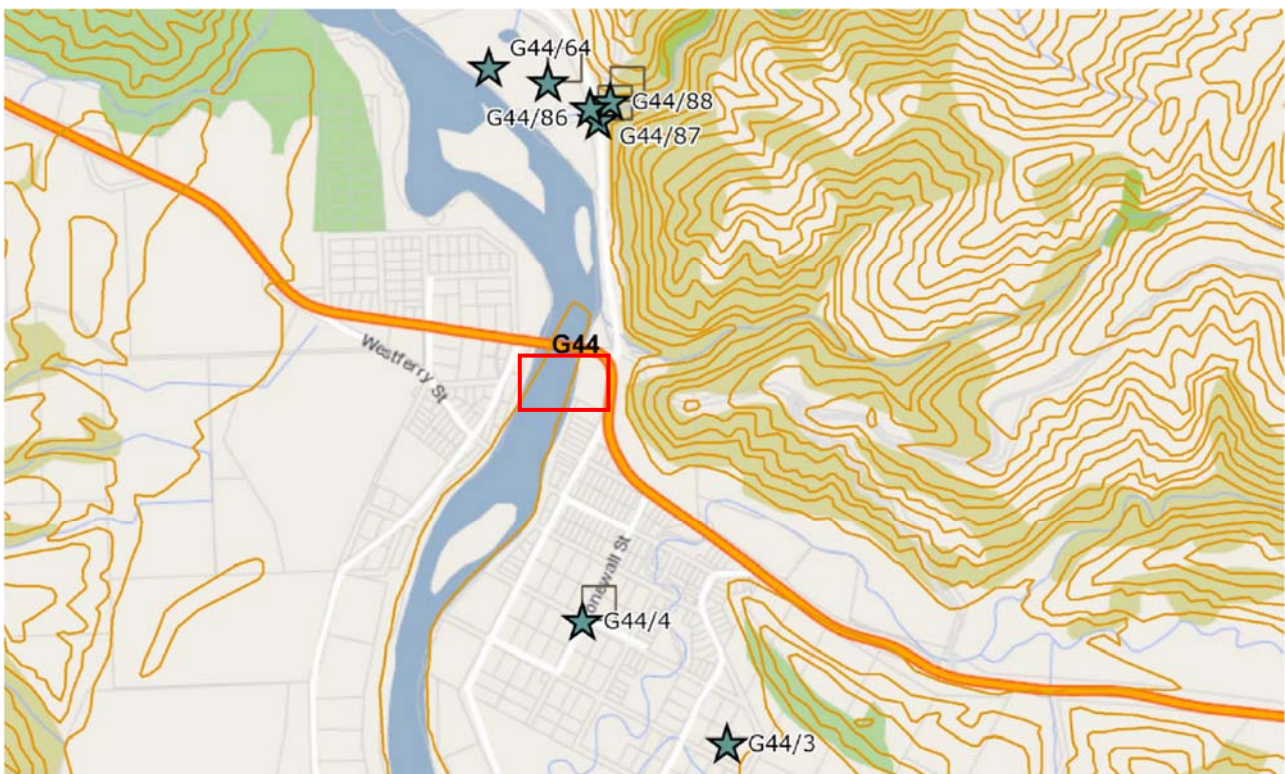

Figure 42: Map showing location of NZAA registered archaeological sites within the vicinity of the Beaumont Bridge.

The bridge is indicated in red, below G44. Source: nzaa.eaglegis.co.nz

3 Assessment of Heritage Significance

3.1 Methodology for Assessing Cultural Heritage Significance

3.1.1 Categories of Significance

Identifying and assessing heritage values can be a complex process. At present there is no legislative procedure or established common methodology for assessing the heritage significance of a place in New Zealand; however, there are a variety of precedents and guidelines. Those precedents and guidelines that are considered to be particularly relevant to the New Zealand context, or are considered to be respected international precedents, are outlined below.

3.1.1.1 ICOMOS New Zealand Charter for the Conservation of Places of Cultural Heritage Value, Revised 2010

The ICOMOS New Zealand Charter for the Conservation of Places of Cultural Heritage Value, Revised 2010 (ICOMOS NZ Charter) sets out principles to guide the conservation of places of cultural heritage value in New Zealand.

Under the ICOMOS NZ Charter, a place is considered to have cultural heritage significance where it possesses:

... aesthetic, archaeological, architectural, commemorative, functional, historical, landscape, monumental, scientific, social, spiritual, symbolic, technological, traditional, or other tangible or intangible values, associated with human activity.¹⁷¹

Article 2 of the ICOMOS NZ Charter states that, in assessing the significance of a place, all aspects of cultural heritage value should be considered and understood, even where these values differ or conflict. The ICOMOS NZ Charter identifies authenticity and integrity as crucial aspects of cultural heritage value. Definitions of these terms can be found in the Charter, provided in Appendix 1.

3.1.1.2 Resource Management Act 1991

The purpose of the Resource Management Act 1991 (RMA) is to promote sustainable management of natural and physical resources in New Zealand, which includes historic heritage. The RMA requires local authorities to identify and protect historic heritage within their jurisdiction, where historic heritage is defined as:

- a) those natural and physical resources that contribute to an understanding and appreciation of New Zealand's history and cultures, deriving from any of the following qualities:
 - (i) archaeological;
 - (ii) architectural;
 - (iii) cultural;
 - (iv) historic;
 - (v) scientific;
 - (vi) technological.¹⁷²

¹⁷¹ ICOMOS NZ (2010)

¹⁷² RMA 1991 section 2. And includes:

- (i) historic sites, structures, places, and areas; and
- (ii) archaeological sites; and

3.1.1.3 Heritage New Zealand Pouhere Taonga Act 2014

The purpose of the Heritage New Zealand Pouhere Taonga Act 2014 (HNZPTA) is to promote the identification, protection, preservation, and conservation of the historical and cultural heritage of New Zealand. The HNZPTA identifies criteria for establishing significance that are used to establish whether or not a place may be assigned Category I or II status on the New Zealand Heritage List as follows:

- a) the extent to which the place reflects important or representative aspects of New Zealand history;
- b) the association of the place with events, persons, or ideas of importance in New Zealand history;
- c) the potential of the place to provide knowledge of New Zealand history;
- d) the importance of the place to tangata whenua;
- e) the community association with, or public esteem for, the place;
- f) the potential of the place for public education;
- g) the technical accomplishment, value, or design of the place;
- h) the symbolic or commemorative value of the place;
- i) the importance of identifying historic places known to date from an early period of New Zealand settlement;
- j) the importance of identifying rare types of historic places;
- k) the extent to which the place forms part of a wider historical and cultural area.¹⁷³

3.1.1.4 Clutha District Council

The RMA requires all territorial authorities to prepare a district plan to assist them in carrying out their functions in order to achieve the sustainable management purpose of the RMA.¹⁷⁴ One of these functions is the identification of historic heritage resources, and the protection of these resources from inappropriate subdivision, use, and development.¹⁷⁵

Buildings and structures identified and protected for their cultural heritage value under the operative Clutha District Plan are listed in Chapter 3.5, Table 13.1: Register of Heritage Buildings. The District Plan does not provide a set of criteria by which the buildings and structures included in the Register have been evaluated. Section 3.5.5 states that the Register includes buildings on the New Zealand Heritage List, and other buildings and structures “identified by the Council through public consultation”.

3.1.1.5 Otago Regional Policy Statement

The RMA requires every region to prepare a regional policy statement that provides an overview of issues surrounding the use of natural and physical resources of the region; and set out policies to, and methods of, managing these resources.¹⁷⁶

-
- (iii) sites of significance to Māori, including wāhi tapu; and
 - (iv) surroundings associated with the natural and physical resources

¹⁷³ HNZPTA 2014 section 66

¹⁷⁴ RMA 1991 section 72

¹⁷⁵ RMA 1991 section 6

¹⁷⁶ RMA 1991 section 59

Chapter 9 of the Otago Regional Policy Statement (RPS) sets out the issues, objectives and policies of the Otago Regional Council that relate to the built environment.

Policy 9.5.6 of the Otago Regional Policy Statement (RPS) aims to recognise and protect Otago's regionally significant heritage sites by:

- a) identifying Otago's regionally significant heritage sites in consultation with Otago's communities; and
- b) developing means to ensure those sites are protected from inappropriate subdivision, use and development ...

where "heritage site" is defined in Chapter 16: Appendix as:

any place or object of special cultural, architectural, historical, scientific, ecological or other interest, or of special significance to the tangata whenua for spiritual, cultural or historical reason.¹⁷⁷

3.1.1.6 New Zealand Transport Agency Guidelines

In 2015, the NZ Transport Agency published a guidance document entitled *Historic Heritage Impact Assessment Guide for State Highway Projects*. This document identifies the following criteria for assessment of heritage significance:

Physical Values	archaeological information architecture technology and engineering scientific rarity representativeness integrity vulnerability context or group
Historic Values	people events patterns
Cultural Values	identity public esteem commemorative education tangata whenua statutory recognition ¹⁷⁸

¹⁷⁷ "Archaeological site" is defined in Chapter 16 as per the HNZPTA.

¹⁷⁸ NZ Transport Agency (2015) pp15-16. Refer to this document for descriptions of the criteria.

3.1.2 Degree of Significance

To assess the degree of each significance associated with the Beaumont Bridge and its immediate setting, the following graduated scale has been used:

Exceptional

The structure and/or site has exceptionally high value in respect of the criteria considered.

High

The structure and/or site has high value in respect of the criteria considered.

Moderate

The structure and/or site has moderate value in respect of the criteria considered.

Little or None

The structure and/or site has little or no value in respect of the criteria considered.

3.2 Assessment of Cultural Heritage Significance

This section provides an assessment of heritage significance of the Beaumont Bridge based on the criteria set down in the documents outlined in Section 3.1; particularly those in the RMA and the *Historic Heritage Impact Assessment Guide for State Highway Projects*.

3.2.1 Archaeological Significance

The place has the potential to contribute information about human history of the region, or current archaeological research questions, through investigation using archaeological methods; or is known to date from an early period of New Zealand settlement.

The site of the Beaumont Bridge has known associations with Maori settlement dating from the 13th century, and European settlement dating from the mid-19th century. There are several recorded NZAA sites in the vicinity of the bridge, and the bridge itself is a pre-1900 structure. It is evident, therefore, that the bridge and surrounding area has the potential to contribute considerable information about the human history of the region through archaeological investigation; and may directly inform a growing body of knowledge regarding pre-European occupation of Central Otago. It is therefore considered that the Beaumont Bridge and surrounding area have high, and possibly exceptional, archaeological value. This should be further investigated by way of an archaeological assessment.

3.2.2 Architectural or Aesthetic Significance

Is the place or area a good example of its type in terms of design, form, features, scale, style, materials or ornamentation; has integrity, retaining significant features from its time of construction, or later periods when important modifications were made.

Although the Beaumont Bridge has been altered as part of strengthening and maintenance works carried out over the last 50 years, the Beaumont Bridge remains a well preserved example of a pre-1900 iron lattice-girder road bridge that retains its original features and scale, and much of its original fabric. The structure is simple and clean, with no embellishment or ornamentation. However, the elegantly designed and constructed iron lattice girders, and the commanding concrete piers and abutments are strong aesthetic features, and these remain largely intact. Where

repairs have been made these have been carried out with the objective of preserving overall aesthetic value. While they have arguably altered the appearance of the bridge, king post trusses added to strengthen the transoms were sensitively designed, and may now be considered an important feature of the structure. In this respect, it may be considered that the bridge has high aesthetic value.

3.2.3 Contextual or Landmark Significance

The place is part of a wider historical area such as a group of heritage places, a landscape, a townscape or setting; holds visual appeal as a point of special interest or landmark.

The position of Beaumont Bridge in the gorge and its elevation above the riverbed give the structure prominence within the landscape, especially when viewed on approach from the south. The bridge is by far the strongest and most easily recognisable structure within the Beaumont settlement; the second being the Beaumont Hotel. Occupying the site of the earlier Bridge Hotel, the proximity of this building to the bridge is contextually significant, as the two have always been intrinsically connected. It is therefore considered that the Beaumont Bridge has exceptional contextual and landmark value.

3.2.4 Cultural or Spiritual Significance

The place is important to tangata whenua; representative of community, regional or national identity; is held in high public esteem or sentiment; provides evidence of cultural or historical continuity; holds symbolic or commemorative value; is the focus for religious, political or other cultural activity.

This Heritage Significance Assessment does not present the views or history of tangata whenua regarding the cultural significance of the place as these views can only be expressed by tangata whenua themselves.

Having stood and remained in use for 130 years, the Beaumont Bridge certainly provides evidence of cultural or historical continuity since the time of European settlement in the area. While it is evident that the structure is not necessarily held in high public esteem – this being associated with perceived safety issues and regular closing of the bridge for maintenance works – it is also evident that the Beaumont community has a strong sense of identity, and wishes to preserve its history. This is clear when reading the websites of community groups such as *Hands off Beaumont* that formed to protest the ongoing threat of flooding of the town for construction of hydroelectric dams. Therefore, while the bridge is not the focus of cultural or spiritual activity, and is the subject of some negative sentiment, it is never-the-less considered that the structure has high cultural value due to its associations with a strong community identity and connection with the past.

3.2.5 Historic or Social Significance

The place is associated with an important event in local, regional or national history; a well-known or important individual, group or organisation; reflects or represents important aspects, themes or ideas of local, regional or national history.

As the history of both the Beaumont Bridge and the wider Beaumont township given in this Assessment demonstrate, the bridge is integral to the development of Beaumont and the wider area. The extant bridge is intrinsically connected with the establishment of a punt, and the bridge that preceded it, which in turn drove the establishment of a settlement in this location. As a

township, Beaumont has played a crucial role in the opening up of the Upper Clutha to both road and rail. The Beaumont Bridge has associations with important individuals who were influential on a national level, including two leading PWD engineers and the pioneering contractor and businessman, John Anderson. Considering these factors, it is evident that the Beaumont Bridge has exceptional historic value.

3.2.6 Scientific Significance

The place has the potential to provide scientific information about the region or New Zealand; or to provide public education.

Taking into account the archaeological and technological significance of the Beaumont Bridge discussed in this section, it is evident that the bridge has considerable potential to contribute to scientific information about the local area, wider region, and New Zealand. There are also opportunities for public education that may be enhanced through installation of targeted interpretive material.

3.2.7 Technological Significance

The place demonstrates innovative or important methods of construction, engineering or materials; is an early example of the use of a particular construction technique; demonstrates technical accomplishment; or has the potential to contribute information about technological or engineering history.

As one of the first – and possibly *the* first - of four bridges constructed with wrought iron components assembled in New Zealand, the Beaumont Bridge embodies innovative methods of construction not previously used in the country. Anderson's approach of bringing the raw material to the site and establishing a site foundry especially for construction was replicated with success on much larger projects.¹⁷⁹ Believed to be the oldest bridge of its kind in New Zealand, and still in operation on the state highway network, the Beaumont Bridge contributes significant information about the technological and engineering history of both Otago and wider New Zealand. It is therefore considered that the Beaumont Bridge has exceptional technological value.

3.2.8 Comparative Analysis

The place, or features of the place, are a rare, unique or representative example in a local, regional or national context.

There are few road bridges still in operation in New Zealand that are directly comparable to the Beaumont Bridge. Those that have been identified in the course of research for this Assessment are outlined below. They are given in order from most to least similar.

The Iron Bridge just north of the small settlement of Lyell in the Upper Buller Gorge was opened in 1890. The design required special care due to the location, the height of the bridge being approximately 30m above the riverbed in an area subject to severe flooding. According to Thornton (2001) the ironwork was fabricated by Andersons in Christchurch, shipped from Lyttelton to Westport, and carted to the site where it was assembled in a similar manner to the

¹⁷⁹ IPENZ (nd b) www.ipenz.org.nz

Beaumont Bridge. The piers are masonry, founded on concrete-filled cast iron cylinders; and the deck is timber. It is a single-lane bridge, and traffic lights have been installed at either end.

The Iron Bridge suffered damage in the Murchison and Inangahua earthquakes, but remains standing and operational as a road bridge. Of the comparisons considered in this section, the Iron Bridge is the most similar to the Beaumont Bridge. It is not listed with HNZPT.



Figure 43: Iron Bridge, Lyell.

Source: www.flickr.com

The Taramakau Bridge is a combined road and rail bridge on SH6. The following information is extracted from an archaeological assessment for works relating to the bridge prepared by O'Connell (2016):

In 1879 the government began the Greymouth-Hokitika railway. Its construction necessitated the building of a railway bridge spanning the Taramakau River. The Public Works Department designed the bridge and by 1887 it was under construction ... Construction was carried out by the Scott Brothers Atlas foundry of Christchurch, an engineering and manufacturing firm, and it was completed in 1889 ... The Taramakau Bridge is a combined road-rail bridge comprising six steel through truss spans of a double lattice design. It has a concrete abutment at either end of five piers, each pier consisting of two cast iron cylinders.¹⁸⁰

Taramakau Bridge is not listed with HNZPT.

¹⁸⁰ O'Connell (2016)



Figure 44: Taramakau Road and Rail Bridge, SH6.

Source: O'Connell (2016) p29

Bridge 135 over the Taieri River is listed as a Category II structure on the New Zealand Heritage list. The following information is extracted from the listing information given by HNZPT on their website:

The bridge over the Taieri River on the Hyde-Macraes Road was built in 1879. The bridge was constructed as the result of community agitation; the Taieri River could be dangerous in flood, and the upper Taieri area was isolated. The bridge provided safe crossing and a stable connection with the outside communities. The bridge is a testament to the design and work of the County Engineer Robert Browne... [It] has an iron lattice truss for the main span and short timber arch trusses at either end. The piers and abutments are stone. It was adapted to the site by the addition of a 30 ft (9.1m) span at each end, to give a total length of 160ft (48.7m). The deck is 30 ft (9.1m) above water level ... [and] remains a notable landmark ... According to historian Janet Cowan, the iron truss was fabricated in Dunedin. The bridge has been strengthened and some of the decking replaced since its construction.¹⁸¹

Bridge 135 exhibits some structural elements similar to the Beaumont Bridge; however, the two structures are quite different in size and design.

¹⁸¹ HNZPT (nd) www.heritage.org.nz

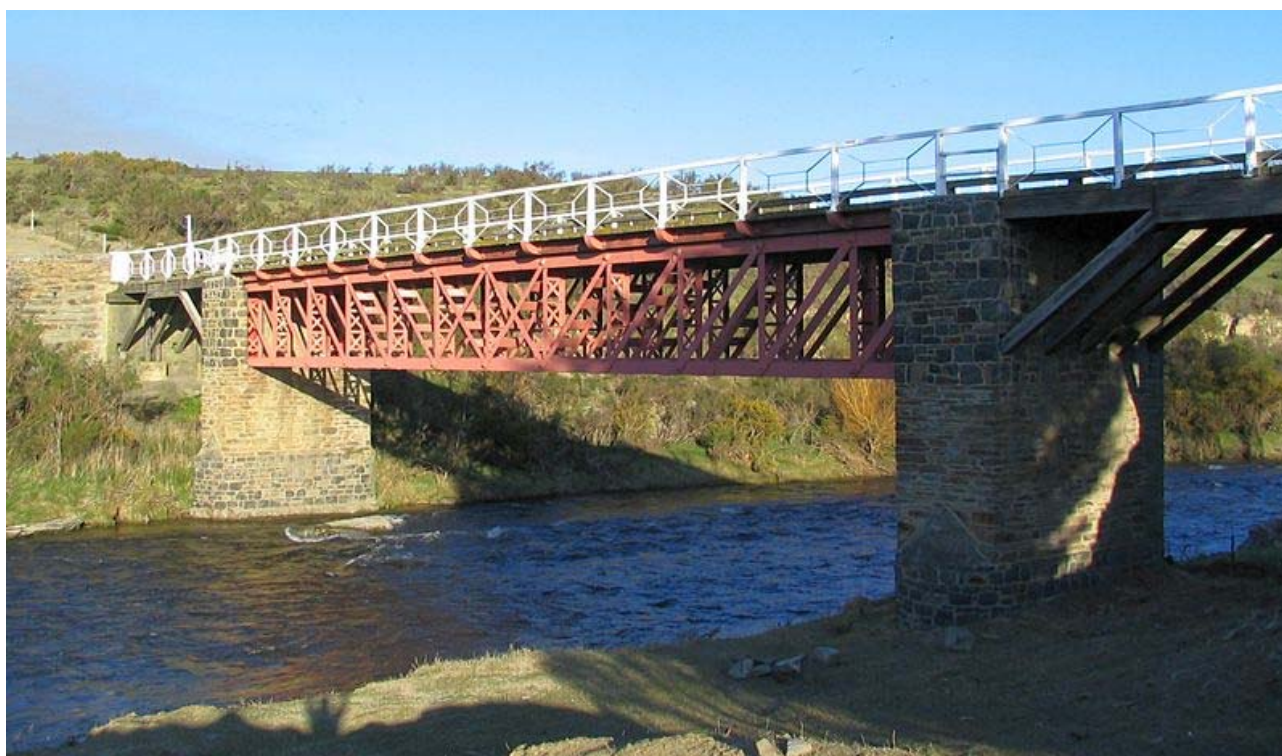

Figure 45: Bridge 135 across the Taieri River on Hyde-Macraes Rd.

Source: commons.wikimedia.org

These comparisons clearly demonstrate that the Beaumont Bridge one of the only remaining, and certainly the oldest, bridge of its type in New Zealand and is therefore unique in a local, regional and national context.

3.2.9 Vulnerability

The structure is vulnerable to deterioration or destruction or is it threatened by adjacent activities.

Over the course of 130 years of life, the Beaumont Bridge has withstood harsh environmental conditions and severe weather events including major floods; and has continued – albeit with regular inspections and maintenance – to stand up to traffic loads and use well beyond that for which it was designed. This is a testament to the quality of the design and materials, and resilience of the structure. However, it is clear that the current use of the bridge leaves it vulnerable to rapid deterioration.

In this respect, the Beaumont Bridge is also vulnerable to destruction resulting from replacement – whether this be as a direct result of demolition to construct a new bridge in its place; or as a result of the bridge being superseded and becoming redundant. It is therefore necessary to consider how future development can be carried out to address the vulnerability of this significant structure.

3.3 Methodology for Assessing Fabric Significance

3.3.1 Degree of Significance

To assess the degree of each significance associated with the fabric of the Beaumont Bridge, the following graduated scale is used:

Exceptional Significance (A)

The element has a primary role in understanding the heritage significance of the place.

High Significance (B)

The element has a secondary role in understanding the heritage significance of the place.

Moderate Significance (C)

The element plays a minor role in understanding the heritage significance of the place.

Little or No Significance (N)

The element makes little or no contribution in understanding the significance of the place, but is not intrusive or negative.

Intrusive (I)

The element is unsympathetic to, and has an adverse effect on, the heritage significance of the place.

3.3.2 Degree of Authenticity

As defined by the ICOMOS NZ Charter, “authenticity” refers to the credibility or truthfulness of the surviving evidence and knowledge of the cultural heritage value of a place. Assessment of authenticity is based on identification and analysis of the evidence and knowledge gathered in this Conservation Plan.

Similar to the degree of significance, the levels of authenticity are assessed using the following graduated scale:

Exceptional Authenticity

The element is known to be original and/or provides exceptionally credible or truthful evidence of cultural heritage values through form, fabric, technology, use or setting.

High Authenticity

The element is known to be historic and/or contributes to credible or truthful evidence of cultural heritage values through form, fabric, technology, use or setting.

Some Authenticity

The element is recent fabric and/or makes a limited contribution evidence of cultural heritage values of the structure in its form, fabric, technology, use or setting.

Little or No Authenticity

The element is recent fabric and/or makes no contribution to evidence of cultural heritage values of the structure in its form, fabric, technology, use or setting.

3.4 Assessment of Fabric Significance

An assessment of significance and authenticity of the fabric of the Beaumont Bridge is provided in Table 1.

Table 1: Cultural Heritage Significance of Beaumont Bridge

Element	Sig.	Reason	Auth.	Reason
Concrete piers and abutments	A	These elements are representative of the original design of the bridge. While arguably not as recognisable or technologically interesting as the superstructure, these elements play a primary role in understanding the significance of the bridge.	Exceptional	The concrete piers and abutments are effectively unchanged since their construction, with the exception of some minor alterations to substructural junctions. The piers remain in good condition; however the abutments, particularly the west abutment, are in a poor state of repair. Despite this, they continue to provide exceptionally credible evidence of the value of the structure.
Cast iron lattice girders, transoms, tie backs, and horizontal cross braces	A	These elements are the most recognisable and are of the greatest technological interest, therefore playing a primary role in understanding the significance of the structure.	Exceptional	Although repairs have been made to the ironwork, especially in recent years, these have been carried out with a reasonable level of sympathy to the original design and these elements continue to provide exceptionally credible evidence of the value of the structure.
King post trusses strengthening transoms	B	These elements are part of the history of the structure and play a role in understanding how it has been impacted by its use in the course of its life and therefore play an important role in understanding the significance of the structure.	Some	When considered in relation to the life of the bridge, these elements are recent fabric that alter its design and appearance. However, they are evidence of the ways in which the original form of the bridge has been challenged by increased use.
Timber bearers	B	Though it is understood that the original bearers have been replaced, the size and material (timber) replicates the original and these elements continue to	High	Documentary research indicates that bearers have been replaced over the lifetime of the bridge, but the extent of this replacement is unknown. However, these elements

Element	Sig.	Reason	Auth.	Reason
		play a role in understanding the significance of the structure.		continue to contribute credible evidence of the values associated with the structure through their form.
Timber decking and decking surface	N	The deck has been continuously altered and changed over the life of the bridge and does not play a particular role in understanding the significance of the structure other than to allow ongoing use.	Little	Documentary research indicates that the deck has been altered or replaced several times over the lifetime of the bridge.

3.5 Statement of Significance

Opening in 1887, the Beaumont Bridge was one of the first bridges with a wrought iron superstructure fabricated in New Zealand. Erected in the location of a punt that formed part of a vital access route into the Upper Clutha, in place of an earlier bridge that had washed away, the Beaumont Bridge has exceptional historic value that is intrinsically tied to the development of the Beaumont settlement. This historic value is heightened by connections to prominent PWD engineers and contractors who were influential across the country. While the structure is simple, it is well executed, and retains much of its original fabric. Where additions or repairs have been made, these have been carried out with sympathy to the original design, and have become an important part of the extant structure which has high architectural significance. At 130 years old, and believed to be the oldest road bridge of its kind remaining in New Zealand, the Beaumont Bridge is a vital contributor to our national engineering history, and has the potential, through further investigation and interpretive material, to be a source of greater archaeological understanding of the area as well as public education.

4 Future Use Considerations

4.1 Statutory Requirements

4.1.1 Clutha District Plan

The primary piece of legislation currently governing the future management of the Beaumont Bridge is the operative Clutha District Plan. Issues, objectives and policies regarding the identification, management and protection of heritage items are identified in Chapter 3.5 of the Plan. This chapter identifies that poorly executed modification or demolition of significant historic buildings, structures, precincts and streetscapes has occurred as a result of a general lack of awareness and appreciation of historic values leading to a loss of cultural heritage within the district.¹⁸² To prevent this from continuing to occur, Section 3.5.3 sets out objectives and policies to guide the use and development of built heritage, including:¹⁸³

- Policy HER.4 To conserve the heritage values of those buildings and structures, identified in the Register of Heritage Items (given in Table 13.1 of the Plan)
- Policy HER.7 To encourage the retention, preservation and reuse of the District's built heritage
- Policy HER.8 To protect significant cultural heritage items which are not protected by the provisions of the Historic Places Act 1993

Buildings and structures included in the Plan's Register of Heritage Items, these objectives and policies are implemented through Rule HER.1 set out in Section 3.5.4 as follows:

- (i) **Redecoration or restoration of any original features, details or fabrics is a permitted activity**¹⁸⁴ provided it is carried out in the same manner and design and with similar materials to those originally used and does not detract from the historical character of the registered item.
- (ii) **Any alteration or addition proposed will first be considered as a non-notified restricted discretionary activity.** Council shall restrict the exercise of its discretion to matters of design, materials and colours used and any effect on the special character of the registered item. The written consent of the New Zealand Historic Places Trust [now Heritage New Zealand Pouhere Taonga] is required.¹⁸⁵
- (iii) **Works which may modify, destroy or detract from the character of a registered building or structure shall be considered as a discretionary activity** which Council shall both, publicly notify and serve notice upon the New Zealand Historic Places Trust [now Heritage New Zealand Pouhere Taonga] and other such interested groups as it sees fit.

As the Beaumont Bridge forms part of SH8, it is also a Designated Site under the Clutha District Plan. As such, an Outline Plan amendment, and not a Resource Consent, will be required for works where the use of the bridge remains the same – that is, if the bridge is to remain open to road

¹⁸² Clutha District Plan, Section 3.5.2

¹⁸³ Clutha District Plan, Section 3.5.2

¹⁸⁴ Permitted Activities do not require a Resource Consent.

¹⁸⁵ It would appear from the wording of this Section that written consent of HNZPT is required regardless of whether or not the item is included on the New Zealand Heritage List.

traffic. However, under Section 176A (3) (f) of the Council is required to consider under ‘other matters’ when assessing an Outline Plan application; and one of these other matters is heritage. It is therefore likely that the Council will consider an Outline Plan application using the same criteria as it would in assessing an application for Resource Consent. Where the use of the bridge is to change, a Resource Consent may be required. This requires further investigation and advice from an appropriately qualified planner.

4.1.2 Building Act 2004

The Building Act 2004 regulates all buildings and structures to safeguard the health, safety, and amenity of people, facilitate efficient energy use, and to protect property from damage. The key regulatory tool is the New Zealand Building Code (the Code).

For the purposes of the Building Code, “buildings” are classified according to type in Clause A1. Bridges are considered to be ancillary buildings, defined as:

a *building* or use not for human habitation and which may be exempted from some amenity provisions, but which are required to comply with structural and safety-related aspects of the *building code*.¹⁸⁶

In administering its functions under the Building Act, a territorial authority can adopt a flexible approach to heritage structures. The Act states that the territorial authority shall have due regard to any special historical or cultural value of a building.

Currently the Building Act links with the HNZPTA through Project Information Memoranda (PIMs) and building consent processes. These links provide an ‘early warning system’ to enable HNZPT to fulfil its statutory function to advocate for the protection of historical and cultural heritage in the public interest.¹⁸⁷

4.1.3 Heritage New Zealand Pouhere Taonga Act 2014

The HNZPTA:

... makes it unlawful for any person to modify or destroy, or cause to be modified or destroyed, the whole or any part of an archaeological site without the prior authority of Heritage New Zealand. This is the case regardless of whether the land on which the site is located is designated, or the activity is permitted under the District or Regional Plan or a resource or building consent has been granted. The Act provides for substantial penalties for unauthorised destruction or modification.¹⁸⁸

Any person wishing to undertake work that may damage, modify or destroy an archaeological site must first obtain an authority from the Heritage New Zealand for that work.

Archaeological Site is defined in Section 6 of the Act as

any place in New Zealand, including any building or structure (or part of a building or structure), that—

¹⁸⁶ NZBC A1 8.0

¹⁸⁷ www.historic.org.nz

¹⁸⁸ www.historic.org.nz

- i. was associated with human activity that occurred before 1900 or is the site of the wreck of any vessel where the wreck occurred before 1900; and
- ii. provides or may provide, through investigation by archaeological methods, evidence relating to the history of New Zealand.

Under this definition, works affecting the Beaumont Bridge, and much of the wider Beaumont area, will require an Archaeological Authority. This requires further investigation and advice from an appropriately qualified archaeologist.

4.2 Non-Statutory Requirements

4.2.1 The ICOMOS New Zealand Charter for the Conservation of Places of Cultural Heritage Value (Revised 2010)

The ICOMOS NZ Charter provides a set of policies to guide the conservation and adaptation of places of cultural heritage value. The Charter is provided in full in Appendix 1. In relation to the Beaumont Bridge, the following policies are of particular relevance:

- Policy 5: The removal or obscuring of any physical evidence of any period or activity should be minimised, and should be explicitly justified where it does occur.
- Policy 6: Intervention should be the minimum necessary to ensure the retention of tangible and intangible values and the continuation of uses integral to those values. The removal of fabric or the alteration of features and spaces that have cultural heritage value should be avoided.
- Policy 9: Where the setting of a place is integral to its cultural heritage value, that setting should be conserved with the place itself.
- Policy 18:
 - i. Stabilisation
Processes of decay should be slowed by providing treatment or support.
 - ii. Maintenance
A place of cultural heritage value should be maintained regularly. Maintenance should be carried out according to a plan or work programme.
 - iii. Repair
Repair of a place of cultural heritage value should utilise matching or similar materials... Traditional methods and materials should be given preference in conservation work. Repair of a technically higher standard than that achieved with the existing materials or construction practices may be justified only where the stability or life expectancy of the site or material is increased, where the new material is compatible with the old, and where the cultural heritage value is not diminished.
- Policy 19:
 - ii. Removal
Occasionally, existing fabric may need to be permanently removed from a place. This may be for reasons of advanced decay, or loss of structural integrity, or because particular fabric has been identified in a conservation plan as detracting from the cultural heritage value of the place.

- Policy 21: The conservation of a place of cultural heritage value is usually facilitated by the place serving a useful purpose. Proposals for adaptation of a place may arise from maintaining its continuing use, or from a proposed change of use.
- Policy 23: Where appropriate, interpretation should [be put in place to] assist the understanding of tangible and intangible values of a place which may not be readily perceived, such as the sequence of construction and change, and the meanings and associations of the place for connected people. Any interpretation should respect the cultural heritage value of a place.
- Policy 24: Places of cultural heritage value may be vulnerable to natural disasters such as flood, storm, or earthquake; or to humanly induced threats and risks such as those arising from earthworks, subdivision and development, buildings works, or wilful damage or neglect. In order to safeguard cultural heritage value, planning for risk mitigation and emergency management is necessary.

4.2.2 New Zealand Transport Agency Bridge Manual

The NZ Transport Agency Bridge Manual sets out the criteria for the design and evaluation of bridges, including bridges of reinforced concrete construction carrying pedestrian traffic.¹⁸⁹ It includes performance specifications for durability, structural performance, access and safety.

¹⁸⁹ NZ Transport Agency (2016b) p1-2

5 Conclusion and Recommendations

The Beaumont Bridge has high archaeological, aesthetic and cultural value; and exceptional historic, contextual, and technological value. The settlement of Beaumont also has high cultural, archaeological, historic and social value.

It is understood that the Detailed Business Case for which this Heritage Significance Assessment has been prepared will focus on the likelihood that a new road bridge will be constructed, and the highway approaches realigned to suit.¹⁹⁰ Considering this likely outcome, the following recommendations are made:

- The Beaumont Bridge should be retained. While demolition of the Beaumont Bridge is not prohibited under current legislation, the exceptional significance and rarity of the structure mean that demolition should be ruled out as an option.
- A new use should be found for the Beaumont Bridge. It is evident that the ongoing maintenance required to maintain current use of the bridge as a roadway, particularly for HPMVs, is not sustainable. However, in removing the bridge from the state highway network, it is important that the bridge continue to be used to ensure that it does not become redundant. Options for adaptive reuse of the bridge should consider the various heritage significances of the extant structure. The bridge currently forms part of the Clutha Gold Trail which connects with the Otago Central Rail Trail and the Roxburgh Gorge Trail. These trails are well patronised and include a number of historic bridges that have been adapted for cycling. It is therefore considered that the most viable option for continuing use of the bridge is as a pedestrian and cycle way. This use would also be consistent with the historic origins of the bridge, which was designed to allow pedestrians and non-motorised transport to cross.
- Repair works necessary to make the bridge suitable for the selected alternative use without the need for permanent scaffolding should be carried out, including repair and restoration of the concrete abutments. A complete clean of the structure is also recommended.
- Replacement options for the Beaumont Bridge should consider the heritage significance of both the existing bridge and the Beaumont settlement. The design of any new bridge that is within proximity of the existing bridge should take into account the setting of the existing bridge as well as the layout of the existing township.
- A full and comprehensive Conservation Management Plan for the Beaumont Bridge should be prepared. This Plan should provide guidance on how to manage and maintain the bridge, and be prepared by an appropriately qualified heritage consultant for any and all proposed works that will affect the bridge.
- A full and comprehensive Archaeological Assessment should be prepared by an appropriately qualified archaeologist for any works to or around the bridge, or in the Beaumont area; this will be required for any Archaeological Authority Application.

¹⁹⁰ DBC RFT Section 5

Bibliography & References

Published Texts

Central Otago District Council (2011) *Clutha River/Mata-au Plan (including Lakes Dunstan and Roxburgh)*. Otago: Central Otago District Council

Dunedin Family History Group (nd) 'Clutha'. URL: www.dunedinfamilyhistory.co.nz/south-otago/

Frazer, R. (updated 2013) 'Chalmers, Nathanael' in *The Dictionary of New Zealand Biography, Te Ara - the Encyclopaedia of New Zealand*. URL: www.teara.govt.nz/en/biographies/1c11/chalmers-nathanael

Hall-Jones, J. (updated 2014) 'Thomson, John Turnbull' in *The Dictionary of New Zealand Biography, Te Ara - the Encyclopaedia of New Zealand*. URL: www.teara.govt.nz/en/biographies/1t97/thomson-john-turnbull

Hands off Beaumont (nd) 'Our History'. URL: handsoffbeaumont.blogspot.co.nz/2009/11/our-history

Heritage New Zealand Pouhere Taonga (nd) 'List Entry Information for Bridge, Hyde-Macraes Road, Hyde'. URL: www.heritage.org.nz/the-list/details/2251

ICOMOS New Zealand (2010) *ICOMOS New Zealand Charter for the Conservation of Places of Cultural Heritage Value, Revised 2010*

IPENZ (nd a) 'Heritage Register'. URL: www.ipenz.org.nz/heritage/

IPENZ (nd b) 'Beaumont Bridge, Clutha River'. URL: www.ipenz.org.nz/heritage/itemdetail.cfm?itemid=131

Lowe, P. (updated 2012) 'Anderson, John' in *The Dictionary of New Zealand Biography, Te Ara - the Encyclopaedia of New Zealand*. URL: www.TeAra.govt.nz/en/biographies/1a6/anderson-john

McLintock, A. H. (ed.) (1966) 'Clutha River', in *An Encyclopaedia of New Zealand, Te Ara - the Encyclopaedia of New Zealand*. URL: www.teara.govt.nz/en/1966/clutha-river

Mighty Clutha (nd) 'A Brief History'. URL: mightyclutha.blogspot.co.nz/2009/01/born-in-earthquake.html

NZ Transport Agency (2015) *Historic Heritage Impact Assessment Guide for State Highway Projects*. Wellington: NZ Transport Agency

NZ Transport Agency (2016b) *Bridge Manual (manual number SP/M/022)*. Wellington: NZ Transport Agency

Orr, K. W. (updated 2012) 'Blackett, John' in *The Dictionary of New Zealand Biography, Te Ara - the Encyclopaedia of New Zealand*. URL: www.TeAra.govt.nz/en/biographies/1b23/blackett-john

Save the Clutha (nd) 'Heritage'. URL: savetheclutha.blogspot.co.nz/2009/05/heritage.html

Thornton, G. (2001) *Bridging the Gap, Early Bridges in New Zealand 1830-1939*. Auckland: Reed Books

Waite, F. (1940) *Port Molyneux: The Story of Maori and Pakeha in South Otago*. Otago: Clutha County Council

Walrond, C. (nd) 'Gold and gold mining - Dredging' in *Te Ara - the Encyclopaedia of New Zealand*. URL: www.teara.govt.nz/en/gold-and-gold-mining/page-8

Webster, A. H. H. (1948) *Teviot Tapestry: A History of the Roxburgh-Millers Flat District*. Otago: Otago Centennial Historical Publications

Williams, T. (updated 2013) 'Blair, William Newsham' in *The Dictionary of New Zealand Biography, Te Ara - the Encyclopaedia of New Zealand*. URL: www.TeAra.govt.nz/en/biographies/2b27/blair-william-newsham

Media Releases

NZ Transport Agency (2009) 'Replacement of Beaumont Bridge to be investigated'. URL: www.nzta.govt.nz/media-releases/replacement-of-beaumont-bridge-to-be-investigated/

NZ Transport Agency (2010) 'Traffic signals take control at Beaumont Bridge'. URL: www.nzta.govt.nz/media-releases/traffic-signals-take-control-at-beaumont-bridge/

NZ Transport Agency (2014) 'Night time traffic delays at the Beaumont Bridge'. URL: www.nzta.govt.nz/media-releases/night-time-traffic-delays-at-the-beaumont-bridge/

NZ Transport Agency (2015a) 'Night time closures extended at Beaumont'. URL: www.nzta.govt.nz/media-releases/night-time-closures-extended-at-beaumont-bridge/

NZ Transport Agency (2015a) 'Evening/ overnight delays Beaumont Bridge, SH8, Otago – after Labour Weekend'. URL: www.nzta.govt.nz/media-releases/evening-overnight-delays-beaumont-bridge-sh8-otago-after-labour-weekend/

NZ Transport Agency (2016) 'Beaumont Bridge night closures in March, open on the hour'. URL: www.nzta.govt.nz/media-releases/beaumont-bridge-night-closures-in-march-open-on-the-hour/

Unpublished Documents

Brooks, E., Jacomb, C. and Walter, R. (2010) *Archaeological Baseline Survey and Management Plan of the Clutha Mata-au River*. Unpublished Report prepared by Southern Pacific Archaeological Research for the New Zealand Historic Places Trust

New Zealand Transport Agency (2016a) *Beaumont Bridge Replacement: Detailed Business Case*. Request for Tender document issued by the NZ Transport Agency

O'Connell, T. J. (2016) *Archaeological Assessment: Taramakau Road Bridge Upgrades*. Unpublished Report prepared by Opus International Consultants

Opus International Consultants (2015a) *SH8 Beaumont Bridge HPMV Strengthening*. PowerPoint presentation prepared by Opus International Consultants for the NZ Transport Agency

Opus International Consultants (2015b) *SH8 Beaumont Bridge Phase 3 Strengthening*. Drawings prepared by Opus International Consultants for the NZ Transport Agency

Archive Records

Contract for Superstructure of the Beaumont Bridge
PWD 12762, Archives New Zealand Ref W5 268

Newspaper Articles

Bruce Herald, 5 February 1868	Tuapeka Times, 27 March 1869
Bruce Herald, 17 June 1873	Tuapeka Times, 23 June 1870
Bruce Herald, 13 October 1874	Tuapeka Times, 25 April 1872
Bruce Herald, 7 July 1874	Tuapeka Times, 21 August 1873
Bruce Herald, 12 October 1875	Tuapeka Times, 27 June 1874
Bruce Herald, 14 March 1876	Tuapeka Times, 23 September 1874
Bruce Herald, 27 September 1878	Tuapeka Times, 28 November 1874
	Tuapeka Times, 19 August 1874
Clutha Leader, 18 March 1887	Tuapeka Times, 4 November 1874
	Tuapeka Times, 25 November 1874
Evening Star, 20 May 1873	Tuapeka Times, 28 November 1874
Evening Star, 27 September 1878	Tuapeka Times, 1 November 1876
Evening Star, 30 September 1878	Tuapeka Times, 6 January 1877
Evening Star, 6 October 1883	Tuapeka Times, 10 March 1877
Evening Star, 31 March 1897	Tuapeka Times, 30 November 1878
Evening Star, 7 July 1897	Tuapeka Times, 2 March 1878
North Otago Times, 18 October 1912	Tuapeka Times, 12 June 1878
	Tuapeka Times, 28 September 1878
Mt Bengier Mail, 29 November 1911	Tuapeka Times, 30 November 1878
Mt Bengier Mail, 21 January 1914	Tuapeka Times, 31 March 1880
Mt Bengier Mail, 17 January 1917	Tuapeka Times, 8 October 1879
Mt Bengier Mail, 13 April 1921	Tuapeka Times, 13 December 1879
Mt Bengier Mail, 16 November 1921	Tuapeka Times, 17 December 1879
Mt Bengier Mail, 26 April 1922	Tuapeka Times, 17 January 1880
Mt Bengier Mail, 28 June 1922	Tuapeka Times, 24 March 1880
Mt Bengier Mail, 17 December 1924	Tuapeka Times, 17 March 1880
Mt Bengier Mail, 3 June 1925	Tuapeka Times, 10 April 1880
Mt Bengier Mail, 18 August 1926	Tuapeka Times, 15 May 1880
Mt Bengier Mail, 15 October 1930	Tuapeka Times, 9 June 1880
Mt Bengier Mail, 3 October 1934	Tuapeka Times, 10 July 1880
Mt Bengier Mail, 17 July 1935	Tuapeka Times, 12 February 1881
	Tuapeka Times, 9 April 1881
Oamaru Mail, 30 September 1878	Tuapeka Times, 20 July 1881
	Tuapeka Times, 20 July 1881
Otago Daily Times, 20 October 1864	Tuapeka Times, 19 October 1881
Otago Daily Times, 24 February 1870	Tuapeka Times, 17 December 1881
Otago Daily Times, 11 December 1874	Tuapeka Times, 18 April 1883
Otago Daily Times, 13 May 1878	Tuapeka Times, 25 April 1883
Otago Daily Times, 3 December 1879	Tuapeka Times, 18 July 1883
Otago Daily Times, 6 March 1882	Tuapeka Times, 26 September 1883
Otago Daily Times, 13 May 1885	Tuapeka Times, 21 November 1883
Otago Daily Times, 15 October 1886	Tuapeka Times, 24 November 1883
Otago Daily Times, 25 October 1886	Tuapeka Times, 12 December 1883
Otago Daily Times, 28 October 1886	Tuapeka Times, 15 March 1884

Otago Daily Times, 9 March 1887
Otago Daily Times, 30 June 1919
Otago Daily Times, 11 July 1921
Otago Daily Times, 13 October 1924
Otago Daily Times, 29 October 1926
Otago Daily Times, 25 November 1930
Otago Daily Times, 31 October 2011
Otago Daily Times, 6 October 2016

Otago Witness, 13 December 1879
Otago Witness, 16 January 1886
Otago Witness, 17 September 1886
Otago Witness, 29 April 1887
Otago Witness, 30 July 1896
Otago Witness, 19 August 1897
Otago Witness, 22 April 1903
Otago Witness, 6 December 1905
Otago Witness, 24 January 1906

Tuapeka Times, 14 June 1884
Tuapeka Times, 25 June 1884
Tuapeka Times, 9 August 1884
Tuapeka Times, 8 November 1884
Tuapeka Times, 1 April 1885
Tuapeka Times, 22 August 1885
Tuapeka Times, 23 December 1885
Tuapeka Times, 13 March 1886
Tuapeka Times, 26 May 1886
Tuapeka Times, 11 August 1886
Tuapeka Times, 24 November 1886
Tuapeka Times, 11 December 1886
Tuapeka Times, 16 February 1887
Tuapeka Times, 9 March 1887
Tuapeka Times, 27 April 1887
Tuapeka Times, 9 July 1887
Tuapeka Times, 3 September 1887
Tuapeka Times, 14 January 1888
Tuapeka Times, 30 October 1895
Tuapeka Times, 5 September 1896
Tuapeka Times, 11 October 1902
Tuapeka Times, 12 January 1907
Tuapeka Times, 12 June 1920

Appendix 1

ICOMOS New Zealand Charter for the Conservation of Places of Cultural Heritage Value
(Revised 2010)

ICOMOS New Zealand Charter

for the Conservation of Places of Cultural Heritage Value

Revised 2010

Preamble

New Zealand retains a unique assemblage of **places of cultural heritage value** relating to its indigenous and more recent peoples. These areas, **cultural landscapes** and features, buildings and **structures**, gardens, archaeological sites, traditional sites, monuments, and sacred **places** are treasures of distinctive value that have accrued meanings over time. New Zealand shares a general responsibility with the rest of humanity to safeguard its cultural heritage **places** for present and future generations. More specifically, the people of New Zealand have particular ways of perceiving, relating to, and conserving their cultural heritage **places**.

Following the spirit of the International Charter for the Conservation and Restoration of Monuments and Sites (the Venice Charter - 1964), this charter sets out principles to guide the **conservation of places of cultural heritage value** in New Zealand. It is a statement of professional principles for members of ICOMOS New Zealand.

This charter is also intended to guide all those involved in the various aspects of **conservation** work, including owners, guardians, managers, developers, planners, architects, engineers, craftspeople and those in the construction trades, heritage practitioners and advisors, and local and central government authorities. It offers guidance for communities, organisations, and individuals involved with the **conservation** and management of cultural heritage **places**.

This charter should be made an integral part of statutory or regulatory heritage management policies or plans, and should provide support for decision makers in statutory or regulatory processes.

Each article of this charter must be read in the light of all the others. Words in bold in the text are defined in the definitions section of this charter.

This revised charter was adopted by the New Zealand National Committee of the International Council on Monuments and Sites at its meeting on 4 September 2010.

Purpose of conservation

1. The purpose of conservation

The purpose of **conservation** is to care for **places of cultural heritage value**.

In general, such **places**:

- (i) have lasting values and can be appreciated in their own right;
- (ii) inform us about the past and the cultures of those who came before us;
- (iii) provide tangible evidence of the continuity between past, present, and future;
- (iv) underpin and reinforce community identity and relationships to ancestors and the land; and
- (v) provide a measure against which the achievements of the present can be compared.

It is the purpose of **conservation** to retain and reveal such values, and to support the ongoing meanings and functions of **places** of **cultural heritage value**, in the interests of present and future generations.

Conservation principles

2. Understanding cultural heritage value

Conservation of a **place** should be based on an understanding and appreciation of all aspects of its **cultural heritage value**, both **tangible** and **intangible**. All available forms of knowledge and evidence provide the means of understanding a **place** and its **cultural heritage value** and **cultural heritage significance**. **Cultural heritage value** should be understood through consultation with **connected people**, systematic documentary and oral research, physical investigation and **recording** of the **place**, and other relevant methods.

All relevant **cultural heritage values** should be recognised, respected, and, where appropriate, revealed, including values which differ, conflict, or compete.

The policy for managing all aspects of a **place**, including its **conservation** and its **use**, and the implementation of the policy, must be based on an understanding of its **cultural heritage value**.

3. Indigenous cultural heritage

The indigenous cultural heritage of **tangata whenua** relates to **whanau**, **hapu**, and **iwi** groups. It shapes identity and enhances well-being, and it has particular cultural meanings and values for the present, and associations with those who have gone before. Indigenous cultural heritage brings with it responsibilities of guardianship and the practical application and passing on of associated knowledge, traditional skills, and practices.

The Treaty of Waitangi is the founding document of our nation. Article 2 of the Treaty recognises and guarantees the protection of **tino rangatiratanga**, and so empowers **kaitiakitanga** as customary trusteeship to be exercised by **tangata whenua**. This customary trusteeship is exercised over their **taonga**, such as sacred and traditional **places**, built heritage, traditional practices, and other cultural heritage resources. This obligation extends beyond current legal ownership wherever such cultural heritage exists.

Particular **matauranga**, or knowledge of cultural heritage meaning, value, and practice, is associated with **places**. **Matauranga** is sustained and transmitted through oral, written, and physical forms determined by **tangata whenua**. The **conservation** of such **places** is therefore conditional on decisions made in associated **tangata whenua** communities, and should proceed only in this context. In particular, protocols of access, authority, ritual, and practice are determined at a local level and should be respected.

4. Planning for conservation

Conservation should be subject to prior documented assessment and planning.

All **conservation** work should be based on a **conservation plan** which identifies the **cultural heritage value** and **cultural heritage significance** of the **place**, the **conservation** policies, and the extent of the recommended works.

The **conservation plan** should give the highest priority to the **authenticity** and **integrity** of the **place**.

Other guiding documents such as, but not limited to, management plans, cyclical **maintenance** plans, specifications for **conservation** work, interpretation plans, risk mitigation plans, or emergency plans should be guided by a **conservation plan**.

5. Respect for surviving evidence and knowledge

Conservation maintains and reveals the **authenticity** and **integrity** of a **place**, and involves the least possible loss of **fabric** or evidence of **cultural heritage value**. Respect for all forms of knowledge and existing evidence, of both **tangible** and **intangible values**, is essential to the **authenticity** and **integrity** of the **place**.

Conservation recognises the evidence of time and the contributions of all periods. The **conservation** of a **place** should identify and respect all aspects of its **cultural heritage value** without unwarranted emphasis on any one value at the expense of others.

The removal or obscuring of any physical evidence of any period or activity should be minimised, and should be explicitly justified where it does occur. The **fabric** of a particular period or activity may be obscured or removed if assessment shows that its removal would not diminish the **cultural heritage value** of the **place**.

In **conservation**, evidence of the functions and intangible meanings of **places** of **cultural heritage value** should be respected.

6. Minimum intervention

Work undertaken at a **place** of **cultural heritage value** should involve the least degree of **intervention** consistent with **conservation** and the principles of this charter.

Intervention should be the minimum necessary to ensure the retention of **tangible** and **intangible values** and the continuation of **uses** integral to those values. The removal of **fabric** or the alteration of features and spaces that have **cultural heritage value** should be avoided.

7. Physical investigation

Physical investigation of a **place** provides primary evidence that cannot be gained from any other source. Physical investigation should be carried out according to currently accepted professional standards, and should be documented through systematic **recording**.

Invasive investigation of **fabric** of any period should be carried out only where knowledge may be significantly extended, or where it is necessary to establish the existence of **fabric** of **cultural heritage value**, or where it is necessary for **conservation** work, or where such **fabric** is about to be damaged or destroyed or made inaccessible. The extent of invasive investigation should minimise the disturbance of significant **fabric**.

8. Use

The **conservation** of a **place** of **cultural heritage value** is usually facilitated by the **place** serving a useful purpose.

Where the **use** of a **place** is integral to its **cultural heritage value**, that **use** should be retained.

Where a change of **use** is proposed, the new **use** should be compatible with the **cultural heritage value** of the **place**, and should have little or no adverse effect on the **cultural heritage value**.

9. Setting

Where the **setting** of a **place** is integral to its **cultural heritage value**, that **setting** should be conserved with the **place** itself. If the **setting** no longer contributes to the **cultural heritage value** of the **place**, and if **reconstruction** of the **setting** can be justified, any **reconstruction** of the **setting** should be based on an understanding of all aspects of the **cultural heritage value** of the **place**.

10. Relocation

The on-going association of a **structure** or feature of **cultural heritage value** with its location, site, curtilage, and **setting** is essential to its **authenticity** and **integrity**. Therefore, a **structure** or feature of **cultural heritage value** should remain on its original site.

Relocation of a **structure** or feature of **cultural heritage value**, where its removal is required in order to clear its site for a different purpose or construction, or where its removal is required to enable its **use** on a different site, is not a desirable outcome and is not a **conservation** process.

In exceptional circumstances, a **structure** of **cultural heritage value** may be relocated if its current site is in imminent danger, and if all other means of retaining the **structure** in its current location have been exhausted. In this event, the new location should provide a **setting** compatible with the **cultural heritage value** of the **structure**.

11. Documentation and archiving

The **cultural heritage value** and **cultural heritage significance** of a **place**, and all aspects of its **conservation**, should be fully documented to ensure that this information is available to present and future generations.

Documentation includes information about all changes to the **place** and any decisions made during the **conservation** process.

Documentation should be carried out to archival standards to maximise the longevity of the record, and should be placed in an appropriate archival repository.

Documentation should be made available to **connected people** and other interested parties. Where reasons for confidentiality exist, such as security, privacy, or cultural appropriateness, some information may not always be publicly accessible.

12. Recording

Evidence provided by the **fabric** of a **place** should be identified and understood through systematic research, **recording**, and analysis.

Recording is an essential part of the physical investigation of a **place**. It informs and guides the **conservation** process and its planning. Systematic **recording** should occur prior to, during, and

following any **intervention**. It should include the **recording** of new evidence revealed, and any **fabric** obscured or removed.

Recording of the changes to a **place** should continue throughout its life.

13. Fixtures, fittings, and contents

Fixtures, fittings, and **contents** that are integral to the **cultural heritage value** of a **place** should be retained and conserved with the **place**. Such fixtures, fittings, and **contents** may include carving, painting, weaving, stained glass, wallpaper, surface decoration, works of art, equipment and machinery, furniture, and personal belongings.

Conservation of any such material should involve specialist **conservation** expertise appropriate to the material. Where it is necessary to remove any such material, it should be recorded, retained, and protected, until such time as it can be reinstated.

Conservation processes and practice

14. Conservation plans

A **conservation plan**, based on the principles of this charter, should:

- (i) be based on a comprehensive understanding of the **cultural heritage value** of the **place** and assessment of its **cultural heritage significance**;
- (ii) include an assessment of the **fabric** of the **place**, and its condition;
- (iii) give the highest priority to the **authenticity** and **integrity** of the **place**;
- (iv) include the entirety of the **place**, including the **setting**;
- (v) be prepared by objective professionals in appropriate disciplines;
- (vi) consider the needs, abilities, and resources of **connected people**;
- (vii) not be influenced by prior expectations of change or development;
- (viii) specify **conservation** policies to guide decision making and to guide any work to be undertaken;
- (ix) make recommendations for the **conservation** of the **place**; and
- (x) be regularly revised and kept up to date.

15. Conservation projects

Conservation projects should include the following:

- (i) consultation with interested parties and **connected people**, continuing throughout the project;
- (ii) opportunities for interested parties and **connected people** to contribute to and participate in the project;
- (iii) research into documentary and oral history, using all relevant sources and repositories of knowledge;
- (iv) physical investigation of the **place** as appropriate;
- (v) use of all appropriate methods of **recording**, such as written, drawn, and photographic;

- (vi) the preparation of a **conservation plan** which meets the principles of this charter;
- (vii) guidance on appropriate **use** of the **place**;
- (viii) the implementation of any planned **conservation work**; (ix) the **documentation** of the **conservation work** as it proceeds; and
- (x) where appropriate, the deposit of all records in an archival repository.

A **conservation** project must not be commenced until any required statutory authorisation has been granted.

16. Professional, trade, and craft skills

All aspects of **conservation** work should be planned, directed, supervised, and undertaken by people with appropriate **conservation** training and experience directly relevant to the project.

All **conservation** disciplines, arts, crafts, trades, and traditional skills and practices that are relevant to the project should be applied and promoted.

17. Degrees of intervention for conservation purposes

Following research, **recording**, assessment, and planning, **intervention** for **conservation** purposes may include, in increasing degrees of **intervention**:

- (i) **preservation**, through **stabilisation, maintenance, or repair**;
- (ii) **restoration**, through **reassembly, reinstatement, or removal**;
- (iii) **reconstruction**; and (iv) **adaptation**.

In many **conservation** projects a range of processes may be utilised. Where appropriate, **conservation** processes may be applied to individual parts or components of a **place** of **cultural heritage value**.

The extent of any **intervention** for **conservation** purposes should be guided by the **cultural heritage value** of a **place** and the policies for its management as identified in a **conservation plan**. Any **intervention** which would reduce or compromise **cultural heritage value** is undesirable and should not occur.

Preference should be given to the least degree of **intervention**, consistent with this charter.

Re-creation, meaning the conjectural **reconstruction** of a **structure** or **place**; replication, meaning to make a copy of an existing or former **structure** or **place**; or the construction of generalised representations of typical features or **structures**, are not **conservation** processes and are outside the scope of this charter.

18. Preservation

Preservation of a **place** involves as little **intervention** as possible, to ensure its long-term survival and the continuation of its **cultural heritage value**.

Preservation processes should not obscure or remove the patina of age, particularly where it contributes to the **authenticity** and **integrity** of the **place**, or where it contributes to the structural stability of materials.

i. Stabilisation

Processes of decay should be slowed by providing treatment or support.

ii. Maintenance

A **place of cultural heritage value** should be maintained regularly. **Maintenance** should be carried out according to a plan or work programme.

iii. Repair

Repair of a **place of cultural heritage value** should utilise matching or similar materials. Where it is necessary to employ new materials, they should be distinguishable by experts, and should be documented.

Traditional methods and materials should be given preference in **conservation** work.

Repair of a technically higher standard than that achieved with the existing materials or construction practices may be justified only where the stability or life expectancy of the site or material is increased, where the new material is compatible with the old, and where the **cultural heritage value** is not diminished.

19. Restoration

The process of **restoration** typically involves **reassembly** and **reinstatement**, and may involve the removal of accretions that detract from the **cultural heritage value** of a **place**.

Restoration is based on respect for existing **fabric**, and on the identification and analysis of all available evidence, so that the **cultural heritage value** of a **place** is recovered or revealed. **Restoration** should be carried out only if the **cultural heritage value** of the **place** is recovered or revealed by the process.

Restoration does not involve conjecture.

i. Reassembly and reinstatement

Reassembly uses existing material and, through the process of **reinstatement**, returns it to its former position. **Reassembly** is more likely to involve work on part of a **place** rather than the whole **place**.

ii. Removal

Occasionally, existing **fabric** may need to be permanently removed from a **place**. This may be for reasons of advanced decay, or loss of structural **integrity**, or because particular **fabric** has been identified in a **conservation plan** as detracting from the **cultural heritage value** of the **place**.

The **fabric** removed should be systematically **recorded** before and during its removal. In some cases it may be appropriate to store, on a long-term basis, material of evidential value that has been removed.

20. Reconstruction

Reconstruction is distinguished from **restoration** by the introduction of new material to replace material that has been lost.

Reconstruction is appropriate if it is essential to the function, **integrity**, **intangible value**, or understanding of a **place**, if sufficient physical and documentary evidence exists to minimise conjecture, and if surviving **cultural heritage value** is preserved.

Reconstructed elements should not usually constitute the majority of a **place** or **structure**.

21. Adaptation

The **conservation** of a **place** of **cultural heritage value** is usually facilitated by the **place** serving a useful purpose. Proposals for **adaptation** of a **place** may arise from maintaining its continuing **use**, or from a proposed change of **use**.

Alterations and additions may be acceptable where they are necessary for a **compatible use** of the **place**. Any change should be the minimum necessary, should be substantially reversible, and should have little or no adverse effect on the **cultural heritage value** of the **place**.

Any alterations or additions should be compatible with the original form and **fabric** of the **place**, and should avoid inappropriate or incompatible contrasts of form, scale, mass, colour, and material.

Adaptation should not dominate or substantially obscure the original form and **fabric**, and should not adversely affect the **setting** of a **place** of **cultural heritage value**. New work should complement the original form and **fabric**.

22. Non-intervention

In some circumstances, assessment of the **cultural heritage value** of a **place** may show that it is not desirable to undertake any **conservation intervention** at that time. This approach may be appropriate where undisturbed constancy of **intangible values**, such as the spiritual associations of a sacred **place**, may be more important than its physical attributes.

23. Interpretation

Interpretation actively enhances public understanding of all aspects of **places** of **cultural heritage value** and their **conservation**. Relevant cultural protocols are integral to that understanding, and should be identified and observed.

Where appropriate, interpretation should assist the understanding of **tangible** and **intangible values** of a **place** which may not be readily perceived, such as the sequence of construction and change, and the meanings and associations of the **place** for **connected people**.

Any interpretation should respect the **cultural heritage value** of a **place**. Interpretation methods should be appropriate to the **place**. Physical **interventions** for interpretation purposes should not detract from the experience of the **place**, and should not have an adverse effect on its **tangible** or **intangible values**.

24. Risk mitigation

Places of **cultural heritage value** may be vulnerable to natural disasters such as flood, storm, or earthquake; or to humanly induced threats and risks such as those arising from earthworks, subdivision and development, buildings works, or wilful damage or neglect. In order to safeguard **cultural heritage value**, planning for risk mitigation and emergency management is necessary.

Potential risks to any **place** of **cultural heritage value** should be assessed. Where appropriate, a risk mitigation plan, an emergency plan, and/or a protection plan should be prepared, and implemented as far as possible, with reference to a conservation plan.

Definitions

For the purposes of this charter:

Adaptation means the process(es) of modifying a **place** for a **compatible use** while retaining its **cultural heritage value**. **Adaptation** processes include alteration and addition.

Authenticity means the credibility or truthfulness of the surviving evidence and knowledge of the **cultural heritage value** of a **place**. Relevant evidence includes form and design, substance and **fabric**, technology and craftsmanship, location and surroundings, context and **setting, use** and function, traditions, spiritual essence, and sense of place, and includes **tangible** and **intangible values**. Assessment of **authenticity** is based on identification and analysis of relevant evidence and knowledge, and respect for its cultural context.

Compatible use means a **use** which is consistent with the **cultural heritage value** of a **place**, and which has little or no adverse impact on its **authenticity** and **integrity**.

Connected people means any groups, organisations, or individuals having a sense of association with or responsibility for a **place** of **cultural heritage value**.

Conservation means all the processes of understanding and caring for a **place** so as to safeguard its **cultural heritage value**. **Conservation** is based on respect for the existing **fabric**, associations, meanings, and **use** of the **place**. It requires a cautious approach of doing as much work as necessary but as little as possible, and retaining **authenticity** and **integrity**, to ensure that the **place** and its values are passed on to future generations.

Conservation plan means an objective report which documents the history, **fabric**, and **cultural heritage value** of a **place**, assesses its **cultural heritage significance**, describes the condition of the **place**, outlines **conservation** policies for managing the **place**, and makes recommendations for the **conservation** of the **place**.

Contents means moveable objects, collections, chattels, documents, works of art, and ephemera that are not fixed or fitted to a **place**, and which have been assessed as being integral to its **cultural heritage value**.

Cultural heritage significance means the **cultural heritage value** of a **place** relative to other similar or comparable **places**, recognising the particular cultural context of the **place**.

Cultural heritage value/s means possessing aesthetic, archaeological, architectural, commemorative, functional, historical, landscape, monumental, scientific, social, spiritual, symbolic, technological, traditional, or other **tangible** or **intangible values**, associated with human activity.

Cultural landscapes means an area possessing **cultural heritage value** arising from the relationships between people and the environment. **Cultural landscapes** may have been designed, such as gardens, or may have evolved from human settlement and land use over time, resulting in a diversity of distinctive landscapes in different areas. Associative **cultural landscapes**, such as sacred mountains, may lack **tangible** cultural elements but may have strong **intangible** cultural or spiritual associations.

Documentation means collecting, **recording**, keeping, and managing information about a **place** and its **cultural heritage value**, including information about its history, **fabric**, and meaning; information about decisions taken; and information about physical changes and **interventions** made to the **place**.

Fabric means all the physical material of a **place**, including subsurface material, **structures**, and interior and exterior surfaces including the patina of age; and including fixtures and fittings, and gardens and plantings.

Hapu means a section of a large tribe of the **tangata whenua**.

Intangible value means the abstract **cultural heritage value** of the meanings or associations of a **place**, including commemorative, historical, social, spiritual, symbolic, or traditional values.

Integrity means the wholeness or intactness of a **place**, including its meaning and sense of **place**, and all the **tangible** and **intangible** attributes and elements necessary to express its **cultural heritage value**.

Intervention means any activity that causes disturbance of or alteration to a **place** or its **fabric**. **Intervention** includes archaeological excavation, invasive investigation of built **structures**, and any **intervention** for **conservation** purposes.

Iwi means a tribe of the **tangata whenua**.

Kaitiakitanga means the duty of customary trusteeship, stewardship, guardianship, and protection of land, resources, or **taonga**.

Maintenance means regular and on-going protective care of a **place** to prevent deterioration and to retain its **cultural heritage value**.

Matauranga means traditional or cultural knowledge of the **tangata whenua**.

Non-intervention means to choose not to undertake any activity that causes disturbance of or alteration to a **place** or its **fabric**.

Place means any land having **cultural heritage value** in New Zealand, including areas; **cultural landscapes**; buildings, **structures**, and monuments; groups of buildings, **structures**, or monuments; gardens and plantings; archaeological sites and features; traditional sites; sacred **places**; townscapes and streetscapes; and settlements. **Place** may also include land covered by water, and any body of water. **Place** includes the **setting** of any such **place**.

Preservation means to maintain a **place** with as little change as possible.

Reassembly means to put existing but disarticulated parts of a **structure** back together.

Reconstruction means to build again as closely as possible to a documented earlier form, using new materials.

Recording means the process of capturing information and creating an archival record of the **fabric** and **setting** of a **place**, including its configuration, condition, **use**, and change over time.

Reinstatement means to put material components of a **place**, including the products of **reassembly**, back in position.

Repair means to make good decayed or damaged **fabric** using identical, closely similar, or otherwise appropriate material.

Restoration means to return a **place** to a known earlier form, by **reassembly** and **reinstatement**, and/or by removal of elements that detract from its **cultural heritage value**.

Setting means the area around and/or adjacent to a **place** of **cultural heritage value** that is integral to its function, meaning, and relationships. **Setting** includes the **structures**, outbuildings, features, gardens, curtilage, airspace, and accessways forming the spatial context of the **place** or used in association with the **place**. **Setting** also includes **cultural landscapes**, townscapes, and

streetscapes; perspectives, views, and viewshafts to and from a **place**; and relationships with other **places** which contribute to the **cultural heritage value** of the **place**. **Setting** may extend beyond the area defined by legal title, and may include a buffer zone necessary for the longterm protection of the **cultural heritage value** of the **place**.

Stabilisation means the arrest or slowing of the processes of decay.

Structure means any building, standing remains, equipment, device, or other facility made by people and which is fixed to the land.

Tangata whenua means generally the original indigenous inhabitants of the land; and means specifically the people exercising **kaitiakitanga** over particular land, resources, or **taonga**.

Tangible value means the physically observable **cultural heritage value** of a **place**, including archaeological, architectural, landscape, monumental, scientific, or technological values.

Taonga means anything highly prized for its cultural, economic, historical, spiritual, or traditional value, including land and natural and cultural resources.

Tino rangatiratanga means the exercise of full chieftainship, authority, and responsibility.

Use means the functions of a **place**, and the activities and practices that may occur at the **place**. The functions, activities, and practices may in themselves be of **cultural heritage value**.

Whanau means an extended family which is part of a **hapu** or **iwi**.

ISBN 978-0-473-17116-2 (PDF)

English language text first published 1993

Bilingual text first published 1995

Revised text Copyright © 2010 ICOMOS New Zealand (Inc.) / Te Mana O Nga Pouwhenua O Te Ao – The New Zealand National Committee of the International Council on Monuments and Sites.

No part of this publication may be reproduced, stored in a retrieval system, or transmitted by any other means without the prior permission of the copyright holder.

This revised text replaces the 1993 and 1995 versions and should be referenced as the *ICOMOS New Zealand Charter for the Conservation of Places of Cultural Heritage Value* (ICOMOS New Zealand Charter 2010).

This revision incorporates changes in conservation philosophy and best practice since 1993 and is the only version of the ICOMOS New Zealand Charter approved by ICOMOS New Zealand (Inc.) for use.

Copies of this charter may be obtained from

ICOMOS NZ (Inc.)

P O Box 90 851

Victoria Street West,

Auckland 1142, New

Zealand.

Appendix 2

SH8 Beaumont Bridge Phase 3 Strengthening

Drawings prepared by Opus International Consultants for the NZ Transport Agency, 2015

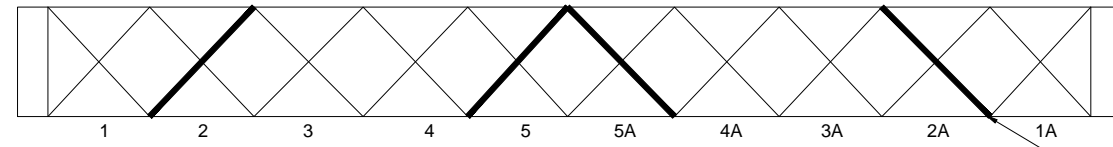
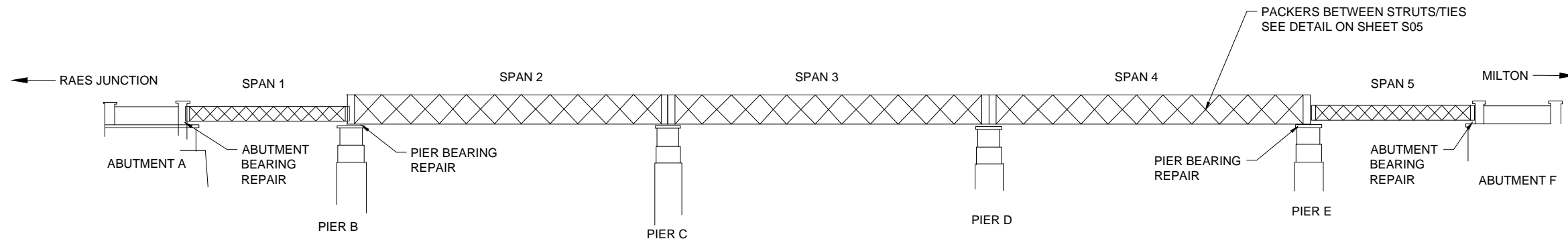

TRUSS BAY NUMBERING
SPANS 1&5

HIGHLIGHTED STRUTS TO BE STRENGTHENED (BOTH UPSTREAM & DOWNSTREAM SIDES OF BRIDGE)

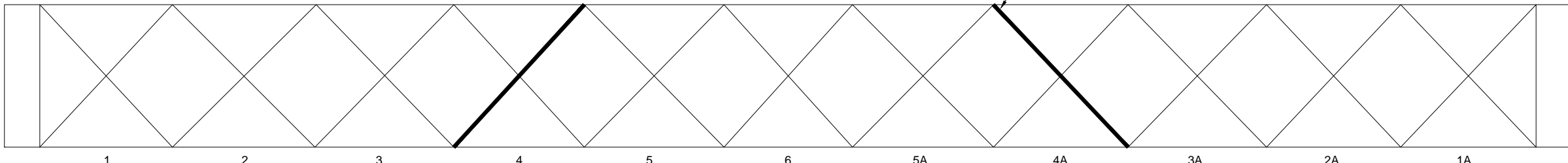

TRUSS BAY NUMBERING
SPANS 2,3&4

CONSTRUCTION

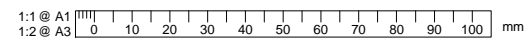

Revision	Amendment	Approved	Revision Date



Drawn	Designed	Approved	Revision Date
D.D.	R.O.	R.O.	14/9/15

Project No.	Scale
632074.01	N.T.S.

Project	
NZTA SH8 BEAUMONT BRIDGE PHASE 3 STRENGTHENING	
Sheet BRIDGE ELEVATION	
Drawing No.	Sheet No. Revision
6-32074.01 / 625GD	S01 R0

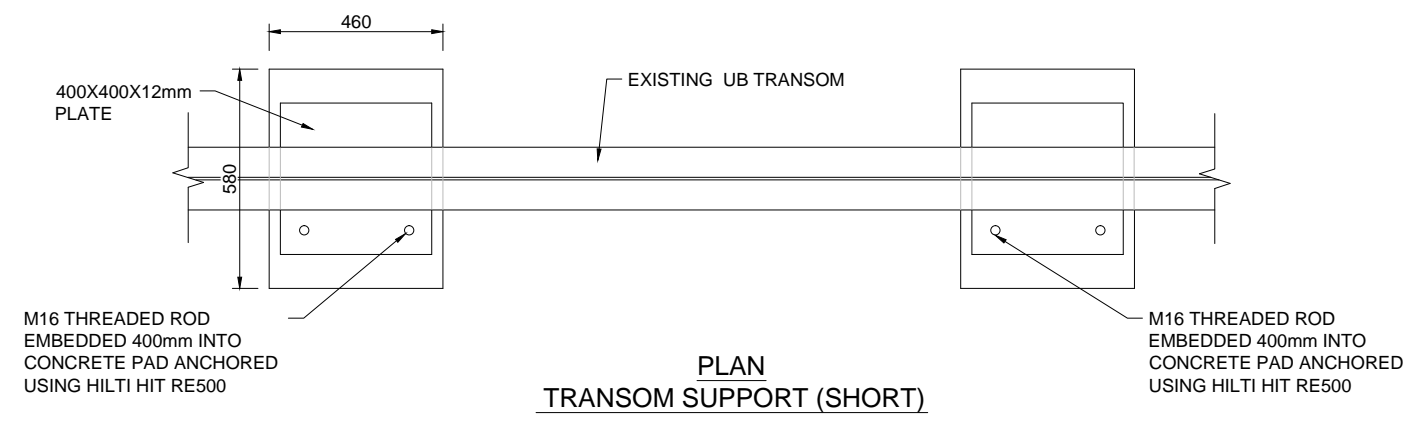
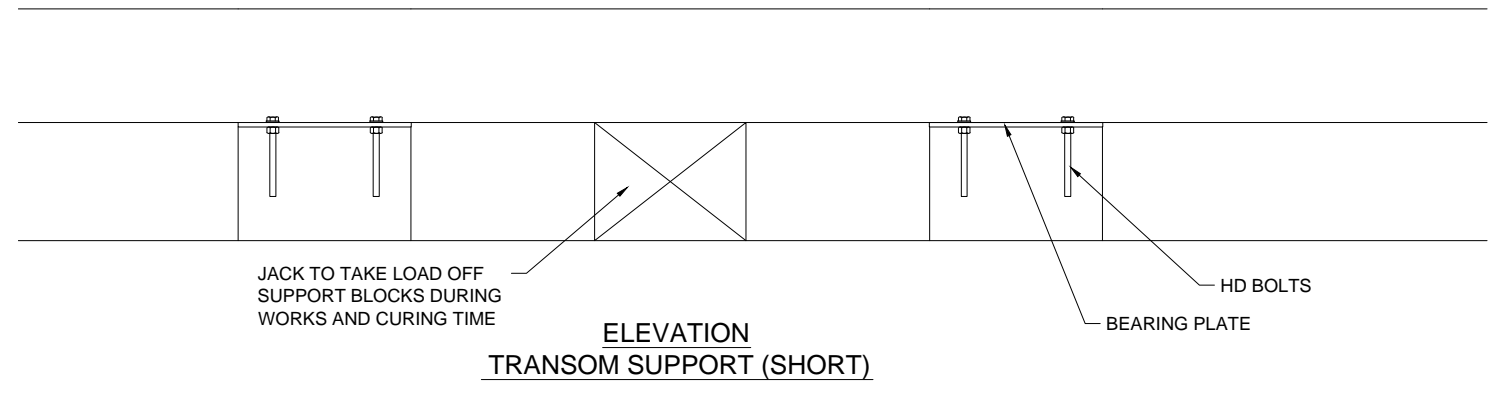
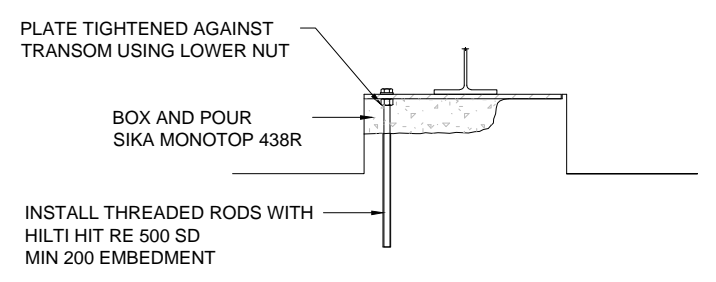
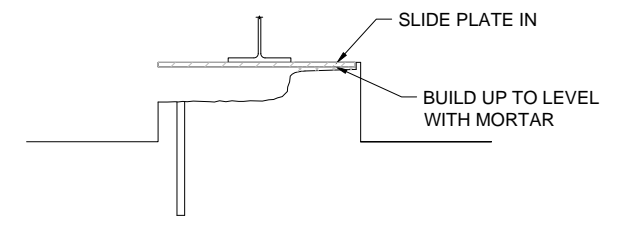
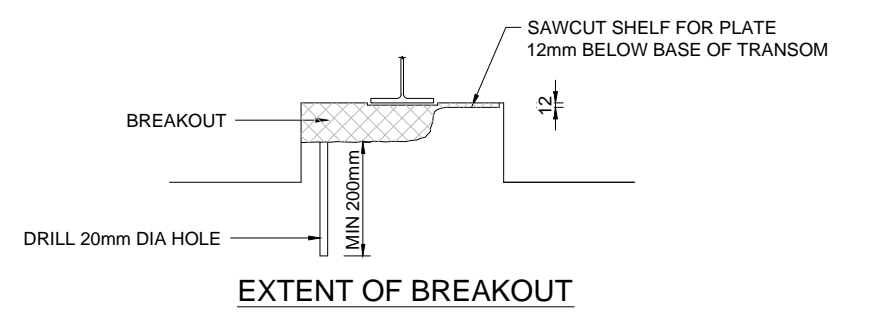
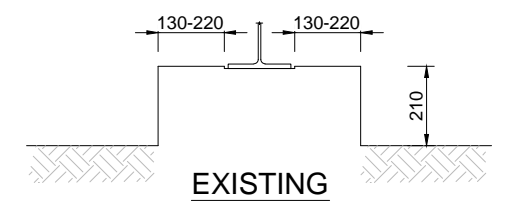

PHOTO SHORT SUPPORT



NOTE: TRANSOMS TO BE JACKED FOR THE DURATION OF THE WORKS

INSTALL STEEL PLATE

NOTES:
1. THE JACKS SHALL NOT BE RELEASED UNTIL THE REPAIR MORTAR HAS REACHED A MINIMUM COMPRESSIVE STRENGTH OF 20 MPa

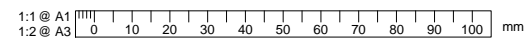

Revision	Amendment	Approved	Revision Date



Private Bag 1913
Dunedin 9016
New Zealand

Project		Sheet	
NZTA SH8 BEAUMONT BRIDGE PHASE 3 STRENGTHENING		TRANSOM BEARING REPAIRS SHORT BLOCKS	
Project No.	Scale	Drawing No.	Sheet No. Revision
632074.01	1:5 @ A1 1:2.5 @ A3	6-32074.01 / 625GD	S02 R0

CONSTRUCTION

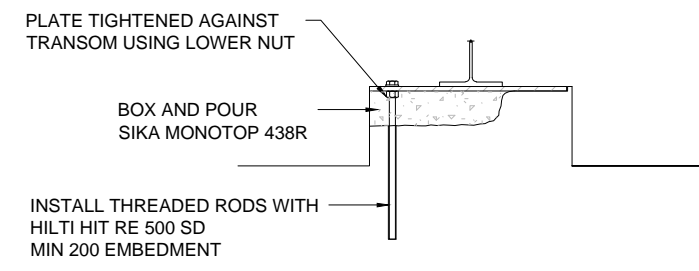
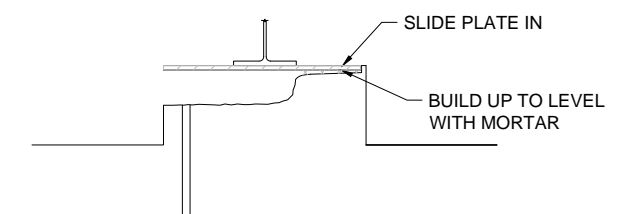
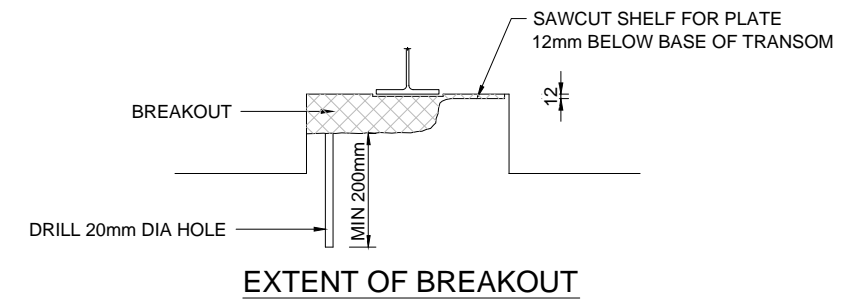
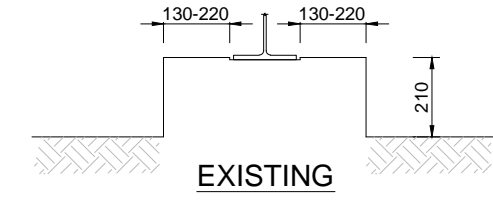
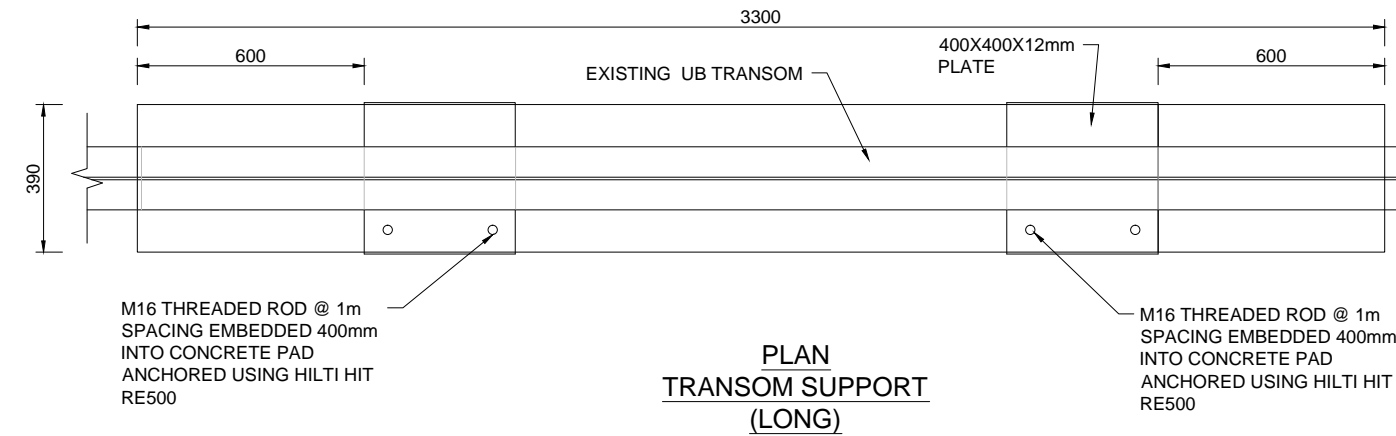
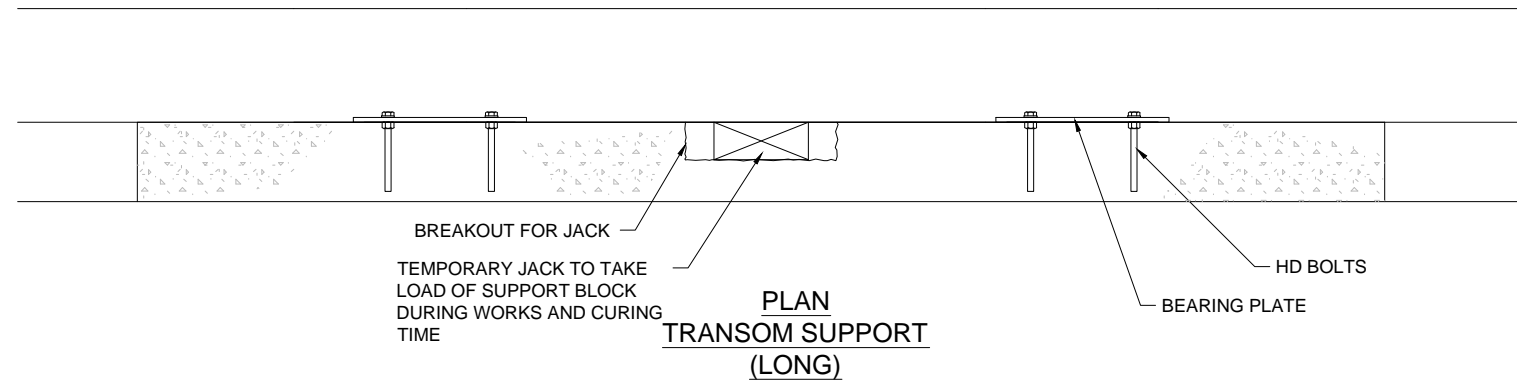

NOTE: TRANSOMS TO BE JACKED FOR THE DURATION OF THE WORKS

INSTALL STEEL PLATE

PHOTO LONG SUPPORT

NOTES:
1. THE JACKS SHALL NOT BE RELEASED UNTIL THE REPAIR MORTAR HAS REACHED A MINIMUM COMPRESSIVE STRENGTH OF 20 MPa

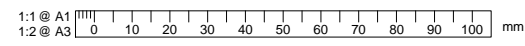

\\sawd1\proweb\STRUCTURAL\6CNT42.00 - Bridge Management\TNZ 00-178\5. Bridges\Bridges\SH8\401-6.24 Beaumont\28. HPMV strengthening\Photos 24-7-2015\F1280284.JPG

CONSTRUCTION

Revision	Amendment	Approved	Revision Date

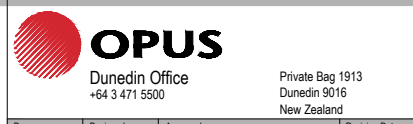

Project		NZTA SH8 BEAUMONT BRIDGE PHASE 3 STRENGTHENING	
Sheet		TRANSOM BEARING REPAIRS LONG BLOCKS	
Drawn	Designed	Approved	Revision Date
D.D.	R.O.	R.O.	14/9/15
Project No.		Scale	Drawing No.
632074.01		1:5@ A1 1:2.5 @A3	6-32074.01 / 625GD
Sheet No.	Revision		
S03	R0		

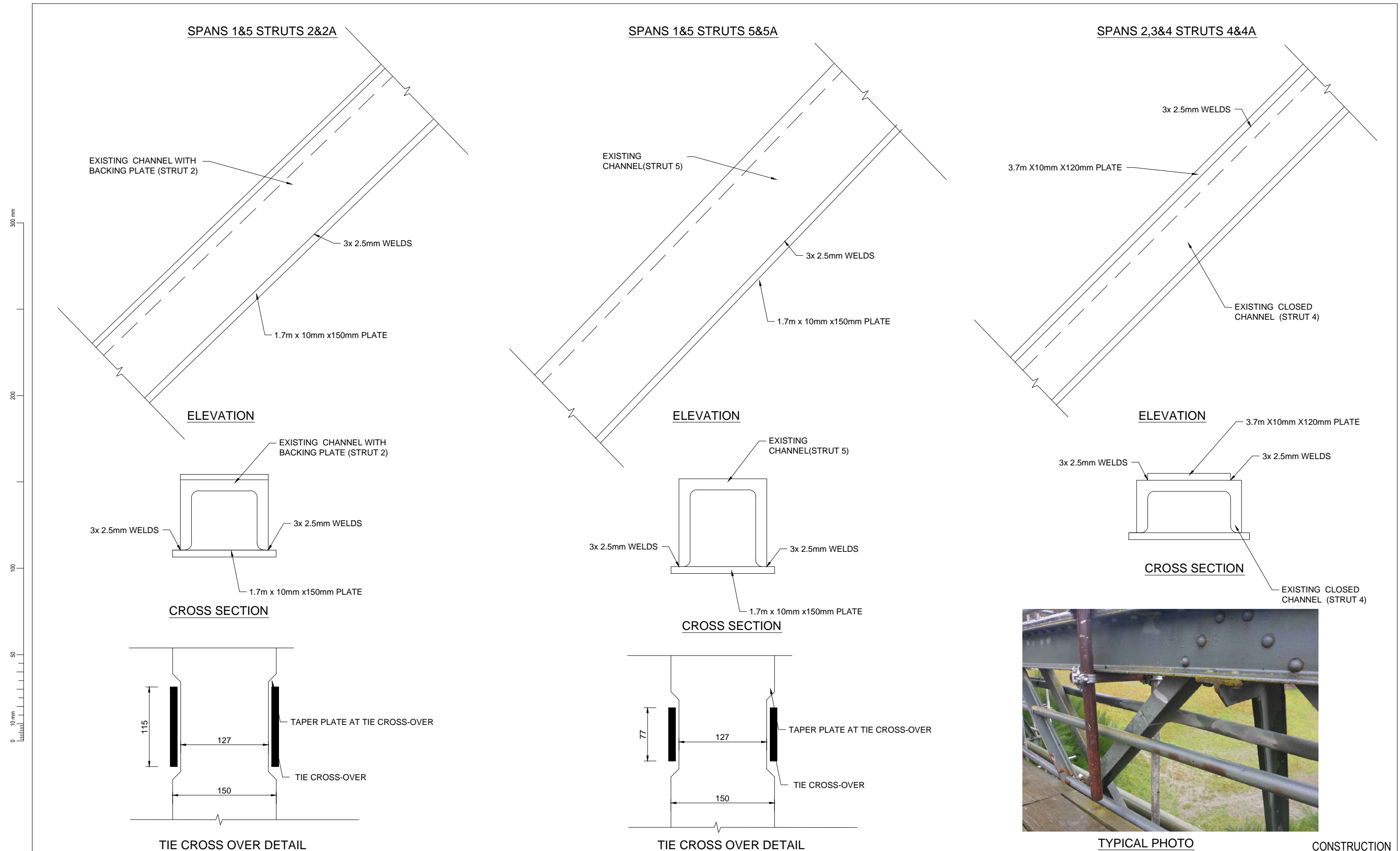

TYPICAL PHOTO

CONSTRUCTION

Revision	Amendment	Approved	Revision Date



Private Bag 1913
Dunedin 9016
New Zealand

Project			
NZTA SH8 BEAUMONT BRIDGE PHASE 3 STRENGTHENING			
Sheet			
STRUT STRENGTHENING DETAILS			
Drawn	Designed	Approved	Revision Date
D.D.	R.O.	R.O.	14/9/15
Project No.		Scale	Drawing No.
632074.01		1:2.5@ A1 1:5 @A3	6-32074.01 / 625GD
Sheet No.	Revision		
S04	R0		

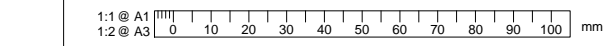

SPAN 1, UPSTREAM BAY 1 END BRACE - WELD CRACK



GRIND OUT DEFECTIVE WELD AND RE-WELD OUTSIDE OF MEMBER. LENGTH 400mm. (SEE BELOW IMAGE)

OUTSIDE OF MEMBER



GRIND OUT AND WELD CRACK INSIDE OF MEMBER. LENGTH 400mm.

INSIDE OF MEMBER

SPAN 2, UPSTREAM BAY 6 TIE- WELD CRACK



GRIND OUT AND WELD CRACK

GAS CUT TIES - PLUG WELD



CRACK AT TOP OF WELD

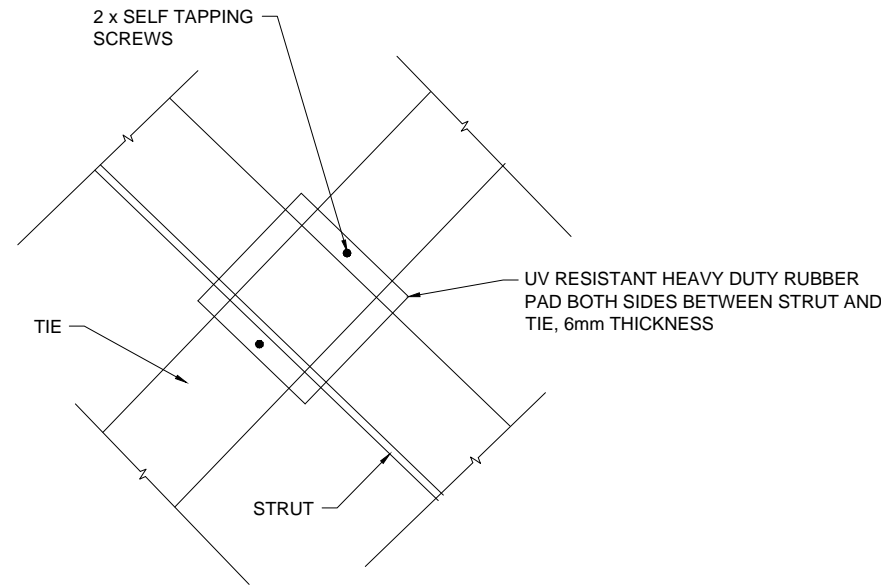

RUBBER PACKING DETAIL
1:5



PREP AND PLUG WELD HOLES(ONLY HOLES THAT HAVE GAS CUTTING THAT EXTENDS BEYOND THE HOLE APPROX 10) 10mm DIAMETER

CONSTRUCTION

1:1 @ A1
1:2 @ A3
0 10 20 30 40 50 60 70 80 90 100 mm

Revision	Amendment	Approved	Revision Date



Private Bag 1913
Dunedin 9016
New Zealand

Drawn	Designed	Approved	Revision Date
D.D.	R.O.	R.O.	14/9/15

Project No.	Scale	Drawing No.
632074.01	1:2.5@ A1 1:5 @A3	6-32074.01 / 625GD

Project	
NZTA SH8 BEAUMONT BRIDGE PHASE 3 STRENGTHENING	
Sheet	
WELD REPAIRS	
Sheet No.	Revision
S05	R0

SPAN 3, UPSTREAM BAY3a - REPLACE RIVET WITH TAPPED BOLT

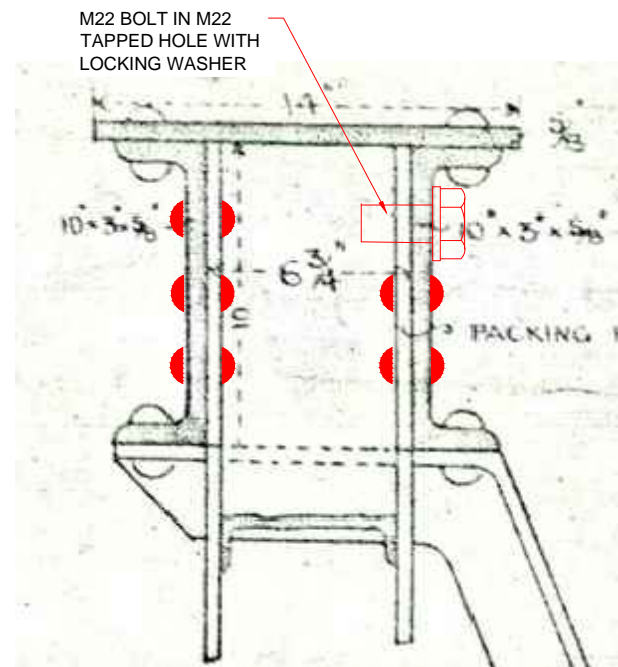

DRILL OUT THE EXISTING RIVET. TAP OUT THE HOLE TO SUIT A M22 BOLT. INSTALL THE BOLT FROM THE OUTSIDE FACE WITH A LOCKING WASHER. DO NOT OVER-TIGHTEN (WE DO NOT WANT TO STRIP THE THREAD ON THE WROUGHT IRON.)

300 mm
200
100
50
10 mm
0

CONSTRUCTION

1:1 @ A1
1:2 @ A3
0 10 20 30 40 50 60 70 80 90 100 mm

Revision	Amendment	Approved	Revision Date



Drawn	Designed	Approved	Revision Date
D.D.	R.O.	R.O.	14/9/15
Project No.		Scale	
632074.01		1:2.5@ A1 1:5 @A3	

Project	
NZTA SH8 BEAUMONT BRIDGE PHASE 3 STRENGTHENING	
Sheet	
BOLTING REPAIRS	
Drawing No.	Sheet No. Revision
6-32074.01 / 625GD	S06 R0

SPAN 4, UPSTREAM, BAY 3a - MISSING RIVET REPLACE WITH BOLT



A RIVET IS MISSING ON THE TOP OF THE TOP CHORD, A M20 BOLT SHALL BE INSTALLED TO REPLACE THE MISSING RIVET. TOTAL PLATE THICKNESS IS 51mm



ABUTMENT A EXPANSION ALLOWANCE
(UPSTREAM AND DOWNSTREAM HOLD DOWN BOLTS)
(PROVISIONAL)



REMOVE NUT AND WASHER FROM HOLD DOWN BOLTS AT ABUTMENT A AND CUT A LARGER SLOTTED HOLE IN THE BASE PLATE TO ALLOW THE TRUSS TO SLIDE BACK FURTHER TOWARDS THE ABUTMENT BACK WALL, EXTEND HOLE BY APPROX 50mm, EXTENT TO BE CONFIRMED ON SITE BY ENGINEER. ONCE NUT AND WASHER HAVE BEEN REMOVED. REINSTATE WASHER AND NUT.

300 mm
200
100
50
10 mm
0

1:1 @ A1
1:2 @ A3
0 10 20 30 40 50 60 70 80 90 100 mm

CONSTRUCTION

Revision	Amendment	Approved	Revision Date



OPUS
Dunedin Office
+64 3 471 5500

Private Bag 1913
Dunedin 9016
New Zealand

Drawn	Designed	Approved	Revision Date
D.D.	R.O.	R.O.	14/9/15

Project No.	Scale
632074.01	1:2.5@ A1 1:5 @A3

Project	
NZTA SH8 BEAUMONT BRIDGE PHASE 3 STRENGTHENING	
Sheet	
BOLTING REPAIRS	
Drawing No.	Sheet No. / Revision
6-32074.01 / 625GD	S07 / R0



Opus International Consultants Ltd

Opus House, 197 Rattray Street
Private Bag 1913, Dunedin 9054
New Zealand

t: +64 3 471 5500
f: +64 3 474 8995
w: www.opus.co.nz