

Appendix P

Design Philosophy Bridges

Helmess Consulting Group



REPORT

STRUCTURAL AND CIVIL ENGINEERS

PEKA PEKA TO NORTH OTAKI
EXPRESSWAY

CONTRACT NO. 440PN:

DESIGN PHILOSOPHY BRIDGES

PREPARED FOR

NZ TRANSPORT AGENCY

12 SEPTEMBER 2011

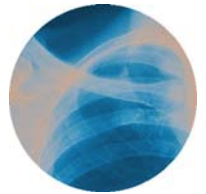



REPORT

Peka Peka to North Otaki Expressway
Project Number 440PN
Design Philosophy Bridges

Prepared For:
NZ Transport Agency

Date: 12 September 2011
HCG Project No: 104866
Revision No: Draft

HolmesConsultingGroup



Prepared By:

Reviewed By:

Phil Gaby
PROJECT DIRECTOR

Rob Presland
PROJECT DIRECTOR

Holmes Consulting Group Limited
Wellington Office



CONTENTS

	Page
CONTENTS	I
EXECUTIVE SUMMARY	II
1 BACKGROUND.....	1
1.1 Introduction	1
1.2 Project Bridges	1
1.3 Bridge Forms	1
2 BRIDGE SELECTION CRITERIA.....	3
2.1 Introduction	3
2.2 Best Value.....	3
2.3 Seismicity.....	4
2.3.1 Seismic Hazard.....	4
2.3.2 Route Security.....	5
2.4 Whole of Life Performance	5
2.5 Community Expectations	5
2.6 Aesthetics.....	6
2.7 Functional Requirements	6
2.8 Design Standards	8
2.9 Geotechnical Conditions.....	8
3 OPTIONS CONSIDERED.....	9
3.1 Waitohu Stream & Otaki River (Bridges 1 & 5)	9
3.2 Otaki North, Rahui, South Otaki and Te Horo (bridges 3, 4, 7 & 8).....	10
3.3 Bridges 2 & 6.....	10
3.4 Bridge 9 – Mary Crest.....	10
3.5 Bridge 10 Pedestrian/Cycle Extension to the Existing Otaki River Bridge	11
4 RECOMMENDATIONS.....	12
4.1 Bridge Form.....	12
4.1.1 Superstructures.....	12
4.1.2 Substructures.....	12
4.2 Evaluation and Selection	12
APPENDIX 1 – BRIDGE DRAWINGS	14



The ten bridges in this project are listed in the table below:

Bridge No.	Bridge Name	Description	Length (m)	Width (m)
1	Waitohu Stream	Expressway over Waitohu Stream	82	23
2	Otaki North rail	Local road over NIMT rail	18.4	16.9
3	Otaki North	Local Road over expressway	36.2	16.9
4	Rahui Road	Rahui Road over expressway	115	13.9
5	Otaki River Bridge	Expressway over Otaki River	332	23
6	South Otaki rail	Local road over NIMT rail	17.1	15.4
7	South Otaki	Local road over expressway	58	15.4
8	Te Horo	Local road over expressway	102	11.9
9	Mary's Crest	Expressway over NIMT & local road	152	19.3
10	Pedestrian/Cycle extension to existing Otaki River Bridge	Pedestrian/Cycle extension over river	190	3

Table 1: Project Bridges

Recommended bridge forms for these structures are as follows.

Bridge No.	Bridge Name	Bridge Form
1	Waitohu Stream	Architecturally designed 3-span super "T",
2	Otaki North rail	Single span hollow core
3	Otaki North	2-span concrete box
4	Rahui Road	5-span concrete box
5	Otaki River Bridge	Architecturally designed 11-span Super "T"
6	South Otaki rail	Single span hollow core
7	South Otaki	2-span concrete box
8	Te Horo	5-span concrete box
9	Mary Crest	Precast beam & slab bridge
10	Otaki River Bridge Extension	Super "T" on circular columns

Table 2: Project Bridge Forms

Concept drawings of these structures are contained in Appendix 1.

All bridges are founded on bored reinforced concrete piles in line with the recommendations of the Geotechnical Report.

Mechanically stabilised earth (MSE) abutment walls and wingwalls are proposed in the preliminary designs. These types of walls are known to perform very well in earthquakes and can be very attractive if care is taken with their detailing.

Bridge structures 1 & 5 (Waitohu Stream and Otaki River) are super 'T' bridges with architecturally designed substructures and barriers. The form is economic and with architectural enhancements has reasonable aesthetics. The form is a best value compromise between stakeholder desires for attractive bridges (Otaki River Bridge in particular) and cost.

Bridges 2 & 6 are relatively small structures that are hidden from view. Economical and slender hollow core bridges are appropriate solutions for these structures. Robust and highly redundant fully integral construction is proposed for these bridges delivering good seismic performance due to framing between the substructure and superstructure and low maintenance costs as a result of the elimination of bearings and joints.

Bridges 3, 4, 7 & 8 are a family of highly visible (from the expressway in particular) local road over expressway structures. Sleek concrete box bridges are proposed for these bridges in line with stakeholder expectations at Rahui in particular for attractive bridge. The bridges are more expensive than typically less attractive super 'T' bridges. Given that the four bridges account for only 30% of the total structures estimate, the resulting increase in total bridge budget is relatively modest when compared to the cheapest conforming solution approach. These bridges are fully integral with the same advantages described for Bridges 2 & 6.

Bridge 9, Mary Crest Bridge, is a very economic beam and slab bridge solution that is also elegant, turning what could otherwise have been a chunky and dingy rail crossing into an interesting and airy rail and local road overbridge. The fully framed portal bridge has no bearings and joints meaning little or no maintenance for much of its life. It is also a highly redundant and robust form that is likely to perform well under earthquake loading.

Bridge 10 is a 3m wide cycleway/pedestrian extension A to the existing SH1 Otaki River Bridge. The form proposed is a simple and economic super 'T' beam and slab deck supported on circular columns.



1.1 INTRODUCTION

This report describes the bridges of the Peka Peka to Otaki (PP20) scheme. An outline on and how key factors influencing the selection of bridge form is followed by recommendations on what the final form of the bridges on this project might look like. General arrangement drawings of each of the bridges are contained in Appendix 1.

1.2 PROJECT BRIDGES

The ten bridges in this project are listed in the table below:

Bridge No.	Bridge Name	Description	Length (m)	Width (m)
1	Waitohu Stream	Expressway over Waitohu Stream	82	23
2	Otaki North rail	Local road over NIMT rail	18.4	16.9
3	Otaki North	Local Road over expressway	36.2	16.9
4	Rahui Road	Rahui Road over expressway	115	13.9
5	Otaki River Bridge	Expressway over Otaki River	332	23
6	South Otaki rail	Local road over NIMT rail	17.1	15.4
7	South Otaki	Local road over expressway	58	15.4
8	Te Horo	Local road over expressway	102	11.9
9	Mary's Crest	Expressway over NIMT & local road	152	19.3
10	Pedestrian/Cycle extension to existing Otaki River Bridge	Pedestrian/Cycle extension over river	190	3

Table 3: Project Bridges

The length, width and span arrangements of the bridges are generally governed by the roading geometry, obstacles crossed including rivers, local roads, the expressway itself, the NIMT railway and provisions for pedestrian, equestrian and cycle use.

Mechanically stabilised earth (MSE) or reinforced soil embankment (RSE) abutment walls and wingwalls are proposed in the preliminary designs. These types of walls are known to perform very well in earthquakes and can be very attractive if care is taken with their detailing. Wherever possible, these walls are sloped.

1.3 BRIDGE FORMS

A number of bridge forms were considered for each of these structures. The forms are listed below in order of increasing cost. Generally the higher cost the better aesthetics.

- Lowest cost super 'T' and hollow core options (considered for all 10 bridges). No architectural enhancements are provided with this approach.

- Super ‘T’ bridges with architectural treatments to piers and barriers (river crossings and Otaki North, Rahui, Otaki South and Te Horo)
- More expensive and aesthetically superior concrete box bridges (river bridges and Otaki North, Rahui, Otaki South and Te Horo)
- Gateway and or iconic style bridge including arches, cable stayed and other ‘gateway’ ‘iconic’ forms (Otaki River and Waitohu Stream Bridges)

Early on, it was identified that gateway or iconic structural forms that were prominent in the landscape, were not desirable from a landscape and urban design viewpoint (see Landscape and Urban Design Framework). Therefore, gateway or iconic structural forms were eliminated from the options list.

Gateway treatments are however considered appropriate in the landscape before, after and between interchanges rather than at structure locations. Recommended treatments are discussed in detail in the Urban and Landscape Design Framework.

Bridge solutions with good architecture were considered a ‘must have’ particularly at the more visible local road over expressway crossings and this is reflected in concrete box structure types being proposed for Otaki North (No. 3), Rahui (No. 4), Otaki South (No. 7) and Te Horo (No. 8) crossings.

Super ‘T’ bridges with treatments to piers and barriers are proposed for the river crossings as the costs with adopting the more elegant concrete box bridge form for these relatively large structures is probably not justified.

The local road over rail bridges are small and hidden so lowest cost hollowcore bridges are proposed for these.

The Mary Crest structure, described in detail in later sections, is an economic and elegant beam and slab bridge.

Wherever possible, sloped abutment walls consisting of geogrid reinforcement and concrete facing panels have been adopted, as these are considered visually superior to vertical abutment walls.



2.1 INTRODUCTION

Selection of form and development of bridge solutions was influenced by each of the following:

- The requirement to provide value for money (best value)
- Seismicity
- Whole of life performance
- Community expectations
- Aesthetics
- Functional requirements
- Design Standards
- Geotechnical conditions

An outline of how each of these influenced the final outcomes follows.

2.2 BEST VALUE

Best value aims to deliver the best outcome taking into account all relevant criteria including initial cost, whole of life performance, community expectations and aesthetics. Recommended best value solutions are not always the cheapest options as desired or must-have outcomes such as good aesthetics generally, but not always, come at an extra cost.

Perhaps the standout 'best value' example in this scheme is the recommended structural form for the Mary Crest Bridge. A very economic solution that is also an elegant bridge form is proposed, turning what could of otherwise have been a chunky and dingy rail crossing into an interesting and airy rail and local road overbridge. The fully framed portal bridge has no bearings and joints meaning little or no maintenance for much of its life. It is also a highly redundant and robust form that is likely to perform well under earthquake loading.

Sleek concrete box bridges are proposed for the local road over expressway underbridges (bridges 3, 4, 7 & 8). The bridges are more expensive than generally less attractive Super "I" bridges. Given that the four bridges account for only 30% of the total structures estimate, the resulting increase in total bridge budget is relatively modest when compared to the cheapest conforming solution approach. Again, this is a 'best value' outcome with a good balance between aesthetics and cost delivered.

Use of more conventional Super ‘T’ structural forms for the river crossings, but with architectural treatments provided to the piers and barriers, is considered the best value for these structures. The large scale of these structures and the limited visibility of these bridges from the expressway or local arterial roads does not warrant the adoption of the more expensive concrete box form.

Economical hollowcore bridges provide the best value solution for the local road over rail bridges (bridges 2 & 6). These bridges are not particularly visible and therefore do not warrant significant investment on aesthetic treatments. Best value here is to use the cheapest bridge form for these bridges.

2.3 SEISMICITY

2.3.1 Seismic Hazard

Given the route’s close proximity to active faults, a site specific seismic hazard study is required and preferably for next phase of the project. This is in accordance with the requirements of the TNZBM, draft amendment section titled ‘Earthquake Resistance Design’, June 2005. This document is yet to be formally adopted by NZTA but has been taken into account and used as the basis to the preliminary design of PP20 structures.

A major contributor to the seismic hazard on the route is the Ohariu Fault. In addition to the Ohariu Fault (recurrence between 1800 – 3450 yrs depending on location), other active earthquake sources in the region pose a significant hazard including the Wellington Fault (840 yr recurrence), Wairarapa Fault (1200 yr recurrence), Moonshine Fault (13000 yr), Shepherds Gully Fault (7000 yr recurrence) and the Hikurangi Subduction zone (420 yr recurrence). Contributions to the seismic hazard from these faults will be included in the derivation of the site specific hazard spectra.

In the absence of a site specific hazard study at this stage of the project, the seismic hazard has been assumed to be in line with the recommendations of NZS1170 Part 5.

Ongoing research and understanding of local seismology and seismic hazards has been undertaken since the publication of NZS1170. This ongoing work can be captured in site specific seismic studies and could result in an increase in seismic demand for structures on this project. An increase in seismic demand is likely to result in higher construction costs.

Seismic event return periods and performance criteria for the structures on this project are in accordance with Tables 2.1 and 5.1 of the June 2005 draft amendment. Bridge structures and retaining structures associated with bridges will be designed for a seismic return period of 2500 years at ULS. Serviceability limit state SLS 1 & SLS 2 return periods are generally 100 years and 500 years respectively for all of the project’s bridges and retaining walls.

Retaining walls not associated with bridges will, in general, be designed to withstand a seismic event with a return period of 1000 years. A displacement based design approach is considered appropriate for the design of all retaining walls (both MSE and RSE walls). Design displacements of around 150mm are considered appropriate in most instances.

In general, site specific spectra with 5% damping in accordance with NZS1170 (or site specific seismic study) will be used for the seismic design. Should mechanically damped devices (such as lead rubber bearings) be incorporated into bridge structures, damping

values appropriate to chosen systems will be calculated and applied as part of the analysis.

2.3.2 Route Security

An objective of the project is to provide a strategic link for Wellington with improved regional network security. The most significant threat to route security is large earthquakes. This risk has influenced the selection of structural configurations in a number of ways. In particular, robust structural forms with high levels of redundancy are proposed as described in the following paragraphs.

Bridges 2 – 4 and 6 – 9 are of fully integral construction, as these bridges have appropriate configurations (short to medium length structures with flexible substructures) to permit this form of construction. These structures have cast in-situ concrete connections between the superstructure components (deck and beams), and substructure (piers and abutments), which provide very good resistance to earthquake forces and potential ground movements. The bridges are founded on bored piles which are robust and perform well in earthquakes.

The Otaki River & Waitohu Stream Bridges (bridges 1, 5 & 10) are founded on bored piles supporting reinforced concrete piers and abutments. This commonly used and proven structural form performs well in earthquakes with seismic resistance being provided by cantilever piers and pile/ pile cap bents. The bridges are either too long and or too stiff to be made fully integral and as such the superstructures will be supported on bearings at each pier.

2.4 WHOLE OF LIFE PERFORMANCE

Bridge maintenance and repair costs are considerations in whole of life costing. Generally, the most maintenance intensive items in a bridge are bearings and joints and in the case of steel bridges, repainting costs. Low maintenance bridge forms have therefore been chosen for the bridges.

Bridges 2– 4 and 6 – 9 are particularly low maintenance structures with no bearings, expansion joints or coating systems that may require attention during the life of the structure. Whole of life performance is expected to be excellent for these structures.

With careful detailing of the Waitohu Stream and Otaki River Bridges, ensuring that good access for inspection and maintenance as well as provision for bearing and expansion joint repair and replacement is provided, a reasonable ‘whole of life’ performance of these bridges is also anticipated.

2.5 COMMUNITY EXPECTATIONS

Throughout the development of bridge concepts, the views of stakeholders have been sought and considered in light of the overall project objectives. This process has generally delivered outcomes that are visually acceptable, have stakeholder buy in and are still economic.

The Rahui Road Bridge is a prime example of successful stakeholder involvement. Many options were considered for the bridge with the final solution, embraced by the local community, being an affordable, sleek, soft and elegant concrete box bridge founded on shaped piers.

The bridge form proposed at Rahui Road has subsequently been adopted for the other under bridges (bridges 3, 7 and 8) for consistency of bridge structural form and appearance on this project. This proposed structural form could also be used for the Otaki River and Waitohu Stream Bridges should funds permit.

2.6 AESTHETICS

The intrinsic but unquantifiable value of good aesthetics has been rediscovered. Cheap chunky bridges are generally no longer acceptable. Of course good looking bridges also need to be (and can be) affordable.

The solutions proposed for the scheme demonstrate a good balance between looks and cost. Case in point are the four under bridges (bridges 3, 4, 7 and 8) which all have a similar concrete box forms. Economy is realised through re-use of formwork and falsework across several structures. At the same time subtle elegant bridges with a contemporary form that is unlikely to date, are provided.

The Otaki River and Waitohu Stream Bridges are fitted with architecturally designed piers and abutments and will have greatly improved aesthetics for a relatively small additional cost.

Considerable care has been taken in the development of the concept for Mary Crest. A very economic solution that is also an elegant bridge form is proposed turning what could otherwise have been a chunky and dingy rail crossing into an interesting and airy rail and local road overbridge.

Bridge aesthetics are also covered in detail in the Urban Design and Landscape Design Framework

2.7 FUNCTIONAL REQUIREMENTS

Bridge widths are determined by the roadway geometric design. Clearances under the bridges follow the recommendations of Appendix A of the TNZBM. Expressway overbridges typically carry four lanes of traffic depending on their location along the route, in addition to shoulders, verges and central reserves.

Underbridges carrying local roads over the expressway support footways in addition to the road.

Bridge carriageway configurations are as follows

Bridge No.	Name	Description	Carriageway configuration
1	Waitohu Stream	Expressway over Waitohu Stream	Southbound Near side shoulder 2.5m 2 no. 3.5m lanes Offside shoulder 1m
			Central reserve 6m
			Northbound Near side shoulder 6.0m 1 no. 3.5m lanes Offside shoulder 1m
2	Otaki North rail	Local road over NIMT rail	2 no 4.2m near side lanes 3.5m centre turning lane 1.5m footway north side 2.5m footway south side
3	Otaki North	Local Road over expressway	2 no 4.2m near side lanes 3.5m centre turning lane 1.5m footway north side 2.5m footway south side
4	Rahui Road	Rahui Road over expressway, NIMT and local road	2 no 4.2m near side lanes 2.5m footway north side 2.0m footway south side
5	Otaki River Bridge	Expressway over Otaki River	Near side shoulders 2.5m 2 no. 3.5m lanes each way Offside shoulder 1m Central reserve 6m
6	South Otaki rail	Local road over NIMT rail	2 no 4.2m near side lanes 3.5m centre turning lane 2.5m footway north side
7	South Otaki	Local road over expressway	2 no 4.2m near side lanes 3.5m centre turning lane 2.5m footway north side
8	Te Horo	Local road over expressway & NIMT	2 no 4.2m near side lanes 2.5m footway south side
9	Mary's Crest	Expressway over NIMT & local road	Near side shoulders 2.5m 2 no. 3.5m lanes each way Offside shoulder 1m Central reserve 6m
10	Old Otaki Bridge	Pedestrian/Cycle extension over river	3m combined/ cycle way

Table 4: Bridge Configurations

2.8 DESIGN STANDARDS

Preliminary designs have been developed in conformance with the Transit New Zealand Bridge Manual (TNZBM) (Transit, 2003) including amendments up to July 2005. Consideration has also been given to proposed draft amendments to the Bridge Manual particularly as related to seismic design provisions. HN-HO-72 live loading has been assumed in preliminary designs. Other relevant standards include:

- NZS 1170.5 – Seismic Loading Standard
- NZS 3101 – Concrete Structures Standard
- NZS 3404 – Steel Structures Standard
- AS 5100 – Bridge Design Code (Australia)

Consideration has also been given to the effects of the recently introduced high productivity motor vehicle (HPMV) weight allowances on the bridge designs. These allowances permit trucks of around 60 tonnes (current limit 44 tonnes) with heavier axles loads to use parts of the road network. Work carried out to-date however, indicates that the load effects of HPMV vehicles are similar to that of HN loading applied in accordance with the Bridge Manual. Little if any impact on the design of the Project's structures is therefore anticipated with the introduction of these vehicles.

2.9 GEOTECHNICAL CONDITIONS

Geotechnical conditions are reasonably well understood throughout the route. These are described in detail in the Geotechnical Report.

Ground conditions in general suit bored piled foundations founded in dense gravels or socketed into the bedrock.

Shallow undercutting of soils and replacement of these with compacted selected material is likely to be required under abutment retaining wall foundations.



3.1 WAITOHU STREAM & OTAKI RIVER (BRIDGES 1 & 5)

Options considered for these bridges included:

- Option 1 - Lowest cost option – Super “T” beams on circular columns and reinforce concrete hammerhead caps.
- Option 2 - Intermediate option – Super “T” beams on architecturally designed piers with elegant precast barriers
- Option 3 - A Best visual outcome option – Architecturally designed concrete box bridge deck and substructure
- Option 4 - Iconic/ Gateway bridges - Long-span arch bridge across the Otaki River (substantially more expensive than any of the other 3 solutions)

Cross-sections at the piers of Options 1 -3 are shown in Figure 1, as follows.

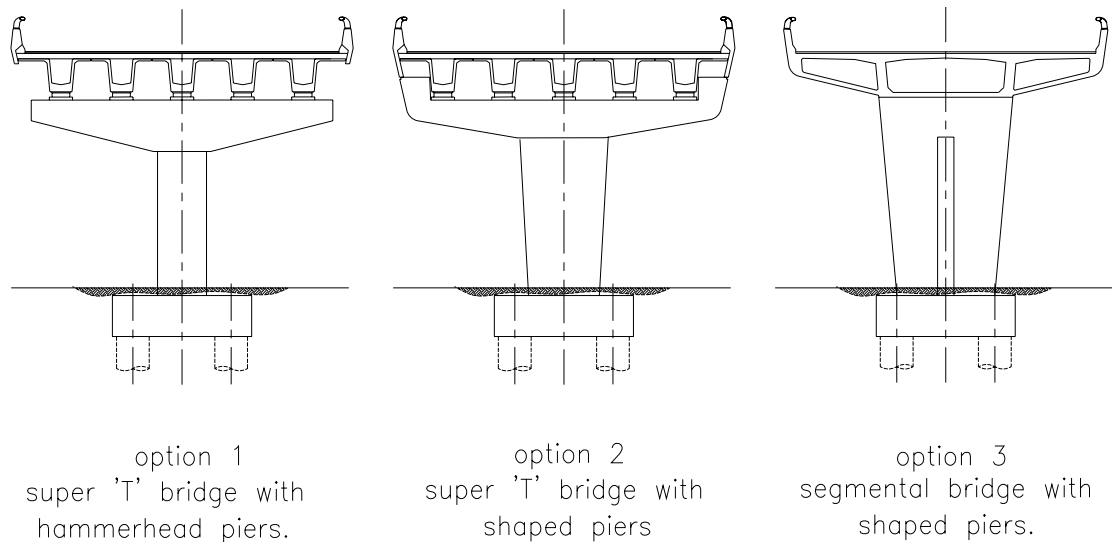

Figure 1: Bridge Configurations for river crossings

As noted earlier, Option 4 was eliminated early on in the process on the premise that gateway or iconic structural bridge forms did not fit with this section of the RoNS.

Option 1 is probably not in line with the expectations of the local community who are strongly in favour of a good visual outcome and is therefore ruled out.

Option 3 provides an aesthetically superior bridge form but at a higher cost.

Given architectural/urban design inputs and available view shafts to the new river crossings Option 2 is considered to provide the best compromise between cost and aesthetics and is therefore the recommended bridge form for the river crossings. The proposal is aesthetically superior to Option 1 and aims to adopt style articulations from the other local road bridges (e.g. Rahui Road Bridge) through adopting an extended barrier profile. Appearance of these bridges from the viewpoint of recreational river users will be a key focus given the limited visibility of these bridges from the expressway or local arterial roads.

Full costings for the options are contained in SAR.

3.2 OTAKI NORTH, RAHUI, SOUTH OTAKI AND TE HORO (BRIDGES 3, 4, 7 & 8)

Options 1 – 3 bridge forms shown in Figure 1 above for the Otaki River and Waitohu Stream Bridges are also appropriate for these four bridges.

Given the visual prominence and setting of these structures, the architectural/urban design treatment is considered important. At Rahui Road and at the Otaki North structure the bridges will be highly visible from surrounding reserve/open space areas. As such, it is felt that Option 1 or 2 are unlikely to meet the expectations of stakeholders and the stated desire of NZTA to provide a structure of lasting visual value. It is also important that all four underbridges on this project read similarly so a consistent structural form is recommended for these structures.

Option 3 is the proposed configuration for these four bridges delivering sleek, soft and elegant bridge structures founded on shaped piers and at a reasonable cost. Given that the four bridges account for only 30% of the total structures estimate, the resulting increase in total bridge budget is relatively modest when compared to the cheapest conforming solution approach.

The box girder bridge decks could be constructed by a number of methods including:

- Segmental construction where 2.5m – 3.5m wide full bridge width precast elements are lifted into position and post-tensioned together once all the units are in place.
- Cast insitu post tensioned box construction.
- A series of longitudinal spanning precast box beams. The outer beams would be cast with a curved profile to produce the desired shape.

3.3 BRIDGES 2 & 6

These bridges carry local roads over the NIMT rail line and are not highly visible from any adjacent vantage points. The railway alignment will be obscured in a cut at south Otaki and enters through a fill embankment at North Otaki. Both structures are relative short span in scale. Simple, robust and slim-line hollow core bridges are considered the sensible option for these bridges. Attention to detail (e.g. barrier and wingwall arrangement) should ensure a reasonable visual outcome with these bridges.

3.4 BRIDGE 9 – MARY CREST

The Mary Crest Bridge crossing carries the expressway over the NIMT rail line and a local access road. The crossing is particularly challenging as the road is highly skewed relative to the rail corridor below.

Alternatives investigated for this bridge included:

- Option 1 - A hollow core 'tunnel' similar to McKay's Crossing but much wider and longer
- Option 2 - A two-span steel composite bridge
- Option 3 - A day-lighted beam and slab deck (see drawings)

Initial estimates indicate that the cost of each of these options are similar.

The hollow core tunnel (Option 1) is a well understood and is an economic form. The down-side of this arrangement are the large 'dead areas' outside of the footprint of the carriageway making for a long and dark tunnel under the deck and unsightly areas of bridge deck beyond the footprint of the expressway above.

The two span composite steel bridge (Option 2) is made complex by a high skew angle increasing costs when compared to a square (zero skew angle) bridge. The structural depth required for this form of crossing (1.8 – 2m) is also considerably more than either the hollow core bridge (0.9 - 1.1m) or a beam and slab bridge (1.2 – 1.4m) making for more extensive earthworks and approach embankment heights. Although the bridge cost per square metre is high for this option, the bridge footprint matches the expressway above and the deck area is therefore smaller than for Options 1 & 3. All these factors deliver a bridge of similar overall cost to Options 1 & 3 providing the extra costs of the higher approach embankments is not included.

The beam and slab system (Option 3) proposed for this bridge structure is similar to Option 1 but with day-lighting of the structure not directly under the footprint of the expressway. The outcome is an attractive pergola effect at the portals of the bridge, a much brighter environment under the deck when compared to the hollow core tunnel, less materials as a result of the day-lighting and all at a similar cost to the hollow core or steel girder bridge options. Option 3 is therefore a clear winner for this bridge providing a cost effective, attractive bridge with a pleasant light environment for users travelling underneath.

3.5 BRIDGE 10 PEDESTRIAN/CYCLE EXTENSION TO THE EXISTING OTAKI RIVER BRIDGE

The logical form for this structure is a single 1m deep Super 'T' girder founded on new circular columns adjacent to the existing bridge piers. This provides a durable and economic structure that does not rely on the existing bridge for support. Seismic separation between new and old structures may need to be provided.

The 3m wide extension as proposed will need to be self supporting. This because the existing bridge is unlikely to have sufficient reserve strength capacity to carry an extension of this size.

It must be noted that a narrower extension constructed of much lighter structural steel, could possibly be supported by cantilever brackets fitted to the piers of the existing bridge. Feasibility of this option would require further investigation.



4.1 BRIDGE FORM

4.1.1 Superstructures

The recommended superstructure forms for the project bridges are as follows

Bridge No.	Bridge Name	Bridge Form
1	Waitohu Stream	Architecturally designed 3-span super "T",
2	Otaki North	Single span hollow core
3	Otaki North local road	2-span concrete box
4	Rahui Road	5-span concrete box
5	Otaki River Bridge	Architecturally designed 11-span Super "T"
6	South Otaki rail crossing	Single span hollow core
7	South Otaki expressway crossing	2-span concrete box
8	Te Horo	5-span concrete box
9	Mary Crest	Precast beam & slab bridge
10	Otaki River Bridge Extension	Super "T" on circular columns

Table 5: Bridge Forms

4.1.2 Substructures

Bridges founded on bored reinforced concrete piles are recommended for this project. This well proven foundation type delivers a robust and cost affective solution. All ten bridges in this project are detailed with bored piles.

4.2 EVALUATION AND SELECTION

The above solutions aim to deliver:

- Best value outcomes taking into account all relevant criteria including initial cost, whole of life considerations, community expectations and aesthetics.

For example, the proposed bridge at Mary Crest (bridge 9) is a very economic solution that is also an elegant bridge form turning what could of otherwise have been a chunky and dingy rail crossing into an interesting and airy rail and local road overbridge.

Sleek concrete box bridges are proposed for the local road over expressway underbridges (bridges 3, 4, 7 and 8). The bridges are more expensive than generally less attractive Super "T" bridges. The additional cost involved in providing a superior visual outcome at these locations is not considered

excessive in the context of the overall project. Again this is a 'best value' outcome.

- Robust bridges capable of withstanding large earthquakes.

Bridges 2, 3, 4, 6 – 9 are of fully integral construction. These structures have cast in-situ concrete connections between the superstructure components (deck and beams), and substructure (piers and abutments), which provide very good resistance to earthquake forces and potential ground movements.

Otaki River and Waitohu Stream Bridges (bridges 1 and 5) are founded on large diameter bored piles supporting reinforced concrete piers and abutments. This commonly used and proven structural form performs well in earthquakes with seismic resistance being provided by cantilever piers and pile/ pile cap bents.

- Good 'whole of life' performance.

Bridges 2, 3, 4, 6 – 9 are particularly low maintenance structures with no bearings and joints, or coating systems. Whole of life performance is expected to be excellent for these structures.

With careful detailing of the Waitohu Stream and Otaki River Bridges ensuring that good access and provision for bearing and joint repairs or replacement is provided, a reasonable 'whole of life' performance of these bridges is also anticipated.

- Local community acceptance.

Throughout the development of bridge concepts, the views of stakeholders have been sort and considered in the selection of form. The process has generally delivered outcomes that are visually acceptable, have stakeholder buy in and are still economic.

Rahui Road Bridge (bridge 4) is a prime example of successful stakeholder involvement. Many options were considered for the bridge with the final solution embraced by the stakeholders, being an affordable, sleek, soft and elegant concrete box bridge founded on shaped piers.

- Bridges that have good aesthetics.

Appropriate treatments have being adopted on a location-by-location basis. For instance, the highly visible underbridges (bridges 3, 4, 7 and 8) are sleek 'concrete box' style structures. Treatments to the piers and barriers are assumed for the larger river crossings (bridges 1 and 5). An attractive beam and slab bridge is proposed for the expressway over rail bridge (Mary Crest - bridge 9). No treatments are required for the local road over rail structures (bridges 2 and 6) as these are not particularly visible structures.



APPENDIX 1 – BRIDGE DRAWINGS

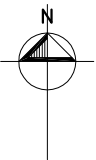

0
50
100
150
200
250
300
mm

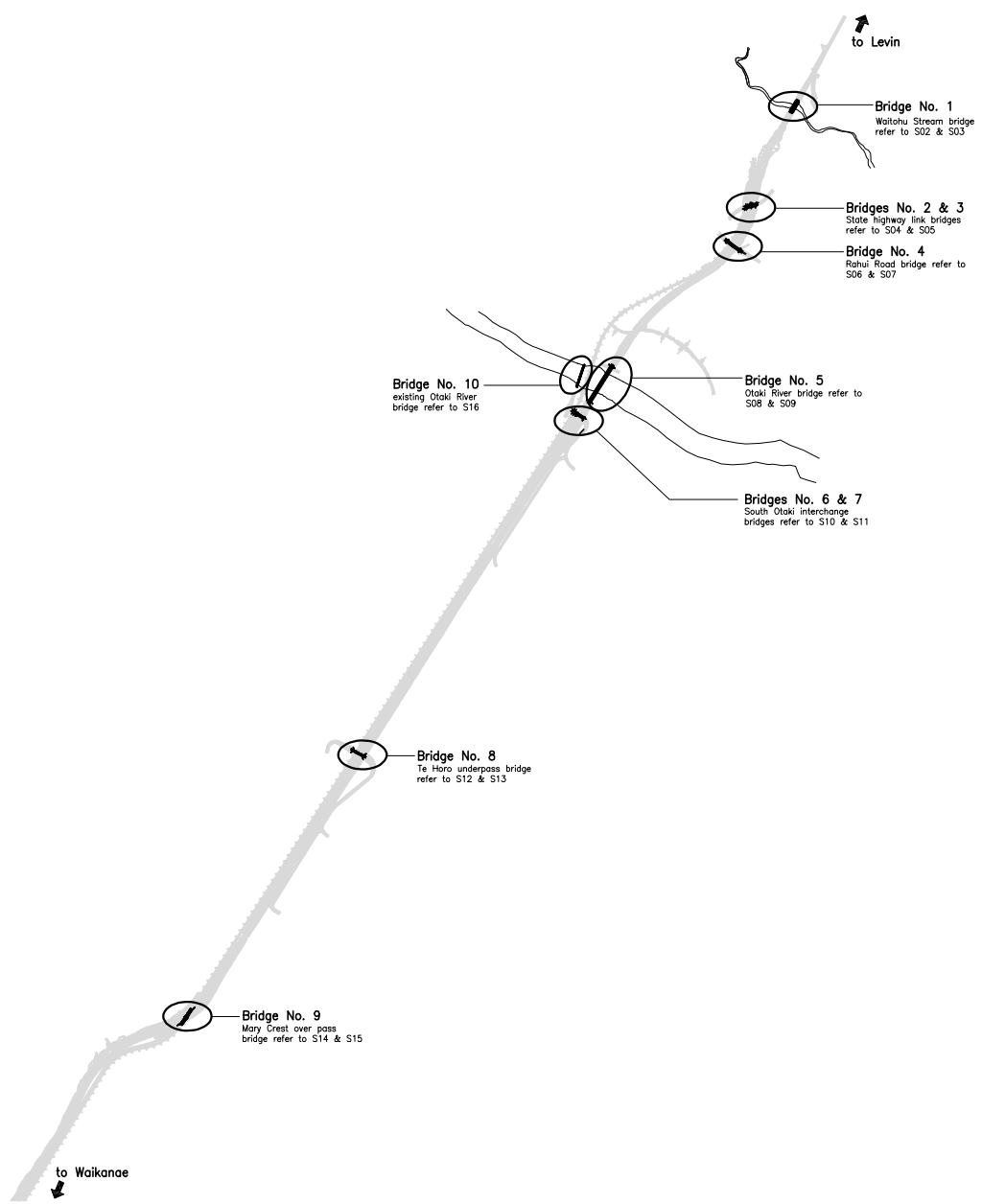

Revised	Amendment	Approved	Revised Date



Drawn	Designed	Approved	Revision Date
Project No.	Scale	Drawn No.	
5C1814.00	1:20000(A1)		

Project: NEW ZEALAND TRANSPORT AGENCY PEKA PEKA TO NORTH OTAKI EXPRESSWAY SCHEME ASSESSMENT			
Sheet: Structures Plans Bridges Location plan			
		Sheet No.	Rev/Min
		S01	

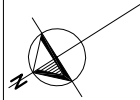

0 50 100 200 300 mm

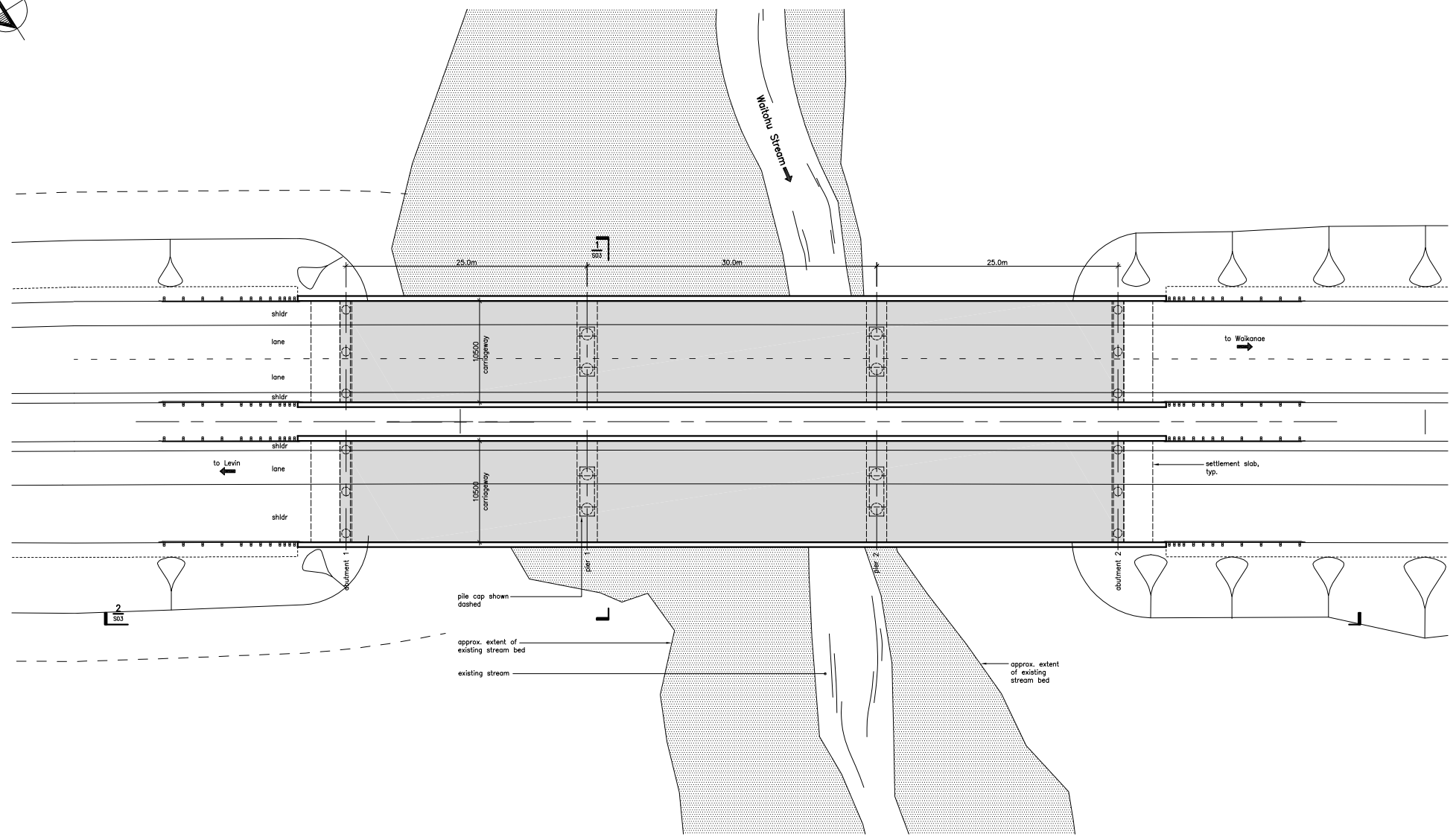

bridge general arrangement plan

Rev	Description	Approved	Revision Date



				Project: NEW ZEALAND TRANSPORT AGENCY PEKA PEKA TO NORTH OTAKI EXPRESSWAY SCHEME ASSESSMENT	
Drawn: _____ Designed: _____ Approved: _____ Revision Date: _____				Sheet: Structures Plans Bridge No. 1 Waitohu Stream plan	
Project No.: 5C1814.00		Scale: 1:200(A1)		Drawing No.: 104866-S02	
Original Sheet Size A1 [841x594] Plot Date				Sheet No.: S02	

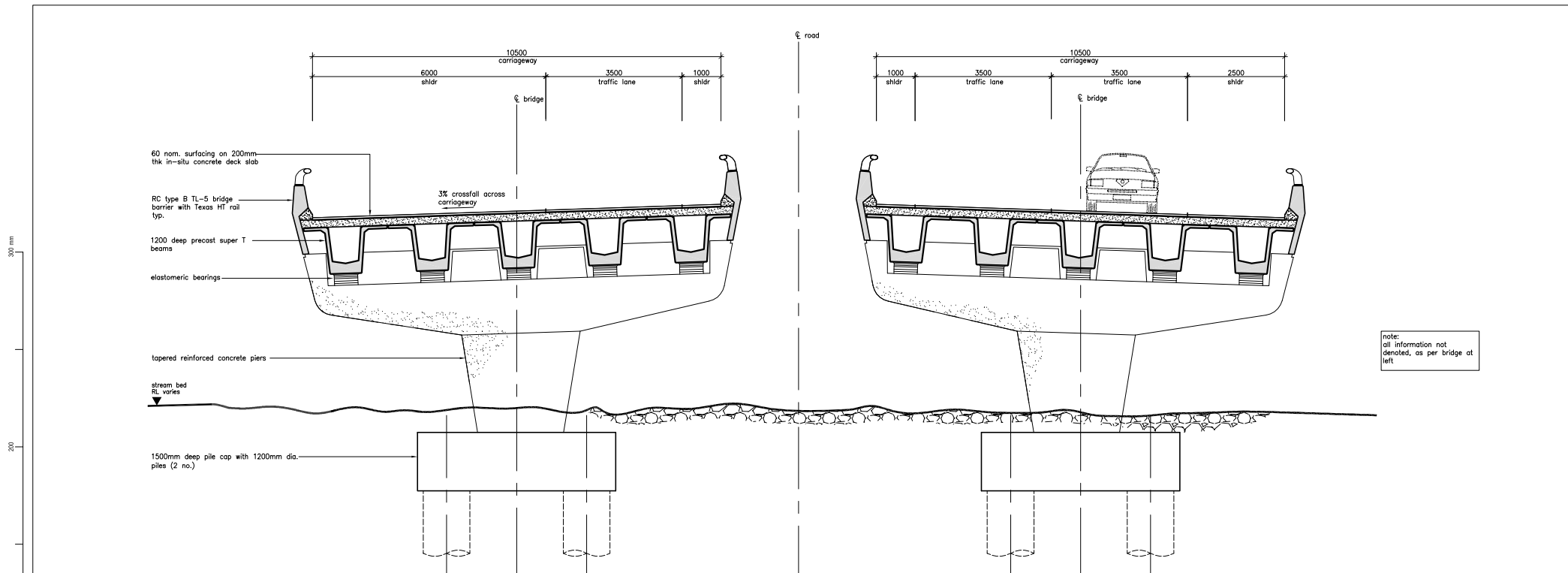

1
S02
bridge cross section at pier
1:50

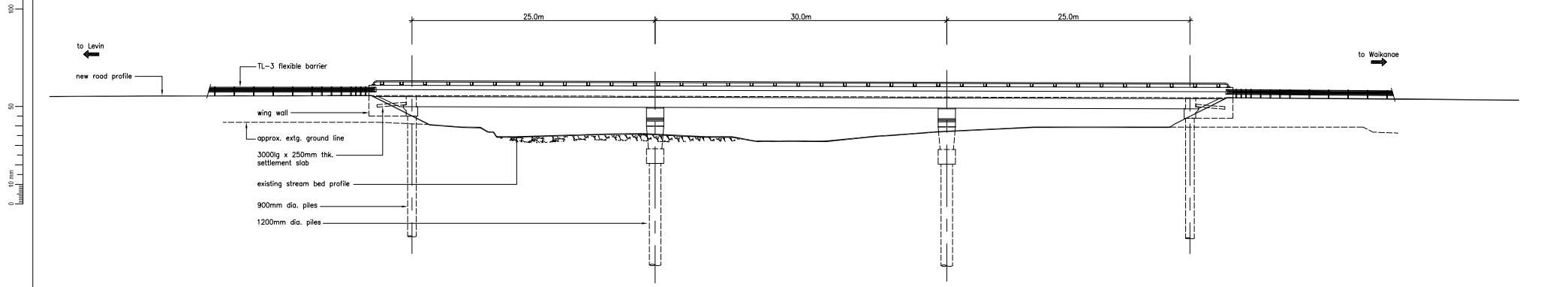

2
S02
bridge elevation
1:200

Revision	Amendment	Approved	Revision Date



Drawn	Designed	Approved	Revision Date
Project No.	Scale	Drawn No.	Revision
5C1814.00	As shown(A1)	104866-S03	S03

Project:
NEW ZEALAND TRANSPORT AGENCY
PEKA PEKA TO NORTH OTAKI EXPRESSWAY
SCHEME ASSESSMENT

Sheet:
Structures Plans
Bridge No. 1 Waitohu Stream section & elevation



0 20 40 60 80 100 120 140 160 180 200 220 240 260 280 300 mm

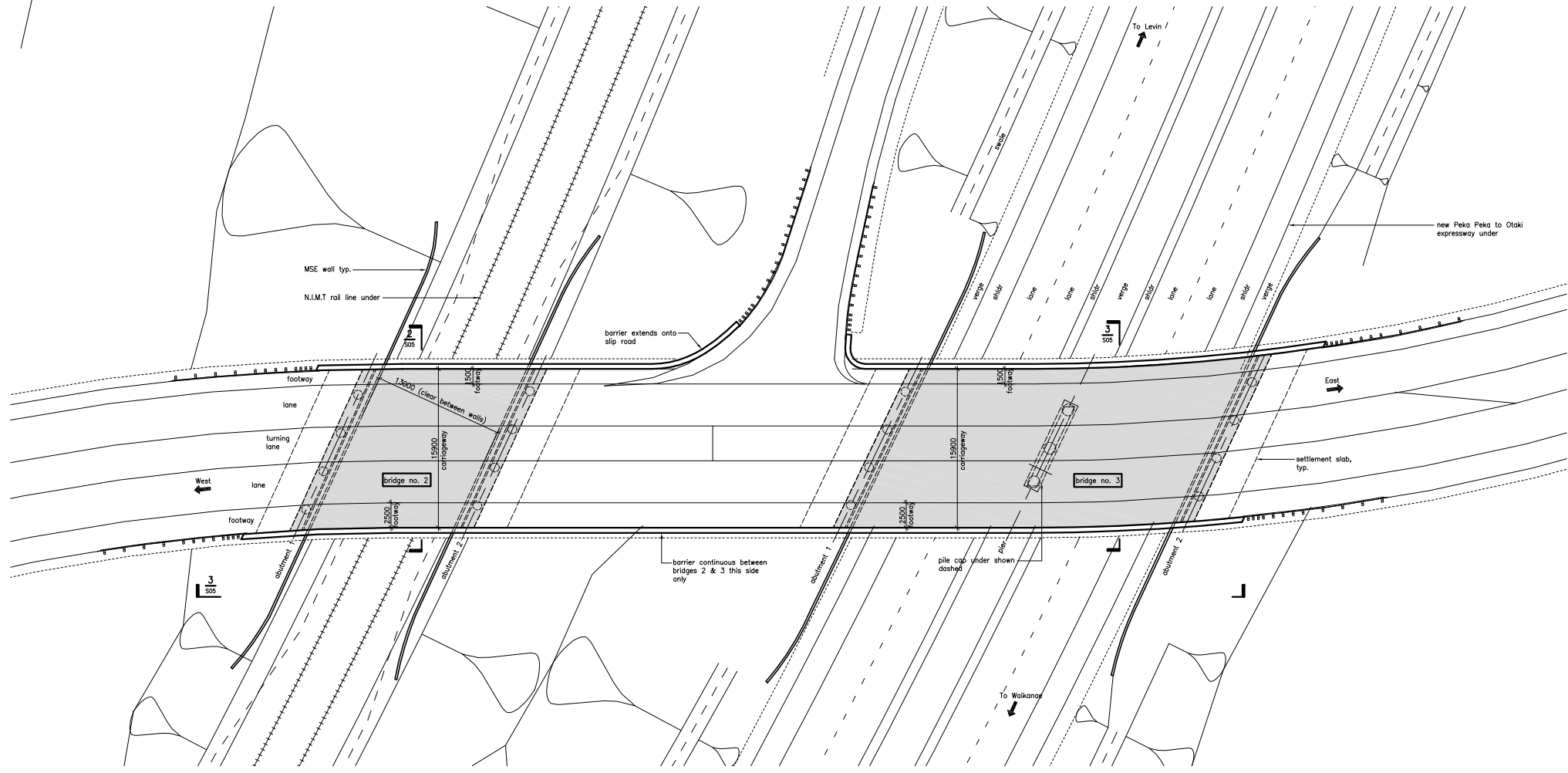

bridges general arrangement plan

Revision	Amendment	Approved	Revision Date



Project: NEW ZEALAND TRANSPORT AGENCY PEKA PEKA TO NORTH OTAKI EXPRESSWAY SCHEME ASSESSMENT			
Sheet: Structures Plans Bridges No. 2 & 3 North Otaki plan			
Project No. 5C1814.00	Scale 1:200(A1)	Drawing No. 104866-S04	Sheet No. S04

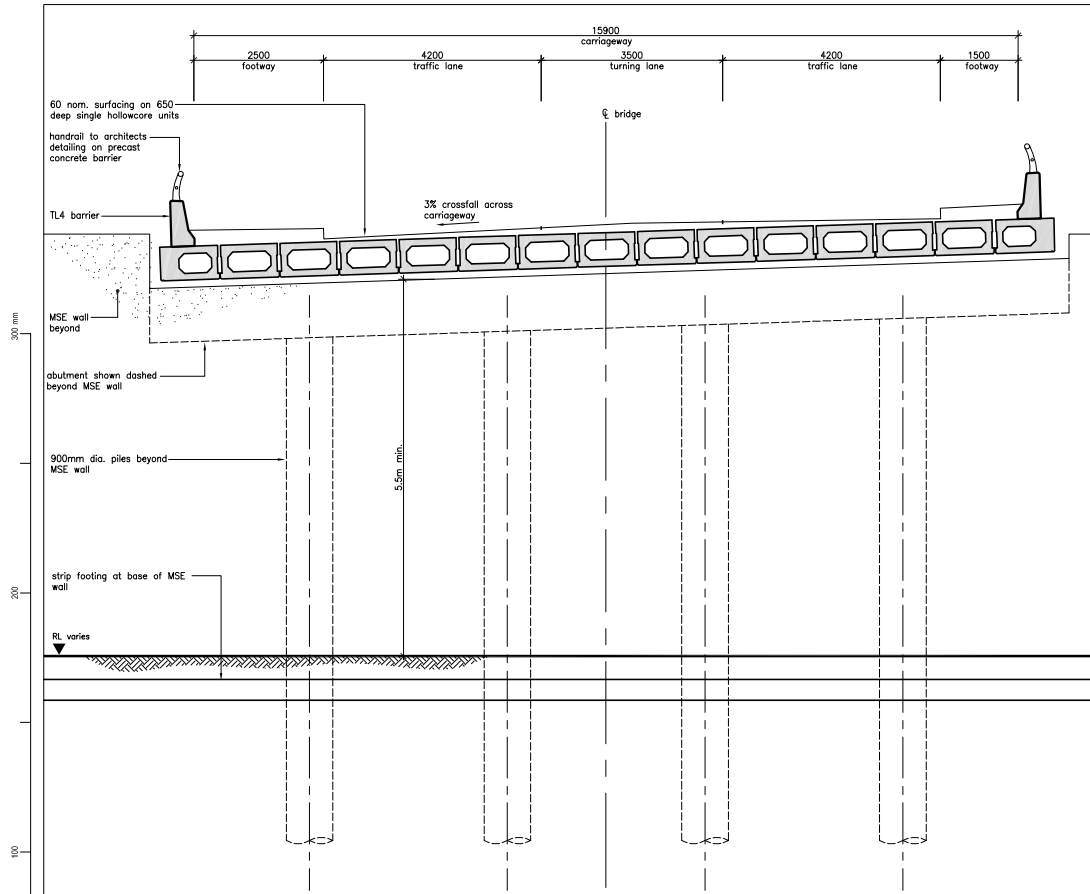

2
304
bridge 2 cross section
1:50

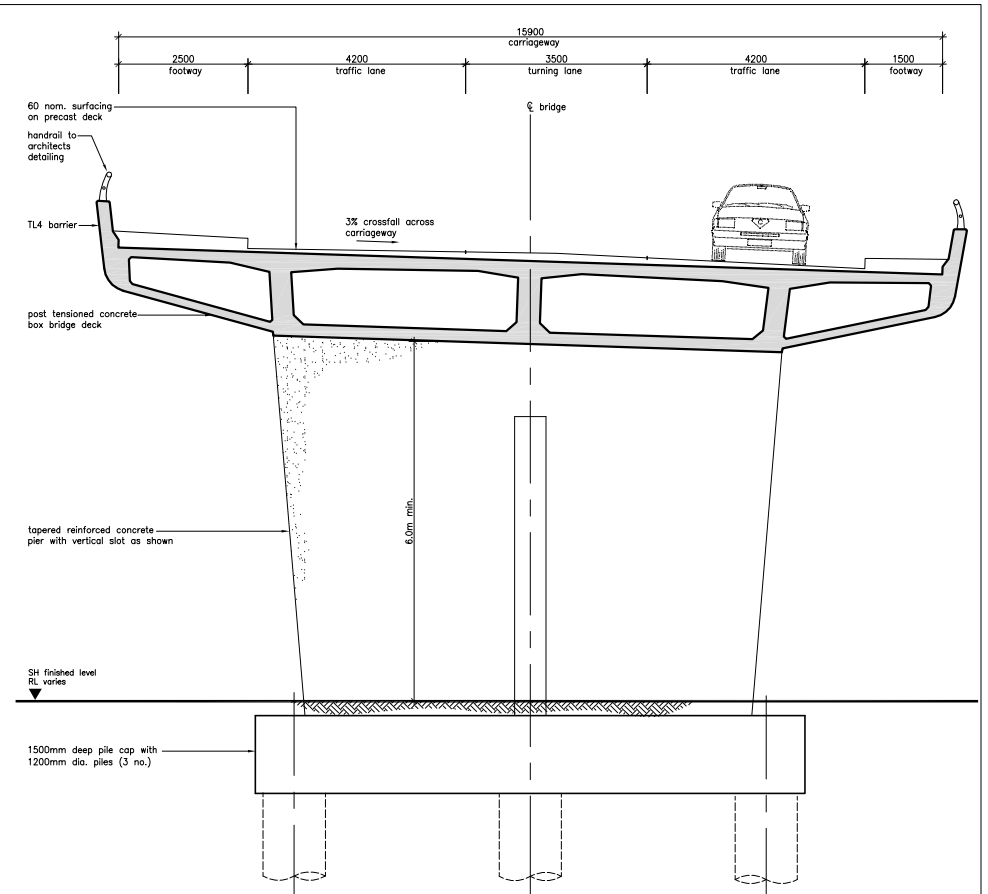

1
304
bridge 3 cross section at pier
1:50

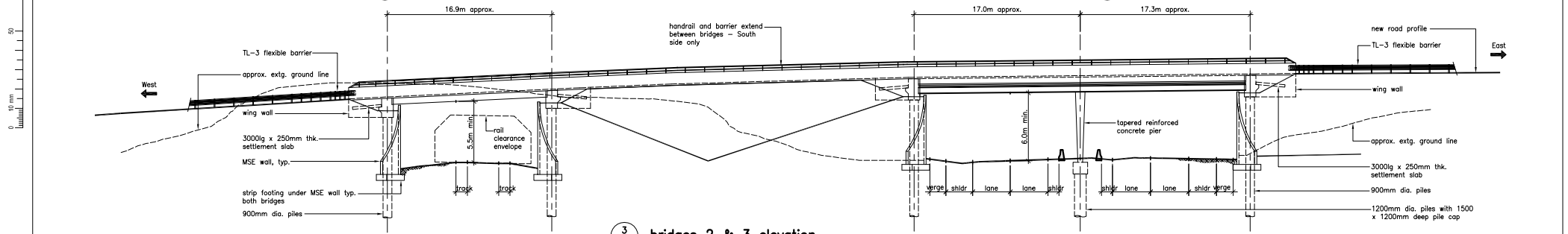

3
304
bridges 2 & 3 elevation
1:200

note:
protection barriers and screens over
rail corridor not shown but shall be
provided. Details pending discussions
with Kiwi Rail

Revision	Approved	Approved	Revision Date



Drawn	Designed	Approved	Revision Date

Project: NEW ZEALAND TRANSPORT AGENCY PEKA PEKA TO NORTH OTAKI EXPRESSWAY SCHEME ASSESSMENT			
Sheet: Structures Plans Bridges No. 2 & 3 North Otaki sections & elevation			
Project No.:	Scale:	Drawn No.:	Revision:
5C1814.00	As shown(A1)	104866-S05	S05

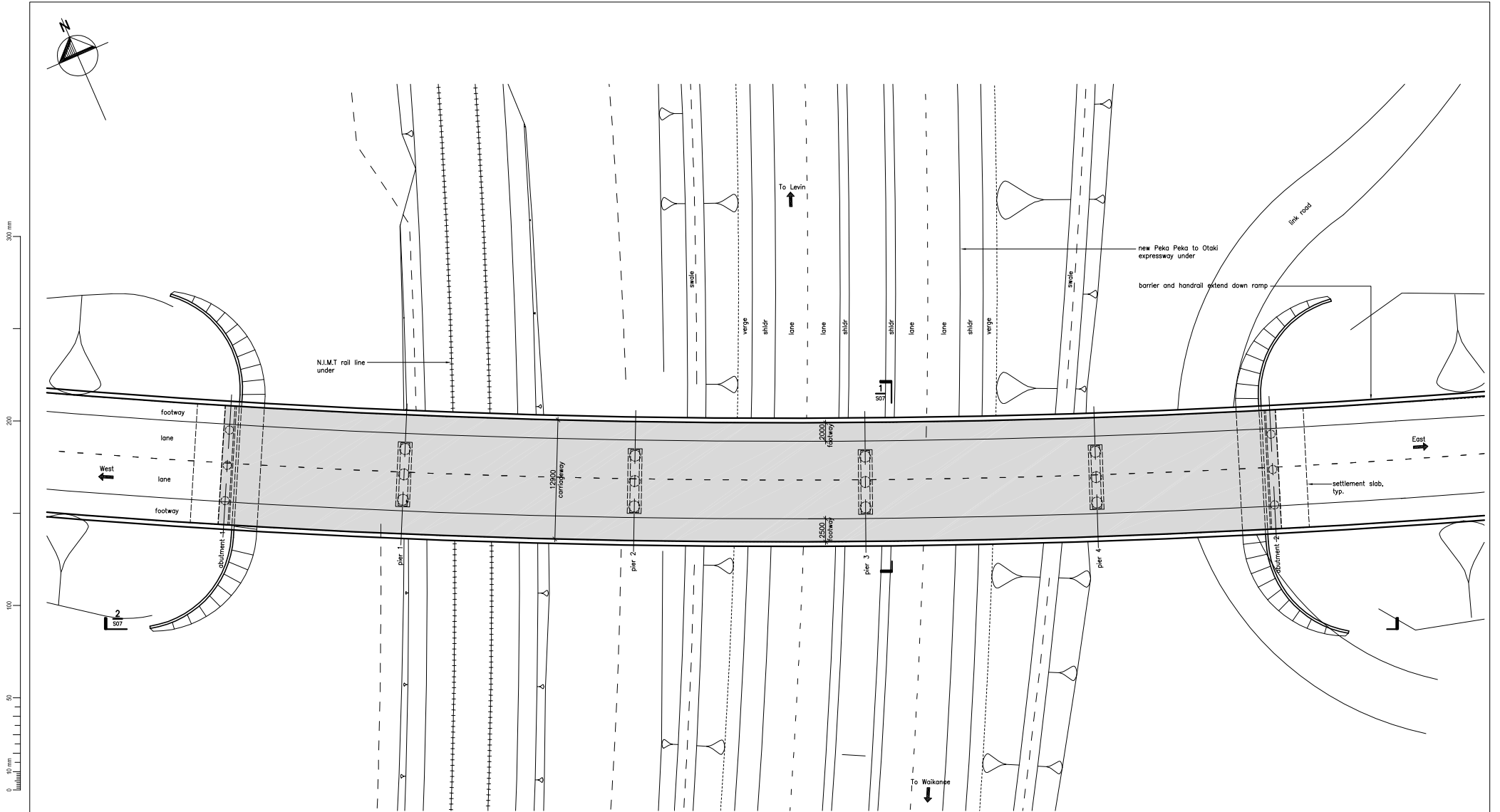

bridge general arrangement plan

Rev/Iss	Approved	Rev/Iss Date



Drawn	Designed	Approved	Revision Date
Project No.	Scale	Drawn No.	Rev/Iss
5C1814.00	1:200(A1)	104866-S06	S06

Project:
NEW ZEALAND TRANSPORT AGENCY
PEKA PEKA TO NORTH OTAKI EXPRESSWAY
SCHEME ASSESSMENT

Sheet:
Structures Plans
Bridge No. 4 Rahui Road plan

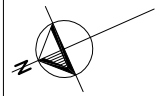

0 50 100 200 300 mm

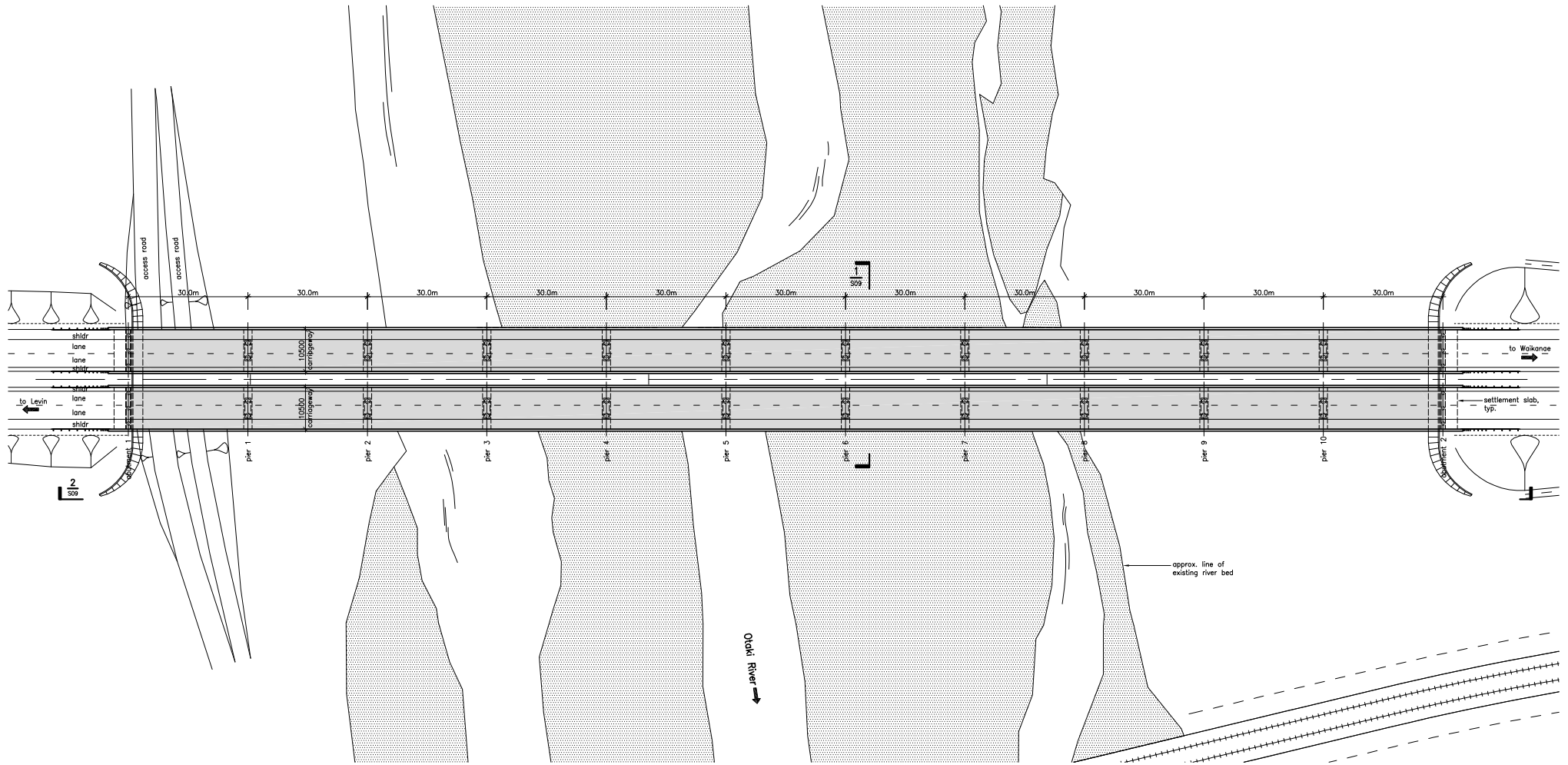

bridge general arrangement plan

Revision	Amendment	Approved	Revision Date



				Project: NEW ZEALAND TRANSPORT AGENCY PEKA PEKA TO NORTH OTAKI EXPRESSWAY SCHEME ASSESSMENT	
Drawn: Designed: Approved: Revision Date:				Sheet: Structures Plans Bridge No. 5 Otaki River plan	
Project No: 5C1814.00		Scale: 1:500(A1)		Drawing No: 104866-S08	
				Sheet No.: S08	
				Revision:	

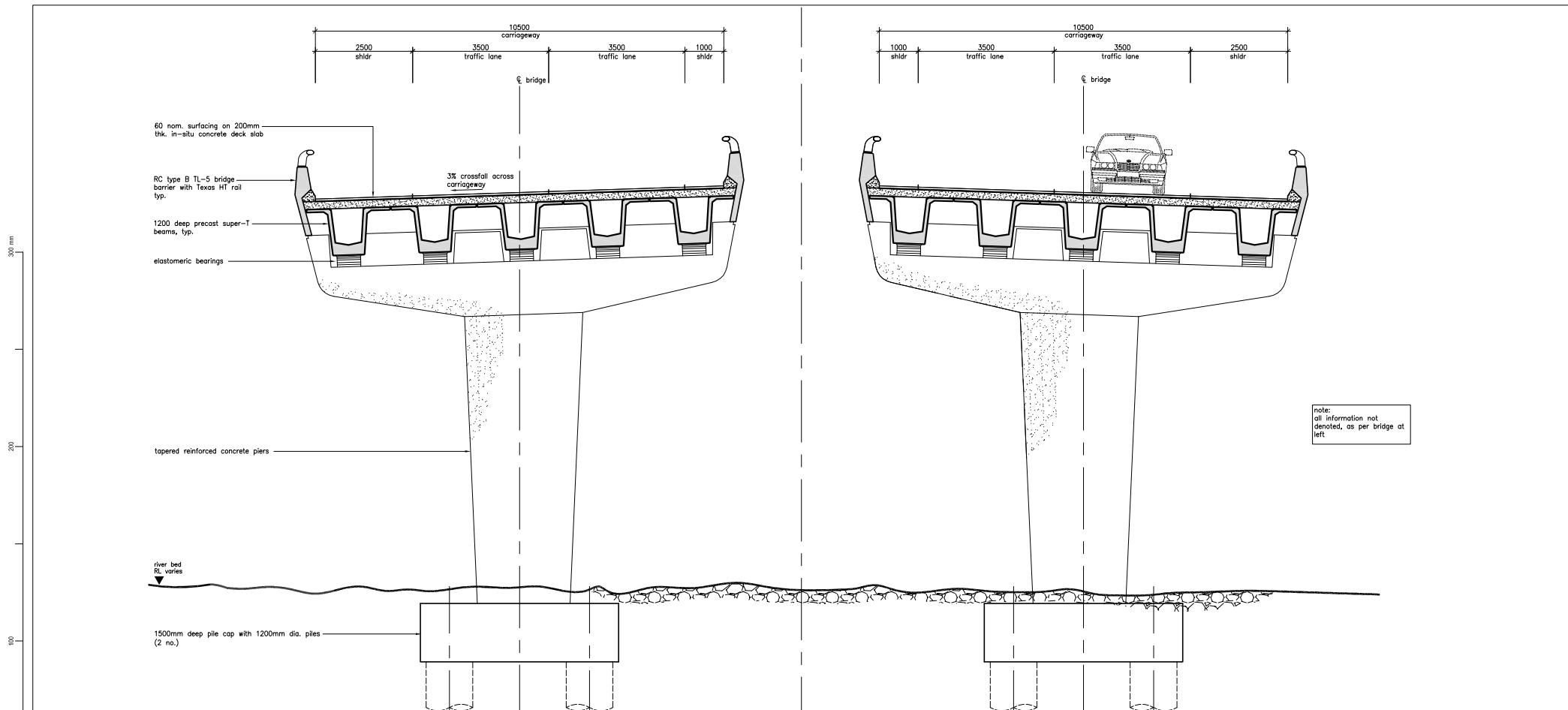

note:
all information not
denoted, as per bridge at
left

1
S08
bridge cross section at pier
1:50

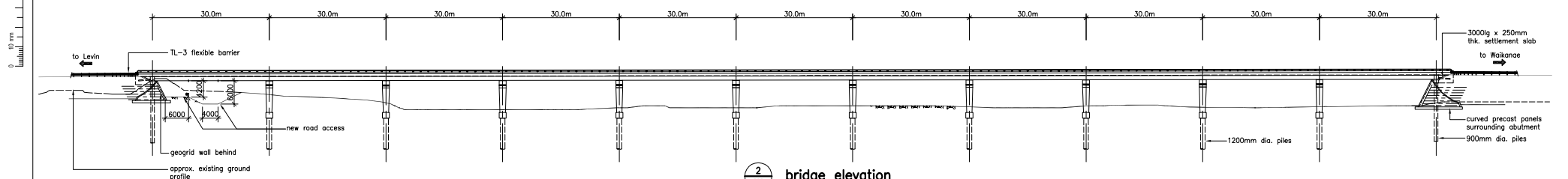

2
S08
bridge elevation
1:500

Rev	Amendment	Approved	Revision Date



Project: NEW ZEALAND TRANSPORT AGENCY PEKA PEKA TO NORTH OTAKI EXPRESSWAY SCHEME ASSESSMENT			
Sheet: Structures Plans Bridge No. 5 Otaki River section & elevation			
Project No. 5C1814.00	Scale As shown(A1)	Drawing No. 104866-S09	Sheet No. S09

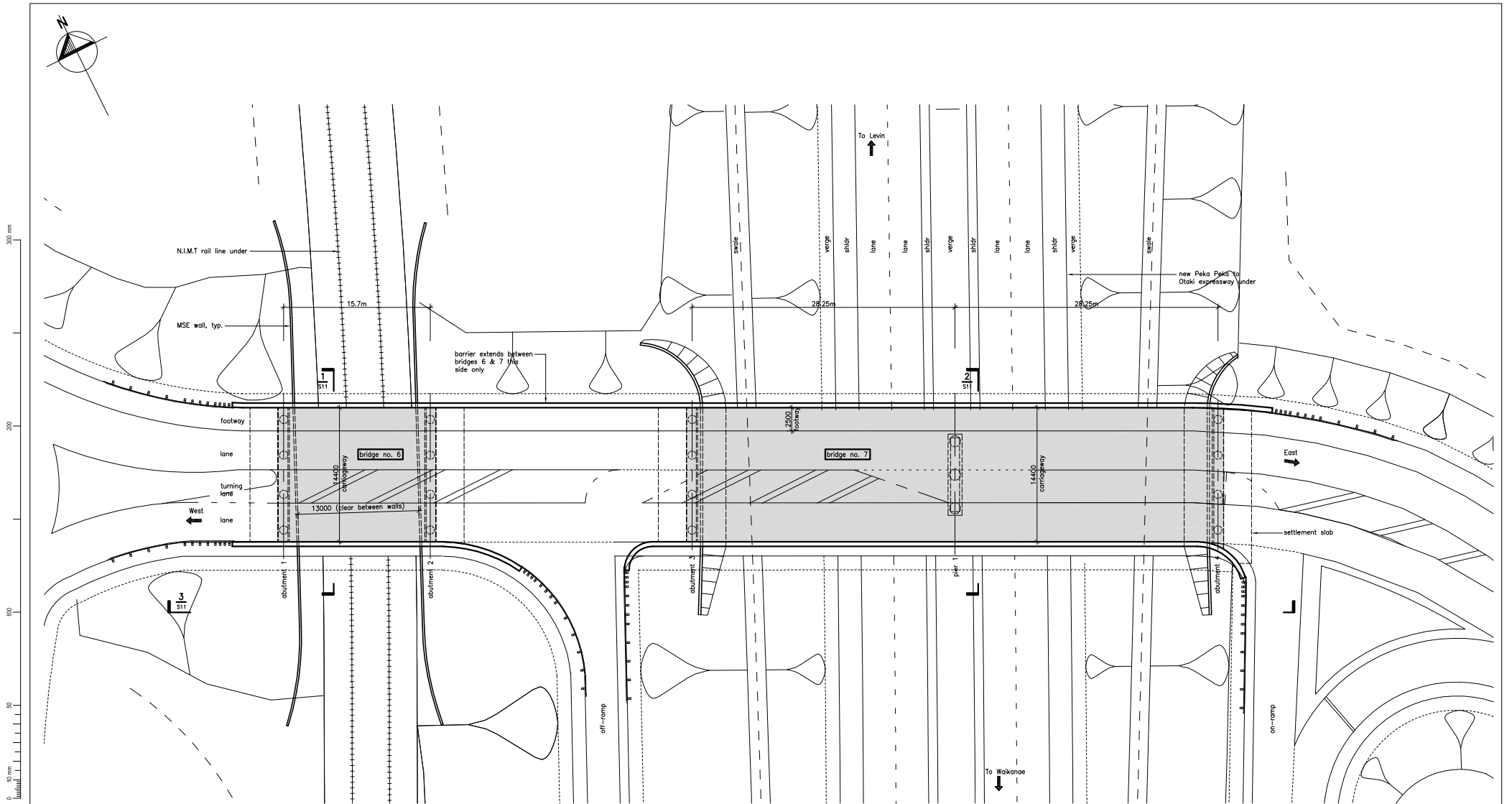

bridges general arrangement plan

Revision	Amendment	Approved	Revision Date



Project: NEW ZEALAND TRANSPORT AGENCY PEKA PEKA TO NORTH OTAKI EXPRESSWAY SCHEME ASSESSMENT			
Sheet: Structures Plans Bridges No. 6 & 7 South Otaki plan			
Project No. 5C1814.00	Scale: 1:200(A1)	Drawing No. 104866-S10	Sheet No. S10

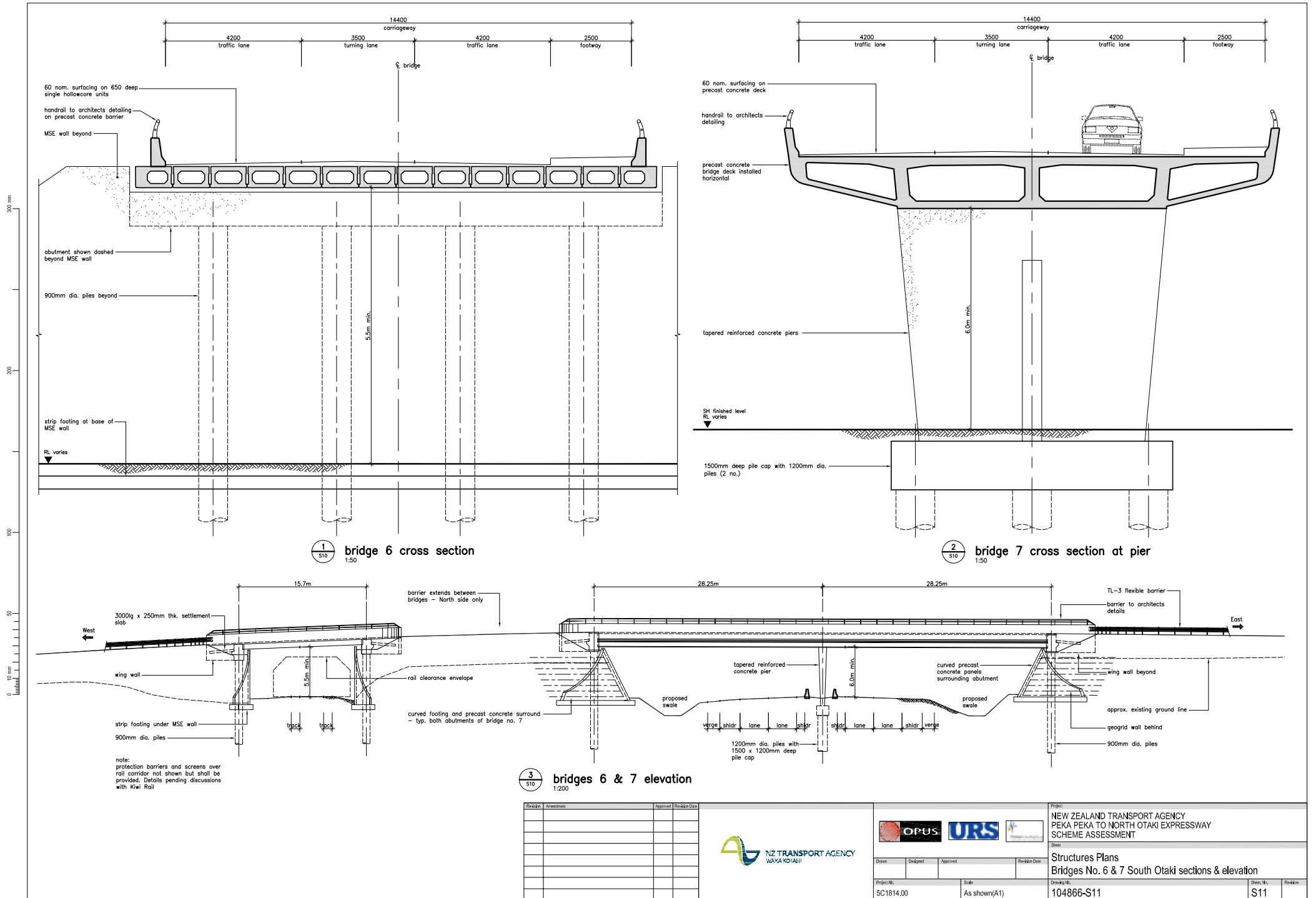

Revision	Amendment	Approved	Revision Date



				Project: NEW ZEALAND TRANSPORT AGENCY PEKA PEKA TO NORTH OTAKI EXPRESSWAY SCHEME ASSESSMENT	
Drawn: Designed: Approved: Revision Date:				Sheet: Structures Plans Bridges No. 6 & 7 South Otaki sections & elevation	
Project No.: 5C1814.00		Scale: As shown(A1)		Drawing No.: 104866-S11	
Original Sheet Size: A1 [841x594] Plot Date:				Sheet No.: S11	

300 mm
200
100
50
0
10 mm
millimetre

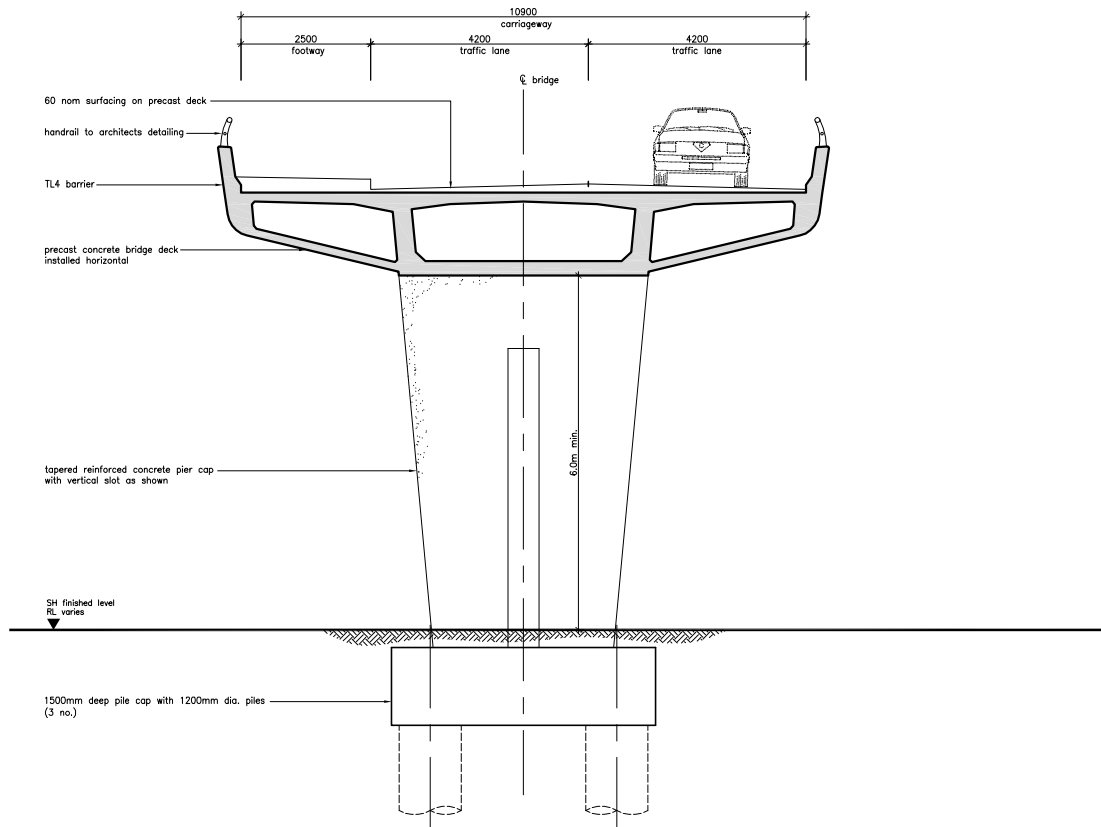

1
S12
bridge cross section at pier
1:50

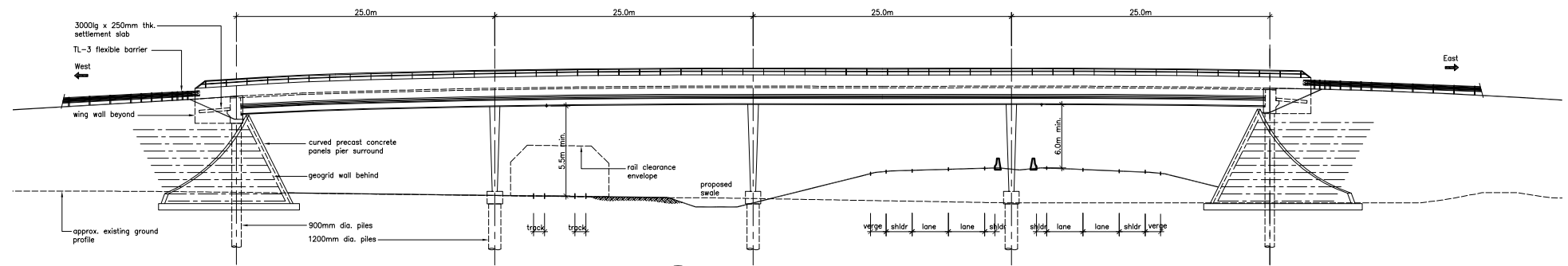

2
S12
bridge elevation
1:200

note:
protection barriers and screens over
rail corridor not shown but shall be
provided. Details pending discussions
with Kiwi Rail

Revison	Amendment	Approved	Revison Date



OPUS URS

Drawn	Designed	Approved	Revision Date

Project No. 5C1814.00 Scale: as shown(A1)

Project:
NEW ZEALAND TRANSPORT AGENCY
PEKA PEKA TO NORTH OTAKI EXPRESSWAY
SCHEME ASSESSMENT

Sheet:
Structures Plans
Bridge No. 8 Te Horo section & elevation

Project No.	Scale	Drawn No.	Sheet No.	Revision
5C1814.00	as shown(A1)	104866-S13	S13	

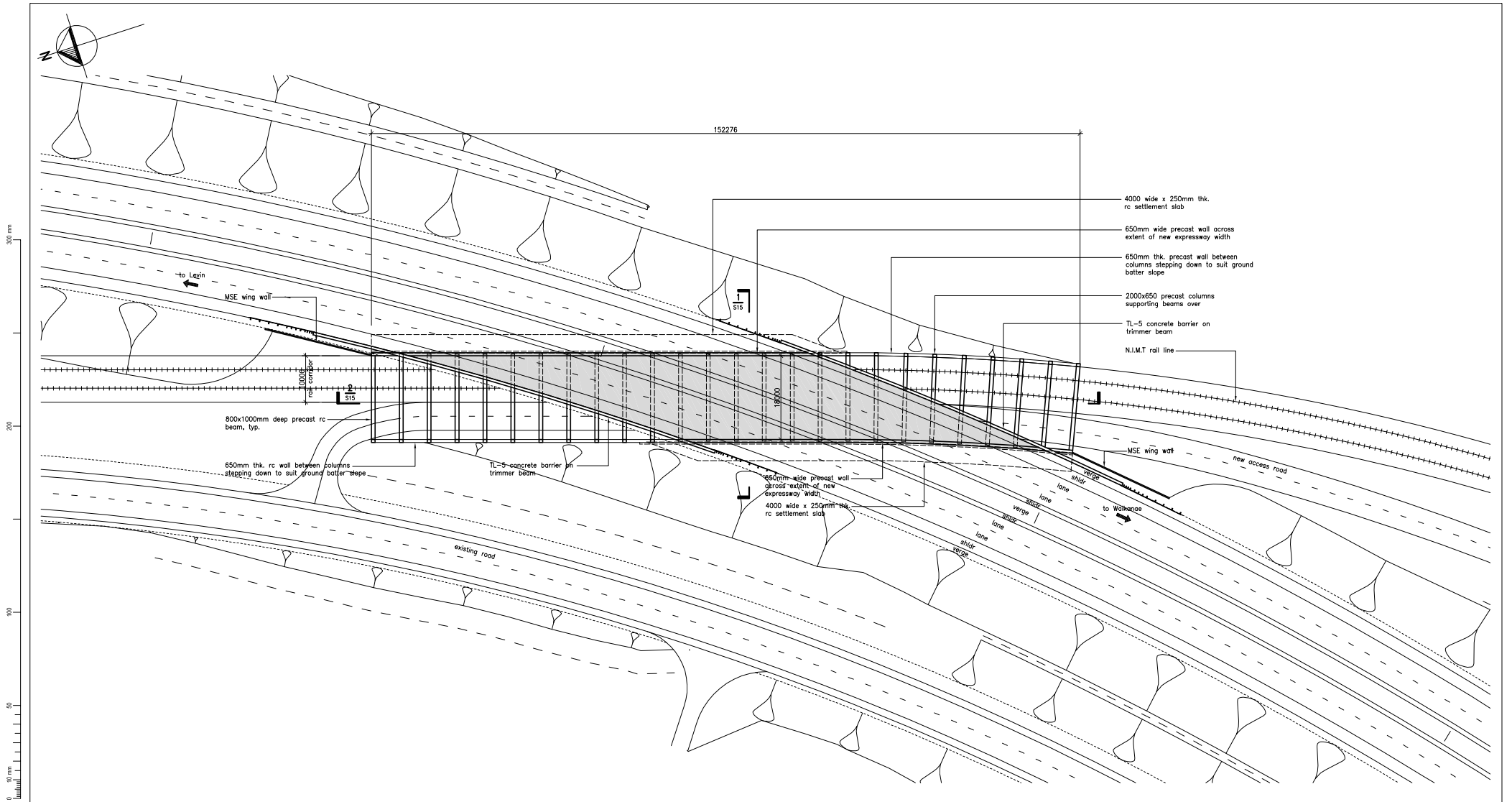

bridge general arrangement plan

Rev	Approved	Approved	Revision Date



Drawn	Designed	Approved	Revision Date
Project No.	Scale	Drawn No.	
5C1814.00	1:400(A1)		

Project: NEW ZEALAND TRANSPORT AGENCY PEKA PEKA TO NORTH OTAKI EXPRESSWAY SCHEME ASSESSMENT			
Sheet: Structures Plans Bridge No. 9 Mary Crest plan			
		Sheet No.	Rev
		S14	

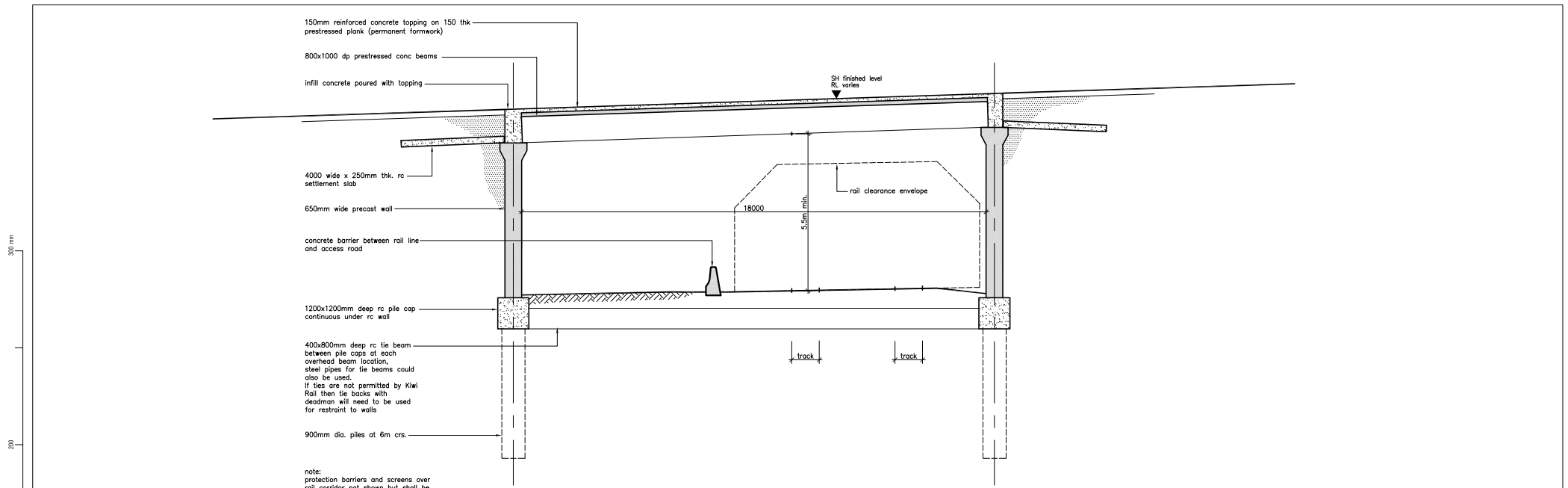

note:
protection barriers and screens over rail corridor not shown but shall be provided. Details pending discussions with Kiwi Rail

1 bridge cross section
S14 1:75

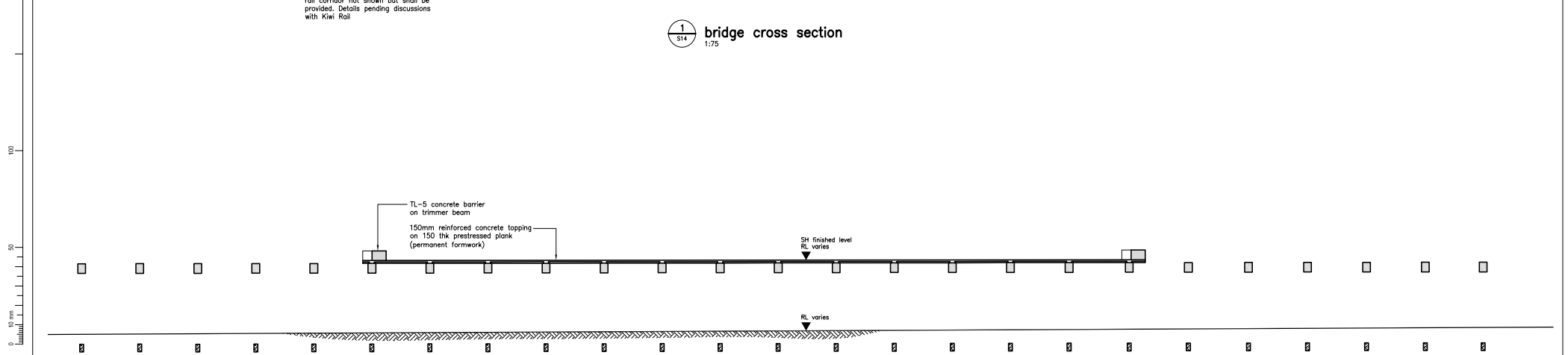

2 bridge long section along centreline of structure
S14 1:200

Revision	Amendment	Approved	Revision Date



Drawn	Designed	Approved	Revision Date
Project No.	Scale	Drawn No.	Revision
5C1814.00	as shown(A1)	104866-S15	S15

Project:
NEW ZEALAND TRANSPORT AGENCY
PEKA PEKA TO NORTH OTAKI EXPRESSWAY
SCHEME ASSESSMENT

Sheet:
Structures Plans
Bridge No. 9 Mary Crest section & long section

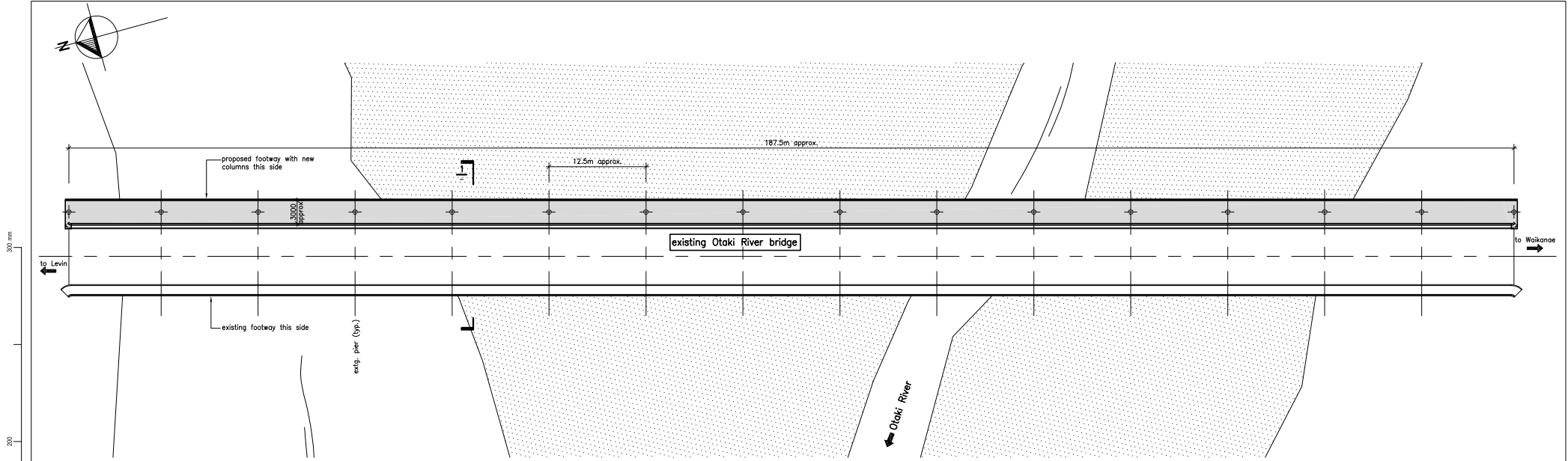

bridge general arrangement plan
1:250

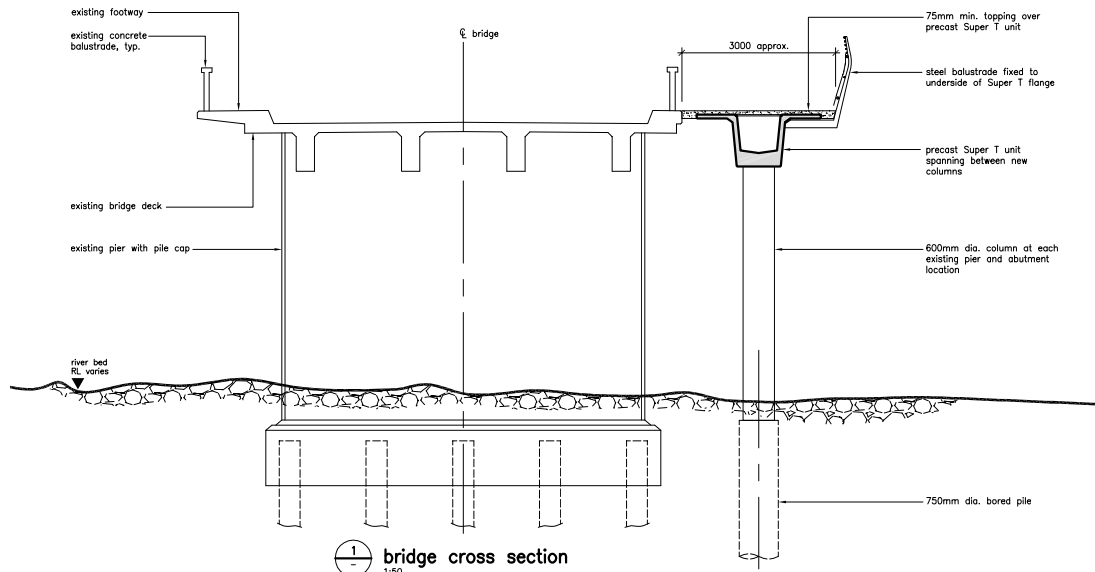

bridge cross section
1:50

Revision	Amendment	Approved	Revision Date



Drawn	Designed	Approved	Revision Date
Project No.	Scale	Drawn No.	Revision
5C1814.00	as shown(A1)	104866-S16	S16

Project:
NEW ZEALAND TRANSPORT AGENCY
PEKA PEKA TO NORTH OTAKI EXPRESSWAY
SCHEME ASSESSMENT

Sheet:
Structures Plans
Bridge No. 10 existing Otaki River new footway details