

---

# Site Specific Environmental Management Plan

## – Peka Peka to Ōtaki Project

**BR5B: Bridge 5 – Stage Two**

---

**FCCL-EV-MPN-0046**

---

August 2018 – Revision B.1

## Contents

|  |           |
|--|-----------|
| <b>Authorisation and Revision Record .....</b>           | <b>iv</b> |
| <b>Certification Record.....</b>                         | <b>iv</b> |
| <b>Authorisation and Revision Record .....</b>           | <b>v</b>  |
| <b>Certification Record.....</b>                         | <b>v</b>  |
| <b>1 Introduction.....</b>                               | <b>1</b>  |
| 1.1 Location of Works .....                              | 2         |
| 1.2 Description of Works .....                           | 3         |
| 1.3 Programme .....                                      | 4         |
| <b>2 Plan implementation.....</b>                        | <b>5</b>  |
| 2.1 Responsibilities .....                               | 5         |
| 2.2 SSEMP Changes.....                                   | 9         |
| <b>3 Works Methodology.....</b>                          | <b>9</b>  |
| 3.1 Site Access.....                                     | 9         |
| 3.1.1 North of the Ōtaki River.....                      | 9         |
| 3.1.2 South of the Ōtaki River.....                      | 9         |
| 3.2 Construction Plant .....                             | 9         |
| 3.3 Site Establishment and Temporary Road Diversion..... | 11        |
| 3.3.1 Quarrying and Transporting Materials.....          | 11        |
| 3.3.2 Disposal Sites .....                               | 11        |
| 3.3.3 Water Supply.....                                  | 11        |
| 3.4 Bored Piling .....                                   | 12        |
| 3.4.1 Changes to the Existing Rock Protection .....      | 12        |
| 3.5 Substructure.....                                    | 16        |
| 3.5.1 Column Construction .....                          | 16        |
| 3.5.2 Crossheads .....                                   | 16        |

|          |  |           |
|----------|--|-----------|
| 3.6      | Superstructure and Ancillary .....                                       | 16        |
| 3.6.1    | Construct abutment beams .....   | 16        |
| 3.6.2    | Beams and Bearing Placement .....  | 17        |
| 3.6.3    | Deck Construction .....  | 17        |
| 3.6.4    | Construction of Settlement Slab and Placement of Abutment Backfill ..... | 17        |
| 3.6.5    | Barrier Construction.....  | 17        |
| 3.7      | Final Earthworks.....  | 18        |
| <b>4</b> | <b>Environmental Management .....</b>                                    | <b>18</b> |
| 4.1      | General Pre-works Requirements.....                                      | 18        |
| 4.2      | Erosion and Sediment Control .....                                       | 18        |
| 4.3      | Bentonite and Concrete Management .....                                  | 19        |
| 4.3.1    | Bored Piling .....   | 19        |
| 4.3.2    | Deck Construction .....  | 19        |
| 4.4      | Ecological Requirements.....   | 20        |
| 4.4.1    | Banded Dotterels .....   | 20        |
| 4.5      | Water Quality Monitoring.....  | 20        |
| 4.6      | Cultural Monitoring.....   | 21        |
| 4.7      | Archaeology .....  | 21        |
| 4.8      | Noise and Vibration .....  | 22        |
| 4.8.1    | Pre-condition building surveys.....                                      | 23        |
| 4.9      | Air Quality .....  | 23        |
| <b>5</b> | <b>Stormwater / Flood Management .....</b>                               | <b>24</b> |
|          | Alert Level 1 .....  | 24        |
|          | Alert level 2.....   | 25        |
|          | Alert level 3.....   | 26        |
|          | Alert level 4 - 100 year return period expected .....                    | 27        |
| <b>6</b> | <b>Traffic and Public Safety .....</b>                                   | <b>28</b> |
|          | <b>Appendix A – SSEMP Authors .....</b>                                  | <b>28</b> |

**Appendix B – Consultation Record ..... 30**

**appendix C – Drawings ..... 31**

Layout Plan..... 32

Environmental Constraints Drawing ..... 33

Construction Drawings..... 34

**Appendix D – Programme ..... 35**

**Appendix E – Site Specific Traffic Management Plan ..... 36**

**Appendix F – Bridge 5 Flood Management Plan ..... 37**

## AUTHORISATION AND REVISION RECORD

| Revision | Status        | Author       | Date     | Description      |
|----------|---------------|--------------|----------|------------------|
| A        | Draft         | Alice Naylor | 08/08/18 | For Review       |
| A.1      | Updated Draft | Alice Naylor | 23/08/18 | For Review       |
| B        | Updated       | Alice Naylor | 18/09/18 | For Final Review |

### Certification Record

| Revision | Action             | Name | Position | Date | Signature |
|----------|--------------------|------|----------|------|-----------|
|          | Approved by:       |      |          |      |           |
|          | On behalf of KCDC: |      |          |      |           |

**CERTIFIED**  
 VIJAY SOMIA  
 Resource ConsentS & Compliance Manager  
 Kapiti Coast District Council  
 DATE: 19/09/2018



**Peka Peka to Otaki Expressway**  
Unit 2 & 3, 2 Ake Ake Place  
Otaki  
Wellington New Zealand

**Greater Wellington Regional Council**  
142 Wakefield Street  
Wellington  
11646 New Zealand  
Ph. +64 4 8030369

MAIL TYPE  
**General Correspondence**  
REFERENCE NUMBER  
FCCL-GCOR-002161

MAIL NUMBER  
GWRC-GCOR-000135

---

## Re: SSEMP BR5B - Bridge 5 - Stage Two Rev A.1

---

From Ms Alexandra McLeay - Greater Wellington Regional Council

To Alice Naylor - Fletcher Construction

Cc (4) Dave Rennison - Greater Wellington Regional Council  
Ms Sharyn Westlake - Greater Wellington Regional Council  
Mr Gregor McLean - Southern Skies Environmental Limited  
Mr Ants Ransley - Southern Skies Environmental Limited

Sent Wednesday, 3 October 2018

### MESSAGE

Hi Alice,

Due to the critical path status of these works, and the proposal for the GWRC Flood Protection and PP20 Design Team to workshop the remaining issues with the Bridge 5 Stage 2 SSEMP (Rev B) upon Sharyn's return from leave, we are comfortable issuing a partial certification for this SSEMP.

In this regard, I can advise that Richard Percy under delegated authority provides partial certification of SSEMP Bridge 5 Stage 2 (BR5B) Revision B (FCCL-EV-MPN-0046 - attached).

This partial certification allows commencement of the works for Pier 1 detailed in Sections 3.3 and 3.4 of the SSEMP, excluding Subsection 3.4.1. **All works described in the attached document that are highlighted red will not commence until approval is given by GWRC.**

Full certification of the SSEMP is withheld pending resolution of the remaining issues with the GWRC Flood Protection team.

When the flood protection issues are resolved and the SSEMP is ready for full certification we'll issue the signed certification page.

Please respond acknowledging acceptance of the above points, and get in touch with me with any questions (Dave and Richard are both out of the office today).

Kind regards,  
Alex

---

**From:** A Naylor  
**Sent:** 18/09/2018 5:46:59 PM NZST (GMT +12:00)  
**To:** Dave Rennison, Sharyn Westlake  
**Cc:** Alexandra McLeay  
**Mail Number:** FCCL-GCOR-002351  
**Subject:** Re: SSEMP BR5B - Bridge 5 - Stage Two Rev A.1

Hi Dave,

As per my email, see attached updated document and comments tracker. I have included all of Sharyn's comments from today also which have mostly been dealt with and responded to. As noted in my email, some are design queries regarding final details which I have asked the designers to deal directly with Sharyn on prior to issuing IFC drawings in October.

Let me know if you have any further queries.

Thanks

Alice Naylor

---

**From:** A Naylor  
**Sent:** 23/08/2018 5:22:31 PM NZST (GMT +12:00)  
**To:** Dave Rennison, Sharyn Westlake, Justine Gurr  
**Cc:** Alexandra McLeay, Tony Thomas  
**Mail Number:** FCCL-GCOR-002161  
**Subject:** SSEMP BR5B - Bridge 5 - Stage Two Rev A.1

Hi Justine / Dave,

Please find attached SSEMP BR5B 'Bridge 5 - Stage Two' Rev A.1 for your review.

We may now have piling resource earlier than planned so to make things as easy as possible for this review, I may look to schedule meetings next week to talk through the planned works and make sure we flag any potential issues (particularly regarding the GWRC Flood Team interface).

Sharyn - I will get a hard copy to you as soon as possible as requested.

Thanks  
Alice

# 1 INTRODUCTION

This Site Specific Environmental Management Plan (SSEMP) provides the necessary information to demonstrate how the project team plan to avoid or mitigate potential adverse environmental effects relating to construction of the Peka Peka to Ōtaki (PP2Ō) Expressway.

This document covers works to be undertaken north and south of the Ōtaki River to allow for the construction of the Ōtaki River Bridge (Bridge 5) through to final completion. The Bridge spans over the Ōtaki River, as well as the public and quarry access tracks along the northern bank of the river. It is located between chainage 3460 and 3793, east of the existing State Highway 1 (SH1) alignment and just north of the South Ōtaki Interchange.

Works on the southern side of the river are already underway including southern embankment earthworks, piling, column construction, crossheads and bridge beam placement between Pier's 3 and 9. Works currently underway are outlined in SSEMP BR5A 'Bridge 5 – Stage One' FCCL-EV-MPN-0021.

Table 1 below outlines the sequencing of works as outlined in the three SSEMPs that cover works relating to the Ōtaki River Bridge. At this stage, all works outlined in red are not to commence until these works have been released by GWRC in the form of written agreement or re-certification.

**Table 1: Overview of the SSEMP sequencing**

| SSEMP Bridge 5 Stage One (South) and associated changes  | SSEMP Bridge 5 Stage Two (North and South)   | SSEMP PW3  |
|--|--|--|
| Southern embankment earthworks   |  |  |
| South side piling (Pier's 3-9)   |  |  |
| Substructure: <ul style="list-style-type: none"> <li>Northern and southern abutments</li> <li>Column construction (Pier's 3-9)</li> <li>Crossheads (Pier's 3-9)</li> <li>Installation of bridge beams (south)</li> </ul> |  |  |
|  | Northern embankment earthworks   |  |
|  | North side piling (Pier's 1-2 and the northern abutment)   |  |
|  | Substructure: <ul style="list-style-type: none"> <li>Column construction (Pier's 1-2)</li> <li>Crossheads (Pier's 1-2)</li> </ul> Superstructure: <ul style="list-style-type: none"> <li>Beams, bearings, diaphragms, deck.</li> </ul> Ancillary: <ul style="list-style-type: none"> <li>Approach slabs, metal work, finishing works.</li> </ul> |  |
|  |  | Final landscaping, revegetation and road surfacing |



This SSEMP reflects the requirements of the Construction Environmental Management Plan (CEMP) and its appendices, and is intended to be utilised by the construction team to clearly identify any site specific environmental requirements that must be adhered to prior to, and during works. A suite of over-arching environmental management plans have been drawn from to inform the contents of this SSEMP. All works will be carried out in general accordance with these management plans.

Works are not to commence on site until certification of this SSEMP has been confirmed in writing by Kapiti Coast District Council (KCDC) and Greater Wellington Regional Council (GWRC).

Management plans referenced throughout this document are as follows:

**Table 2: PP2Ō Management Plans**

| Management Plan   | Status                             |
|---|------------------------------------|
| PP2Ō Construction Environmental Management Plan (CEMP)        | Complete and provided to KCDC/GWRC |
| PP2Ō Construction Noise and Vibration Management Plan (CNVMP) | Approved (KCDC)                    |
| PP2Ō Construction Air Quality Management Plan (CAQMP)         | Approved (KCDC)                    |
| PP2Ō Communications and Stakeholder Management Plan (SCMP)    | Approved (KCDC)                    |
| PP2Ō Erosion and Sediment Control Plan (ESCP)                 | Approved (GWRC)                    |
| Bulk Earthworks Contaminated Land Management Plan (BECLMP)    | Approved (GWRC)                    |
| Archaeological Management Plan                                | Approved                           |

## 1.1 Location of Works

Works will take place immediately north and south of the Ōtaki River. A precast concrete plant (Stresscrete) is located to the north-east with Winstones Aggregates Quarry to the north-west. The existing North Island Main Trunk (NIMT) railway line is located 100m west of the proposed Bridge with the existing SH1 located to the west of the railway line.

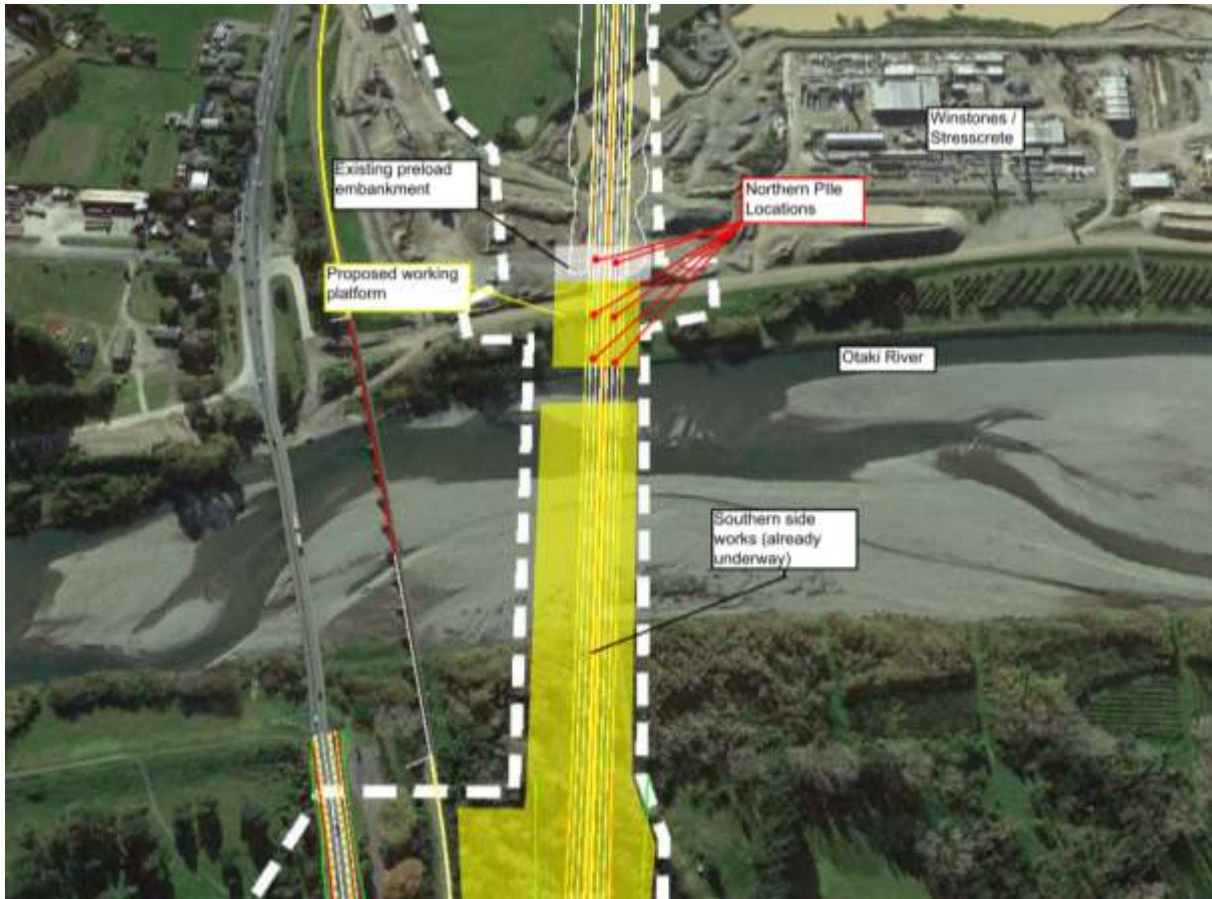

Figure 1: Location of works covered under this SSEMP (note southern side Stage One works are already underway).

## 1.2 Description of Works

The scope of works covered in this SSEMP is as follows:

- Construction of a temporary access diversion to the north of the site to be used by adjacent land users
- Site establishment on the northern side of the Ōtaki River
- Enabling earthworks to construct a level working platform between Pier's 1 and 2
- Bored piling (Pier's 1 – 2 and the northern abutment)
- Substructure
  - Column construction (Pier's 1 – 2)
  - Crossheads (Pier's 1 – 2)
- Superstructure (both north and south)
  - Bearings and beams
  - Deck construction
  - Barrier Installation
- Ancillary (both north and south)
  - Approach slabs
  - Metalwork
  - Miscellaneous finishing works including rock protection

- Final access routes and rock armouring

## 1.3 Programme

The expected programme for the activities covered by this SSEMP is as follows:

**Table 3: General Programme**

| Activity  | Commencement   | Duration  |
|---|----------------|-----------|
| Site establishment and temporary access diversion | September 2018 | 2 weeks   |
| Bored piling (Pier's 1 – 2 and northern abutment) | September 2018 | 1 month   |
| Column construction (Pier's 1 – 2)                | October 2018   | 2 months  |
| Crossheads (Pier's 1 – 2)                         | November 2018  | 2 months  |
| Superstructure (both north and south)             | September 2018 | 18 months |

A detailed programme can be found in Appendix D.

## 2 PLAN IMPLEMENTATION

### 2.1 Responsibilities

The following provides a summary of responsibilities relevant to the planning and implementation of this SSEMP.

| Role                  | Person        | Contact Details                        | Responsibilities   |
|-----------------------|---------------|--|--|
| Construction Manager  | Steve Findlay | stevef@fcc.co.nz<br>029 770 3128       | <ul style="list-style-type: none"> <li>Ensures there is a system in place so that construction works do not proceed until required environmental sign-offs are completed.</li> <li>Overviews systems and processes to ensure consent requirements are captured for construction works.</li> <li>Ensures adequate resources are provided to ensure environmental issues are appropriately managed.</li> <li>Reviews environmental incidents and complaints with the Environmental Manager and acts to address issues where needed.</li> <li>Reviews and monitors construction work methods to ensure compliance with RMA conditions</li> </ul>      |
| Environmental Manager | Alice Naylor  | A.Naylor@Higgins.co.nz<br>027 297 6055 | <ul style="list-style-type: none"> <li>Develops, implements and reviews environmental management systems and environmental management plans.</li> <li>Coordinates all environmental auditing functions and ensures relevant records are maintained.</li> <li>Responds to and investigates all environmental complaints, issues or incidents.</li> <li>Coordinates the SSEMP implementation process and pre-works requirements to ensure that environmental requirements are adhered to.</li> <li>Provides training and briefings to site staff to ensure that there is sufficient knowledge of environmental requirements in the field.</li> </ul> |

|                                      |                 |   |  |
|--------------------------------------|-----------------|---|--|
|                                      |                 |   | <ul style="list-style-type: none"> <li>• Acts as the primary point of communication between regulatory bodies and the project.</li> <li>• Coordinates a team of experts in specialist disciplines such as contaminated land, ecology, groundwater, noise and vibration.</li> <li>• Communicates environmentally sensitive areas to the construction team.</li> </ul>   |
| Environmental Coordinator            | Sevasti Hartley | sevastih@fcc.co.nz<br>0278078400          | <ul style="list-style-type: none"> <li>• Supports the Environmental Manager and provides leadership to ensure all staff comply with environmental management systems.</li> <li>• Provides support in the formation of SSEMPs.</li> <li>• Undertakes as-building of environmental controls.</li> <li>• Undertakes regular site inspections and audits.</li> <li>• Coordinates all site monitoring including but not limited to groundwater, water quality, ecological, dust, noise, and vibration monitoring.</li> <li>• Manages maintenance and monitoring of Chemical Treatment Systems (if used).</li> <li>• Ensures spill kits are available and stocked and provides training on equipment use.</li> <li>• Conducts regular site inspections of erosion and sediment control devices and co-ordinates maintenance where necessary.</li> <li>• Monitors site controls during rain storms.</li> <li>• Trains staff in site specific environmental procedures.</li> </ul> |
| Stakeholder & Communications Manager | Ed Breese       | ebreese@tonkintaylor.co.nz<br>021 333 726 | <ul style="list-style-type: none"> <li>• Organises, co-ordinates and facilitates engagement with affected property holders and community prior to and during construction.</li> <li>• Works in partnership with Environmental Manager on engagement and construction</li> </ul>  |

|  |  |  |   |
|--|--|--|---|
|  |  |  | activities in accordance with RMA conditions  |
| Site Superintendent / Supervisors / Foreman                          | Simon Fifield  | SimonF@fcc.co.nz<br>027 209 2295           | <ul style="list-style-type: none"> <li>• Provides leadership to the site construction team.</li> <li>• Ensures environmental controls including erosion and sediment control works are protected and maintained on a day to day basis.</li> <li>• Ensures that the SSEMPs and Archaeological Authority requirements are implemented appropriately by the construction team.</li> <li>• Maintains contactability 24/7 during construction and has authority to initiate immediate response actions.</li> <li>• Reports all environmental incidents, compliance issues and complaints to the Environmental Manager.</li> <li>• Reviews the need to use a water cart or sprinklers to control dust.</li> </ul> |
| Project Engineers  | Richard Rakovics (Civil)<br><br>Craig Service (Structural) | RichardR@fcc.co.nz<br><br>CraigS@fcc.co.nz | <ul style="list-style-type: none"> <li>• Responsible for ensuring environmental controls and erosion and sediment control works are installed and modified as appropriate for each stage of construction.</li> <li>• Develop, implements and monitors construction methods and environmental protection measures to ensure compliance with the SSEMPs.</li> <li>• Demonstrate understanding of major environmental and community issues and environmentally sensitive areas.</li> <li>• Coordinate environmental interfaces with subcontractors and suppliers.</li> <li>• Reports all environmental incidents, compliance issues and complaints to the Environmental Manager.</li> </ul>                    |
| Specialist support (contaminated land, ecology, noise and vibration) | Liz Deakin (Terrestrial Ecologist)                         | LDeakin@tonkintaylor.co.nz<br>027 568 1995 | <ul style="list-style-type: none"> <li>• Provide expert advice to the Environmental Manager and Environmental Coordinator regarding specific site requirements.</li> <li>• Submits reports to the Environmental Manager to fulfil requirements of consents relevant to their field.</li> </ul>  |

|     |  |   |   |
|-----|--|---|---|
|     | <p>Dean Miller<br/>(Principal Ecologist)</p> <p>Kathryn Longstaff (Avian Ecologist)</p> <p>Genevieve Smith – Contaminated land</p> <p>Brendon Shanks – Noise and Vibration</p> | <p>DCMiller@tonkintaylor.co.nz<br/>021542396</p> <p>KLongstaff@tonkintaylor.co.nz</p> <p>Genevieve.Smith@beca.co.nz</p> <p>Brendon.Shanks@marshallday.co.nz</p> | <ul style="list-style-type: none"> <li>Briefs the construction team of site specific requirements for environmentally 'sensitive areas'.</li> </ul>   |
| Iwi | <p>Te Waari Carkeek (Ngā Hapū o Ōtaki)</p>   | <p>TeWaariC@fcc.co.nz</p>   | <ul style="list-style-type: none"> <li>Provide input into project documentation such as management plans, design processes, planning documents.</li> <li>Reviews permits to work and coordinates the level of involvement of kaitiaki in site activities</li> <li>Coordinates all aspects of iwi monitoring.</li> <li>Key point of contact for Ngā Hapū o Ōtaki.</li> </ul> |
|     | <p>Caleb Royal (Ngā Hapū o Ōtaki)</p>  |   | <ul style="list-style-type: none"> <li>Reviews consent applications and coordinates cultural monitoring activities.</li> <li>Provides specialist advice to Ngā Hapū o Ōtaki</li> </ul>  |
| Iwi | <p>Muaupoko Tribal Authority</p>   |   | <ul style="list-style-type: none"> <li>Point of contact for any archaeological discoveries in accordance with the agreed accidental discovery protocols and MTA agreement.</li> </ul>   |

## 2.2 SSEMP Changes

In the event that changes in works scope or methodology are required, changes may need to be made to this document in accordance with resource Consent Condition's DC.18B and / or G.21A. Any 'major' changes will be submitted to the respective Manager for certification at least 5 working days prior to implementation of that change.

In accordance with Condition G.21A, a 'minor change' may be submitted to the Manager for certification at least 2 working days prior to implementation of that change, unless an alternative process of approving a 'minor change' is agreed to by the Manager, Greater Wellington Regional Council.

# 3 WORKS METHODOLOGY

## 3.1 Site Access

### 3.1.1 North of the Ōtaki River

Access to the site will be from the west via the existing shared access under the SH1 Bridge. All vehicle movements and traffic arrangements will be coordinated in consultation with other users. Refer to the Site Specific Traffic Management Plan drawings outlined in Appendix E for further details.

### 3.1.2 South of the Ōtaki River

The existing access/egress point will be utilised for these works from Ōtaki Gorge Road (SAP-10).

The access/egress points will be stabilised using clean aggregate or sealed to avoid any construction related material leaving the site. Any migration of material from the site onto the local road or footpath will be removed immediately.

Stormwater from the local road reserve will not be impeded by vehicle crossing during and after construction and any damage made to road infrastructure as a direct result of these works shall be recorded and repaired immediately.

## 3.2 Construction Plant

The plant items to be used to undertake each of the activities will generally be as follows:

### Enabling Earthworks

- 6 – 20T excavators
- Dozers
- 12T roller
- Truck and trailers
- Dump trucks
- Water carts as required



- Light vehicles

### **Piling Works**

- RT3 Drill Rig on Crawler Crane
- Service Crane
- Mobile cranes
- Bentonite mixers and plant
- PTC60 Vibro hammer
- Drilling buckets
- Auger
- Clam shell attachment

### **General Structural Works**

- 350T crane x 2
- 20T excavator
- Concrete pump
- 30T crane
- Franner crane
- Merlo
- Hiab
- Light vehicles
- Trucks

All plant will require to be inspected prior to start of works and during construction activities at regular intervals. Unwanted vegetation, seeds or contaminants will be cleared prior to plant entering the site to avoid the introduction or spread of weeds or pest species.

Plant inspections will be recorded on daily plant inspection forms to demonstrate that all plant used on this project are in good working order and have been cleared of unwanted weeds and pest species. Any faulty equipment will be stood down until the necessary repairs are carried out and the given plant is fit for purpose.

General spill control kits will be available on site at all times. A site-specific spill kit will also be available in the event of a spill to the Ōtaki River including an appropriate river boom to deploy if necessary. Refuelling activities will take place using a mini-tanker at least 10m away from the river to prevent additional risk of spillage to the river, with storage of any mini-tankers at Bridge Lodge Compound outside of the flood plain.

## 3.3 Site Establishment and Temporary Road Diversion

Prior to piling activities commencing at Pier's 1 and 2, the following site establishment works will take place:

- Construction of a temporary road diversion to the north to allow ongoing traffic movements for the adjacent businesses and public access safely around the site.
- Topsoil will be stripped from within the Designation footprint between the River's edge and the northern embankment (refer to Appendix C layout drawings).
- Suitable gravel material will be imported to construct a working platform.
- The existing river rock protection along the northern bank of the river at one of the Pier 2 pile locations (Pile 21), will be extended out by approximately 2m to the south to allow for piling in this location. Refer to section 3.2.1 for additional details and final remedial works.
- A gravel ramp will be constructed from the platform to the top of the northern embankment preload (already constructed) to allow access to the pile locations at a later date.
- Upon completion of the settlement period for the northern embankment preload, surcharge material will be removed and carted north to the existing stockpile location within Designation immediately north of the Winstone Aggregates yard.
- Mobilisation of plant and equipment from the south side of the river to the north. Note that worker conveniences and sign-in sheds will be located on higher ground near to the bentonite tanks to ensure that they are protected in the event of a flood.

### 3.3.1 Quarrying and Transporting Materials

Fill material required for the platform will be sourced from an off-site Quarry.

### 3.3.2 Disposal Sites

A temporary stockpile will be located between the existing northern preload embankment and the proposed temporary access road. All other surplus material (i.e. pile cuttings and soft unsuitable material) will be transferred to the existing stockpile location within the Designation north of Winstone Aggregates yard. Access to this northern stockpile location will be arranged prior with Winstones Aggregates.

### 3.3.3 Water Supply

Construction water required for these works will likely be collected from off-site sources. Water will not be taken from GBC Winstone bores and new bores are not planned to be constructed for these works.

## 3.4 Bored Piling

A total of six 2.1m piles will be completed under this SSEMP (Pier's 1, 2 and the northern abutment piles). Each pile is expected to take approximately one week and will be carried out as follows:

- Prepare pile for construction
  - Install outer 3m diameter oversized casing to contain any overflow and provide stability when inner casing is extracted. This will be 3m long and embedded 1.5m into the ground with 1.5m protruding above ground.
  - Excavate material to top of pile (RL of 9.5m)
  - Setup column plunge jig
- Install 2.1m casing at pile location using vibro-hammer. The top of this casing will extend to RL +13m.
- Bore piles with bentonite, maintaining bentonite 1.5m above groundwater level.
- Drill cuttings will be transferred to one of the two allocated disposal sites (refer to 3.1.2)
- Install pile reinforcing cage
- Concrete pile by tremmie, as the concrete comes up, pump bentonite from the top of the pile back to the bentonite plant.
- Remove temporary casing
- Setup remaining items for column plunge jig
- Plunge column cage
- Remove column plunge arrangement
- Repeat above for remaining columns

### 3.4.1 Changes to the Existing Rock Protection

Prior to piling at Pier 2, the existing rock protection that is in place along the northern bank of the river will be extended / altered locally at one of the Pile locations (eastern pile) to allow for piling and a suitable working area. As-built information of the existing extent of rock armouring is available to the project team. Upon completion of the works in this location, the rock will be re-instated by the project back to its existing pre-works state. As-built records will be provided to GWRC Flood Team upon completion. The alterations will be carried out with input from the GWRC Flood Team to ensure that any changes are managed carefully and to do not result in additional erosion of the river bank.

The proposed methodology for locally altering the rock wall is proposed as follows:

- A test pit will be excavated to determine the extent of rock.
- Once the extent of rock has been determined, an excavator will work from the northern bank to expose the larger rock located within the pile location. This rock will be removed from the pile location and temporarily placed to the side.
- Clean gravels will be used to backfill the hole created at the pile location.
- Clean gravels will be used to extend a working platform out approximately 2-3m into the river from the existing rock edge and approximately 10m in length along the bank.

- The larger rock that was excavated from the rock wall will then be used to armour the upstream outer edge of the newly created groyne.
- Due to the restricted space in this location and the underlying gravels, stacked sandbags will be the preferred environmental control to be placed along the edge of the platform at this pile location. The piling platform will be maintained as clean as far as practicable with sandbags only used as a contingency in the event of small spills at the pile location.
- The groyne work will not be carried out until the platform that currently extends out to Pier 3 from the south is reduced down to RL 10.5m. This will widen out the main channel and reduce the risk of erosion of the rock line.

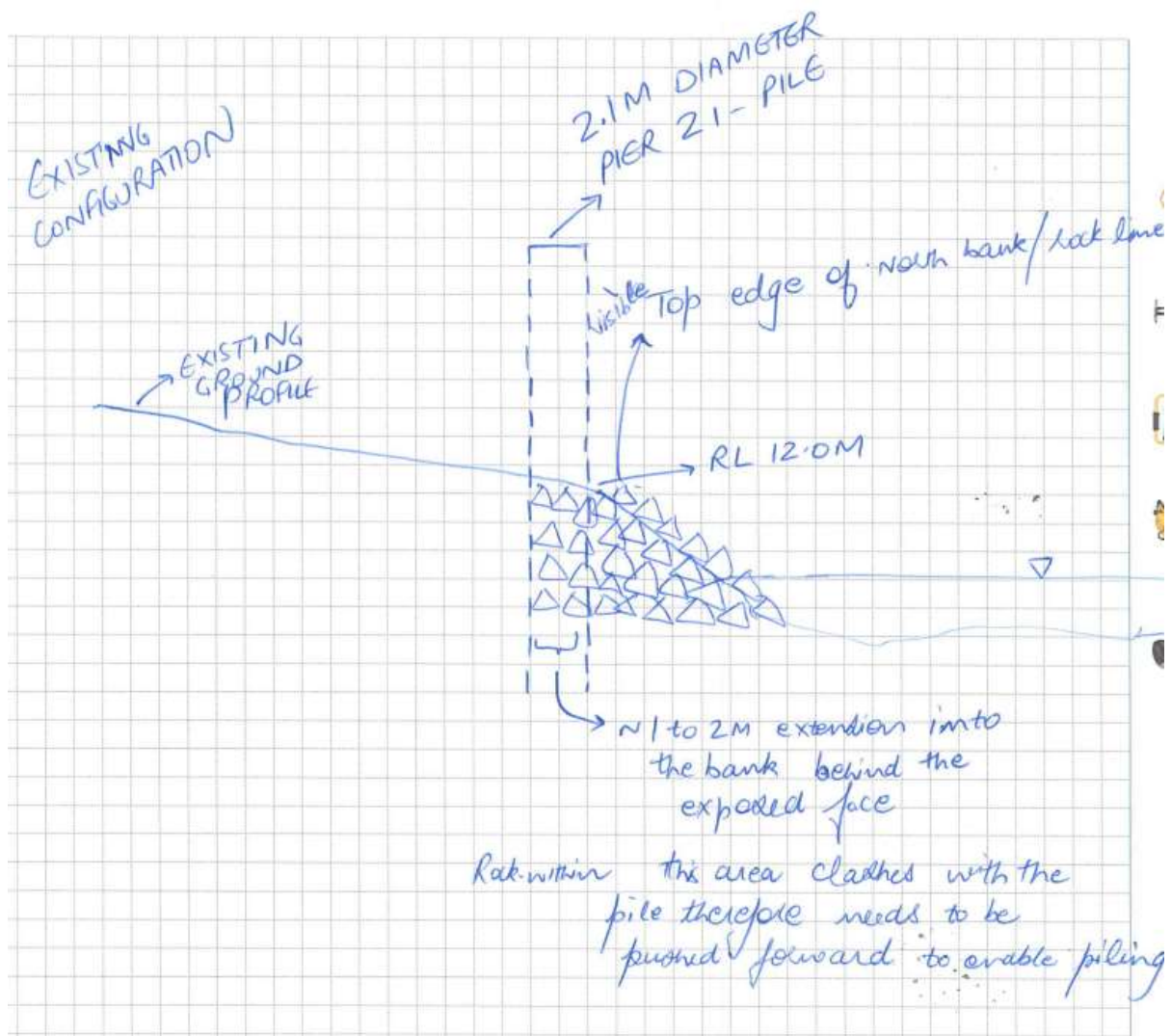

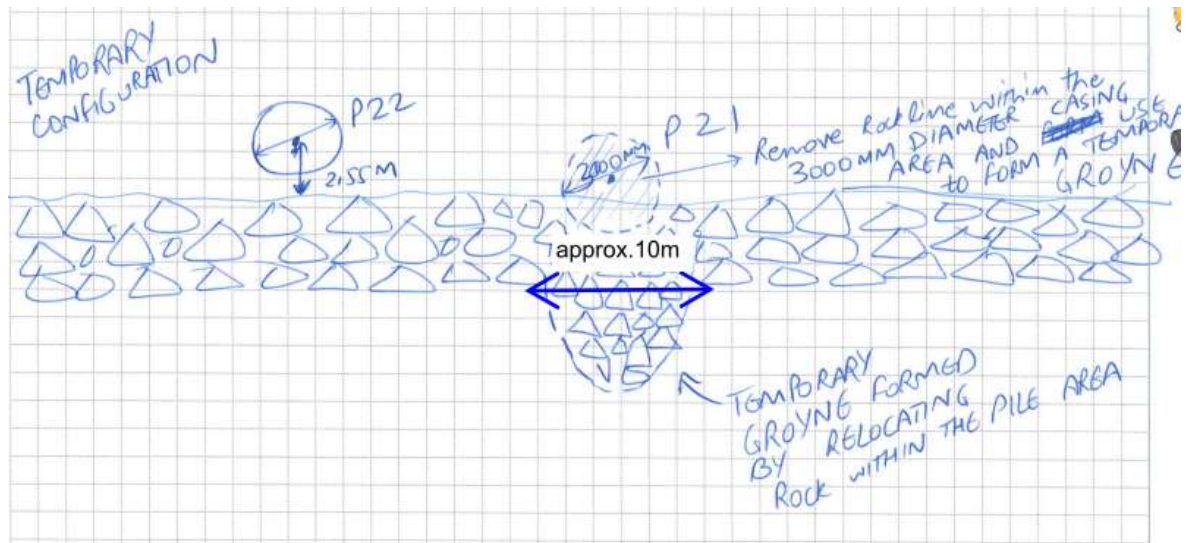
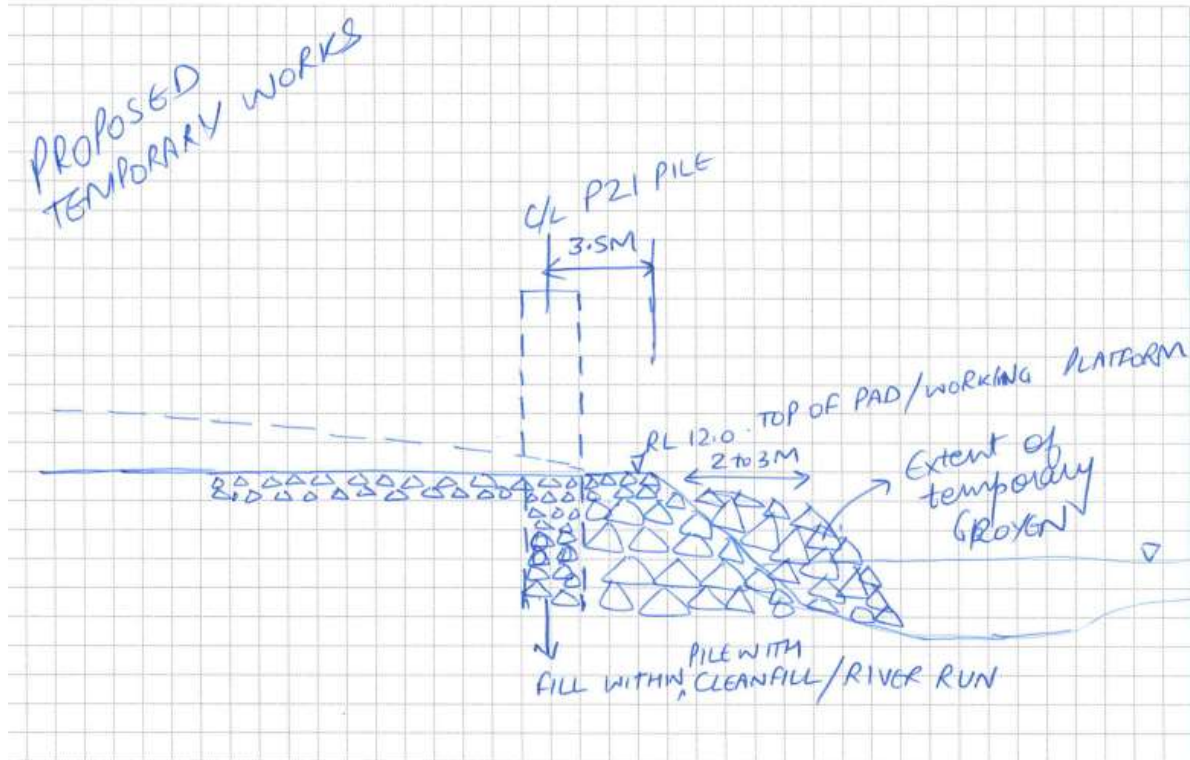

Figure 2: Proposed changes to Ōtaki River rock wall

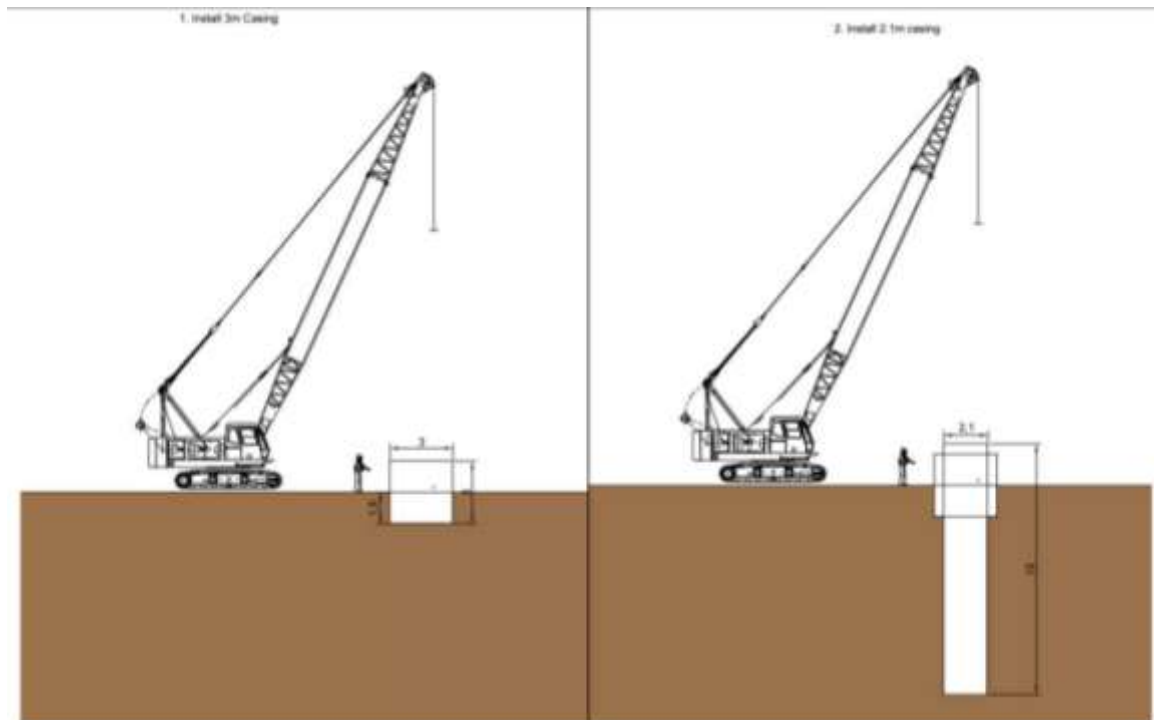

Figure 3: Casing install sketch

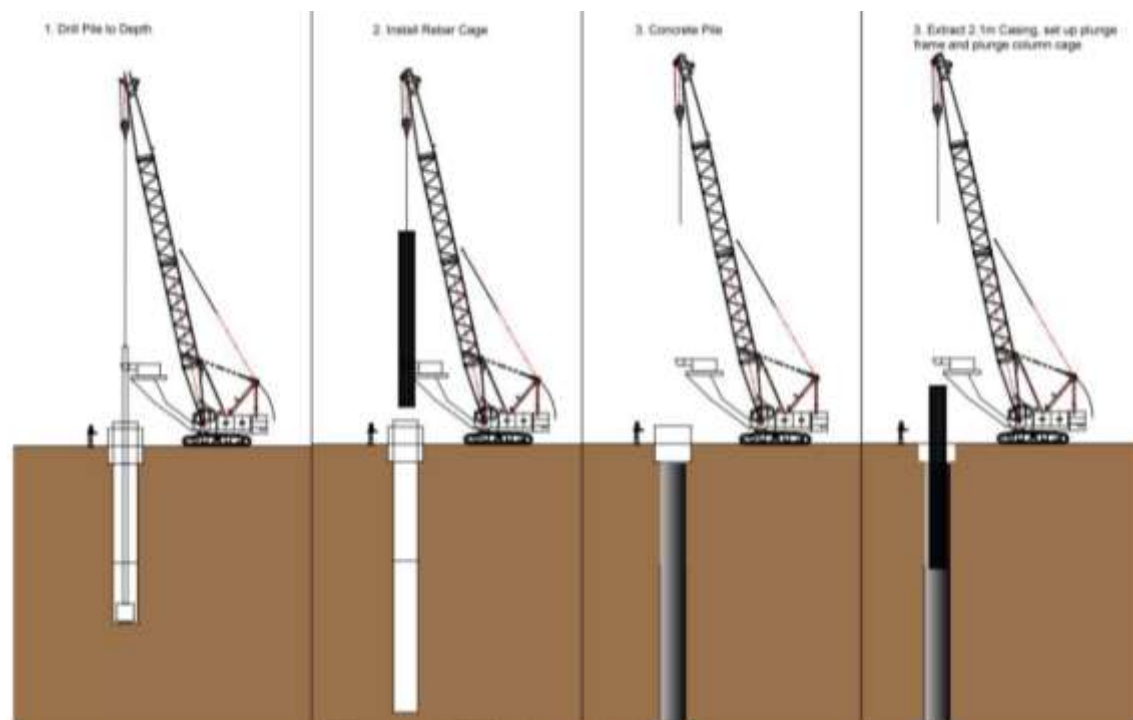

Figure 4: Pile installation sequence

## 3.5 Substructure

The bridge piers consist of reinforced concrete tapered crossheads with up-stands, each supported by two 1600mm diameter columns.

### 3.5.1 Column Construction

- Install formwork with bracing
- Pour concrete
- Cure
- Strip

### 3.5.2 Crossheads

- Install falsework corbel
- Fit out falsework
- Install falsework
- Form soffit
- Install pre-fabricated reinforcing cage
- Form stage 1 (Bottom shelf)
- Pour stage 1
- Cure stage 1
- Strip stage and associated falsework 1
- Form stage 2
- Pour stage 2
- Cure stage 2
- Strip stage 2
- Patch
- Repeat above for remainder of crossheads

## 3.6 Superstructure and Ancillary

The following activities are relevant for both the north and south side of the river:

### 3.6.1 Construct abutment beams

- Erect abutment beam edge protection
- Prep and Pour blinding
- **Note:** The blinding shall be chute placed from the adjoining access tracks formed as part of the preload and approach construction.
- Fix reinforcing
- Form
- Pour
- Cure
- Strip
- Prep abutment beam for bearing and beam placement

### 3.6.2 Beams and Bearing Placement

It is noted that the beams and bearing placement will generally be from the Northern end of the bridge, however, as sequencing permits these will be placed on the Southern approach.

- Construct crane construction pads.
- Mobilise the crane to site and into position.
- Deliver the first beam to site.
- Dress the first beam with walkways and any other required items such as bridge services
- Install and deliver the remainder of the beams that the sequencing permits, the remainder will be placed from the northern embankment.

### 3.6.3 Deck Construction

- Seal deck using timber, ply and sealant for boats and between the flanges of the tees.
- Erect deck edge form and stop ends ready for reinforcing.
- Fix reinforcing to height
- Establish screed rails
- Setup pump and associated secondary environmental and/or hazard controls where required, such as polythene over streams or catch nets over walkways. The deck edge form will be set higher to ensure that potential runoff is directed to land (particularly relevant for the span between Pier's 2 and 3 over water).
- Place and finish concrete
- Setup curing system which will consist of hessian and black plastic with a water feed on trickle.
- Remove curing system and dispose of accordingly
- Remove walkways off beams and install temporary edge protection ready for installation of the precast barriers.
- Form, reinforce and pour expansion joint

### 3.6.4 Construction of Settlement Slab and Placement of Abutment Backfill

- Complete backfill of abutment upto the underside of the settlement slab.
- Form, reinforce and pour the Settlement slab
- Setup curing system which will consist of hessian and black plastic with a water feed on trickle.
- Remove curing system and dispose of accordingly
- Backfill to required level

### 3.6.5 Barrier Construction

- Establish crane for installation of precast barriers.
- Deliver precast units to site and install.
- Pour insitu stitch at barrier base.
- Install and grout rail atop of precast barrier.



## 3.7 Final Earthworks

- Permanent access routes between east and west (public access and over dimension route)
- Rock armouring

# 4 ENVIRONMENTAL MANAGEMENT

The following section identifies key environmental aspects that need to be considered prior to and during construction activities covered under this SSEMP.

## 4.1 General Pre-works Requirements

As part of the site preparation and establishment works the following mitigation measures will be implemented to avoid or minimise adverse environmental effects:

- Sensitive areas in regards to ecology, archaeology, and residential / commercial receivers in close proximity to works will be clearly marked on drawings (attached) and provided to the relevant contractor(s) prior to commencement of works.
- Site specific information, including environmental constraints and requirements, will be discussed at the relevant pre-construction site meetings with input from specialists as required.
- Prior to works commencing in this area, the project surveyors will use GPS to identify the extent of works. The works area will be clearly marked-out with regular input from the survey team throughout works as required.
- Areas identified as 'retained vegetation' as per the approved vegetation retention plans will be clearly delineated using physical markers on site.
- Environmental requirements for any given area will be noted on each project 'Permit to Work'. These permits are required for any activity on site and must be in place and signed off by the environmental team prior to works commencement.

## 4.2 Erosion and Sediment Control

- Gravel diversion bunds approximately 500mm high (RL 12m) will be established along the southern extent of the works to protect the river from potential site runoff while still allowing the area to be inundated in larger flood events.
- Dirty water diversion bunds >500mm will also be installed around the stockpile located between the access diversion and preload embankment.
- The working platform will be constructed from gravel material and set at RL 11.5m. Additional erosion protection is not proposed. The platform will be maintained in a tidy state with non-gravel materials carted to the allocated stockpiles away from the river on a daily basis.
- Any minor ground disturbance outside of the footprint of the gravel platform will be stabilised using wood mulch.

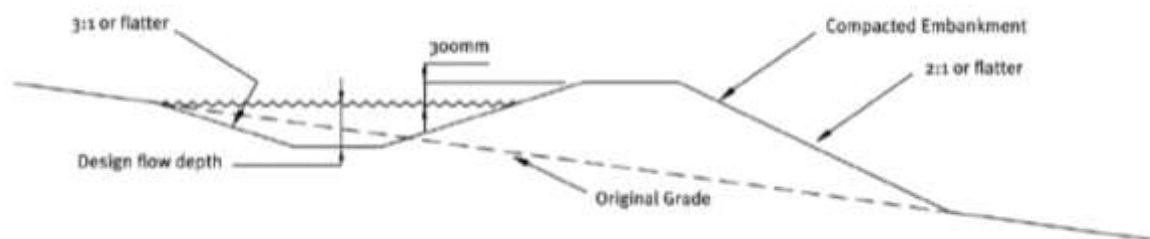

Figure 5: Typical cross section of dirty water diversion bund in accordance with the project ESCP.

## 4.3 Bentonite and Concrete Management

### 4.3.1 Bored Piling

- During piling, an oversized 3m diameter casing will be installed over the 2.1m diameter casing to ensure that any over-spill is captured within the outer casing.
- The top of the 2.1m diameter casing will extend to >RL +13.0m (approximately 10% AEP flood event).
- Bentonite will be maintained >1.5m above groundwater level.
- Drill cuttings will be transferred from the bore location and disposed of to a lined skip bin or suitable alternative to be disposed of to stockpile away from the river on a daily basis.
- During piling, as concrete comes up, bentonite will be disposed of back to the bentonite plant.
- Polythene sheets will be used around the outer casing if deemed necessary following the first concrete pour (contingency only).
- Any contaminated over-spill into the outer casing will be disposed of via sucker truck directly offsite to an approved facility.
- Bentonite tanks will be set up on higher ground in the location of the existing river access track.
- River booms will be available on site at all times during the works as a contingency in the event of a spill.
- River levels and rain warnings will be monitored to ensure that adequate flood response procedures are followed and plant and equipment is removed to safe levels promptly. Refer to Section 5 for further details.

### 4.3.2 Deck Construction

Concrete pours during deck construction will need to be managed carefully to ensure that water is channelled to an allocated area during pouring and curing, particularly between Pier's 2 to 4 which will be poured over live water.

Deck edge form will be erected higher than the deck to ensure that potential runoff is directed to the north or south of the river to land and contained within site controls.

As a precautionary measure, polythene or similar may also be utilised during curing to catch concrete runoff.

## 4.4 Ecological Requirements

Appendix C outlines areas which require ecological input prior to and / or during construction activities. The following sections outline site specific ecological requirements relating to works due to be carried out under this SSEMP.

### 4.4.1 Banded Dotterels

Condition G.46A requires:

*“Prior to the breeding season before the commencement of construction of the Ōtaki River Bridge, the consent holder shall prepare suitable habitat for Banded Dotterel nesting upstream of the Ōtaki River Bridge in a location to be agreed with the Manager. The consent holder shall remove woody weeds from the nesting area prior to the breeding season and control woody weeds during construction of the Ōtaki River Bridge. Details of the location, area and maintenance regime for the proposed area of nesting habitat shall be included in the EMP.”*

The EMP is currently being updated and will include details of proposed measures to satisfy Condition G.46A. In summary:

- Banded Dotterels are known to preferentially nest in open areas of bare alluvium on lowland rivers, and the distance to features which may offer cover for predators influences the choice of nest site location.
- Extensive bare alluvial gravel beaches exist upstream of the Ōtaki River Bridge. Woody weeds (especially lupins) can be found in patches along both banks, and in places these are large enough to offer cover for predators, potentially limiting their suitability as Banded Dotterel nesting habitat.
- To satisfy Condition G.46A it is proposed that a woody weed control programme is implemented for the duration of the Ōtaki River Bridge construction. Details include:
  - Location: Upstream of the Ōtaki River Bridge and potential gravel recovery areas associated with the southern side piling works. The specific location is still to be confirmed and will depend on access availability.
  - Area: Specific area to be confirmed but likely to be between 2 – 2.5ha.
  - Maintenance regime: Initial weed control will involve manual removal of all woody weeds. During the Banded Dotterel breeding season (July-January) monthly weed checks will be made over the entire area and where deemed necessary, further manual weed removal will be made. Where woody weeds are too large for manual removal, the stem will be cut near to ground level and herbicide gel applied. No herbicide sprays will be used to control weeds at any stage.

## 4.5 Water Quality Monitoring

Triggered turbidity monitoring within the Ōtaki River will occur in accordance with the PP20 Updated Turbidity Monitoring Proposal dated 12 April 2018. In summary, triggered NTU monitoring will be carried out in accordance with Section 6.3 of the project Erosion and Sediment Control Plan (ESCP),

however revised rainfall triggers have been adopted for this site to align with required flood response within the flood plain.

In the event that any of the flood alert levels 1 – 4 outlined in Section 5 below are exceeded, NTU monitoring is required upstream and downstream of the works 24 and 48 hours post-rain event. Procedures outlined within Section 6.3 of the ESCP will be followed in the event of any exceedances. NYU monitoring locations have been identified in Appendix C layout drawings.

## 4.6 Cultural Monitoring

A Kaiarahi (iwi guide / leader) is the key point of contact and coordination for Ngā Hapū o Ōtāki. The Kaiarahi will be involved in the design process, construction supervision and environmental monitoring. The Kaiarahi will be supported by Pūkenga (specialists / experts) and Kaitiaki (guardians) who provide support in supervision, monitoring activities and provision of specialist advice in regards to cultural monitoring. Ngā Hapū o Ōtāki will be informed of all works on site and invited to be present for all works with particular emphasis placed on initial topsoil stripping and streamworks.

Contact must also be maintained with Muaupoko Tribal Authority (MTA) in accordance with MTA agreement and confirmed accidental discovery protocols.

## 4.7 Archaeology

All works under this SSEMP will be carried out in accordance with the approved archaeological authority and the Archaeological Site Management Plan. The Archaeological Site Management Plan outlines high, medium, and low probability archaeological areas across the project footprint.

Two areas of the site that fall within the scope of works are identified as 'high probability' in the Archaeological Management Plan (the original 'Clifden Cottage site' to the south and 'Kaingaraki Pa' to the north) and therefore pre-works investigations were undertaken in these areas.

Although already largely disturbed, the following will take place as a minimum unless otherwise specified by the project Archaeologist:

- Site visits will take place by kaitiaki and the project Archaeologist to monitor all excavation.
- Discovery protocols will be adhered to in all areas.



Figure 6: The Clifden Cottage property (outlined in yellow)



Figure 7: The Kaingaraki Pa site outlined in yellow

## 4.8 Noise and Vibration

The Construction Noise and Vibration Management Plan (CNVMP) identifies the noise and vibration performance standards that must, where practicable, be complied with. It also sets out best practicable options for noise and vibration management for the Project, including mitigation measures, monitoring requirements, and communication and complaint procedures. All works under this SSEMP will be carried out in general accordance with the CNVMP.

High-risk areas in regards to potential noise and vibration effects as a result of works have been identified in Appendix C. Individual dwellings located within the high risk areas have also been listed below.

In accordance with the CNVMP, works carried out under this SSEMP will generally be restricted to take place between the hours of:

- 0630 and 2000hrs on weekdays; and
- 0730 and 1800hrs on Saturdays.

As far as practicable, works will be scheduled to avoid noisy activities in areas identified as sensitive receivers on the attached drawings between 0630 – 0730hrs in the morning, and between 1800 – 2000hrs in the evening to align with noise level criteria outlined in the CNVMP.

It is not anticipated that works will be required to take place outside of normal working hours for works outlined in this SSEMP. In the event that this changes, the procedures outlined in the CNVMP will be followed. Any works outside of the hours of 7am to 7pm require written approval from the Project Engineer.

The primary mitigation measure in regards to reducing the impacts from construction noise and vibration will be ongoing effective community consultation, particularly when transitioning from one works phase to another.

Noise and vibration monitoring will take place throughout the works to assess the impacts on adjacent properties at various locations. In the event that noise or vibration criteria is exceeded, mitigation options will be reassessed in an effort to comply with the construction limits, and a site specific noise 'schedule' will be submitted to Kapiti Coast District Council in accordance with the CNVMP.

Dwellings located within the noise and vibration boundary are as follows:

- 45 Ōtaki Gorge Road

Dwellings within the vibration boundary only are as follows:

- 1277 SH1

#### 4.8.1 Pre-condition building surveys

Section 7 of the CNVMP outlines activities that are expected to generate vibration that will potentially cause medium and high level vibration and therefore must be assessed to determine whether a pre-condition building survey is required. There are no dwellings that trigger the requirement for a pre-condition building survey prior to these works.

## 4.9 Air Quality

Although not anticipated given the nature of the material and location of works, there is potential for works to generate dust discharge if the site is not managed effectively. The Construction Air Quality Management Plan (CAQMP) outlines methods to be used to prevent dust and odour nuisance during

construction from the site. All works under this SSEMP will be carried out in general accordance with the CAQMP.

To ensure that dust does not become an issue across the boundary of the site, the following measures will be implemented as a minimum:

- Use of water carts as required
- Imposing a speed limit if required
- Use of stabilising agents such as polymers if required (not anticipated given the location of works and gravel fill material but may be utilised on stockpiled topsoil / unsuitables).
- Assessing wind speed and direction on a daily basis and implementing additional mitigation based on conditions (or ceasing / re-programming works if required).

To the south of the river, one property at 45 Ōtaki Gorge Road is approximately 300m from the works and falls within the 'high risk air quality' zone as identified in Appendix C 'Environmental Constraints' drawings. Provided that the site is managed effectively, it is not anticipated that these works will cause any adverse impacts.

## 5 STORMWATER / FLOOD MANAGEMENT

*Note: for completeness and ease of interpretation, the following information applies to both the south and north side works and aligns with information outlined in SSEMP BR5A 'Bridge 5 – Stage One'.*

Rainfall frequency is based on Waitatapia Stream at Taungata – GWRC Flood Procedures Manual, and levels are based on NZVD (2009). Rainfall vs actual inundation of this area will continue to be assessed throughout the works.

The following information should be read in conjunction with the Bridge 5 Flood Management Plan FCCL-BG-WPLN-005 attached as Appendix F. The Flood Management Plan outlines criteria for when the project triggers a "Flood Watch Alert" which aligns closely with level 1 flood alert outlined below.

In the event of flood alert levels 1, 2, 3, or 4, the following actions and associated environmental monitoring will take place.

### Alert Level 1

#### Expected inundation:

- Inundation of working platforms (Pier's 3-7)

| Return Period (Years) | Average Annual Probability (%) | Water level (RL m) | Flow at Pukehinau gauge <sup>1</sup> (m <sup>3</sup> /s) | Rainfall Depth at Taungata gauge <sup>3</sup> (cumulative mm) for Selected Duration (Hours) |      |      |      |       |       |
|-----------------------|--------------------------------|--------------------|--|---|------|------|------|-------|-------|
|                       |                                |                    |  | 1hr   | 2hrs | 3hrs | 6hrs | 12hrs | 24hrs |
| <1                    |                                |                    | 431  | 8   | 12   | 15   | 25   | 40    | 60    |

Note<sup>1</sup>: Flow based on Ōtaki River at Pukehinau – GWRC Flood Procedures Manual

**Alert level sequence:**

- Automated GWRC Alarm 1 at Pukehinau (triggered at 431m<sup>3</sup>/s) received via phone indicating that platforms are at risk of inundation.
- Based on historical information, there is approximately a 2-4 hour window from rain falling at the gauge until inundation of the work site.

**Associated actions / monitoring:**

- Visual inspection of site focussing specifically on erosion and sediment controls and containment of dirty water.
- Handheld NTU sampling upstream and downstream of the site in accordance with ESCP section 6.3.3 (24 and 48 hours post event).
- Low level risk of flood inundation unless works are taking place at the piling locations – initial warning to be issued to site team to indicate level one alert.
- The site will be tidied as far as practicable (i.e. removal of loose items such as spill kits, skip bins, pumps and hoses).
- Loose material will be removed to prevent material from re-suspending as far as practicable.

**Alert level 2****Expected inundation:**

- Northern side platform (Pier's 1 & 2)
- Southern side bentonite area (encapsulated by diversion bunds)

| Return Period (Years) | Average Annual Probability (%) | Water level at site <sup>1</sup> (RL m NZVD 2009) | Flow at Pukehinau gauge <sup>2</sup> (m <sup>3</sup> /s) | Rainfall Depth at Taungata gauge <sup>3</sup> (cumulative mm) for Selected Duration (Hours) |      |      |      |       |       |
|-----------------------|--------------------------------|---|--|---|------|------|------|-------|-------|
|                       |                                |   |  | 1hr   | 2hrs | 3hrs | 6hrs | 12hrs | 24hrs |
| 2                     | 50                             | 12.5  | 900  | 24mm  | 37mm | 48mm | 76mm | 114mm | 145mm |

Note<sup>1</sup>: Based on the mean annual flood level upstream of the rail bridge reported in section 18.9.6 of the Specimen Design Report (Opus September 2015)

Note<sup>2</sup>: Flow based on Ōtaki River at Pukehinau gauge – GWRC Flood Procedures Manual, also consistent with updated flood frequency analysis for PP2Ō.

Note<sup>3</sup>: Rainfall frequency information based on Waitatapia Stream at Taungata – GWRC Flood Procedures Manual.

**Alert level sequence:**

- Automated GWRC Alarm 2 at Pukehinau (triggered at 555m<sup>3</sup>/s) received via phone indicating that the bentonite area is at risk of inundation.



- Based on historical information, there is approximately a 2-4 hour window from rain falling at the gauge until inundation of this area.

#### Associated actions / monitoring:

- South of the river – the site team will remove any mobile plant and equipment from the river bed and relocate to either the southern embankment (depending on works progress), or up to Bridge Lodge.
- North of the river – the site team will remove any mobile plant and equipment from the platform and relocate to either the northern embankment or further north to higher ground.
- Loose material will be removed (i.e. drill cuttings) or compacted (gravels) to prevent material from re-suspending as far as practicable.
- The site will be tidied as far as practicable (i.e. removal of loose items such as spill kits, skip bins, pumps and hoses).
- Handheld NTU sampling upstream and downstream of the site in accordance with ESCP section 6.3.3 (24 and 48 hours post event).

### Alert level 3

#### Expected inundation:

- Southern side stockpile location

| Return Period (Years) | Average Annual Probability (%) | Water level at site <sup>1</sup> (RL m NZVD 2009) | Flow at Pukehinau gauge <sup>2</sup> (m <sup>3</sup> /s) | Rainfall Depth at Taungata gauge <sup>3</sup> (cumulative mm) for Selected Duration (Hours) |      |      |       |       |       |
|-----------------------|--------------------------------|---|--|---|------|------|-------|-------|-------|
|                       |                                |   |  | 1hr   | 2hrs | 3hrs | 6hrs  | 12hrs | 24hrs |
| 20                    | 5                              | 14.3  | 1370   | 39mm  | 57mm | 71mm | 116mm | 161mm | 249mm |

Note<sup>1</sup>: Based on the mean annual flood level upstream of the rail bridge reported in section 18.9.6 of the Specimen Design Report (Opus September 2015)

Note<sup>2</sup>: Flow based on Ōtaki River at Pukehinau gauge – GWRC Flood Procedures Manual, also consistent with updated flood frequency analysis for PP2Ō.

Note<sup>3</sup>: Rainfall frequency information based on Waitatapia Stream at Taungata – GWRC Flood Procedures Manual.

#### Alert level sequence:

- Switch from automated GWRC alert to PP2Ō active monitoring (environmental team) of Metservice rain radar, rainfall at Taungata gauge and discharge at Ōtaki River at Pukehinau gauge using GWRC's live data viewer, supported by observations of rainfall and river levels on site.

- Based on historical information, there is approximately a 4 – 4 ½ hour window from rain falling at the gauge until inundation of this area.

#### Associated actions / monitoring:

- Level 2 alert levels should have already initiated flood response.
- The site team will remove any mobile plant and equipment from the river bed and relocate to either the southern embankment (depending on works progress), or up to Bridge Lodge which is several metres above the 100 year return period flood level.
- Plant and machinery located within the stockpile area will be relocated to the areas mentioned above.
- Loose stockpile material will be compacted / shaped if safe to do so. Note that if this level of event is predicted then safety will be the first priority for personnel working within the flood plain. All measures to tidy the site will be carried out in advance during level 2 alert response.
- Handheld NTU sampling upstream and downstream of the site in accordance with ESCP section 6.3.3 (24 and 48 hours post event).

#### Alert level 4 - 100 year return period expected

If the 100 year return period flood level below is reached then inundations of the entire site is likely.

| Return Period (Years) | Average Annual Probability (%) | Water level at site <sup>1</sup> (RL m NZVD 2009) | Flow at Pukehinau gauge <sup>2</sup> (m <sup>3</sup> /s) | Rainfall Depth at Taungata gauge <sup>3</sup> (cumulative mm) for Selected Duration (Hours) |      |      |       |       |       |
|-----------------------|--------------------------------|---|--|---|------|------|-------|-------|-------|
|                       |                                |   |  | 1hr   | 2hrs | 3hrs | 6hrs  | 12hrs | 24hrs |
| 100                   | 1                              | 14.85   | 1690   | 53mm  | 71mm | 83mm | 135mm | 181mm | 314mm |

Note<sup>1</sup>: Based on the mean annual flood level upstream of the rail bridge reported in section 18.9.6 of the Specimen Design Report (Opus September 2015)

Note<sup>2</sup>: Flow based on Ōtaki River at Pukehinau gauge – GWRC Flood Procedures Manual, also consistent with updated flood frequency analysis for PP2Ō.

Note<sup>3</sup>: Rainfall frequency information based on Waitatapia Stream at Taungata – GWRC Flood Procedures Manual.

#### Alert level sequence:

- Same approach to be applied as 'Alert Level 3'. PP2Ō active monitoring (environmental team) of MetService rain radar, rainfall at Taungata gauge and discharge at Ōtaki River at Pukehinau gauge using GWRC's live data viewer, supported by observations of rainfall and river levels on site.
- Based on historical information, there is approximately a 4 – 4 ½ hour window from rain falling at the gauge until inundation of this area (20 year event response applied here given the severity of the event).

**Associated monitoring / actions:**

- Plant and machinery will be evacuated to Bridge Lodge on the south side or north of the flood bund on the north.
- Measures should have been implemented as per level 2 and 3 alert level responses.
- Priority will be given to ensuring safety of site personnel and the public in the general Ōtaki area.

In the event that any project plant or materials are swept downstream during a flood event, it will be the responsibility of the PP2Ō project to repair any damage and clean-up / remove any plant or materials downstream of the site in a timely manner.

## 6 TRAFFIC AND PUBLIC SAFETY

There are no additional site access / egress points required for works covered under this SSEMP. The existing access / egress point into the Bridge Lodge Compound area (SAP 10) will be utilised for deliveries and vehicle access from the south. All heavy machinery will be transported to site as one-off deliveries and will not require temporary traffic management.

For works on the northern side of the river, construction traffic will be managed carefully to ensure that the existing operations are not impacted by the project works. A Site Specific Traffic Management Plan has been prepared for these works and attached as Appendix E. Public access to any of the works covered by this SSEMP will not be permitted. Fencing and signage will be erected prior to works to alert the public not to enter any live work sites.

Immediate neighbours and the general public will be notified of each stage of works in accordance with requirements set out in the Stakeholder and Community Management Plan (SCMP). The Greater Wellington Flood Protection Team, Winstones Aggregates and Stresscrete will be kept up to date with works progress.

## APPENDIX A – SSEMP AUTHORS

| Name             | Role                   | Company               | Input                           |
|------------------|------------------------|-----------------------|---------------------------------|
| Alice Naylor     | Environmental Manager  | Higgins               | All                             |
| Richard Rakovics | Project Civils Manager | Fletcher Construction | Enabling Earthworks Methodology |

|             |                    |                       |  |
|-------------|--------------------|-----------------------|--|
| Harry Singh | Structures Manager | Fletcher Construction | Bridge Works Methodology                 |
| Macu Waga   | Site Engineer      | Fletcher Construction | General sequencing and works methodology |

## APPENDIX B – CONSULTATION RECORD

| Group                   | Date                            |
|-------------------------|---------------------------------|
| Community Liaison Group | Distributed to CLG              |
| GWRC Flood Protection   | SSEMP distribution list Rev A.1 |
| GBC Winstones           | SSEMP distribution list Rev A.1 |

### Outstanding Queries

*The following outlines any queries (relevant to works covered under this SSEMP) that have not been resolved through the SSEMP preparation process, but will instead be closed out via alternative project stakeholder and communication channels:*

NIL

## APPENDIX C – DRAWINGS

Layout Plan

Environmental Constraints Drawing

Construction Drawings

## Layout Plan

# Northern works - Early Stages



Contingency stockpile location already established in accordance with SSEMP WS1

Temporary access diversion

Existing northern preload embankment

Site Access ramps to preload and platform

Working platform for Pier's 1 & 2

Area allocated for bentonite tanks, sign-in sheds and temporary stockpile contained within 500mm diversion bund

Otaki River

Gravel diversion bund 500mm high (note that this may need to be extended to include access ramp)

Upstream NTU monitoring location

Downstream NTU monitoring location



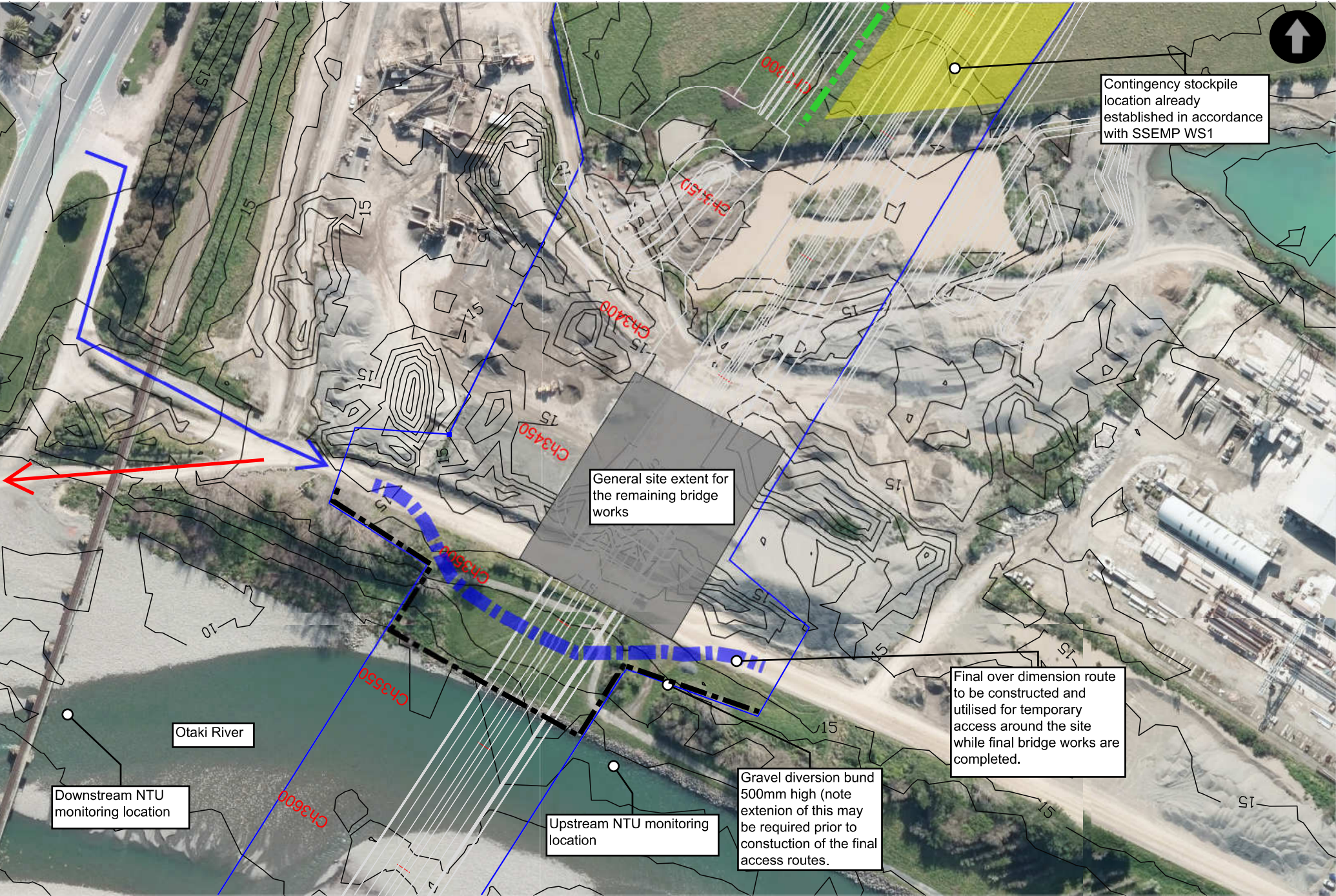

South Side Works (Currently underway)

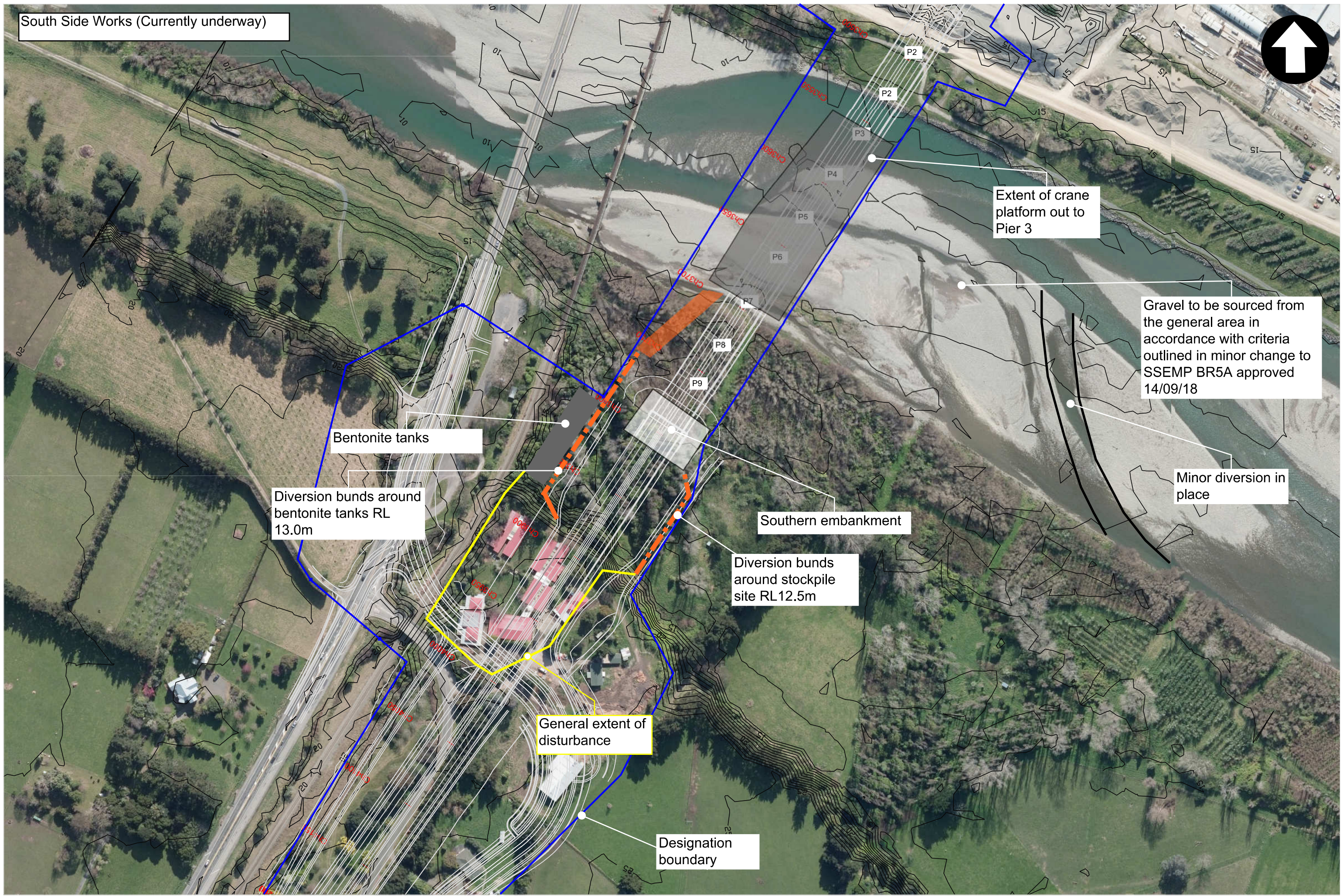

Extent of crane platform out to Pier 3

Gravel to be sourced from the general area in accordance with criteria outlined in minor change to SSEMP BR5A approved 14/09/18

Minor diversion in place

Bentonite tanks

Diversion bunds around bentonite tanks RL 13.0m

Southern embankment

Diversion bunds around stockpile site RL12.5m

General extent of disturbance



Designation boundary

## Environmental Constraints Drawing

**ECOLOGY LEGEND:**

-  TERRESTRIAL ECOLOGY REQUIREMENTS:
-  LIZARD SURVEYS, SALVAGING AND MONITORING
-  NATIVE TREE LOG SALVAGE
-  PERIPATUS MANAGEMENT
-  POWELLIPHANTA TRAVERSI OTAKI SURVEY
-  BIRD SURVEY
-  PIPIT SURVEY
-  BANDED DOTTEREL SURVEY





**NOISE VIBRATION LEGEND:**

-  VIBRATION - LOW RISK (RESIDENTIAL)
-  VIBRATION - LOW RISK (COMMERCIAL)
-  COMMERCIAL STRUCTURES WITHIN VIBRATION BOUNDARY
-  DWELLINGS WITHIN VIBRATION BOUNDARY
-  DWELLINGS WITHIN BOTH NOISE AND VIBRATION BOUNDARIES

**AIR QUALITY:**

-  AIR QUALITY SENSITIVE RECEIVERS



**DRAINAGE LEGEND:**

-  DESIGNATION
-  RAILWAY DESIGNATION
-  EXISTING STREAMS
-  STORMWATER WETLAND/POND

**SITE COMPOUNDS:**

-  HARD STAND AREA
-  SITE ENTRY AND EXIT

**ARCHAEOLOGICAL HIGH-RISK AREAS:**

-  SITE ARCHAEOLOGICAL
-  SITES ARCHAEOLOGICAL-AERIAL-PHOTO

**LANDSCAPE:**

-  EXISTING VEGETATION RETAINED

ORIGINAL IN COLOUR

**FOR INFORMATION  
NOT FOR CONSTRUCTION**

|     |                       |    |     |      |          |
|-----|-----------------------|----|-----|------|----------|
| No. | Revision              | By | Chk | Appd | Date     |
| B   | SSEMP FOR INFORMATION | WW |     |      | 14.09.17 |
| A   | SSEMP FOR INFORMATION | AK | GD  | AN   | 20.07.17 |

|            |   |    |          |                           |
|------------|---|----|----------|---------------------------|
| Scale (A1) | Design                                      | AN | 19.07.17 | Approved For Construction |
| 1:1000     | Drawn                                       | AK | 19.07.17 |                           |
| Scale (A3) | Design Verifier                             |    |          |                           |
|            | Drwg Check                                  |    |          |                           |
|            | * Refer to Original Handcopy for Signatures |    |          |                           |







|          |         |              |                 |
|----------|---------|--------------|-----------------|
| Subject: | ECOLOGY | Discipline:  | CIVIL           |
| Title:   | LEGENDS | Drawing No.: | PP20-DR-CE-0800 |
|          |         | Rev:         | B               |

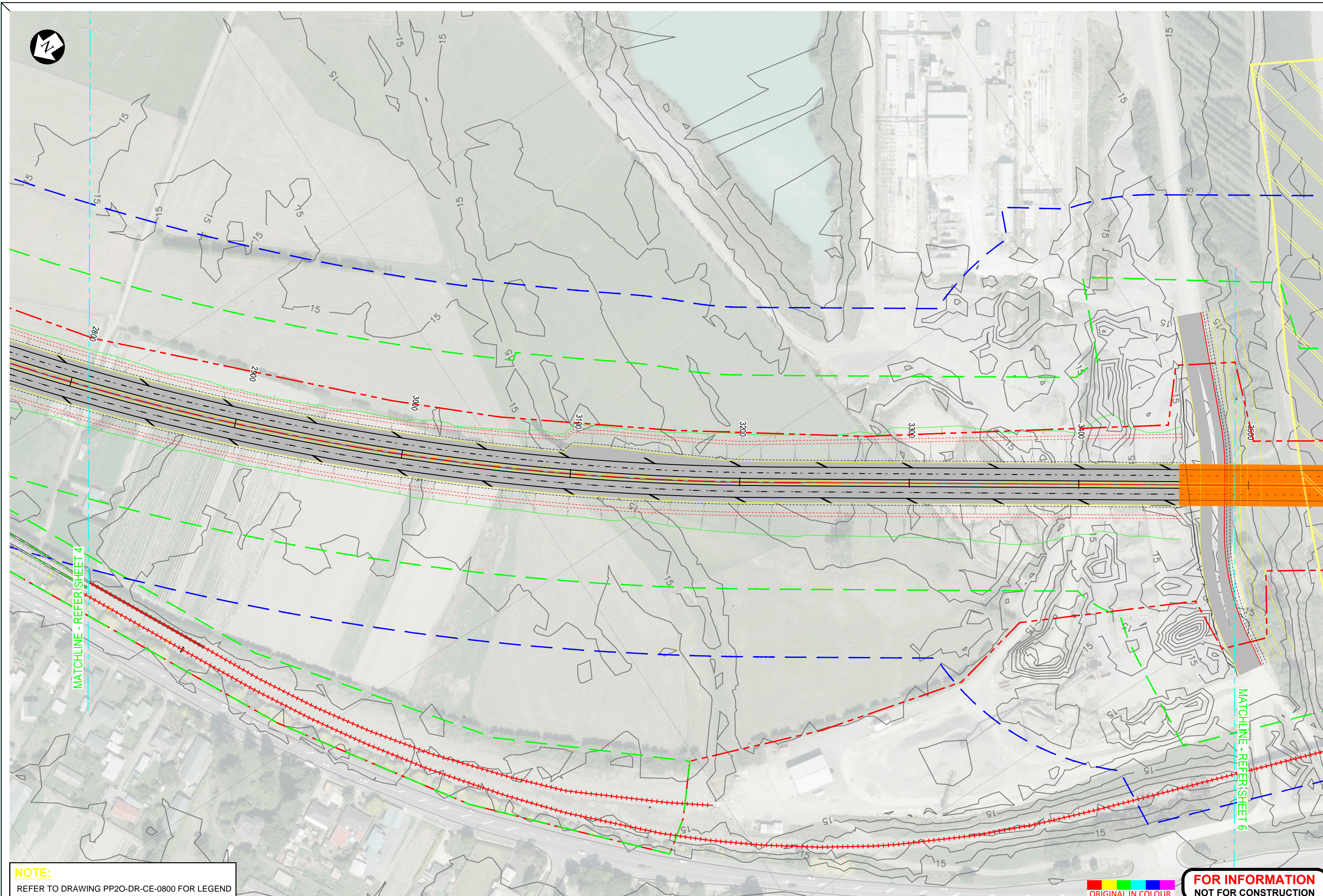

**NOTE:**  
REFER TO DRAWING PP20-DR-CE-0800 FOR LEGEND

ORIGINAL IN COLOUR

**FOR INFORMATION  
NOT FOR CONSTRUCTION**

|     |                       |    |     |      |          |
|-----|-----------------------|----|-----|------|----------|
| No. | Revision              | By | Chk | Appd | Date     |
| B   | SSEMP FOR INFORMATION | WW |     |      | 14.09.17 |
| A   | SSEMP FOR INFORMATION | AK | GD  | AN   | 20.07.17 |

|            |  |    |          |                           |
|------------|--|----|----------|---------------------------|
| Scale (A1) | Design                                     | AN | 13.07.17 | Approved For Construction |
| 1:1000     | Drawn                                      | AK | 13.07.17 |                           |
| Scale (A3) | Dwg Verifier                               |    |          |                           |
|            | Dwg Check                                  |    |          | Date                      |
|            | * Refer to Original Handcopy for Signature |    |          |                           |



**Peka Peka to Ōtaki Expressway**



|          |                              |
|----------|------------------------------|
| Subject: | ECOLOGY                      |
| Title:   | LAYOUT PLAN<br>SHEET 5 OF 18 |

|              |                 |
|--------------|-----------------|
| Discipline:  | CIVIL           |
| Drawing No.: | PP20-DR-CE-0805 |
| Rev:         | B               |

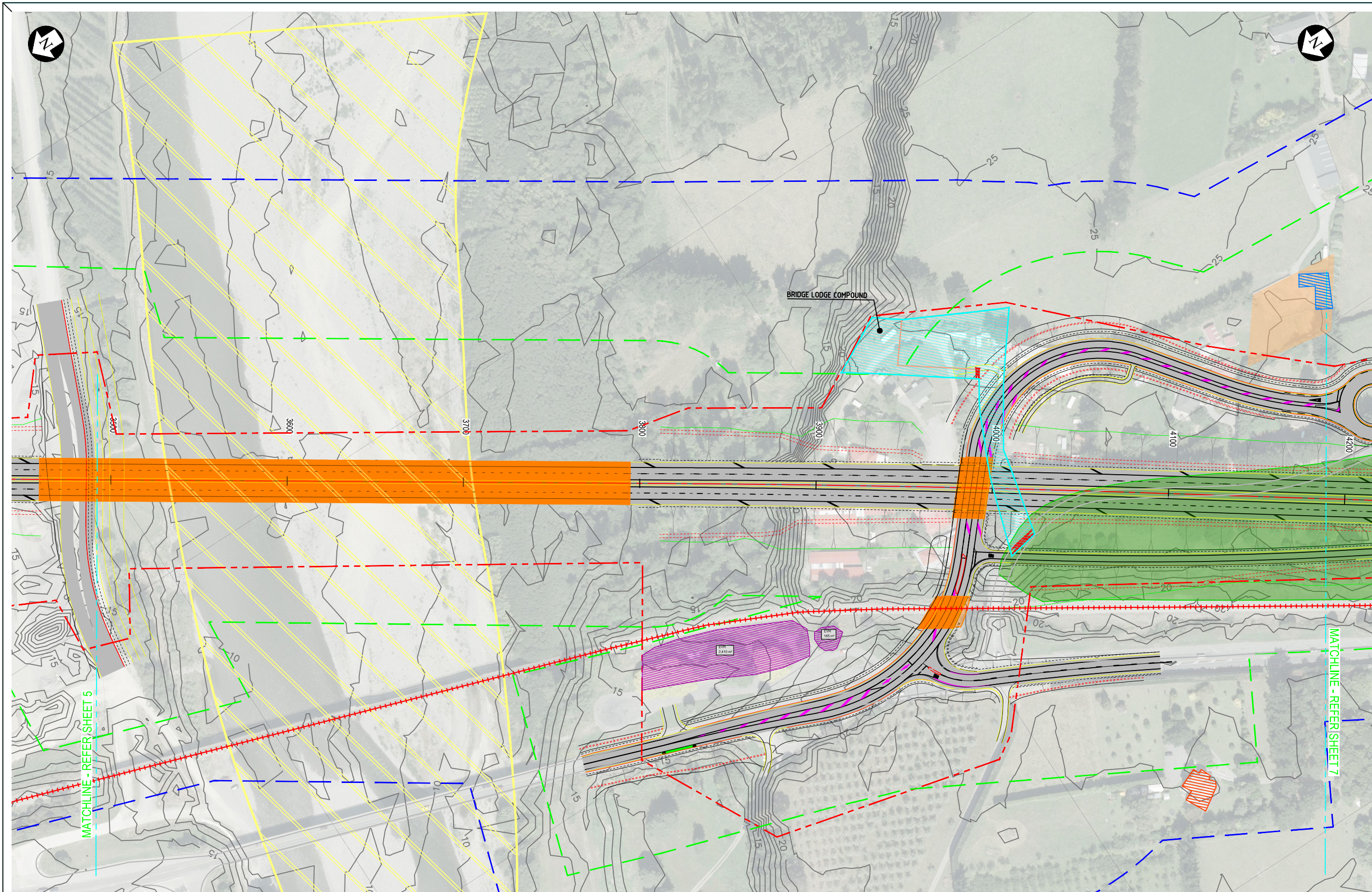

**NOTE:**  
REFER TO DRAWING PP20-DR-CE-0800 FOR LEGEND

**FOR INFORMATION  
NOT FOR CONSTRUCTION**

| No. | Revision              | By | Chk | Appd | Date     |
|-----|-----------------------|----|-----|------|----------|
| B   | SSEMP FOR INFORMATION | AK | GD  | AN   | 14.09.17 |
| A   | SSEMP FOR INFORMATION | AK | GD  | AN   | 20.07.17 |

|                |    |          |                           |
|----------------|----|----------|---------------------------|
| Design         | AN | 13.07.17 | Approved For Construction |
| Drawn          | AK | 13.07.17 |                           |
| Design Checker |    |          |                           |
| Drawn Checker  |    |          |                           |
| Scale (A1)     |    |          |                           |
| Scale (A3)     |    |          |                           |

\* Refer to Original Handcopy for Signature



**Peka Peka to Otaki Expressway**



**HIGGINS**

|          |                              |
|----------|------------------------------|
| Subject: | ECOLOGY                      |
| Title:   | LAYOUT PLAN<br>SHEET 6 OF 18 |

|              |                 |
|--------------|-----------------|
| Discipline:  | CIVIL           |
| Drawing No.: | PP20-DR-CE-0806 |
| Rev:         | B               |

Document No. 1WPPSP-FC-INTERNAL\DA\W\ROOT\2007270 SECTOR GENERAL\PRECAST WORKING SHOP DRAWINGS\PP20-DR-CE-0806-0818 2017-08-28 - STANDARD\PP20-DR-CE-0806-0818\_29-06-SET2.DWG

## Construction Drawings

## 6.6.4 Bridge 5 - Ōtaki River Bridge

### Ōtaki River Bridge Elevation 1:1000

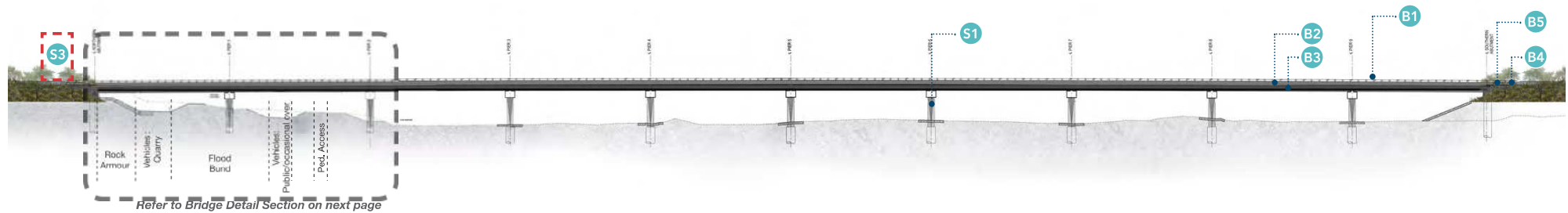

Figure 86. Bridge 5 location - Ōtaki River Bridge

### Ōtaki River Bridge Plan 1:1000

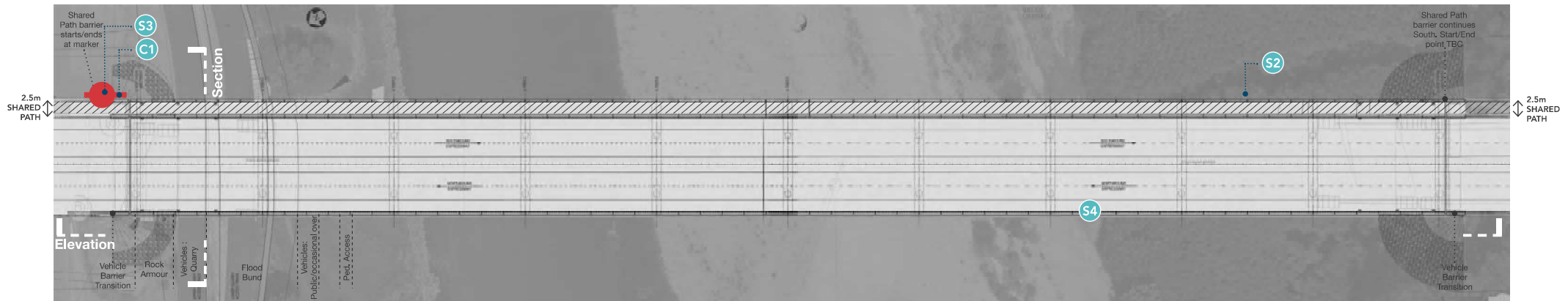

Figure 85. Ōtaki River Bridge Elevation and Plan

Ngā Hapū o Ōtaki regard the bridge as an opportunity to express manaakitanga to people visiting the area. The relationship between iwi, maunga, awa, moana and other local landmarks is integral within Māori value systems. Connectivity to these features engage users in the ever changing state of their environment. It is therefore considered paramount that the visual connection to the river, mountains and sea when driving over the bridge is maintained and enhanced. The slatted steel and lower concrete barriers of the bridge will allow these view shafts to be framed.

» Refer to section 6.3 *Bridge Assemblage* for general objectives key

### Specific Objectives

- S1 Ōtaki River and Waitohu Stream piers to be the same profile, with a triangular face to the outside edge of a circular column, facing away from the bridge. The triangular profile is to have a textured finish. Refer to section 6.6.4.4 for the river bridge pier profile.
- S2 The shared path is to be located on the eastern side of the bridge at 1.4m high, fabricated from metal flat bars in a slatted formation. With a folded creased profile, black finish and integrated lighting it will read similar to M2PP foot bridges. Refer to section 6.6.4.2 for the shared path barrier profile.
- S3 The Ōtaki River is significant to the people. This significance is to be recognised in a vertical marker which is to be integrated at the northern end of the shared path barrier. The markers singular location sits as a transition between concrete and steel barriers of the bridge. Refer to section 6.6.4.3 for the vertical marker profile.
- S4 The crash rail on both sides of the bridge and shared path barrier are to be finished in the same black paint.



### Ōtaki River Bridge Cross Section 1:200

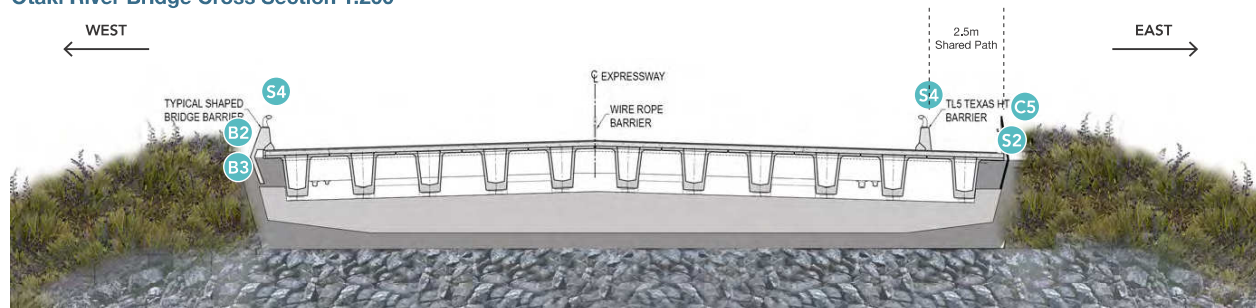

### Material Palette

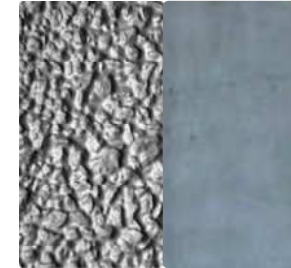

Pier Finish

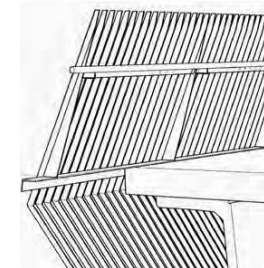

Metal Barrier

### Ōtaki River Bridge Cross Section 1:50

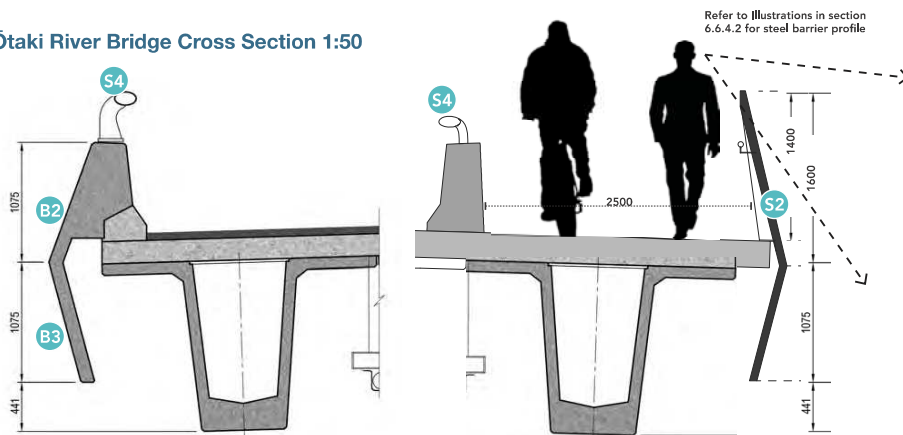

- S1** Textured Form liner finish to triangular face. Off the form standard concrete finish to the remaining structure.



- S2** Metal barrier - profiled metal slatted barrier with lighting to handrail.

### Bridge Barrier

- B2** Simple horizontal element. Finish is off the form concrete with a selected NZTA approved graffiti coating.
- B3** is off the form concrete with a selected NZTA approved graffiti coating.

### Ōtaki River Bridge Detail Section NTS

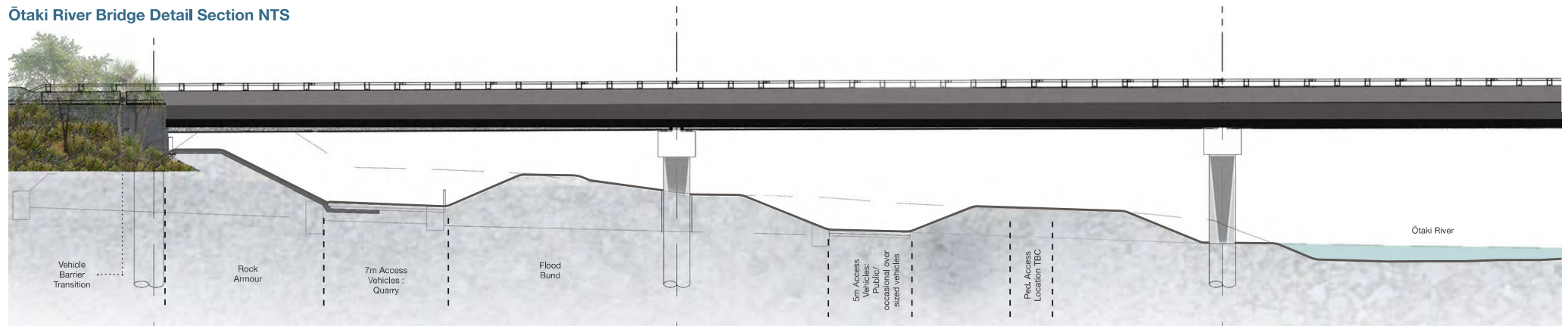

Figure 87. Ōtaki River Bridge Sections

#### 6.6.4.4 Pier Profile

##### Bridge 5 & 1 - Ōtaki River & Waitohu Stream Bridge Pier Profile

The Ōtaki River and Waitohu Stream piers are to be the same profile, with a triangular face to the outside edge of a circular column, facing away from the bridge. This allows the square, horizontal top of the triangle to sit up adjacent to the underside of the square crosshead. The triangular profile is to have a textured finish, achieved with an exposed aggregate form liner.

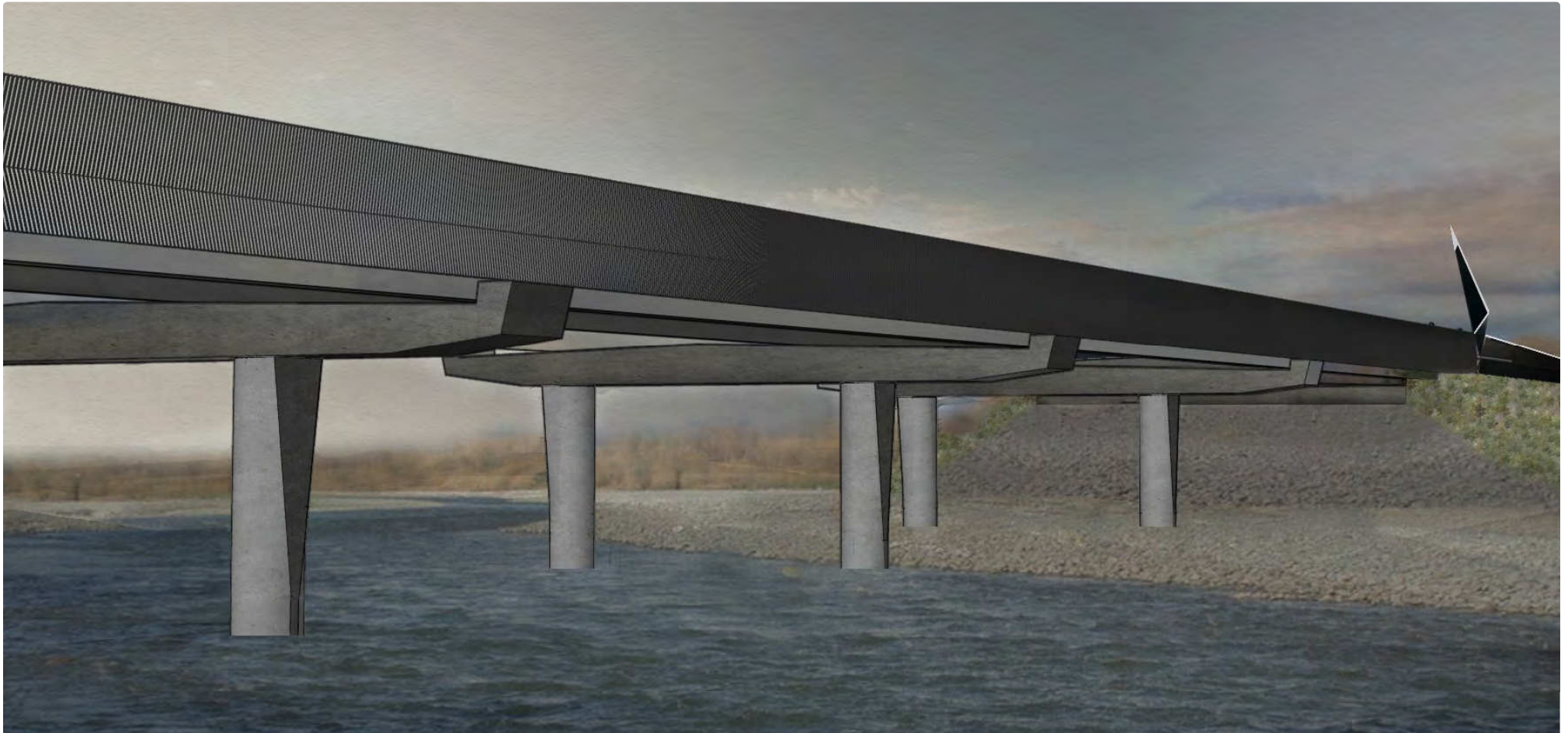

Figure 93. Ōtaki River Bridge piers - Illustrative only (Note: accessways under bridge have not been shown in this image).

Bridge 5 & 1 - Ōtaki River & Waitohu Stream Bridge Pier Profile

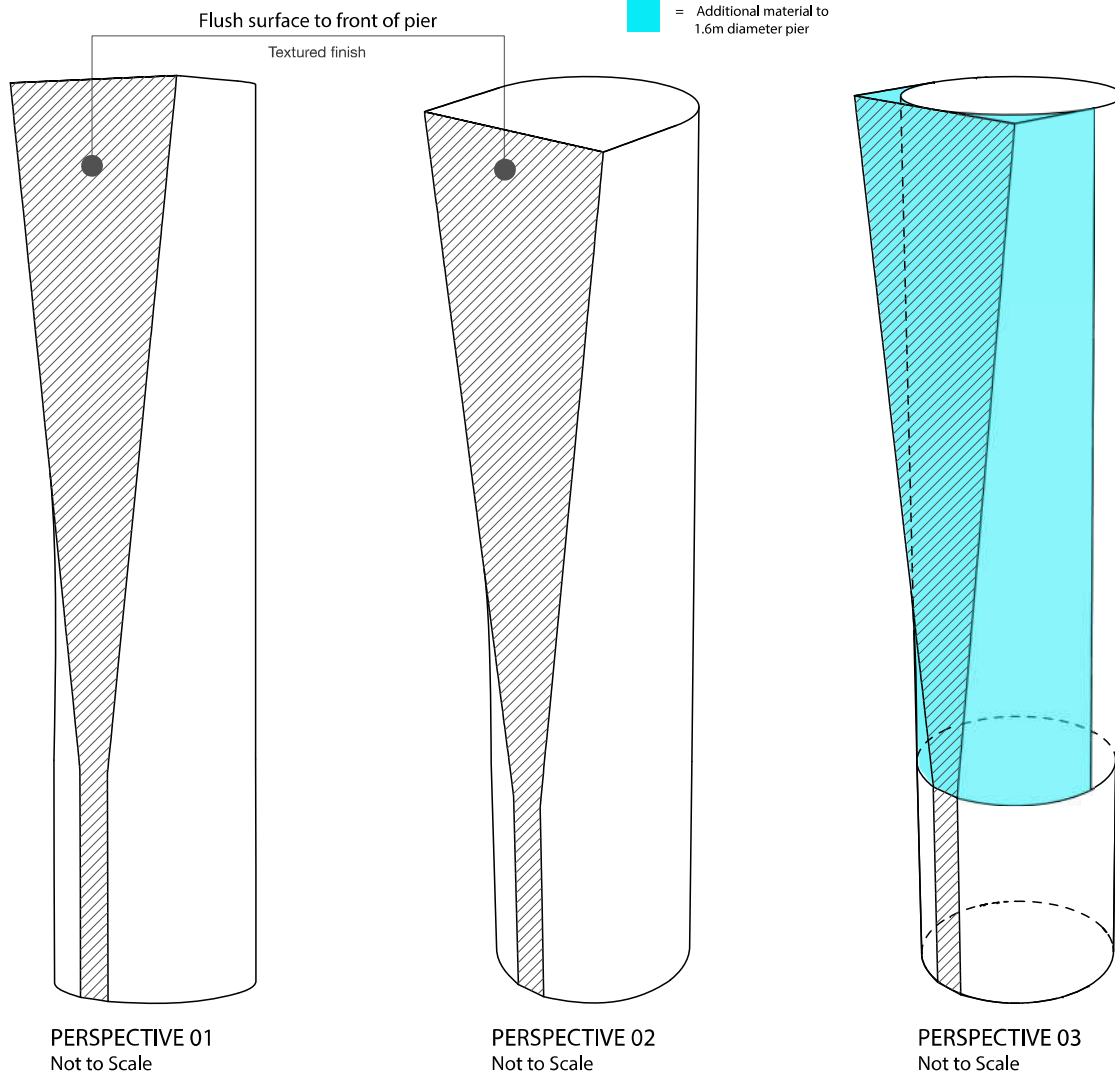
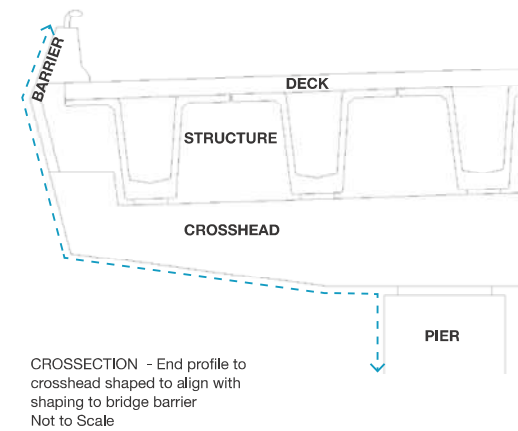
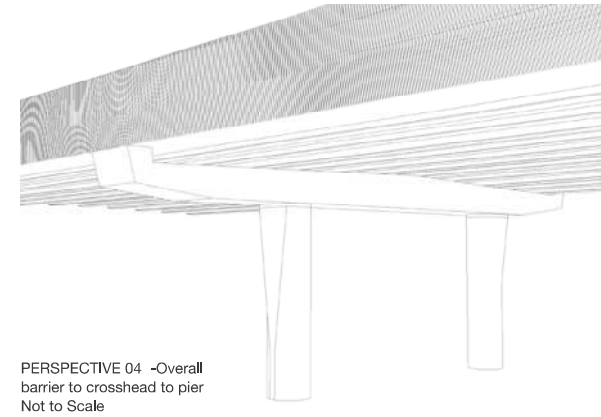
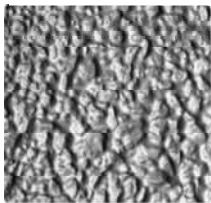
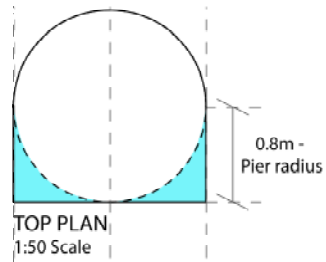

Figure 94. Bridge 5&1 Ōtaki River & Waitohu Stream Bridge Pier Profile



Bridge 5 & 1 - Ōtaki River & Waitohu Stream Bridge Pier Profile



Illustrative - exposed aggregate textured appearance, achieved with a formliner to the triangular face



Illustrative - Off the form standard concrete finish to pier profile

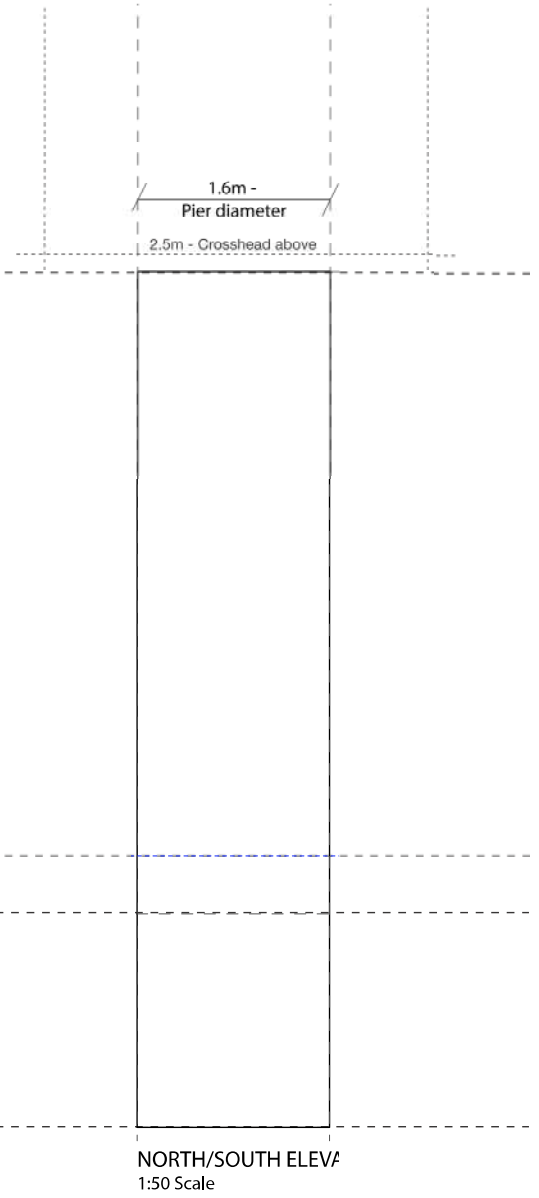
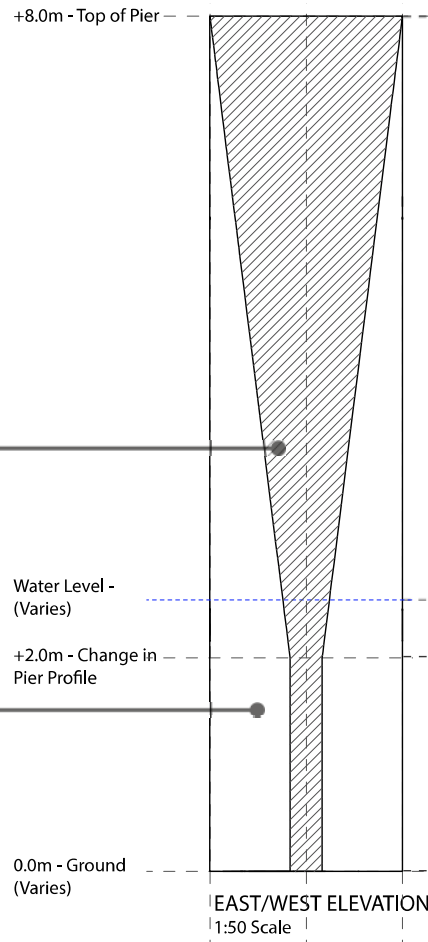
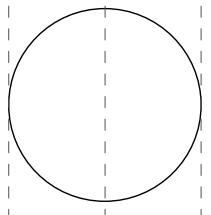

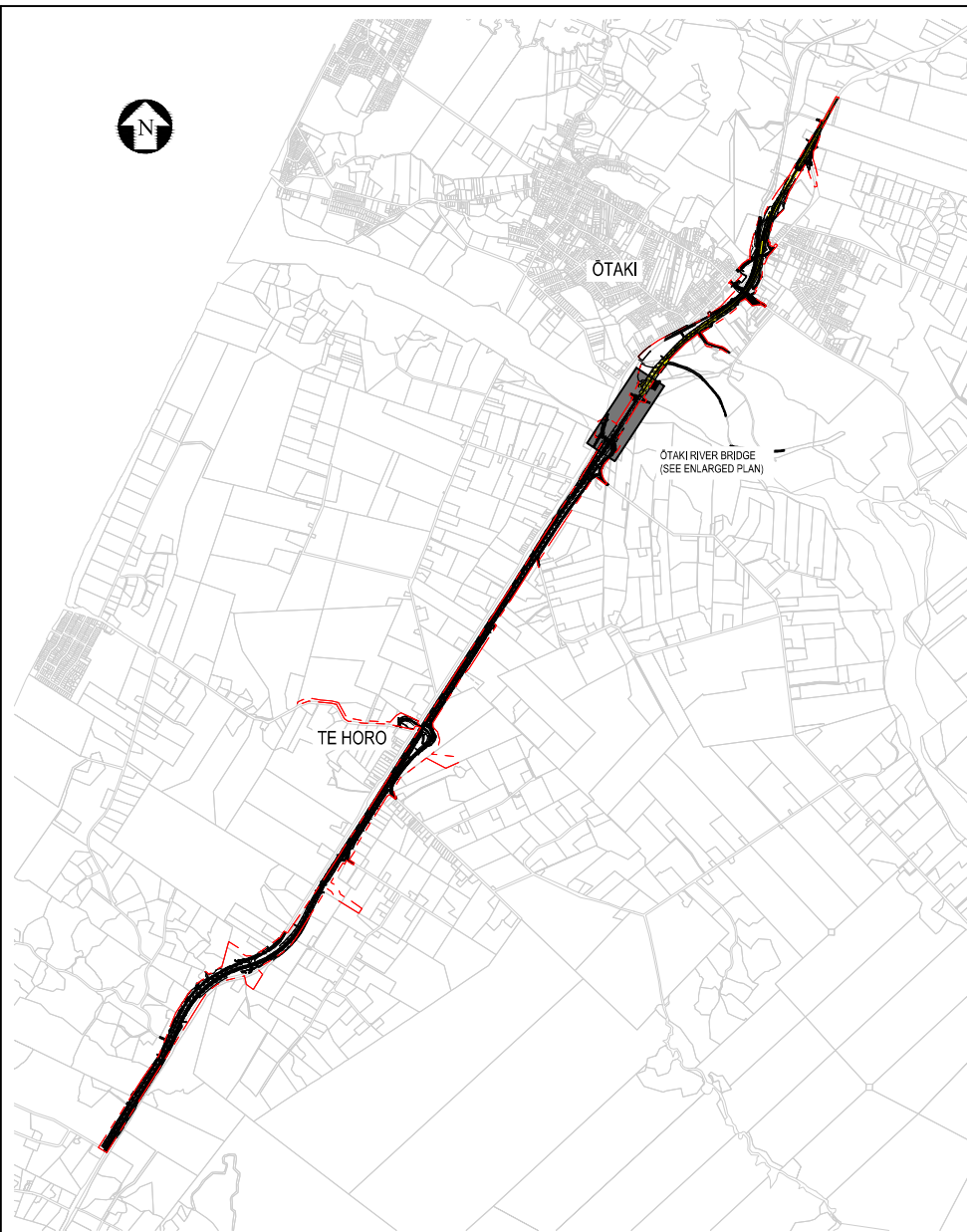

LOCATION PLAN  
NTS

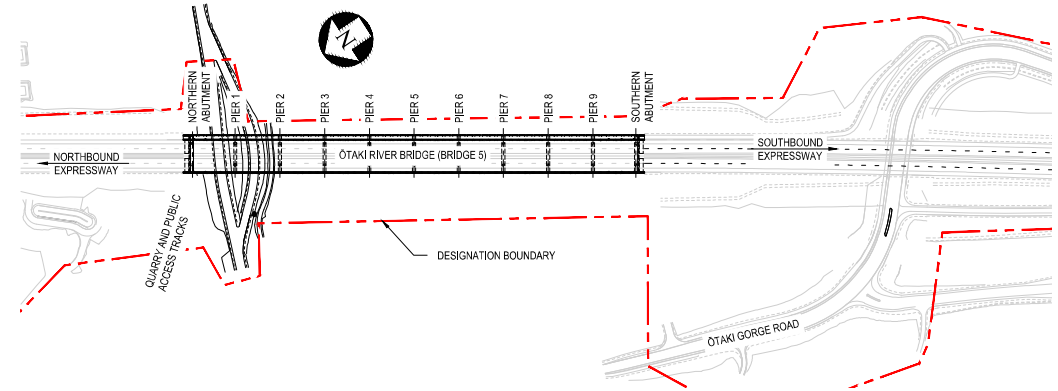

ENLARGED PLAN  
NTS

STRUCTURAL DRAWING LIST

| DRAWING NUMBER   | DRAWING NAME                                     | REVISION |
|------------------|--|----------|
| GENERAL NOTES    |  |          |
| PP20-DR-SA-0001  | GENERAL NOTES                                    | 2        |
| PP20-DR-SA-0002  | GENERAL NOTES - REINFORCED CONCRETE SHEET 1      | 1        |
| PP20-DR-SA-0003  | GENERAL NOTES - REINFORCED CONCRETE SHEET 2      | 1        |
| PP20-DR-SA-0004  | GENERAL NOTES - STRUCTURAL STEEL                 | 1        |
| PROJECT DRAWINGS |  |          |
| PP20-DR-SB-5000  | STRUCTURAL DRAWINGS COVER SHEET AND DRAWING LIST | E        |
| PP20-DR-SB-5001  | GENERAL ARRANGEMENT PLAN SHEET 1                 | E        |
| PP20-DR-SB-5002  | GENERAL ARRANGEMENT PLAN SHEET 2                 | E        |
| PP20-DR-SB-5011  | GENERAL ARRANGEMENT SECTIONS SHEET 1             | E        |
| PP20-DR-SB-5012  | GENERAL ARRANGEMENT SECTIONS SHEET 2             | E        |
| PP20-DR-SB-5013  | GENERAL ARRANGEMENT SECTIONS SHEET 3             | E        |
| PP20-DR-SB-5021  | GENERAL ARRANGEMENT SUBSTRUCTURE SETOUT PLAN     | 0        |
| PP20-DR-SB-5022  | BORED PILE DETAILS                               | 0        |
| PP20-DR-SB-5031  | ABUTMENT CONCRETE SHEET 1                        | 0        |
| PP20-DR-SB-5032  | ABUTMENT CONCRETE SHEET 2                        | 0        |
| PP20-DR-SB-5041  | ABUTMENT REINFORCEMENT SHEET 1                   | 0        |
| PP20-DR-SB-5042  | ABUTMENT REINFORCEMENT SHEET 2                   | 0        |
| PP20-DR-SB-5043  | ABUTMENT REINFORCEMENT SHEET 3                   | 0        |
| PP20-DR-SB-5044  | ABUTMENT REINFORCEMENT SHEET 4                   | 0        |
| PP20-DR-SB-5051  | PIER COLUMN CONCRETE                             | 0        |
| PP20-DR-SB-5052  | PIER CROSSHEAD BEAM CONCRETE SHEET 1             | C        |
| PP20-DR-SB-5053  | PIER CROSSHEAD BEAM CONCRETE SHEET2              | D        |
| PP20-DR-SB-5054  | COLUMN SLEEVE DETAILS                            | B        |
| PP20-DR-SB-5061  | PIER COLUMN REINFORCEMENT                        | 0        |
| PP20-DR-SB-5062  | PIER CROSSHEAD BEAM REINFORCEMENT SHEET 1        | C        |
| PP20-DR-SB-5063  | PIER CROSSHEAD BEAM REINFORCEMENT SHEET 2        | B        |
| PP20-DR-SB-5081  | VERTICAL GUIDE BEARING DETAILS                   | C        |
| PP20-DR-SB-5082  | ELASTOMERIC BEARING DETAILS                      | D        |
| PP20-DR-SB-5083  | POT BEARING DETAILS                              | C        |
| PP20-DR-SB-5084  | BEARING LAYOUT PLAN                              | B        |
| PP20-DR-SB-5101  | SUPERSTRUCTURE CONCRETE SHEET 1                  | C        |
| PP20-DR-SB-5102  | SUPERSTRUCTURE CONCRETE SHEET 2                  | C        |
| PP20-DR-SB-5103  | SUPERSTRUCTURE CONCRETE SHEET 3                  | C        |
| PP20-DR-SB-5104  | SUPERSTRUCTURE CONCRETE SHEET 4                  | B        |
| PP20-DR-SB-5161  | SUPERSTRUCTURE REINFORCEMENT SHEET 1             | C        |
| PP20-DR-SB-5162  | SUPERSTRUCTURE REINFORCEMENT SHEET 2             | C        |
| PP20-DR-SB-5163  | SUPERSTRUCTURE REINFORCEMENT SHEET 3             | C        |
| PP20-DR-SB-5164  | SUPERSTRUCTURE REINFORCEMENT SHEET 4             | B        |

STRUCTURAL DRAWING LIST

| DRAWING NUMBER    | DRAWING NAME   | REVISION |
|-------------------|--|----------|
| PP20-DR-SB-5171   | EXPANSION JOINT DETAILS                                | C        |
| PP20-DR-SB-5172   | STEEL COVER PLATE DETAILS                              | C        |
| PP20-DR-SB-5181   | SERVICES DETAILS SHEET 1                               | C        |
| PP20-DR-SB-5182   | SERVICES DETAILS SHEET 2                               | B        |
| PP20-DR-SB-5191   | EARLY EMBANKMENT CONSTRUCTION                          | B        |
| PP20-DR-SB-5192   | SETTLEMENT INSTRUMENTATION AND MONITORING              | B        |
| PP20-DR-SB-5193   | EARTHWORKS, BACKFILLING AND DRAINAGE                   | B        |
| PP20-DR-SB-5201   | SCOUR PROTECTION DETAILS                               | A        |
| STANDARD DRAWINGS |  |          |
| PP20-DR-SD-0010   | NOTES FOR PRECAST AND PRE-TENSIONED BRIDGE BEAMS       | 1        |
| PP20-DR-SD-0011   | 1525 SUPER T BEAM - TYPICAL GEOMETRY                   | 1        |
| PP20-DR-SD-0012   | 1525 SUPER T BEAM - PRE-STRESSING DETAILS (33.5m SPAN) | C        |
| PP20-DR-SD-0014   | 1525 SUPER T BEAM - REINFORCEMENT DETAILS SHEET 1      | 1        |
| PP20-DR-SD-0016   | 1525 SUPER T BEAM - REINFORCEMENT DETAILS SHEET 3      | C        |
| PP20-DR-SD-0031   | SUPER T BEAM - COMMON DETAILS                          | 1        |
| PP20-DR-SD-0101   | TL5 PRECAST BARRIER SHEET 1                            | 1        |
| PP20-DR-SD-0102   | TL5 PRECAST BARRIER SHEET 2                            | 1        |
| PP20-DR-SD-0103   | TL5 PRECAST BARRIER SHEET 3                            | B        |
| PP20-DR-SD-0201   | TEXAS T80HT RAIL SHEET 1                               | 1        |
| PP20-DR-SD-0202   | TEXAS T80HT RAIL SHEET 2                               | 1        |
| PP20-DR-SD-0301   | PEDESTRIAN BARRIER SHEET 1                             | B        |
| PP20-DR-SD-0302   | PEDESTRIAN BARRIER SHEET 2                             | A        |
| PP20-DR-SD-0401   | SETTLEMENT SLAB DETAILS                                | 1        |

| No. | Revision           | By  | Chk | Appr | Date     |
|-----|--------------------|-----|-----|------|----------|
| E   | 100% DESIGN REVIEW | CRB | LZC | JK   | 20.12.17 |
| D   | 80% DESIGN REVIEW  | CRB | LZC | JK   | 17.10.17 |
| C   | 30% DESIGN REVIEW  | CRB | LZC | JK   | 17.08.17 |
| B   | 80% DESIGN REVIEW  | CRB | LZC | JK   | 22.05.17 |

| Scale (A1)     | AS SHOWN | Scale (A3) |
|----------------|----------|------------|
| Design         | L.CHEN   | 17.02.17   |
| Drawn          | C.BURKE  | 07.02.17   |
| Disc. Verifier | G.BROWN  | 15.05.17   |
| Dwg Check      | B.FLYNN  | 22.05.17   |

|          |   |              |                 |
|----------|---|--------------|-----------------|
| Subject: | OTAKI RIVER BRIDGE (BRIDGE 5)                       | Discipline:  | STRUCTURAL      |
| Title:   | STRUCTURAL DRAWINGS<br>COVER SHEET AND DRAWING LIST | Drawing No.: | PP20-DR-SB-5000 |
|          |   | Rev.:        | E               |

**FOR INFORMATION  
NOT FOR CONSTRUCTION**

ORIGINAL IN COLOUR

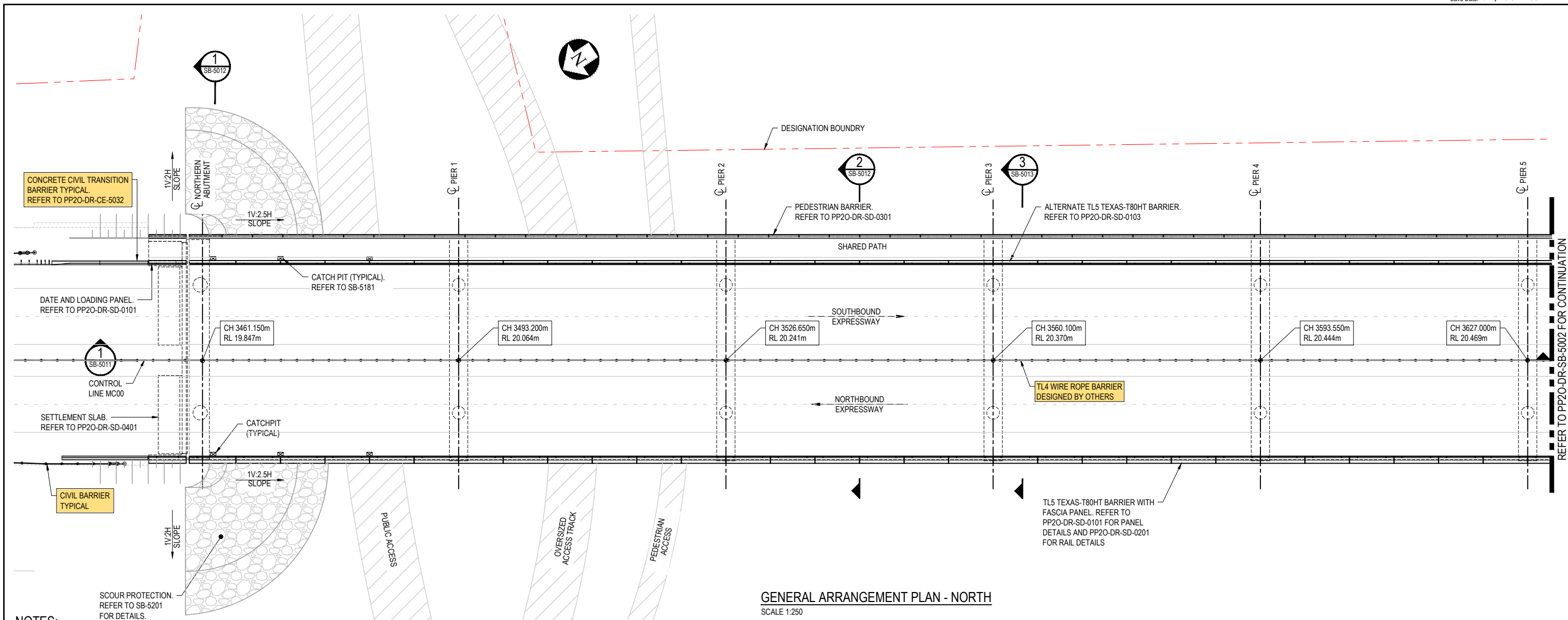

GENERAL ARRANGEMENT PLAN - NORTH  
SCALE 1:250

NOTES:

1. REFERENCES
  - 1.1. REFER TO PP20-DR-SA-0001 TO PP20-DR-SA-0004 FOR GENERAL NOTES.
  - 1.2. REFER TO RELEVANT CIVIL DRAWINGS FOR ROADING GEOMETRY, BARRIER EXTENTS, LANE WIDTHS ETC.
  - 1.3. REFER TO RELEVANT CIVIL DRAWINGS FOR LOCATION OF UTILITIES AND SERVICES.
  - 1.4. ALL LEVELS GIVEN ARE TO STRUCTURAL SURFACE UNO.
2. DESIGN STANDARDS
  - 2.1. NZTA BRIDGE MANUAL, THIRD EDITION (AMENDMENT 1, SEPT. 2014), WITH PROJECT SPECIFIC AMENDMENTS.
  - 2.2. NZS 3101:2006 CONCRETE STRUCTURES STANDARD WITH PROJECT SPECIFIC AMENDMENTS.
  - 2.3. REFER TO DESIGN STATEMENT REPORT FOR FURTHER DETAILS.
3. DESIGN LOADING
  - 3.1. SUPERIMPOSED DEAD LOAD ALLOWANCE:
    - a) SURFACING = 2.0kPa (INCLUDING 0.5kPa FOR LEVELLING COURSE)
    - b) SERVICES = ALLOWANCES ARE MADE AS FOLLOWS
      - i) 1 No 100mm TELECOMMUNICATIONS DUCT
      - ii) 2 No 150mm DUCTS FOR FUTURE SERVICES (ONE ON EACH SIDE)
      - iii) PLUS ADDITIONAL UNIFORMLY DISTRIBUTED LOAD APPLIED OVER ENTIRE DECK AREA OF 0.25kPa
    - 3.2. TRAFFIC LOAD HN-HO-72
    - 3.3. SEISMIC LOAD BASED ON NZS1170.5 & SSSHA STUDY WITH:
      - a) SUBSOIL CLASS D
      - b) ULS AEP (1/2500)
      - c) ULS DESIGN ACCELERATION 0.295g TRANSVERSE 0.113g LONGITUDINAL
    - 3.4. TEMPERATURE AND DIFFERENTIAL TEMPERATURE AS PER NZTA BRIDGE MANUAL.
    - 3.5. CREEP AND SHRINKAGE BASED ON AS3600 AND NZTA BRIDGE MANUAL 3rd EDITION FOR RELATIVE HUMIDITY 80%.
    - 3.6. JACKING OF BRIDGE DECK FOR BEARING/ HORIZONTAL RESTRAINT REPLACEMENT THE DESIGN INCLUDES THE FOLLOWING REQUIREMENTS:
      - a) TRAFFIC SHALL BE RESTRICTED TO 40km/h.
      - b) SEE ABUTMENT AND PIER DRAWINGS FOR JACKING LOCATIONS AND LOADS.
      - c) JACKING LOADS ARE BASED ON HN LOADINGS
      - d) ALL JACKS AT EACH DIAPHRAGM SHALL BE HYDRAULICALLY LINKED AND HAVE A CENTRAL MECHANISM TO ENSURE THAT THE SAME VERTICAL DISPLACEMENTS OCCUR AT EACH JACKING POINT AT ALL TIMES DURING THE JACKING OPERATION.
      - e) AT PIER LOCATIONS BOTH BEAM ENDS ON THAT PIER SHALL BE JACKED UP SIMULTANEOUSLY.
  4. DRAWING LIST
    - 4.1. FOR THE LIST OF ALL DRAWINGS APPLICABLE TO THIS BRIDGE, REFER TO DRG. SB-5000.
  5. SPECIFICATIONS APPLICABLE TO THIS BRIDGE:
    - 5.1. C0203 - BULK EARTHWORKS
    - 5.2. C0226 - ROCK ARMOUR
    - 5.3. C0310 - INSTRUMENTATION AND MONITORING
    - 5.4. C0501 - BORED PILES
    - 5.5. C0600 - REINFORCED CONCRETE SUPPLY
    - 5.6. C0601 - REINFORCED CONCRETE CONSTRUCTION
    - 5.7. C0607 - PRESTRESSED CONCRETE ELEMENTS
    - 5.8. C0614 - ANTI-GRAFFITI COATINGS
    - 5.9. C0700 - STRUCTURAL STEELWORKS
  6. CONSTRUCTION LOADS
    - 6.1. BRIDGE BEAMS ARE DESIGNED FOR CONSTRUCTION LIVE LOAD OF 1.5kPa. TEMPORARY WORK SHALL BE ADEQUATE FOR 1/500 APE (R = 1.0) SEISMIC AND WIND LOADING.
  7. STRUCTURAL ELEMENTS INCLUDED IN PACKAGE:
    - 7.1. BRIDGE PILES, PIER COLUMNS, ABUTMENTS, SETTLEMENT SLABS, CROSSHEAD BEAMS, PRESTRESSED BEAMS, WING WALLS, BEARINGS, EXPANSION JOINTS, TL5 T80HT TRAFFIC BARRIERS WITH FASCIA AND PEDESTRIAN BARRIERS INCLUDING HANDRAILS.
    - 7.2. TRAFFIC BARRIERS DETAILED IN THE STRUCTURAL DRAWINGS TERMINATE AT THE EXTENT OF THE BARRIERS ON WING WALL (BARRIERS BEYOND THAT ARE CONSIDERED TO BE STANDARD ROAD TRAFFIC BARRIERS. FOR THESE REFER TO THE RELEVANT CIVIL DRAWINGS).
  8. COATING FOR EXPOSED SURFACES:
    - 8.1. GRAFFITI SOLUTION (OR EQUIVALENT APPROVED BY THE DESIGNER) SHALL BE APPLIED TO THE EXPOSED CONCRETE SURFACES TO THE EXTENT SUMMARISED IN TABLE 1.
    - 8.2. FOR THE APPLICATION OF SURFACE COATING, PLEASE REFER TO THE SPECIFICATION C0614.
  - f) BRIDGE BEARINGS ARE DESIGNED TO BE REPLACED USING LIFTS OF NOT GREATER THAN 10mm.
  - g) STEEL PLATES SHALL BE PLACED BETWEEN CONCRETE BEARING SURFACE AND HYDRAULIC JACK.
  - h) MAXIMUM ALLOWABLE CONTACT PRESSURE BETWEEN CONCRETE SURFACE AND STEEL PLATE SHALL BE 25MPa.
  - i) HORIZONTAL RESTRAINTS AT ABUTMENTS SHALL BE MAINTAINED.

TABLE 1. SURFACE COATINGS

| BRIDGE ELEMENTS | EXPOSED SURFACE   | ANTI-GRAFFITI COATING |
|-----------------|---|-----------------------|
| BRIDGE BARRIER  | INSIDE FACES (FACING EXPRESSWAY)                          | YES                   |
|                 | TOP SURFACE, OUTSIDE FACE OF FASCIA                       | YES                   |
| ABUTMENTS       | FRONT FACES (FACING LOCAL ROADS)                          | YES                   |
|                 | SIDES OF ABUTMENTS  | YES                   |
| PIER CROSSHEADS | ALL EXPOSED AREAS   | NO                    |
| COLUMNS         | ALL EXPOSED SURFACES TO FULL HEIGHT                       | YES                   |
| DECK SOFFIT     | 1.5m HORIZONTALLY FROM AN ACCESSIBLE SUBSTRUCTURE ELEMENT | YES                   |

9. AFTER AN EARTHQUAKE EVENT, REFER TO SECTION 3.3 OF THE "PEKA PEKA TO ŌTAKI EXPRESSWAY BRIDGE 5: ŌTAKI RIVER BRIDGE, DESIGN STATEMENT" FOR POSSIBLE TEMPORARY REPAIRS AT THE BRIDGE JOINTS IN ORDER TO OPEN THE BRIDGE TO EMERGENCY TRAFFIC.
10. AFTER A SLS EARTHQUAKE EVENT, THE PEDESTRIAN BARRIER COMPRESSION MECHANISM AT THE EXPANSION JOINTS SHALL BE CHECKED AND REPAIRED IF DAMAGED TO REINSTATE THE GAPS TO A MAXIMUM OF 100mm.
11. AFTER A SLS FLOOD EVENT, SCOUR AT THE PIERS SHALL BE INSPECTED, AND REINSTATED IF SCOUR EXCEEDS 1.5m BELOW THE TOP OF THE PILE.

12. CONSTRUCTION SEQUENCE:

TABLE 2. CONSTRUCTION SEQUENCE

| SEQUENCE | ACTIVITY  |
|----------|---|
| 1        | CARRY OUT PROOF BORES.  |
| 2        | INSTALL SETTLEMENT MONITORING.  |
| 3        | BUILD ABUTMENT EMBANKMENTS.   |
|          | PRELOAD ABUTMENTS TO UNDERSIDE OF PAVEMENT AND ALLOW 3 MONTHS FOR SETTLEMENT PRIOR TO PILING OF ABUTMENT PILES. SETTLEMENT MONITORING OF EMBANKMENT IS REQUIRED. GEOTECHNICAL DESIGN ENGINEER TO CONFIRM 95% PRIMARY CONSOLIDATION SETTLEMENT COMPLETE PRIOR TO ABUTMENT PILE CONSTRUCTION. |
| 4        | BORE AND CONSTRUCT PIER PILES AND PLUNGE COLUMN CAGE IN WET PILE CONCRETE.  |
| 5        | TRIM EXCESS PRELOAD AND CUT BENCH IN EMBANKMENT BETWEEN ABUTMENT PILES FOR PILING PLATFORM.   |
| 6        | CONSTRUCT PIER COLUMNS.   |
| 7        | CONSTRUCT PIER CROSSHEAD AND ABUTMENT BEAMS.  |
| 8        | CONSTRUCT ABUTMENT WINGWALLS AND BACK WALLS, FILL TO SETTLEMENT SLAB LEVEL.   |
| 9        | CONSTRUCT SETTLEMENT SLAB AND FILL TO ROAD LEVEL.   |
| 10       | INSTALL BEARINGS.   |
| 11       | INSTALL PRECAST 1525 SUPER T BEAMS.   |
| 12       | CAST DIAPHRAGMS.  |
| 13       | POUR DECK SLAB.   |
| 14       | INSTALL ROAD JOINTS SERVICES AND DRAINAGE SYSTEM.   |
| 15       | INSTALL BARRIERS.   |
| 16       | LAY LEVELLING COURSE AND SURFACING.   |

THE ABOVE CONSTRUCTION SEQUENCE SHOWS THE SEQUENCING AS ASSUMED FOR DESIGN PURPOSES. CONSTRUCTOR TO ADVISE DESIGNER IF ALTERNATIVE CONSTRUCTION SEQUENCE IS PROPOSED.



**FOR CONSTRUCTION**

|  |              |         |          |                           |
|--|--------------|---------|----------|---------------------------|
| Scale (A1) AS SHOWN                        | Design       | L.CHEN  | 17.02.17 | Approved For Construction |
| Scale (A3)                                 | Drawn        | C.BURKE | 07.02.17 |                           |
|  | Dwg Verifier | G.BROWN | 15.05.17 |                           |
|  | Dwg Check    | B.FLYNN | 22.05.17 | Date                      |
| * Refer to Original Hardcopy for Signature |              |         |          |                           |

NZ TRANSPORT AGENCY  
**Peka Peka to Ōtaki Expressway**  
 Fletcher HIGGINS  
 BECA  
 Tonkin+Taylor

|          |                                  |              |                 |
|----------|----------------------------------|--------------|-----------------|
| Subject: | ŌTAKI RIVER BRIDGE (BRIDGE 5)    | Discipline:  | STRUCTURAL      |
| Title:   | GENERAL ARRANGEMENT PLAN SHEET 1 | Drawing No.: | PP20-DR-SB-5001 |
|          |                                  | Rev.:        | 1               |

Document No. R13000 - DESIGN DEVELOPMENT GENERAL09 CADDRAWINGS\SS\PP20-DR-SB-5001.DWG

- NOTES:**  
 1. REFER TO PP20-DR-SA-0001 TO PP20-DR-SA-0004 FOR GENERAL NOTES.  
 2. REFER TO PP20-DR-SB-5001 FOR BRIDGE SPECIFIC NOTES.

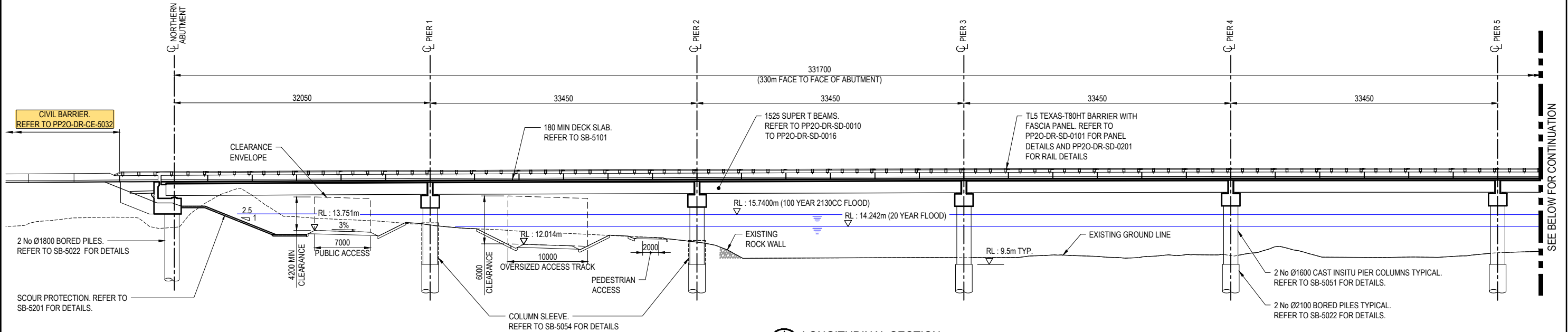

1 LONGITUDINAL SECTION  
 SB-5001 SCALE 1:250

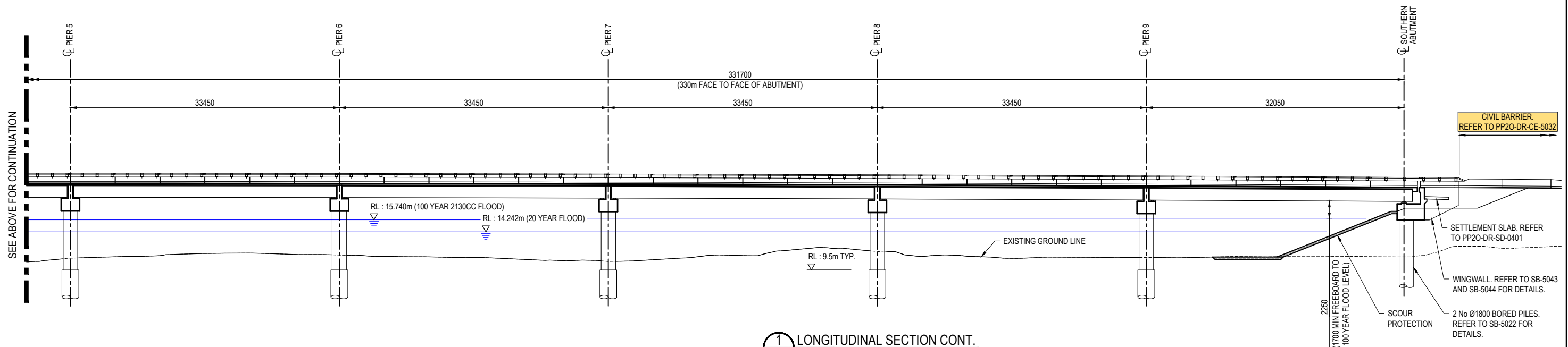

1 LONGITUDINAL SECTION CONT.  
 SB-5002 SCALE 1:250

**FOR CONSTRUCTION**

|     |                  |     |     |      |          |
|-----|------------------|-----|-----|------|----------|
| No. | Revision         | By  | Chk | Appt | Date     |
| 1   | FOR CONSTRUCTION | CRB | LZC | JK   | 04.04.18 |

|                        |               |         |          |                           |
|------------------------|---------------|---------|----------|---------------------------|
| Scale (A1)<br>AS SHOWN | Design        | L.CHEN  | 17.02.17 | Approved For Construction |
| Scale (A3)             | Drawn         | C.BURKE | 07.02.17 |                           |
|                        | Draw Verifier | G.BROWN | 15.05.17 |                           |
|                        | Draw Check    | B.FLYNN | 22.05.17 | Date                      |

\* Refer to Original Hardcopy for Signature

NZ TRANSPORT AGENCY  
 Peka Peka to Ōtaki Expressway  
 Fletcher HIGGINS  
 BECA  
 Tonkin+Taylor

|          |                                      |              |                 |
|----------|--------------------------------------|--------------|-----------------|
| Subject: | ŌTAKI RIVER BRIDGE (BRIDGE 5)        | Discipline:  | STRUCTURAL      |
| Title:   | GENERAL ARRANGEMENT SECTIONS SHEET 1 | Drawing No.: | PP20-DR-SB-5011 |

|      |   |
|------|---|
| Rev. | 1 |
|------|---|

**NOTES:**  
 1. REFER TO PP20-DR-SA-0001 TO PP20-DR-SA-0004 FOR GENERAL NOTES.  
 2. REFER TO PP20-DR-SB-5001 FOR BRIDGE SPECIFIC NOTES.

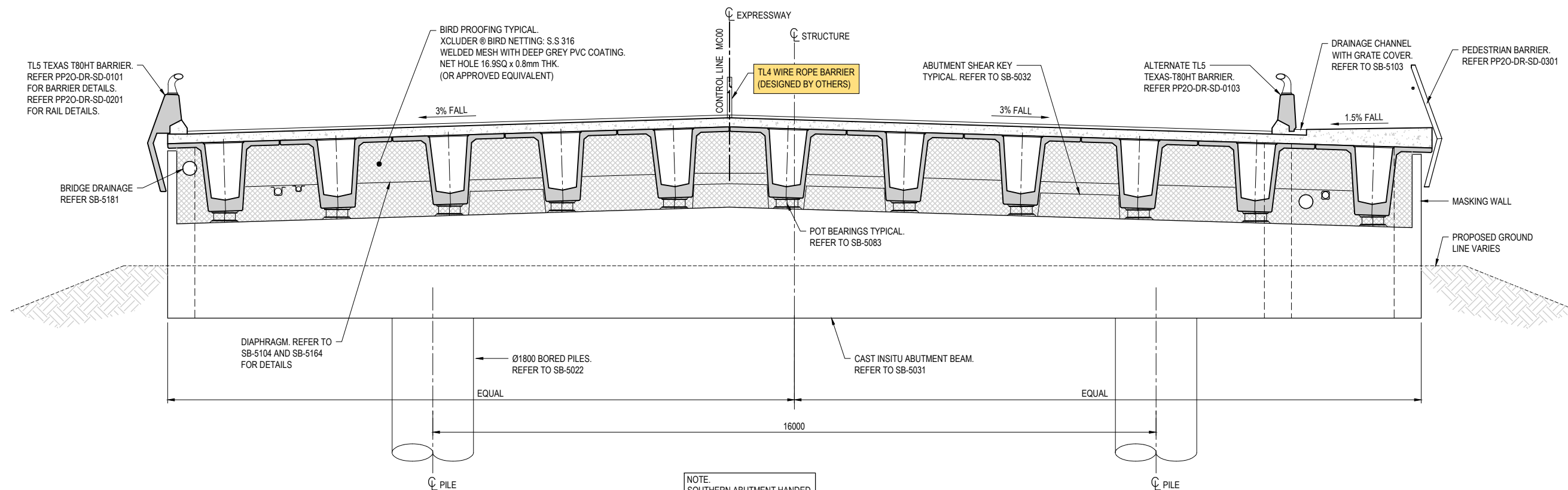

**1 NORTHERN ABUTMENT ELEVATION**  
 SB-5001 SCALE 1:50

NOTE:  
SOUTHERN ABUTMENT HANDED

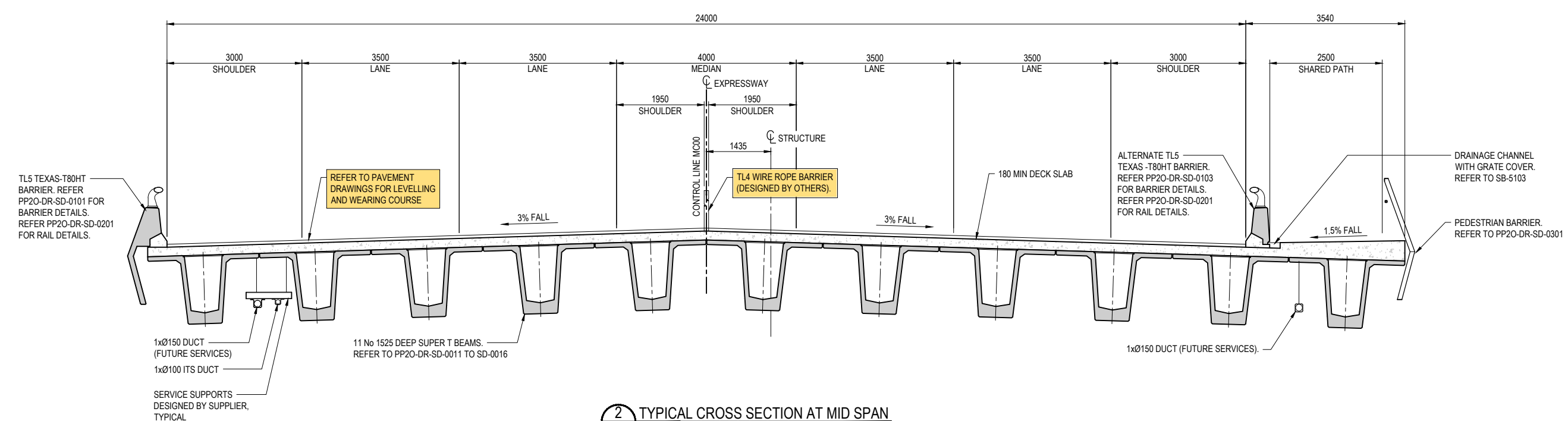

**2 TYPICAL CROSS SECTION AT MID SPAN**  
 SB-5001 SCALE 1:50

**FOR CONSTRUCTION**

|     |                  |     |     |      |          |
|-----|------------------|-----|-----|------|----------|
| 1   | FOR CONSTRUCTION | CRB | LZC | JK   | 04.04.18 |
| No. | Revision         | By  | Chk | Appd | Date     |

|            |          |              |         |          |                           |
|------------|----------|--------------|---------|----------|---------------------------|
| Scale (A1) | AS SHOWN | Design       | L.CHEN  | 17.02.17 | Approved For Construction |
| Scale (A3) |          | Drawn        | C.BURKE | 07.02.17 |                           |
|            |          | Dwg Verifier | G.BROWN | 15.05.17 | Date                      |
|            |          | Dwg Check    | B.FLYNN | 22.05.17 |                           |

\* Refer to Original Hardcopy for Signature

NZ TRANSPORT AGENCY WAIKAŌTIRI

Peka Peka to Ōtaki Expressway

Fletcher HIGGINS

BECA

Tonkin+Taylor

|          |                                      |              |                 |
|----------|--------------------------------------|--------------|-----------------|
| Subject: | ŌTAKI RIVER BRIDGE (BRIDGE 5)        | Discipline:  | STRUCTURAL      |
| Title:   | GENERAL ARRANGEMENT SECTIONS SHEET 2 | Drawing No.: | PP20-DR-SB-5012 |
|          |                                      | Rev.:        | 1               |

Document No. R13000 - DESIGN DEVELOPMENT GENERAL/09 CAD/DRAWINGS/PP20-DR-SB-5012.DWG



**NOTES:**  
 1. REFER TO PP20-DR-SA-0001 TO PP20-DR-SA-0004 FOR GENERAL NOTES.  
 2. REFER TO PP20-DR-SB-5001 FOR BRIDGE SPECIFIC NOTES.

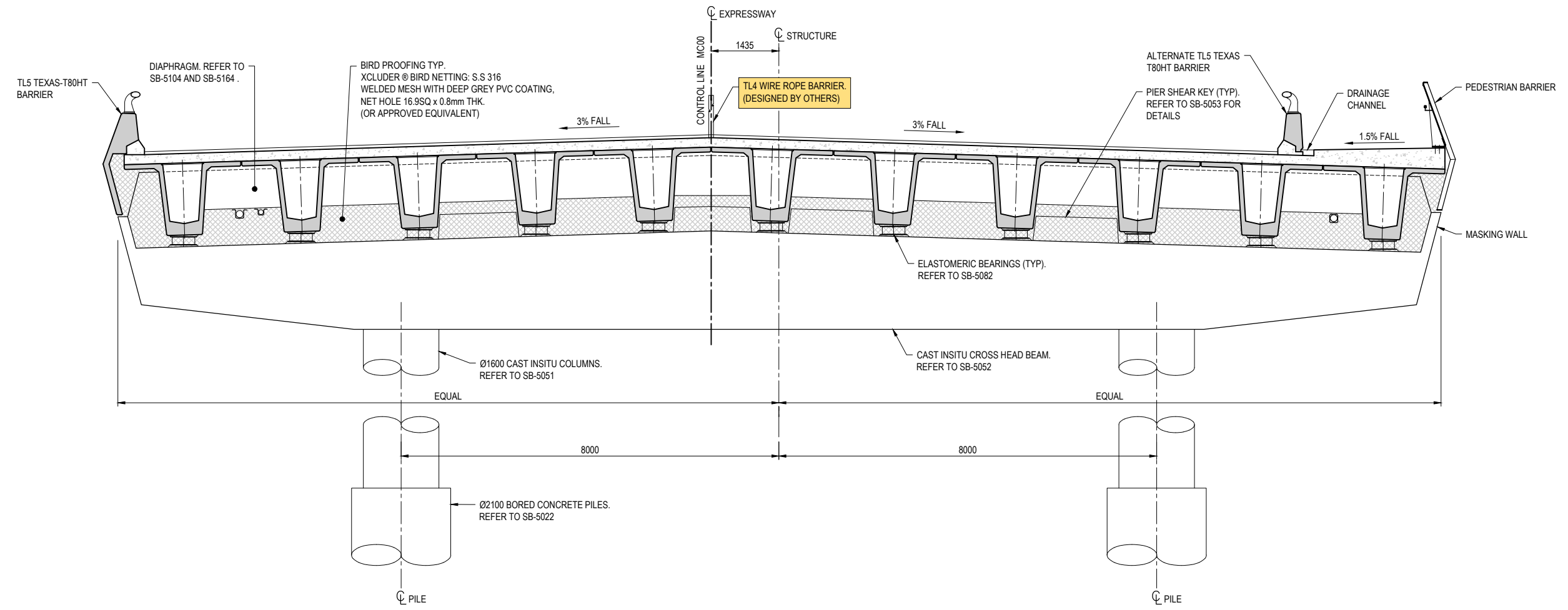

**3** TYPICAL CROSS SECTION AT PIER  
 SB-5001 SCALE 1:50

**FOR CONSTRUCTION**

|     |                  |     |     |      |          |
|-----|------------------|-----|-----|------|----------|
| No. | Revision         | By  | Chk | Appt | Date     |
| 1   | FOR CONSTRUCTION | CRB | LZC | JK   | 04.04.18 |

|                     |              |         |          |                           |
|---------------------|--------------|---------|----------|---------------------------|
| Scale (A1) AS SHOWN | Design       | L.CHEN  | 17.02.17 | Approved For Construction |
| Scale (A3)          | Drawn        | C.BURKE | 07.02.17 |                           |
|                     | Dwg Verifier | G.BROWN | 15.05.17 |                           |
|                     | Dwg Check    | B.FLYNN | 22.05.17 | Date                      |

\* Refer to Original Hardcopy for Signature

NZ TRANSPORT AGENCY | Peka Peka to Ōtaki Expressway | Fletcher HIGGINS | BECA | Tonkin+Taylor

|          |                                      |
|----------|--------------------------------------|
| Subject: | ŌTAKI RIVER BRIDGE (BRIDGE 5)        |
| Title:   | GENERAL ARRANGEMENT SECTIONS SHEET 3 |

|              |                 |
|--------------|-----------------|
| Discipline:  | STRUCTURAL      |
| Drawing No.: | PP20-DR-SB-5013 |
| Rev.:        | 1               |

**NOTES:**

1. REFER TO PP20-DR-SA-0001 TO PP20-DR-SA-0004 FOR GENERAL NOTES.
2. REFER TO PP20-DR-SB-5001 FOR BRIDGE SPECIFIC NOTES.
3. THIS DRAWING SHALL BE READ IN CONJUNCTION WITH PP20-DR-SB-5022.
4. TABLE 1 SHOWS PRELIMINARY PILE TOE ELEVATIONS ONLY. THIS SHALL BE CONFIRMED BY THE GEOTECHNICAL DESIGN ENGINEER BASED ON RESULTS OF PROOF BORES.
5. PROOF BORES SHALL BE DRILLED AT LOCATIONS PRESENTED IN TABLE. PROOF BORES SHALL BE LOGGED BY GEOTECHNICAL DESIGN ENGINEER (OR REPRESENTATIVE). REFER TO C0501-BORED PILE SPECIFICATION FOR PROOF BOREHOLE REQUIREMENTS. BORES SHALL BE SONIC DRILLED (PQ SIZE) WITH SPT TESTING AT 1.5m CRS. PROOF BORES SHALL BE LOCATED 1.5m FROM PILE CENTRE, IN LINE WITH THE PIER HEADSTOCK.
6. SEE PROOF BORE INVESTIGATION TARGET RLs. PROOF BORES SHALL ONLY BE TERMINATED WHEN INSTRUCTED TO DO SO BY THE GEOTECHNICAL DESIGN ENGINEER. THE GEOTECHNICAL DESIGN ENGINEER WILL NEED TO HAVE RECEIVED AND REVIEWED THE DAILY DRILL RECORDS FOR A PARTICULAR BOREHOLE BEFORE INSTRUCTING THE CONTRACTOR TO TERMINATE THAT BOREHOLE.
7. ADDITIONAL PROOF BORES MAY BE REQUIRED BY THE GEOTECHNICAL DESIGN ENGINEER IF PROOF BORES ENCOUNTER VARIABLE GROUND CONDITIONS.
8. PILES MUST HAVE DENSE GRAVEL OR GRAVELLY SAND (SPT N>30) 3 PILE DIAMETERS (D) ABOVE AND 5D BELOW PILE FOUNDING DEPTH. IF ANY OF THE SPT N VALUES ARE LESS THAN 30 OR SILT/CLAY IS ENCOUNTERED, THE GEOTECHNICAL DESIGN ENGINEER MUST BE INFORMED AND THE PILE DESIGN DEPTH RE-ASSESSED.
9. BORES SHALL BE BACKFILLED WITH GROUT ON COMPLETION.
10. NO CONCRETING SHALL BEGIN UNTIL THE GEOTECHNICAL DESIGN ENGINEER HAS INSPECTED AND APPROVED THE FOUNDING OF THE PILE. THE DEPTH OF THE PILE EXCAVATION SHALL BE VERIFIED BY THE CONTRACTOR USING THE PILING EQUIPMENT DURING THIS INSPECTION.

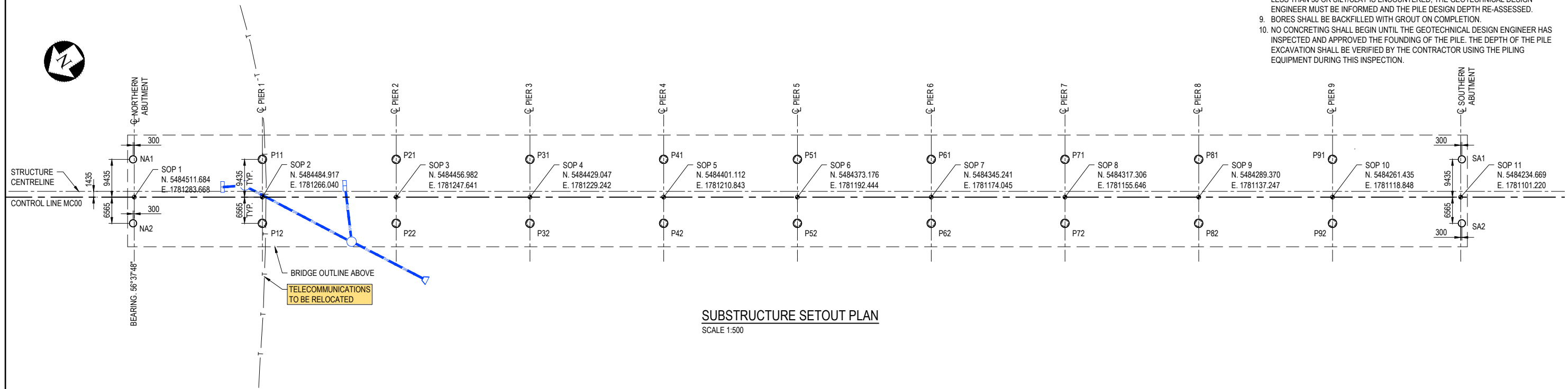

**TABLE 1. PILE DATA**

| PILE LOCATION | DESIGN    |                 |                    |                                 | GEOTECHNICAL DEPENDABLE COMPRESSION CAPACITY WITH SRF, ØN (kN) | MAXIMUM ULS AXIAL LOAD (kN) | PROOF BORE INVESTIGATION  |  |                           | PROOF BORE COMPLETED |
|---------------|-----------|-----------------|--------------------|---------------------------------|--|-----------------------------|---------------------------|--|---------------------------|----------------------|
|               | PILE SIZE | PILE TOE (RL m) | TOP OF PILE (RL m) | BASE OF TEMPORARY CASING (RL m) |  |                             | PROOF BORE (REFER NOTE 5) | START SPT TESTING RL (MIN No OF SPT TESTS) | PRELIMINARY TARGET RL (m) |                      |
| NA1           | Ø1800     | -13.100         | 15.570             | 3.570                           | 13600  | 13100                       | -                         | -  | -                         | -                    |
| NA2           |           |                 |                    |                                 |  |                             | Y                         | -6.0 (14 No.)                              | -26.0                     | Y                    |
| P11           | Ø2100     | -15.000         | 9.500              | -2.500                          | 17000  | 16600                       | Y                         | -6.0 (14 No.)                              | -26.0                     | N                    |
| P12           |           |                 |                    |                                 |  |                             | -                         | -  | -                         | -                    |
| P21           | Ø2100     | -15.000         | 9.500              | -2.500                          | 17000  | 16600                       | Y                         | -6.0 (14 No.)                              | -26.0                     | N                    |
| P22           |           |                 |                    |                                 |  |                             | -                         | -  | -                         | -                    |
| P31           | Ø2100     | -15.000         | 9.500              | -2.500                          | 17000  | 16600                       | Y                         | -2.5 (14 No.)                              | -22.5                     | N                    |
| P32           |           |                 |                    |                                 |  |                             | -                         | -  | -                         | -                    |
| P41           | Ø2100     | -13.500         | 9.500              | -2.500                          | 17000  | 16600                       | Y                         | -2.5 (14 No.)                              | -22.5                     | N                    |
| P42           |           |                 |                    |                                 |  |                             | -                         | -  | -                         | -                    |
| P51           | Ø2100     | -12.800         | 9.500              | -2.500                          | 17000  | 16600                       | Y                         | -2.5 (14 No.)                              | -22.5                     | Y                    |
| P52           |           |                 |                    |                                 |  |                             | -                         | -  | -                         | -                    |
| P61           | Ø2100     | -12.300         | 9.500              | -2.500                          | 17000  | 16600                       | Y                         | -2.5 (14 No.)                              | -22.5                     | Y                    |
| P62           |           |                 |                    |                                 |  |                             | -                         | -  | -                         | -                    |
| P71           | Ø2100     | -11.500         | 9.500              | -2.500                          | 17000  | 16600                       | Y                         | -2.5 (14 No.)                              | -22.5                     | Y                    |
| P72           |           |                 |                    |                                 |  |                             | -                         | -  | -                         | -                    |
| P81           | Ø2100     | -11.000         | 9.500              | -2.500                          | 17000  | 16600                       | Y                         | -2.5 (14 No.)                              | -22.5                     | Y                    |
| P82           |           |                 |                    |                                 |  |                             | -                         | -  | -                         | -                    |
| P91           | Ø2100     | -11.000         | 9.500              | -2.500                          | 17000  | 16600                       | Y                         | -2.5 (14 No.)                              | -22.5                     | Y                    |
| P92           |           |                 |                    |                                 |  |                             | -                         | -  | -                         | -                    |
| SA1           | Ø1800     | -11.000         | 15.450             | 3.450                           | 13600  | 13100                       | -                         | -  | -                         | -                    |
| SA2           |           |                 |                    |                                 |  |                             | Y                         | -1.0 (14 No.)                              | -21.0                     | Y                    |

**SERVICES LEGEND:**

| EXISTING | NEW |
|----------|-----|
|          |     |
|          |     |
|          |     |
|          |     |
|          |     |
|          |     |
|          |     |
|          |     |
|          |     |
|          |     |
|          |     |
|          |     |
|          |     |

**FOR CONSTRUCTION**

|     |                  |     |     |      |          |
|-----|------------------|-----|-----|------|----------|
| 1   | FOR CONSTRUCTION | CRB | LZC | JK   | 07.02.18 |
| No. | Revision         | By  | Chk | Appd | Date     |

|              |         |          |                           |
|--------------|---------|----------|---------------------------|
| Design       | L.CHEN  | 17.02.17 | Approved For Construction |
| Drawn        | C.BURKE | 07.02.17 | B.SYMMANS                 |
| Design Check | G.BROWN | 15.05.17 |                           |
| Design Check | B.FLYNN | 22.05.17 | Date 07.02.18             |

\* Refer to Original Hardcopy for Signature

|          |   |              |                 |
|----------|---|--------------|-----------------|
| Subject: | ŌTAKI RIVER BRIDGE (BRIDGE 5)                   | Discipline:  | STRUCTURAL      |
| Title:   | GENERAL ARRANGEMENT<br>SUBSTRUCTURE SETOUT PLAN | Drawing No.: | PP20-DR-SB-5021 |
|          |   | Rev.:        | 1               |

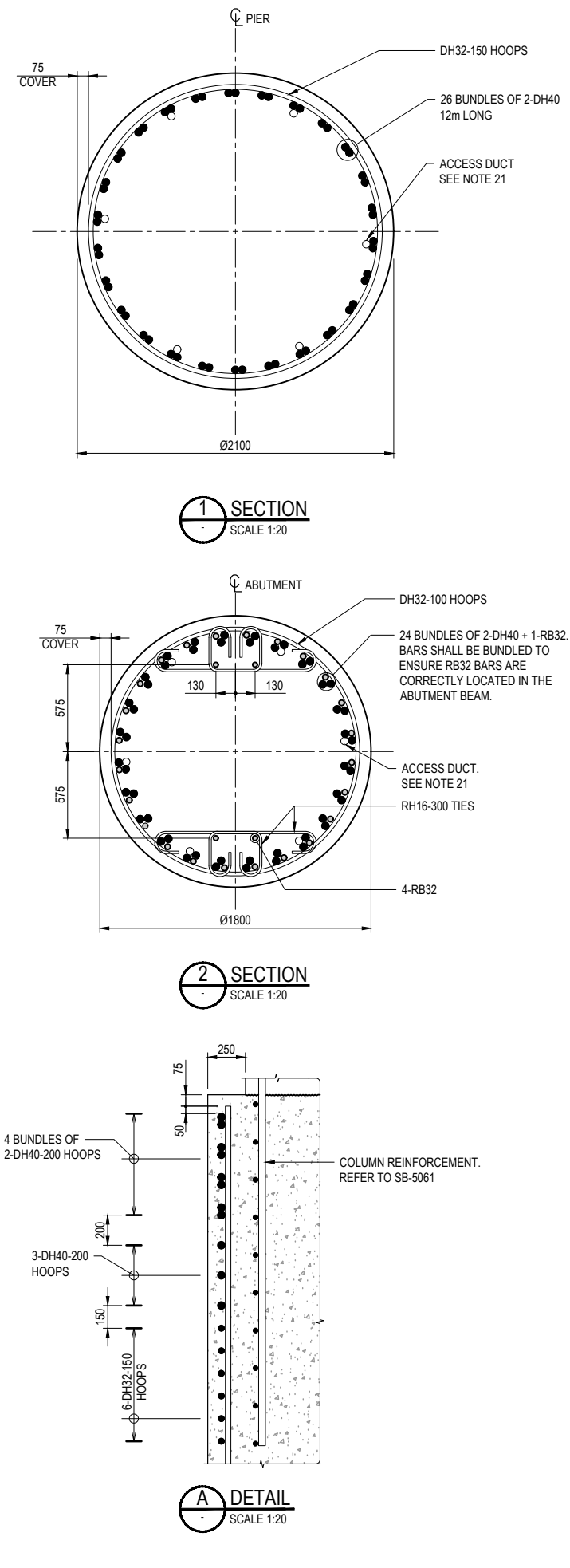
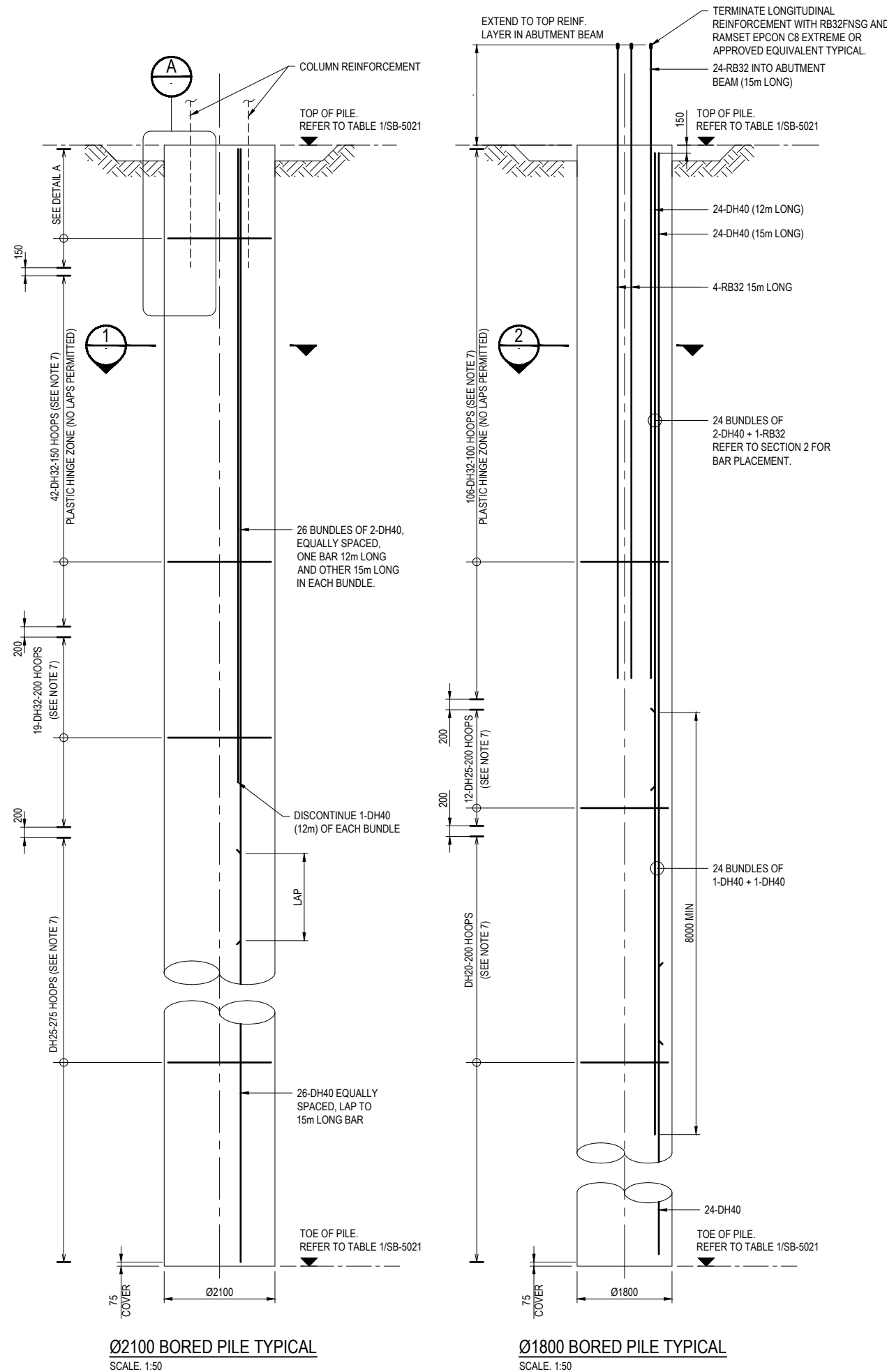

**NOTES:**

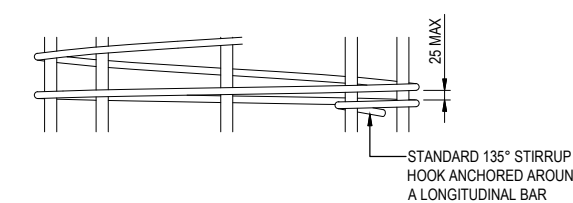
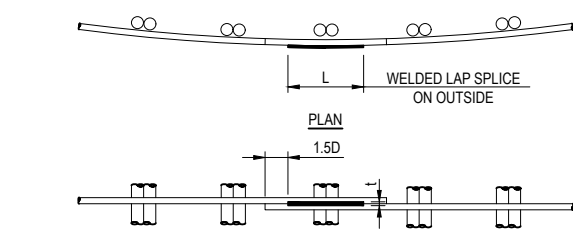
- REFER TO PP20-DR-SA-0001 TO PP20-DR-SA-0004 FOR GENERAL NOTES.
- REFER TO PP20-DR-SB-5001 FOR BRIDGE SPECIFIC NOTES.
- THIS DRAWING SHALL BE READ IN CONJUNCTION WITH SB-5021.
- THE CONCRETE FOR BORED PILES SHALL BE GRADE 40 MPa UNO IN ACCORDANCE WITH TABLE C0600.1 OF TECHNICAL SPECIFICATION C0600.
- ALL REINFORCEMENT SHALL BE G500E TO AS/NZS4671.
- HOOPS SHALL BE WELDED IN ACCORDANCE WITH AS/NZS1554. HOOP SPLICES SHALL BE STAGGERED IN PLAN.
- REINFORCEMENT ANCHORAGE AND LAP SPLICES OF TRANSVERSE REINFORCEMENT.
  - FOR BAR DIAMETER  $\leq 20$ mm: UNLESS NOTED OTHERWISE ON THE STRUCTURAL DRAWINGS, ALL SPIRAL REINFORCEMENT SHALL BE ANCHORED AT BOTH FREE ENDS BY THE FOLLOWING MEANS: BY ANCHORING THE SPIRAL STIRRUP WITH A STANDARD 135° STIRRUP HOOK WHICH IS ANCHORED AROUND A LONGITUDINAL BAR. THE STIRRUP HOOK SHALL BE LOCATED WITHIN A CLEAR DISTANCE OF 25mm OR LESS FROM THE PREVIOUS SPIRAL TURN.
 
  - FOR BAR DIAMETER  $> 20$ mm: SPLICING OF THIS INDIVIDUAL HOOP REINFORCEMENT IS REQUIRED, THE INDIVIDUAL HOOP SHALL BE LAP SPLICED BY WELDS AS SHOWN BELOW.
 

| HOOP SIZE | WELD LENGTH L (mm) | WELD THICKNESS t (mm) | MIN. THROAT THICKNESS (mm) |
|-----------|--------------------|-----------------------|----------------------------|
| Ø25       | 350                | 8                     | 6.5                        |
| Ø32       | 450                | 10                    | 8                          |
| Ø40       | 500                | 14                    | 10                         |

- PILES SHALL BE CONSTRUCTED IN ACCORDANCE WITH THE TECHNICAL SPECIFICATION C0501 "BORED PILES".
- ALL TOLERANCE SHALL BE IN ACCORDANCE WITH NZS 3109:1997.
- TOPS OF PILES SHALL NOT VARY MORE THAN 75mm HORIZONTALLY AND 25mm VERTICALLY FROM THEIR TRUE POSITION AS INDICATED ON THE DRAWINGS
- THE MAXIMUM PERMITTED DEVIATION OF PILES FROM VERTICAL AT ANY LEVEL SHALL NOT BE MORE THAN 1.75.
- PROOF BORES SHALL BE CARRIED OUT AND DESIGN PILE TOE LEVELS SHALL BE CONFIRMED BY THE DESIGNER BASED ON DRILLING RECORDS. THESE WILL BE GIVEN IN THE PILE TOE TABLE 1/SB-5021.
- FINAL TOE LEVELS SHALL BE CONFIRMED ON SITE BY DESIGNER SUBJECT TO MATERIALS ENCOUNTERED DURING DRILLING.
- PILES SHALL BE CONSTRUCTED IN ACCORDANCE WITH THE PILE CONSTRUCTION METHODOLOGY ACCEPTED BY THE DESIGNER. OTHER METHODS OF CONSTRUCTION ARE NOT PERMITTED. THE DESIGN ASSUMES:
  - FULLY ASSEMBLED COLUMN CAGE WILL BE PLUNGED INTO WET CONCRETE OF PILE TOP, TO AVOID LAPPING OF COLUMN BARS AND 2ND STAGE CONCRETING OF PILE-COLUMN INTERFACE.
  - THE PILE WALLS SHALL BE CLEANED AND ROUGHENED TO REMOVE ALL MECHANICALLY SOFTENED MATERIALS RESULTING FROM ITS DRILLING PROCESS.
  - THE BASE OF PILE SHALL BE CLEANED TO ENSURE THAT ALL SOFT MATERIAL, BROKEN PIECES AND LOOSE MATERIALS ARE REMOVED FROM THE BASE BEFORE LOWERING THE REINFORCEMENT CAGE.
  - PLACEMENT OF REINFORCEMENT SHALL FOLLOW IMMEDIATELY AFTER THE DESIGNER'S APPROVAL OF FOUNDED CONDITION.
  - PILE CONCRETE SHALL BE PLACED BY TREMIE CONCRETE METHOD, AS SPECIFIED IN THE TECHNICAL SPECIFICATION C0601 "REINFORCED CONCRETE SUPPLY".
  - REMOVE THE OVERCAST CONCRETE, WITHOUT DISTURBING OR DAMAGING THE REINFORCEMENT AND ENSURE ALL LAITANCE IS REMOVED.
  - SONIC LOGGING TUBES SHALL BE INSTALLED AND PILES TESTED FOR INTEGRITY IN ACCORDANCE WITH THE SPECIFICATIONS.
  - ALL WELDS SHALL BE SP WELD AND SHALL BE VISUALLY EXAMINED BY A SUITABLY QUALIFIED AND EXPERIENCED WELDING INSPECTOR.
  - FOR THE EXTENT OF NON-DESTRUCTIVE WELD TESTING, REFER TO TABLE C0601.1 OF TECHNICAL SPECIFICATION C0601.
  - 6 No. 40 to 50mm ID MILD STEEL (NON-GALVANISED) ACCESS DUCTS EQUALLY SPACED AROUND DIAMETER OF PILE AS SHOWN (CROSS HOLE SONIC LOGGING TUBES FOR INTEGRITY TESTING) IN ACCORDANCE WITH ASTM D6760-14:
    - DUCTS SHALL BE CLOSE ENDED AT BOTTOM AND FITTED WITH REMOVABLE END CAPS AT TOP.
    - FILL DUCTS WITH WATER PRIOR TO CONCRETING.
    - PROVIDE 200mm COVER TO BASE OF PILE. TOP OF DUCTS SHALL BE KEPT FREE FROM OBSTRUCTIONS WHICH COULD PREVENT ACCESS FOR TESTING. EXTEND TOP OF DUCTS TO A MAXIMUM OF 500mm PAST THE TOP OF PILE OR 100mm PAST THE LONGITUDINAL REINFORCEMENT TO ALLOW ACCESS FOR TESTING.
    - THE TOPS OF ALL DUCTS IN A PILE SHALL BE AT THE SAME LEVEL.

**FOR CONSTRUCTION**

| No. | Revision         | By  | Chk | Appd | Date     |
|-----|------------------|-----|-----|------|----------|
| 1   | FOR CONSTRUCTION | CRB | LZC | JK   | 07.02.18 |

| Scale (A1) | Design       | L.CHEN  | 08.05.17 | Approved For Construction |
|------------|--------------|---------|----------|---------------------------|
| AS SHOWN   | Drawn        | C.BURKE | 17.02.17 | B.SYMMANS                 |
| Scale (A3) | Design Check | G.BROWN | 15.05.17 |                           |
|            | Design Check | B.FLYNN | 22.05.17 | Date 07.02.18             |

\* Refer to Original Hardcopy for Signature

NZ TRANSPORT AGENCY WAIKATOHA

Peka Peka to Ōtaki Expressway

Fletcher HIGGINS

BECA

Tonkin+Taylor

|          |                               |              |                 |
|----------|-------------------------------|--------------|-----------------|
| Subject: | ŌTAKI RIVER BRIDGE (BRIDGE 5) | Discipline:  | STRUCTURAL      |
| Title:   | BORED PILE DETAILS            | Drawing No.: | PP20-DR-SB-5022 |
|          |                               | Rev.:        | 1               |

**NOTES:**

1. REFER TO PP20-DR-SA-0001 TO PP20-DR-SA-0004 FOR GENERAL NOTES.
2. REFER TO PP20-DR-SB-5001 FOR BRIDGE SPECIFIC NOTES.
3. REFER TO PP20-DR-SB-5083 FOR NOMINAL BEARING HEIGHTS, BEARING HEIGHT SHALL BE CONFIRMED WITH BEARING SUPPLIER.

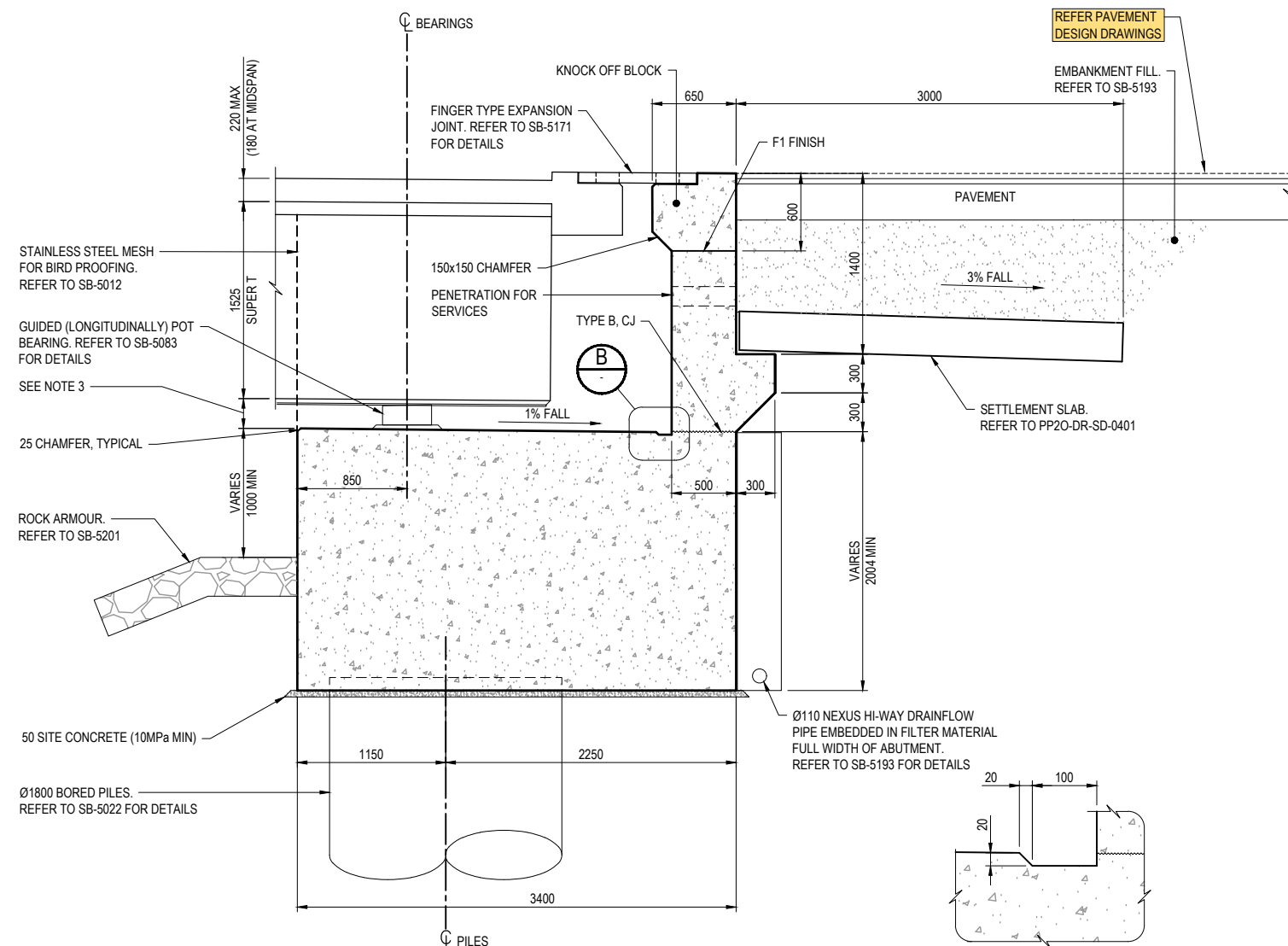

**1 SECTION**  
SB-5031 SCALE 1:25

**B DETAIL**  
SCALE 1:5

**2 SECTION**  
SB-5031 SCALE 1:25

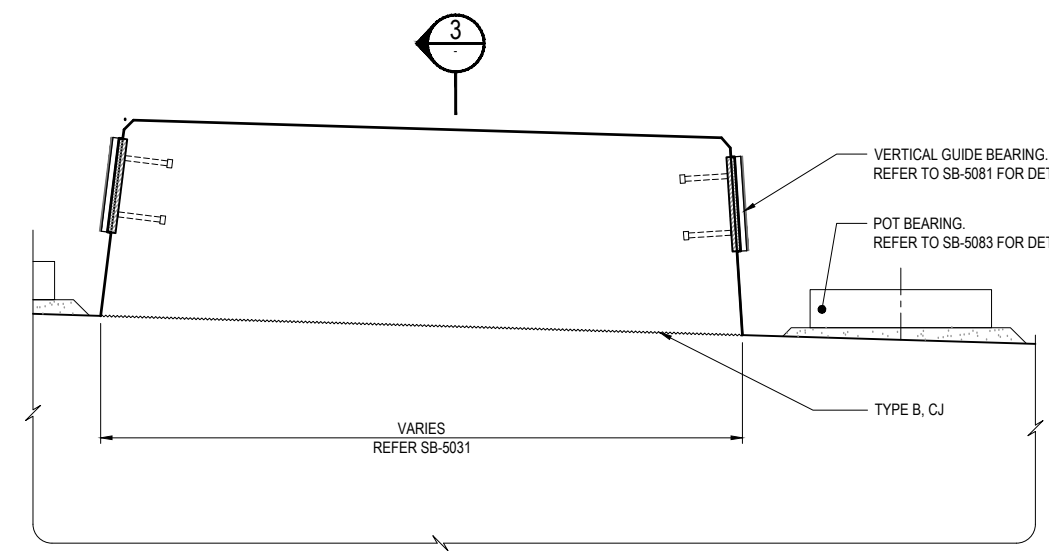

**A DETAIL - SHEAR KEY**  
SB-5031 SCALE 1:10

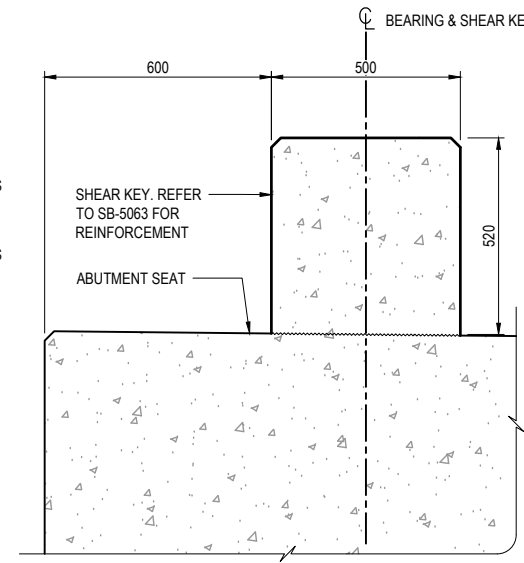

**3 SECTION**  
SCALE 1:10

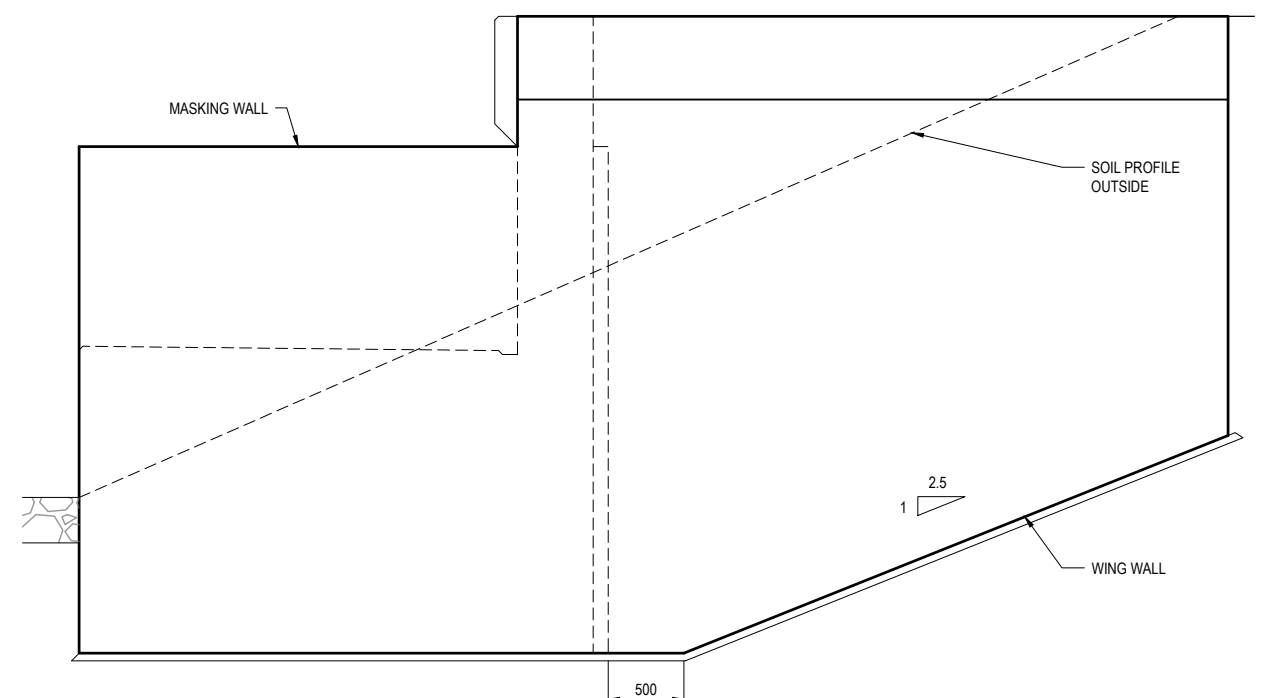

**3 SECTION**  
SB-5031 SCALE 1:25

**FOR CONSTRUCTION**

| No. | Revision         | By  | Chk | Appd | Date     |
|-----|------------------|-----|-----|------|----------|
| 1   | FOR CONSTRUCTION | CRB | LZC | JK   | 07.02.18 |

| Scale (A1) | Design       | L.CHEN  | 17.02.17 | Approved For Construction |
|------------|--------------|---------|----------|---------------------------|
| AS SHOWN   | Drawn        | C.BURKE | 07.02.17 | B.SYMMANS                 |
| Scale (A3) | Design Check | G.BROWN | 15.05.17 |                           |
|            | Design Check | B.FLYNN | 22.05.17 | Date 07.02.18             |

\* Refer to Original Hardcopy for Signature

NZ TRANSPORT AGENCY  
Peka Peka to Ōtaki Expressway  
Fletcher HIGGINS  
BECA  
Tonkin+Taylor

|          |                               |              |                 |
|----------|-------------------------------|--------------|-----------------|
| Subject: | ŌTAKI RIVER BRIDGE (BRIDGE 5) | Discipline:  | STRUCTURAL      |
| Title:   | ABUTMENT CONCRETE SHEET 2     | Drawing No.: | PP20-DR-SB-5032 |

|      |   |
|------|---|
| Rev. | 1 |
|------|---|

**NOTES:**

1. REFER TO PP20-DR-SA-0001 TO PP20-DR-SA-0004 FOR GENERAL NOTES.
2. REFER TO PP20-DR-SB-5001 FOR BRIDGE SPECIFIC NOTES.
3. REFER TO RELEVANT CIVIL DRAWINGS FOR LOCATION OF UTILITIES AND SERVICES.
4. REFER BULK EARTHWORKS SPECIFICATION FOR FILL, PLACEMENT, COMPACTION AND TESTING REQUIREMENTS.

**LEGEND:**

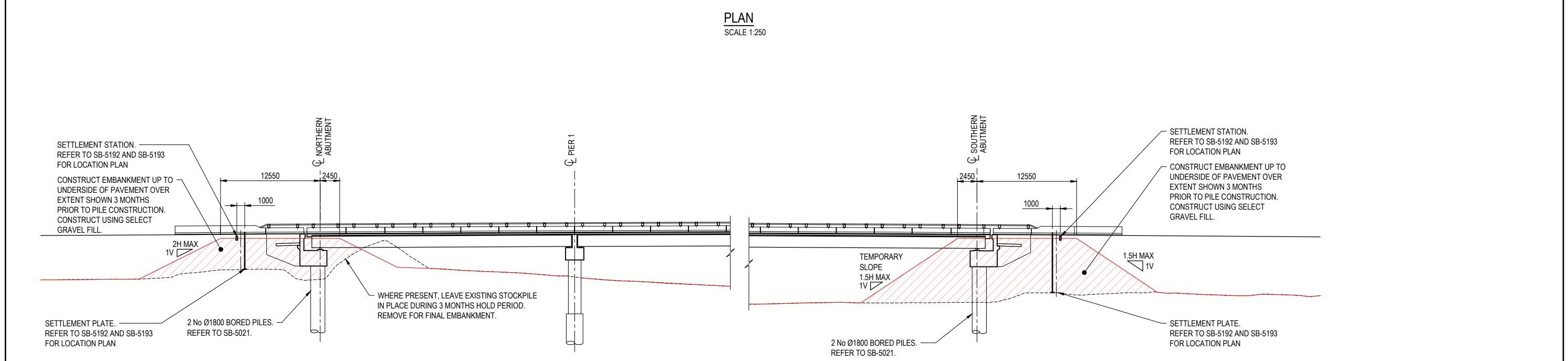
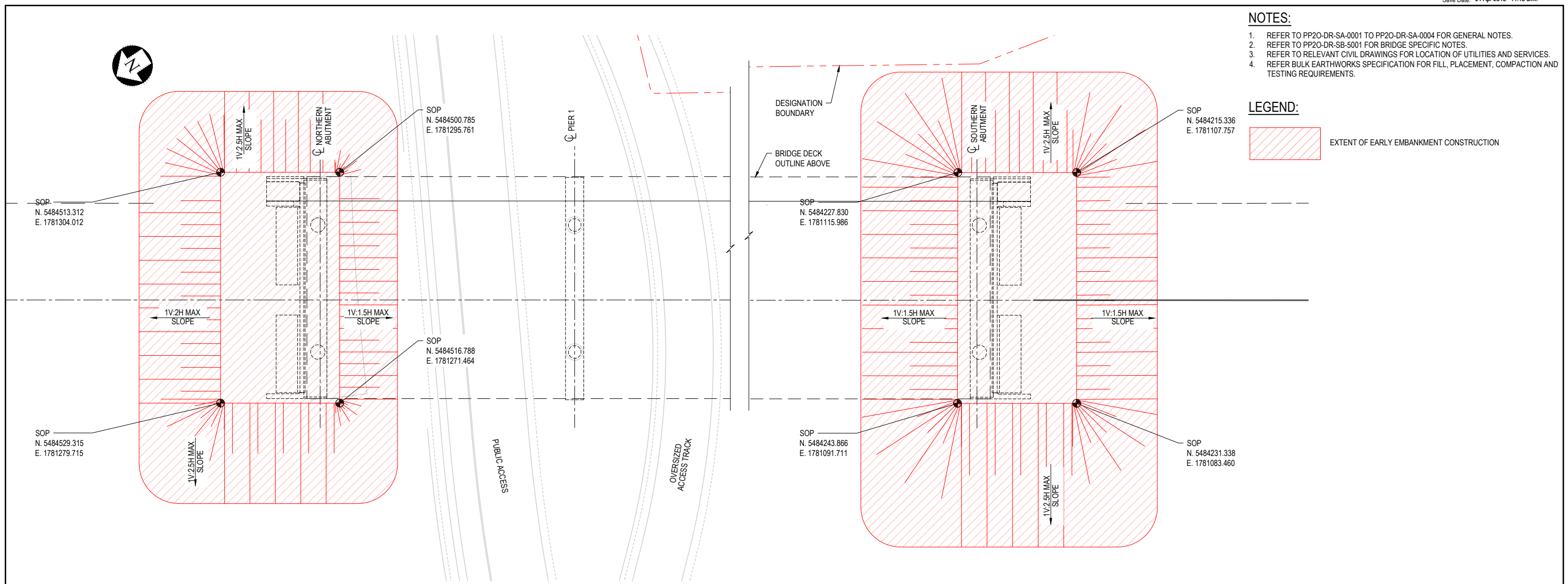
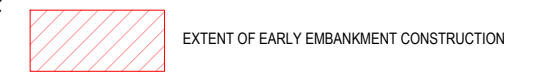

**FOR CONSTRUCTION**

|     |                  |     |     |      |          |
|-----|------------------|-----|-----|------|----------|
| No. | Revision         | By  | Chk | Appd | Date     |
| 1   | FOR CONSTRUCTION | CRB | LZC | JK   | 04.04.18 |

|              |           |          |                           |
|--------------|-----------|----------|---------------------------|
| Design       | L.CHEN    | 08.05.17 | Approved For Construction |
| Drawn        | D.PILIANG | 08.05.17 |                           |
| Dwg Verifier | G.BROWN   | 15.05.17 |                           |
| Dwg Check    | B.FLYNN   | 22.05.17 | Date                      |

Scale (A1) AS SHOWN  
Scale (A3)

\* Refer to Original Hardcopy for Signature

**NZ TRANSPORT AGENCY** WAIKAŌTIRI

**Peka Peka to Ōtaki Expressway**

**Fletcher HIGGINS**

**BECA** **TFT** **Tonkin+Taylor**

|          |                               |              |                 |
|----------|-------------------------------|--------------|-----------------|
| Subject: | ŌTAKI RIVER BRIDGE (BRIDGE 5) | Discipline:  | STRUCTURAL      |
| Title:   | EARLY EMBANKMENT CONSTRUCTION | Drawing No.: | PP20-DR-SB-5191 |
|          |                               | Rev.:        | 1               |

**NOTES:**

1. REFER TO PP20-DR-SA-0001 TO PP20-DR-SA-0004 FOR GENERAL NOTES.
2. REFER TO PP20-DR-SB-5001 FOR BRIDGE SPECIFIC NOTES.
3. REFER TO RELEVANT CIVIL DRAWINGS FOR LOCATION OF UTILITIES AND SERVICES.
4. REFER TO CIVIL DRAWINGS FOR ROCK ARMOUR AND ABUTMENT FILL DETAILS.
5. REFER GEOTECHNICAL INSTRUMENTATION AND MONITORING PLAN FOR REQUIREMENTS.

**SETTLEMENT MONITORING LEGEND:**

- 3D REFLECTIVE MARKERS ▲
- SETTLEMENT PLATES (AT BASE UNDERCUT) WITH PLASTIC SLEEVE THROUGH EMBANKMENT ◻
- SETTLEMENT STATION (AT TOP OF EMBANKMENT) INITIALLY CONSTRUCT AT TOP OF EARLY EMBANKMENT. RELOCATE TO TOP OF FINAL EMBANKMENT WHEN CONSTRUCTED ○
- REFER PP20-DR-GE-0131 AND 0132 FOR TYPICAL DETAILS

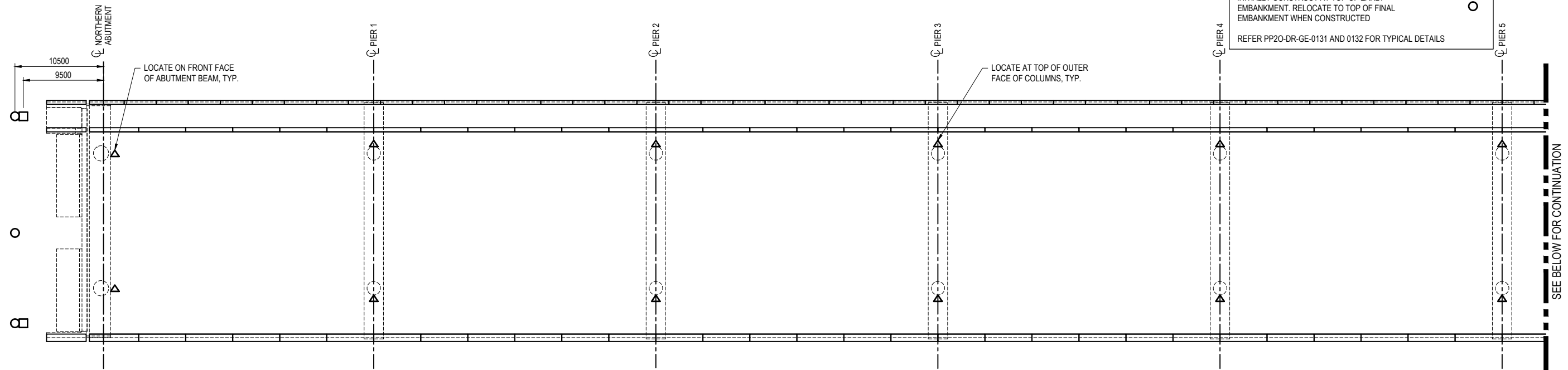

**SETTLEMENT INSTRUMENTATION PLAN**  
SCALE 1:250

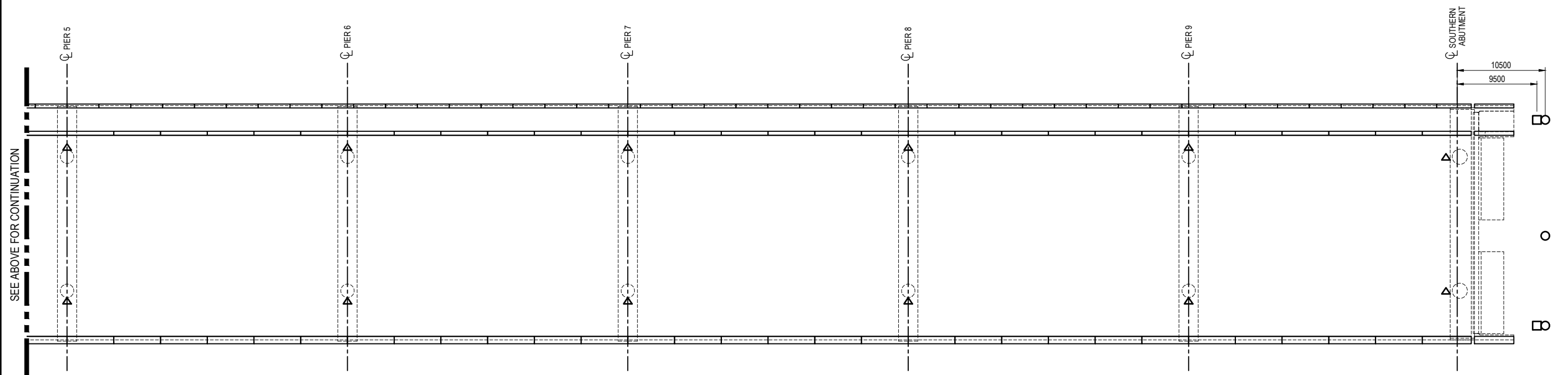

**SETTLEMENT INSTRUMENTATION PLAN CONT.**  
SCALE 1:250

**FOR CONSTRUCTION**

| No. | Revision         | By  | Chk | Appd | Date     |
|-----|------------------|-----|-----|------|----------|
| 1   | FOR CONSTRUCTION | CRB | LZC | JK   | 04.04.18 |

| Scale (A1) AS SHOWN | Design | Drawn     | Dwg Verifier | Dwg Check | Date     | Approved For Construction |
|---------------------|--------|-----------|--------------|-----------|----------|---------------------------|
| Scale (A3)          | L.CHEN | D.PILIANG | G.BROWN      | B.FLYNN   | 08.05.17 | 08.05.17                  |
|                     |        |           |              |           | 15.05.17 |                           |
|                     |        |           |              |           | 22.05.17 |                           |

\* Refer to Original Hardcopy for Signature

**Peka Peka to Ōtaki Expressway**

|          |   |              |                 |
|----------|---|--------------|-----------------|
| Subject: | ŌTAKI RIVER BRIDGE (BRIDGE 5)             | Discipline:  | STRUCTURAL      |
| Title:   | SETTLEMENT INSTRUMENTATION AND MONITORING | Drawing No.: | PP20-DR-SB-5192 |

|      |   |
|------|---|
| Rev. | 1 |
|------|---|

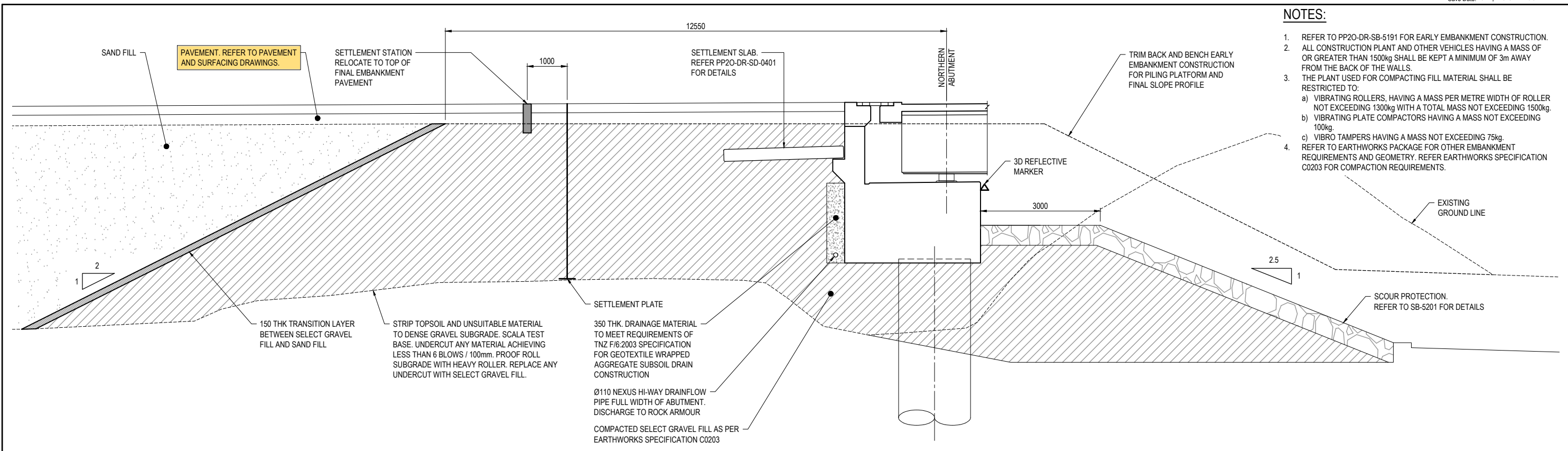

SECTION OF NORTHERN ABUTMENT BACKFILL  
SCALE 1:50

- NOTES:**
- REFER TO PP20-DR-SB-5191 FOR EARLY EMBANKMENT CONSTRUCTION.
  - ALL CONSTRUCTION PLANT AND OTHER VEHICLES HAVING A MASS OF OR GREATER THAN 1500kg SHALL BE KEPT A MINIMUM OF 3m AWAY FROM THE BACK OF THE WALLS.
  - THE PLANT USED FOR COMPACTING FILL MATERIAL SHALL BE RESTRICTED TO:
    - VIBRATING ROLLERS, HAVING A MASS PER METRE WIDTH OF ROLLER NOT EXCEEDING 1300kg WITH A TOTAL MASS NOT EXCEEDING 1500kg.
    - VIBRATING PLATE COMPACTORS HAVING A MASS NOT EXCEEDING 100kg.
    - VIBRO TAMPERS HAVING A MASS NOT EXCEEDING 75kg.
  - REFER TO EARTHWORKS PACKAGE FOR OTHER EMBANKMENT REQUIREMENTS AND GEOMETRY. REFER EARTHWORKS SPECIFICATION C0203 FOR COMPACTION REQUIREMENTS.

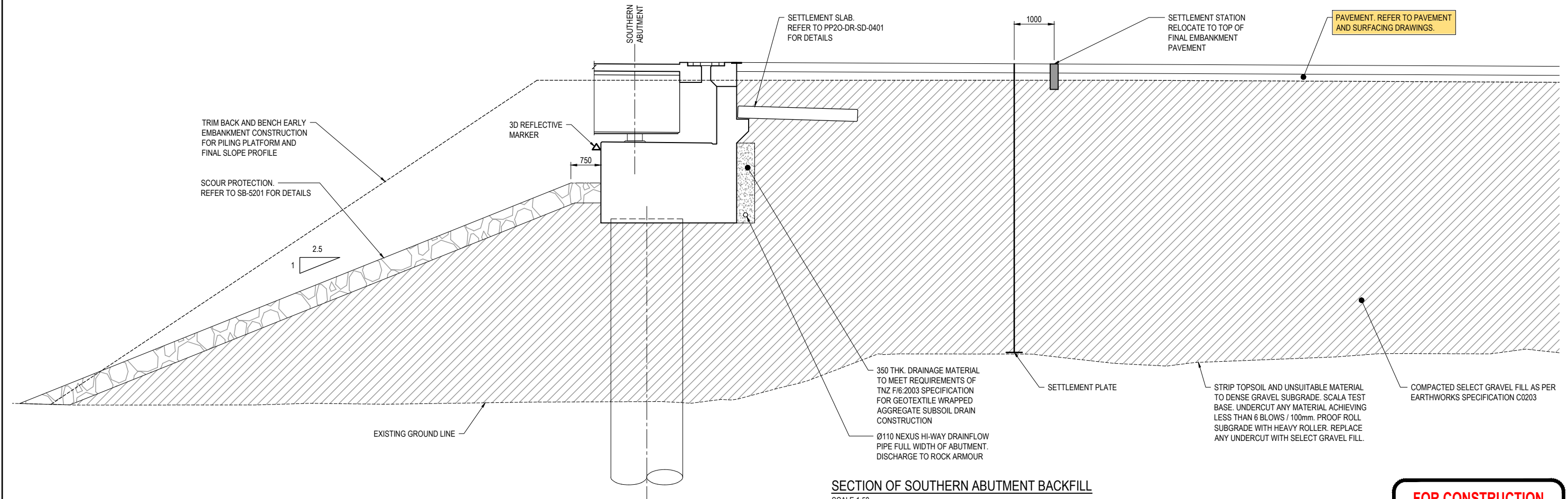

SECTION OF SOUTHERN ABUTMENT BACKFILL  
SCALE 1:50

**FOR CONSTRUCTION**

| No. | Revision         | By  | Chk | Appd | Date     |
|-----|------------------|-----|-----|------|----------|
| 1   | FOR CONSTRUCTION | CRB | LZC | JK   | 04.04.18 |

| Scale (A1) | Design       | L. CHEN    | 08.05.17 | Approved For Construction |
|------------|--------------|------------|----------|---------------------------|
| AS SHOWN   | Drawn        | D. PILIANG | 08.05.17 |                           |
| Scale (A3) | Design Check | G. BROWN   | 15.05.17 |                           |
|            | Design Check | B. FLYNN   | 22.05.17 | Date                      |

\* Refer to Original Hardcopy for Signature

|          |                                      |              |                 |
|----------|--------------------------------------|--------------|-----------------|
| Subject: | ŌTAKI RIVER BRIDGE (BRIDGE 5)        | Discipline:  | STRUCTURAL      |
| Title:   | EARTHWORKS, BACKFILLING AND DRAINAGE | Drawing No.: | PP20-DR-SB-5193 |

|      |   |
|------|---|
| Rev. | 1 |
|------|---|

**NOTES:**

1. REFER TO PP20-DR-SA-0001 TO PP20-DR-SA-004 FOR GENERAL NOTES.
2. REFER TO PP20-DR-SB-5001 FOR BRIDGE SPECIFIC DRAWINGS.
3. ROCK ARMOUR SHALL BE UNWEATHERED, HARD AND ANGULAR QUARRIED ROCK.
4. ROCK ARMOUR SHALL BE CONSTRUCTED IN ACCORDANCE WITH TECHNICAL SPECIFICATION C0226 "ROCK ARMOUR".

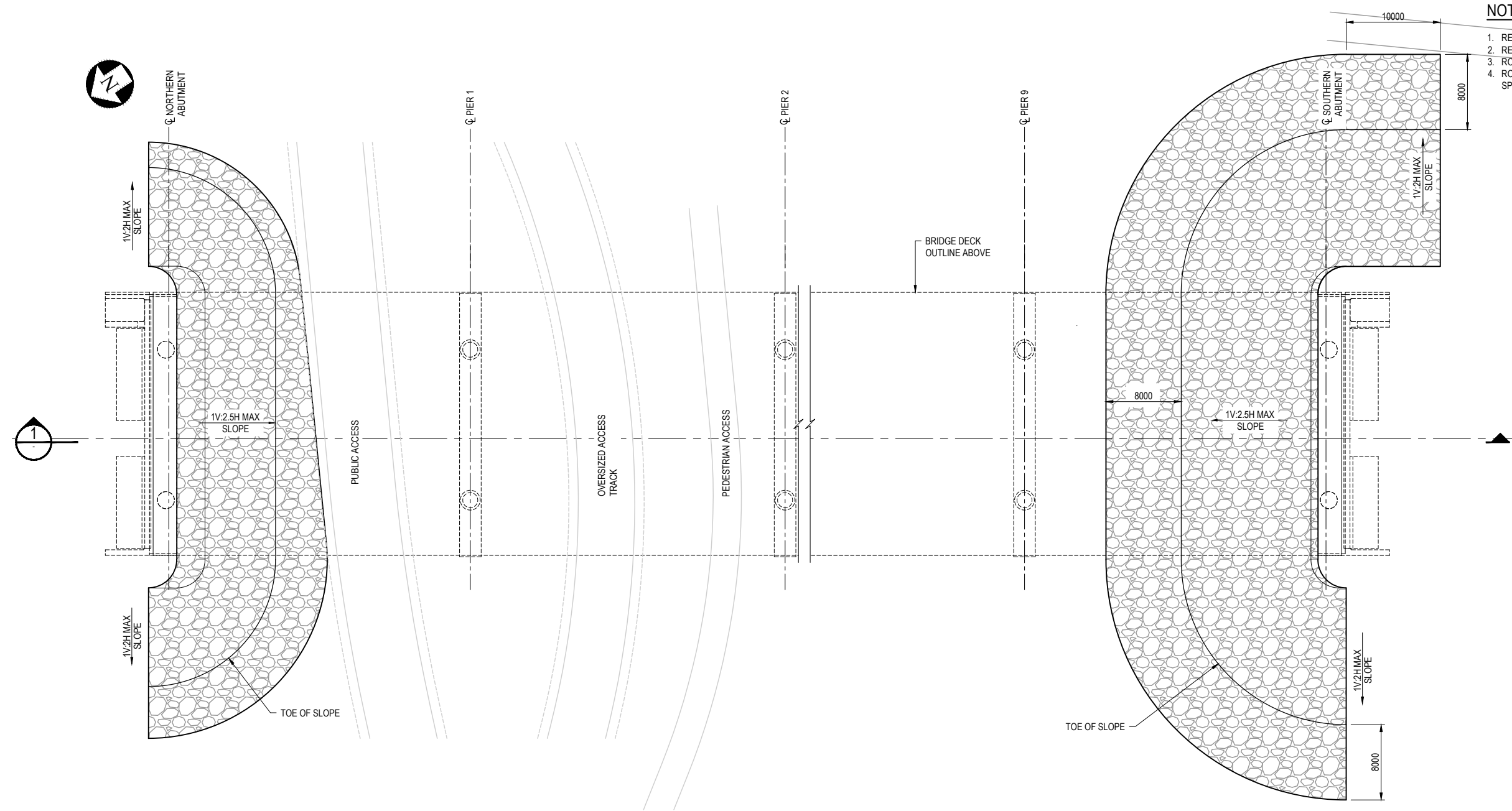

**PLAN**  
SCALE 1:250

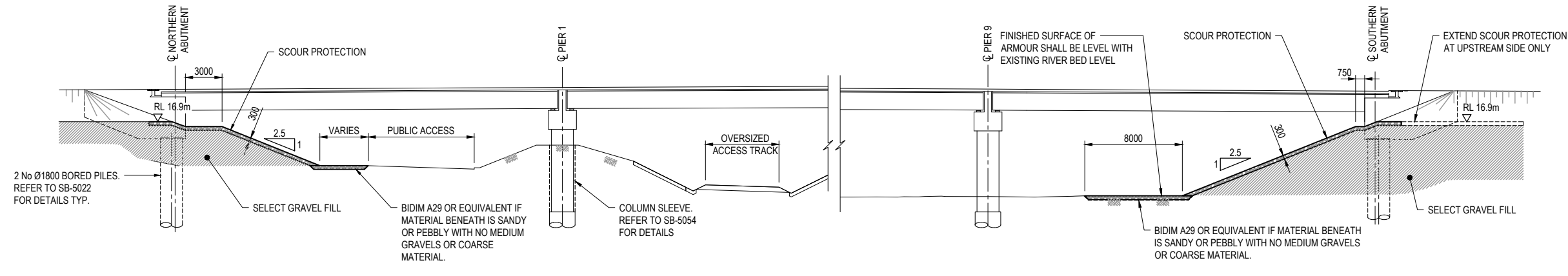

**SECTION**  
SCALE 1:200

**TABLE 1. ABUTMENT ROCK GRADATION**

| GRADE     | ROCK SIZE (mm) |
|-----------|----------------|
| $d_{max}$ | 300            |
| $d_{50}$  | 150 TO 200     |
| $d_{15}$  | 80 TO 110      |

**FOR CONSTRUCTION**

| No. | Revision         | By  | Chk | Appd | Date     |
|-----|------------------|-----|-----|------|----------|
| 1   | FOR CONSTRUCTION | CRB | LZC | JK   | 04.04.18 |

| Scale (A1) | Design         | Date      | Approved For Construction |
|------------|----------------|-----------|---------------------------|
| AS SHOWN   | D.LEONG        | 08.05.17  |                           |
| Scale (A3) | Drawn          | D.PILIANG | 08.05.17                  |
|            | Design Checker | T.BASSETT | 15.05.17                  |
|            | Design Checker | B.FLYNN   | 22.05.17                  |

\* Refer to Original Hardcopy for Signature

**NZ TRANSPORT AGENCY** WAIKATO REGION

**Peka Peka to Ōtaki Expressway**

**Fletcher HIGGINS**

**BECA** **Tonkin+Taylor**

|          |                               |              |                 |
|----------|-------------------------------|--------------|-----------------|
| Subject: | ŌTAKI RIVER BRIDGE (BRIDGE 5) | Discipline:  | STRUCTURAL      |
| Title:   | SCOUR PROTECTION DETAILS      | Drawing No.: | PP20-DR-SB-5201 |
|          |                               | Rev.:        | 1               |



**DATUM NOTES**  
 COORDINATE DATUM: NZ TRANSVERSE MERCATOR (NZTM)  
 HEIGHT DATUM: NZVD 2009

- PROJECT SET OUT USING ELECTRONIC INFORMATION FROM MODELS PROVIDED, UNLESS OTHERWISE NOTED.
- INFORMATION ON DRAWINGS TAKES PRECEDENCE.
- ANY DISCREPANCIES SHALL BE BROUGHT TO THE ATTENTION OF THE DESIGNER.

**LEGEND:**  
 EXPRESSWAY ————  
 LOCAL ROADS ————  
 N.I.M.T RAIL REALIGNMENT ————

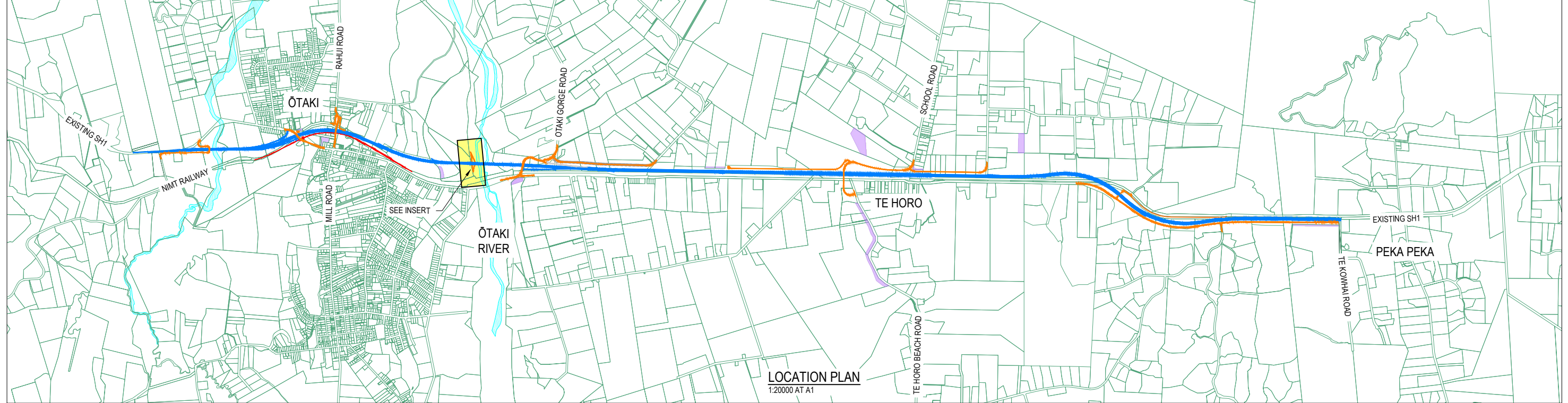

**DRAWING LIST**

| Sheet Number                                 | Description   |
|--|---|
| <b>Civil Local Roads; Quarry Access Road</b> |   |
| <b>General Arrangements</b>                  |   |
| PP20-DR-CL-0400                              | Cover Sheet   |
| PP20-DR-CL-0401                              | General Arrangement - Layout Plan Sheet                                     |
| <b>Plan and Longitudinal Sections</b>        |   |
| PP20-DR-CL-0410                              | Public Access Plan and longitudinal section - Alignment String MCF0         |
| PP20-DR-CL-0411                              | Over Dimension Access Plan and longitudinal section - Alignment String MCF1 |
| PP20-DR-CL-0412                              | Shared Path Plan and longitudinal section - Alignment String MCX3           |
| PP20-DR-CL-0413                              | Shared Path Plan and longitudinal section - Alignment String MCX5           |
| <b>Detail Plans</b>                          |   |
| PP20-DR-CL-0420                              | Detailed Layout Plan  |
| <b>Typical Cross Sections</b>                |   |
| PP20-DR-CL-0450                              | Typical Cross Sections  |
| <b>20m Interval Cross Sections</b>           |   |
| PP20-SK-CL-0460                              | 20m Interval Cross Sections - Sheet 1 of 4                                  |
| PP20-SK-CL-0461                              | 20m Interval Cross Sections - Sheet 2 of 4                                  |
| PP20-SK-CL-0462                              | 20m Interval Cross Sections - Sheet 3 of 4                                  |
| PP20-SK-CL-0463                              | 20m Interval Cross Sections - Sheet 4 of 4                                  |

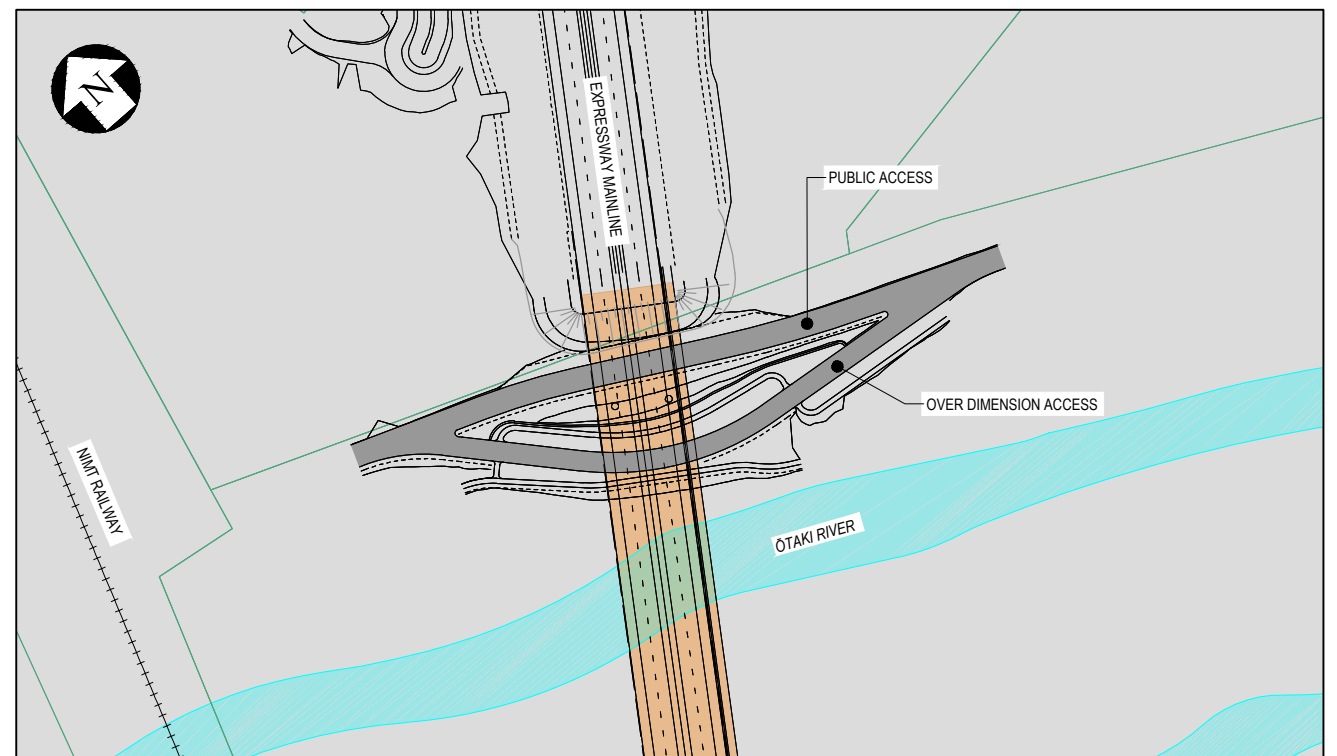

**QUARRY ACCESS ROAD**  
N.T.S.

ORIGINAL IN COLOUR

**PRELIMINARY**  
**NOT FOR CONSTRUCTION**

| No. | Revision    | By | Chk | Appd | Date     |
|-----|-------------|----|-----|------|----------|
| B   | 100% DESIGN |    |     |      | 27.07.18 |
| A   | 80% DESIGN  |    |     |      | 1.12.17  |

| Scale (A1) | Design      | Drawn  | Date     | Approved For Construction |
|------------|-------------|--------|----------|---------------------------|
| AS SHOWN   | P.Chowdhury | L.Wang | 27.07.18 | 27.07.18                  |

**NZ TRANSPORT AGENCY** **Peka Peka to Otaki Expressway** **Fletcher HIGGINS** **BECA** **Tonkin+Taylor**

|          |                    |              |                 |
|----------|--------------------|--------------|-----------------|
| Subject: | QUARRY ACCESS ROAD | Discipline:  | CIVIL           |
| Title:   | COVER SHEET        | Drawing No.: | PP20-DR-CL-0400 |

|       |   |
|-------|---|
| Rev.: | B |
|-------|---|



**LEGEND:**

- DESIGNATION BOUNDARY
- MSE WALL
- ▭ LOCAL ROAD
- ▭ PRIVATE/MAINTENANCE ACCESS
- ▭ STRUCTURE
- ▭ PATH
- EXISTING PATH
- EXISTING RAILWAY
- PROPOSED RAILWAY

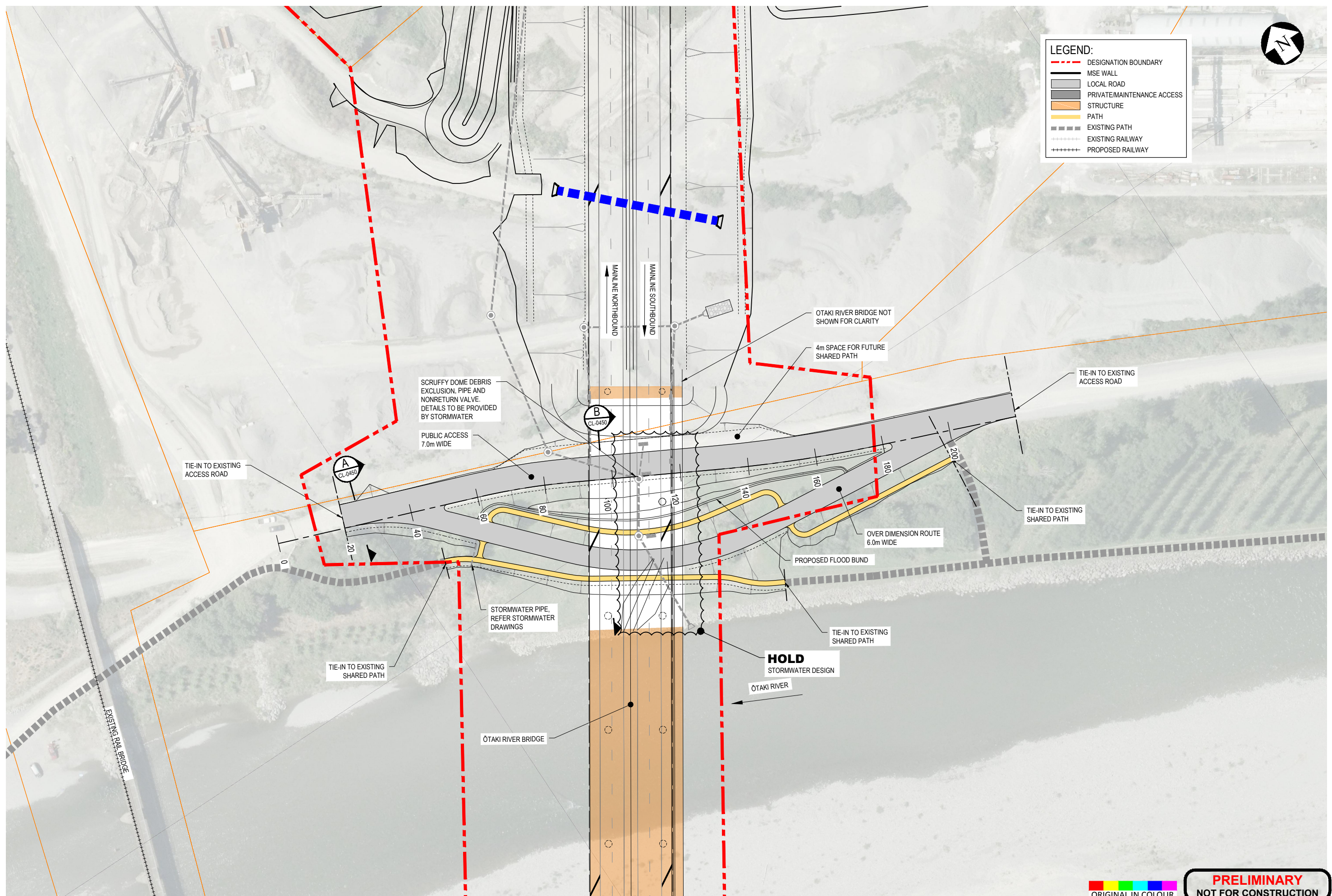

ORIGINAL IN COLOUR

**PRELIMINARY**  
**NOT FOR CONSTRUCTION**

| No. | Revision    | By  | Chk | Appd | Date     |
|-----|-------------|-----|-----|------|----------|
| B   | 100% DESIGN | PaC | DT  | SW   | 27.07.18 |
| A   | 80% DESIGN  | JL  | PC  | BS   | 01.12.17 |

| Scale (A1) | Design       | Drawn   | Date     | Approved For Construction |
|------------|--------------|---------|----------|---------------------------|
| 1:500      | P. Chowdhury | L. Wang | 27.07.18 |                           |
| Scale (A3) | Design       | Drawn   | Date     | Approved For Construction |
|            |              |         |          |                           |

\* Refer to Original Hardcopy for Signature

**Peka Peka to Otaki Expressway**

|          |                                 |
|----------|---------------------------------|
| Subject: | QUARRY ACCESS ROAD              |
| Title:   | GENERAL ARRANGEMENT LAYOUT PLAN |

|              |                 |
|--------------|-----------------|
| Discipline:  | CIVIL           |
| Drawing No.: | PP20-DR-CL-0401 |
| Rev.:        | B               |

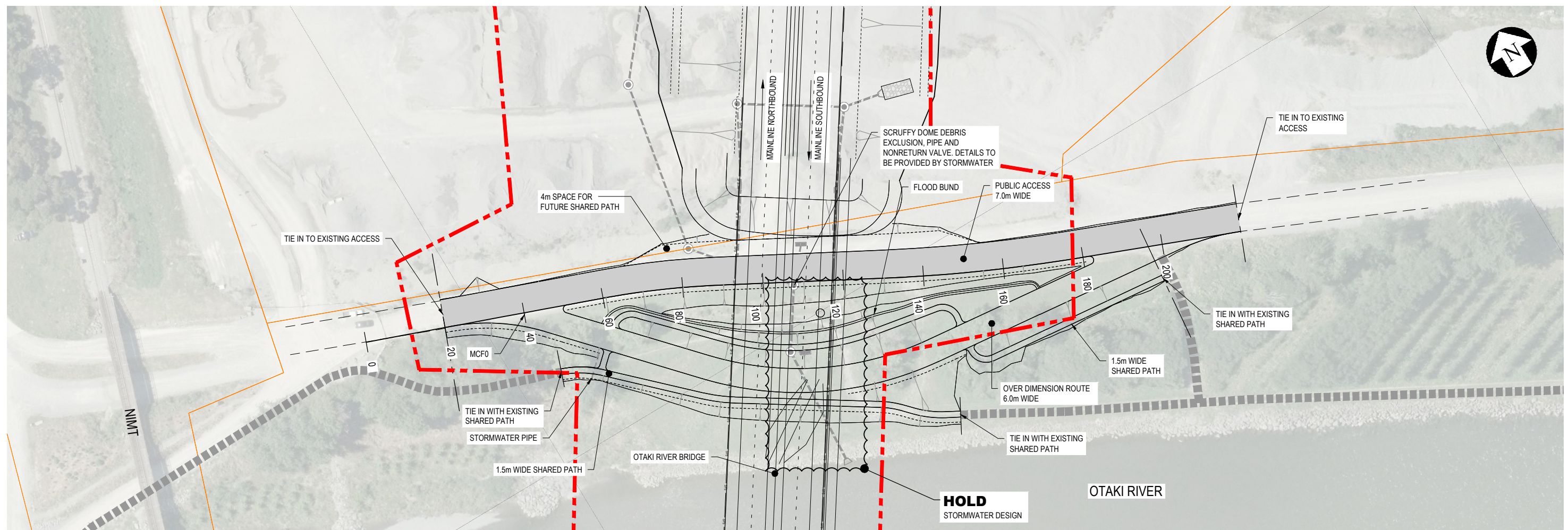

**NOTES:**

1. ALL DIMENSIONS ARE IN METRES UNLESS NOTED OTHERWISE.
2. DIGITAL TERRAIN MODEL DERIVED FROM TOPOGRAPHIC SURVEY AND LIDAR DATA PROVIDED BY THE NZ TRANSPORT AGENCY (REFER PR APPENDIX D).
3. 6.125m CLEARANCE CONSISTS OF 40mm WEARING COURSE + 25mm LEVELLING COURSE + 200mm DECK SLAB + 1525mm BEAM DEPTH + 4200mm PR CLEARANCE + 60mm BEAM DEFLECTION + 50mm CONSTRUCTION TOLERANCE + 25mm STATIC POST CONSTRUCTION TOLERANCE.

**PLAN - PUBLIC ACCESS**  
SCALE 1:500 (A1)

**LEGEND:**

- DESIGNATION BOUNDARY
- MSE WALL
- LOCAL ROAD
- PRIVATE/MAINTENANCE ACCESS
- STRUCTURE
- PATH
- EXISTING PATH
- EXISTING RAILWAY
- PROPOSED RAILWAY

**GEOMETRY LEGEND:**

- D = STRAIGHT LENGTH
- R = RADIUS
- CL = TRANSITION
- L = LENGTH
- P = GRADIENT
- K = R/100

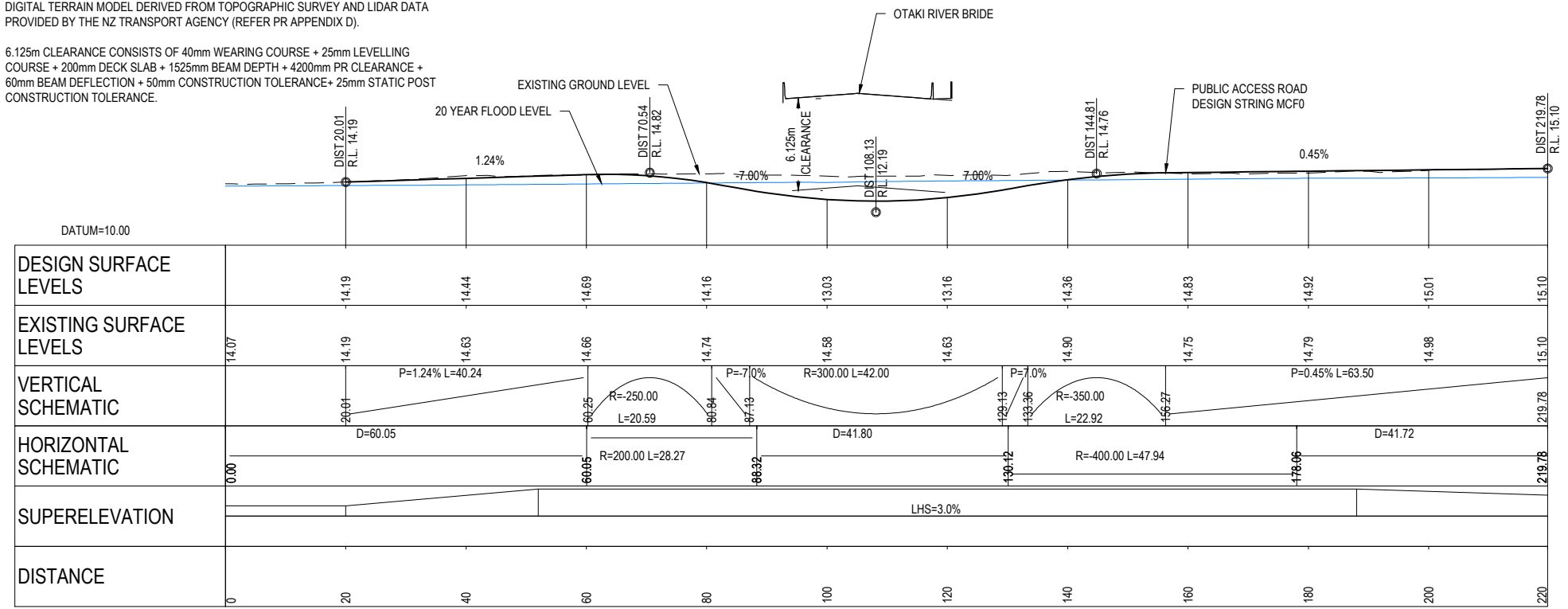

**LONGITUDINAL SECTION ON CONTROL STRING MCF0**  
SCALE HORIZ=1:500 VERT=1:200

ORIGINAL IN COLOUR  
**PRELIMINARY**  
NOT FOR CONSTRUCTION

|                        |                                    |                             |                              |
|------------------------|------------------------------------|-----------------------------|------------------------------|
| Scale (A1)<br>AS SHOWN | Design<br>P. Chowdhury<br>27.07.18 | Drawn<br>L.Wang<br>27.07.18 | Approved For<br>Construction |
| Scale (A3)             | Design<br>J.L.<br>01.11.17         | Drawn<br>P.C.<br>01.11.17   | Date                         |
| No.                    | Revision                           | By                          | Appd                         |

**NZ TRANSPORT AGENCY** WAIKATO REGION

**Peka Peka to Otaki Expressway**

**Fletcher HIGGINS**

**BECA** **Tonkin+Taylor**

|          |  |              |                 |
|----------|--|--------------|-----------------|
| Subject: | QUARRY ACCESS ROAD   | Discipline:  | CIVIL           |
| Title:   | PUBLIC ACCESS PLAN & LONGITUDINAL SECTION<br>ALIGNMENT STRING MCF0 | Drawing No.: | PP20-DR-CL-0410 |
|          |  | Rev.:        | B               |

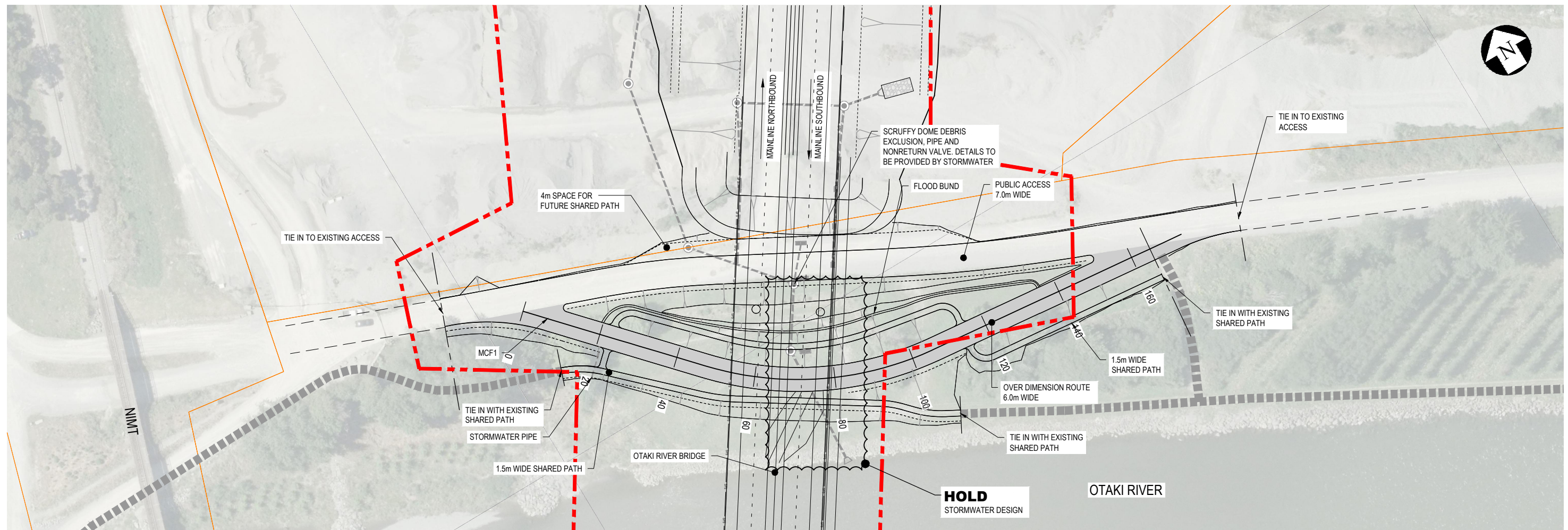

PLAN - OVER DIMENSION ACCESS  
SCALE 1:500 (A1)

**LEGEND:**

- DESIGNATION BOUNDARY
- MSE WALL
- LOCAL ROAD
- PRIVATE/MAINTENANCE ACCESS
- STRUCTURE
- PATH
- EXISTING PATH
- EXISTING RAILWAY
- PROPOSED RAILWAY

**GEOMETRY LEGEND:**

- D = STRAIGHT LENGTH
- R = RADIUS
- CL = TRANSITION
- L = LENGTH
- P = GRADIENT
- K = R/100

- NOTES:**
1. ALL DIMENSIONS ARE IN METRES UNLESS NOTED OTHERWISE.
  2. DIGITAL TERRAIN MODEL DERIVED FROM TOPOGRAPHIC SURVEY AND LIDAR DATA PROVIDED BY THE NZ TRANSPORT AGENCY (REFER PR APPENDIX D).
  3. 7.925m CLEARANCE CONSISTS OF 40mm WEARING COURSE + 25mm LEVELLING COURSE + 200mm DECK SLAB + 1525mm BEAM DEPTH + 6000mm PR CLEARANCE + 60mm BEAM DEFLECTION + 50mm CONSTRUCTION TOLERANCE + 25mm STATIC POST CONSTRUCTION TOLERANCE.

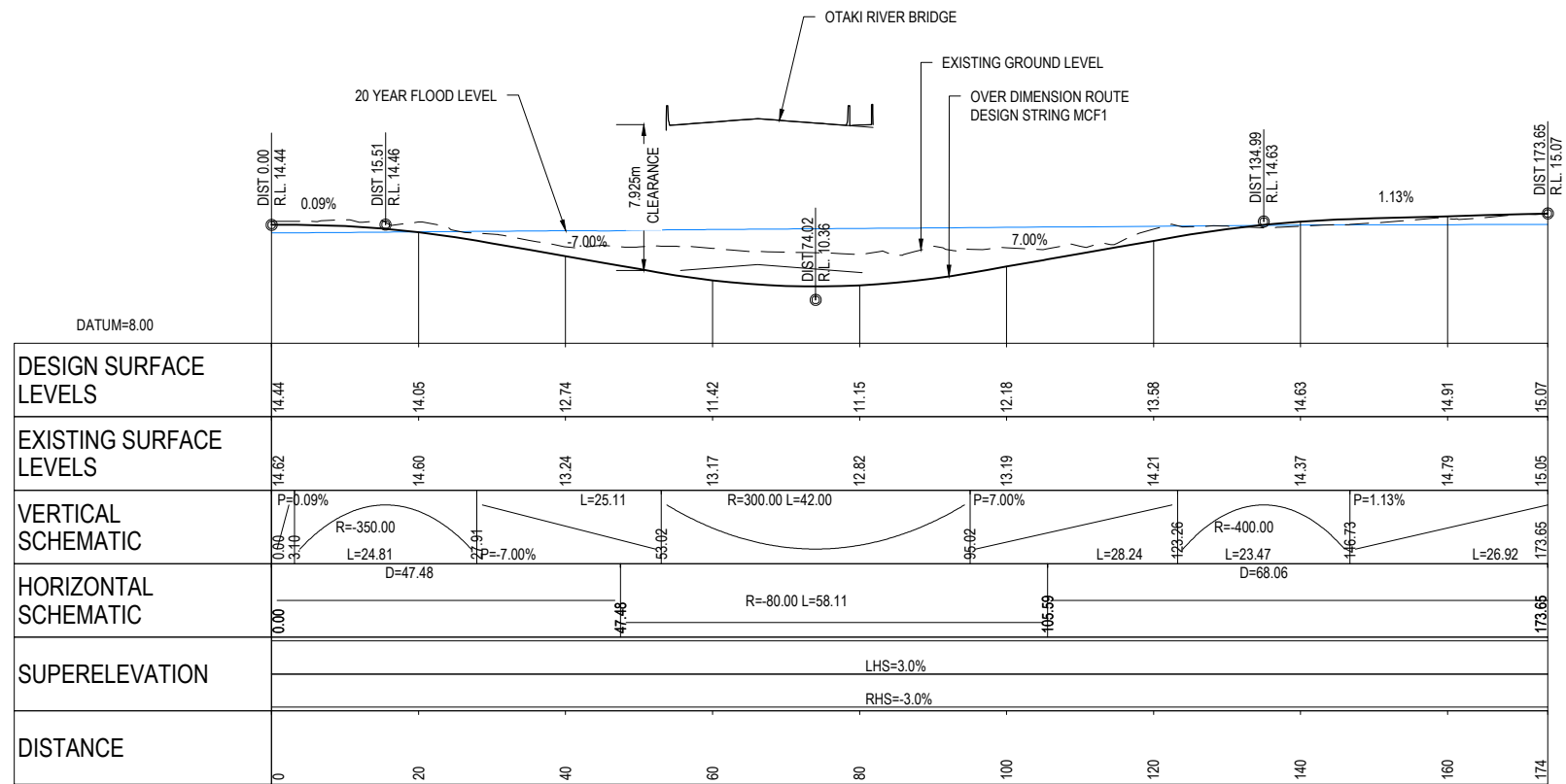

LONGITUDINAL SECTION ON CONTROL STRING MCF1  
SCALE HORIZ=1:500 VERT=1:200

ORIGINAL IN COLOUR

**PRELIMINARY**  
**NOT FOR CONSTRUCTION**

| No. | Revision    | By  | Chk | Appd | Date     |
|-----|-------------|-----|-----|------|----------|
| B   | 100% DESIGN | PgC | DT  | SW   | 27.07.18 |
| A   | 80% DESIGN  | JL  | PC  | BS   | 01.11.17 |

| Scale (A1) | Design  | P. Chowdhury | 27.07.18 | Approved For Construction |
|------------|---------|--------------|----------|---------------------------|
| AS SHOWN   | Drawn   | L.Wang       | 27.07.18 |                           |
| Scale (A3) | Design  |              |          |                           |
|            | Drawn   |              |          |                           |
|            | Checked |              |          |                           |
|            | Checked |              |          |                           |

**NZ TRANSPORT AGENCY** WAIKA TŪKURI

**Peka Peka to Ōtaki Expressway**

**Fletcher HIGGINS**

**BECA** **TFT** **Tonkin+Taylor**

|          |  |              |                 |
|----------|--|--------------|-----------------|
| Subject: | QUARRY ACCESS ROAD   | Discipline:  | CIVIL           |
| Title:   | OVER DIMENSION ACCESS PLAN & LONGITUDINAL SECTION<br>ALIGNMENT STRING MCF1 | Drawing No.: | PP20-DR-CL-0411 |
|          |  | Rev.:        | B               |

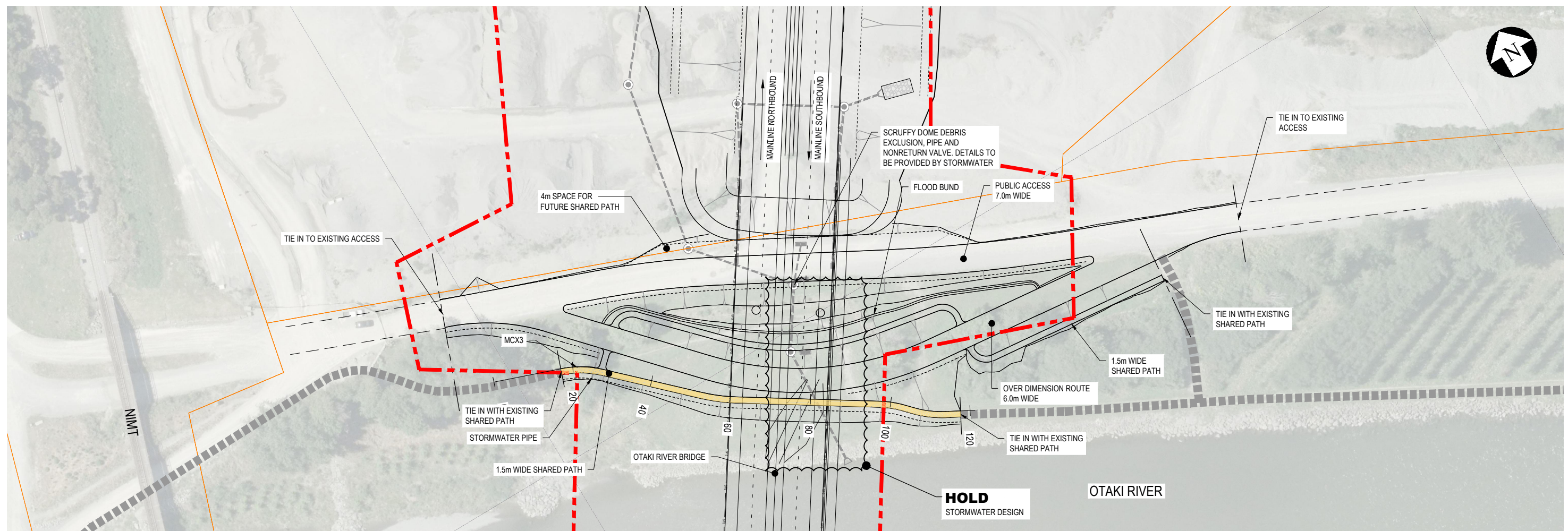

PLAN - SHARED PATH  
SCALE 1:500 (A1)

**LEGEND:**

- DESIGNATION BOUNDARY
- MSE WALL
- LOCAL ROAD
- PRIVATE/MAINTENANCE ACCESS
- STRUCTURE
- PATH
- EXISTING PATH
- EXISTING RAILWAY
- PROPOSED RAILWAY

**GEOMETRY LEGEND:**

- D = STRAIGHT LENGTH
- R = RADIUS
- CL = TRANSITION
- L = LENGTH
- P = GRADIENT
- K = R/100

- NOTES:**
- ALL DIMENSIONS ARE IN METRES UNLESS NOTED OTHERWISE.
  - DIGITAL TERRAIN MODEL DERIVED FROM TOPOGRAPHIC SURVEY AND LIDAR DATA PROVIDED BY THE NZ TRANSPORT AGENCY (REFER PR APPENDIX D).

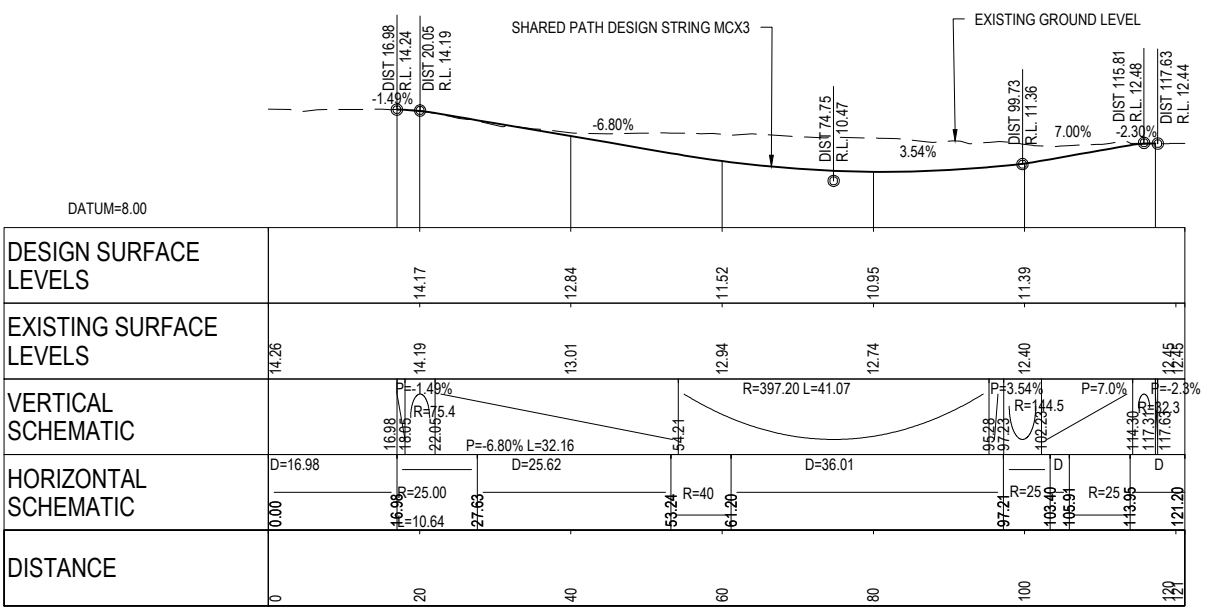

LONGITUDINAL SECTION ON CONTROL STRING MCX3  
SCALE HORIZ=1:500 VERT=1:200

■ ■ ■ ■ ■ ■ ■  
 ORIGINAL IN COLOUR

**PRELIMINARY**  
NOT FOR CONSTRUCTION

|                        |  |                             |                              |
|------------------------|--|-----------------------------|------------------------------|
| Scale (A1)<br>AS SHOWN | Design<br>P. Chowdhury<br>27.07.18         | Drawn<br>L.Wang<br>27.07.18 | Approved For<br>Construction |
| Scale (A3)             | Design Verifier                            | Drawn                       | Date                         |
|                        | Dwg Check                                  |                             |                              |
|                        | * Refer to Original Hardcopy for Signature |                             |                              |

|                 |              |          |                           |
|-----------------|--------------|----------|---------------------------|
| Design          | P. Chowdhury | 27.07.18 | Approved For Construction |
| Drawn           | L.Wang       | 27.07.18 |                           |
| Design Verifier |              |          | Date                      |
| Dwg Check       |              |          |                           |

|          |  |              |                 |
|----------|--|--------------|-----------------|
| Subject: | QUARRY ACCESS ROAD   | Discipline:  | CIVIL           |
| Title:   | SHARED PATH PLAN & LONGITUDINAL SECTION<br>ALIGNMENT STRING MCX3 | Drawing No.: | PP20-DR-CL-0412 |

|      |   |
|------|---|
| Rev. | B |
|------|---|

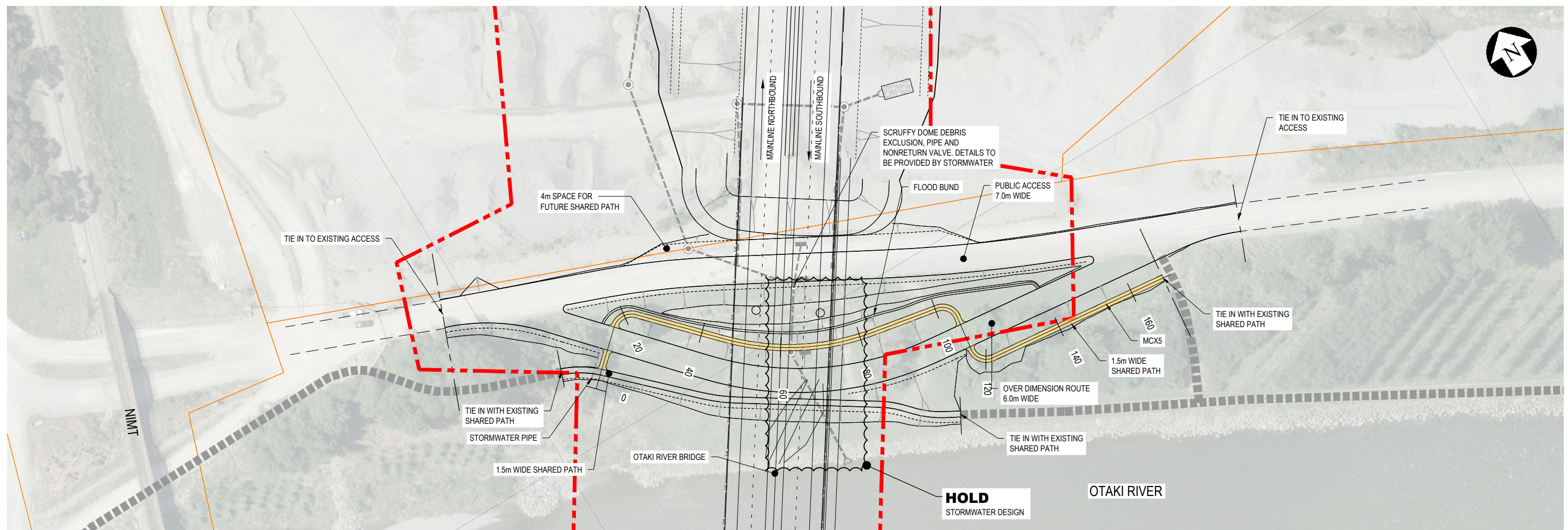

PLAN SHARED PATH - ALTERNATIVE ROUTE  
SCALE 1:500 (A1)

**LEGEND:**

- DESIGNATION BOUNDARY
- MSE WALL
- LOCAL ROAD
- PRIVATE/MAINTENANCE ACCESS
- STRUCTURE
- PATH
- EXISTING PATH
- EXISTING RAILWAY
- PROPOSED RAILWAY

**GEOMETRY LEGEND:**

- D = STRAIGHT LENGTH
- R = RADIUS
- CL = TRANSITION
- L = LENGTH
- P = GRADIENT
- K = R/100

**NOTES:**

1. ALL DIMENSIONS ARE IN METRES UNLESS NOTED OTHERWISE.
2. DIGITAL TERRAIN MODEL DERIVED FROM TOPOGRAPHIC SURVEY AND LIDAR DATA PROVIDED BY THE NZ TRANSPORT AGENCY (REFER PR APPENDIX D).

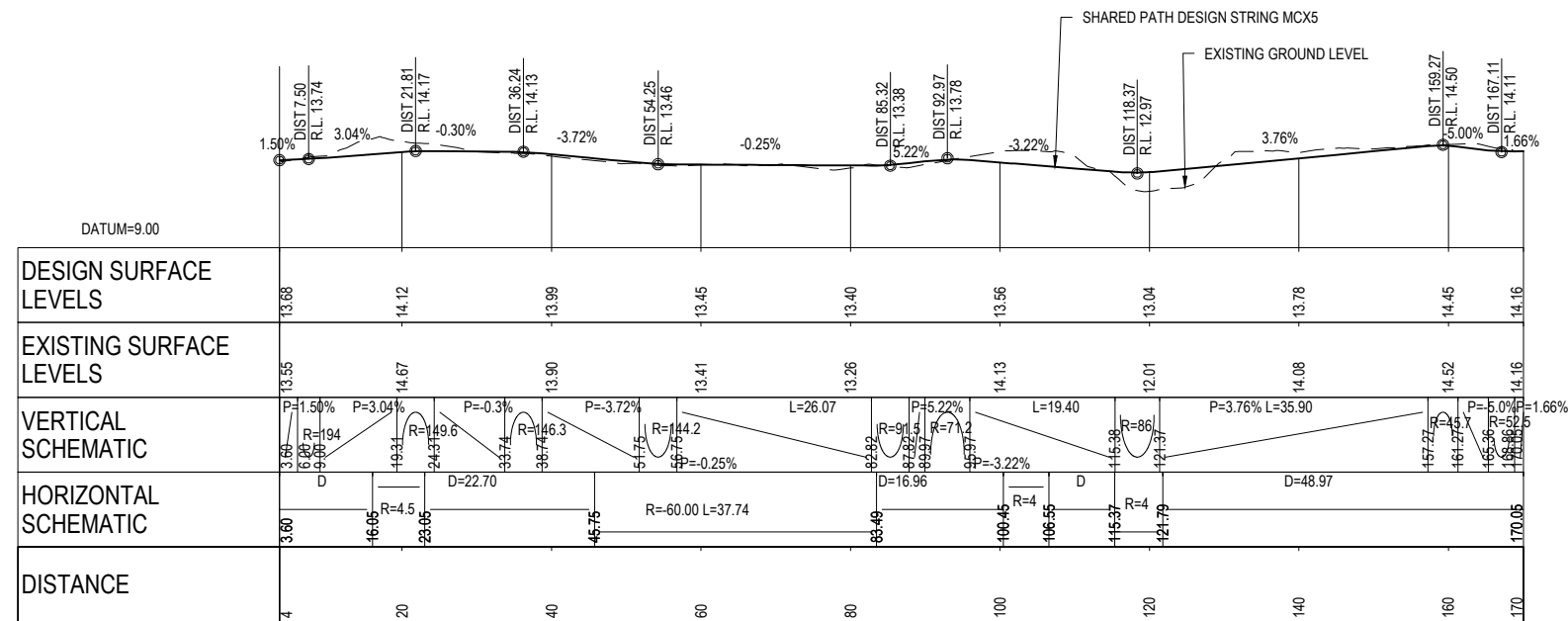

LONGITUDINAL SECTION ON CONTROL STRING MCX5  
SCALE HORIZ=1:500 VERT=1:200

ORIGINAL IN COLOUR

**PRELIMINARY**  
**NOT FOR CONSTRUCTION**

|                        |                                    |   |
|------------------------|------------------------------------|---|
| Scale (A1)<br>AS SHOWN | Design<br>P. Chowdhury<br>27.07.18 | Approved For<br>Construction<br>L. Wang<br>27.07.18 |
| Scale (A3)             | Drawn<br>L. Wang                   | Date  |
| No.                    | Revision                           | Date  |

|  |              |          |                           |
|--|--------------|----------|---------------------------|
| Design                                     | P. Chowdhury | 27.07.18 | Approved For Construction |
| Drawn                                      | L. Wang      | 27.07.18 | Date                      |
| Dwg Check                                  |              |          |                           |
| * Refer to Original Hardcopy for Signature |              |          |                           |

NZ TRANSPORT AGENCY  
Peka Peka to Otaki Expressway

Fletcher HIGGINS  
BECA  
Tonkin+Taylor

|          |  |
|----------|--|
| Subject: | QUARRY ACCESS ROAD   |
| Title:   | SHARED PATH PLAN & LONGITUDINAL SECTION<br>ALIGNMENT STRING MCX5 |

|              |                 |
|--------------|-----------------|
| Discipline:  | CIVIL           |
| Drawing No.: | PP20-DR-CL-0413 |
| Rev.:        | A               |

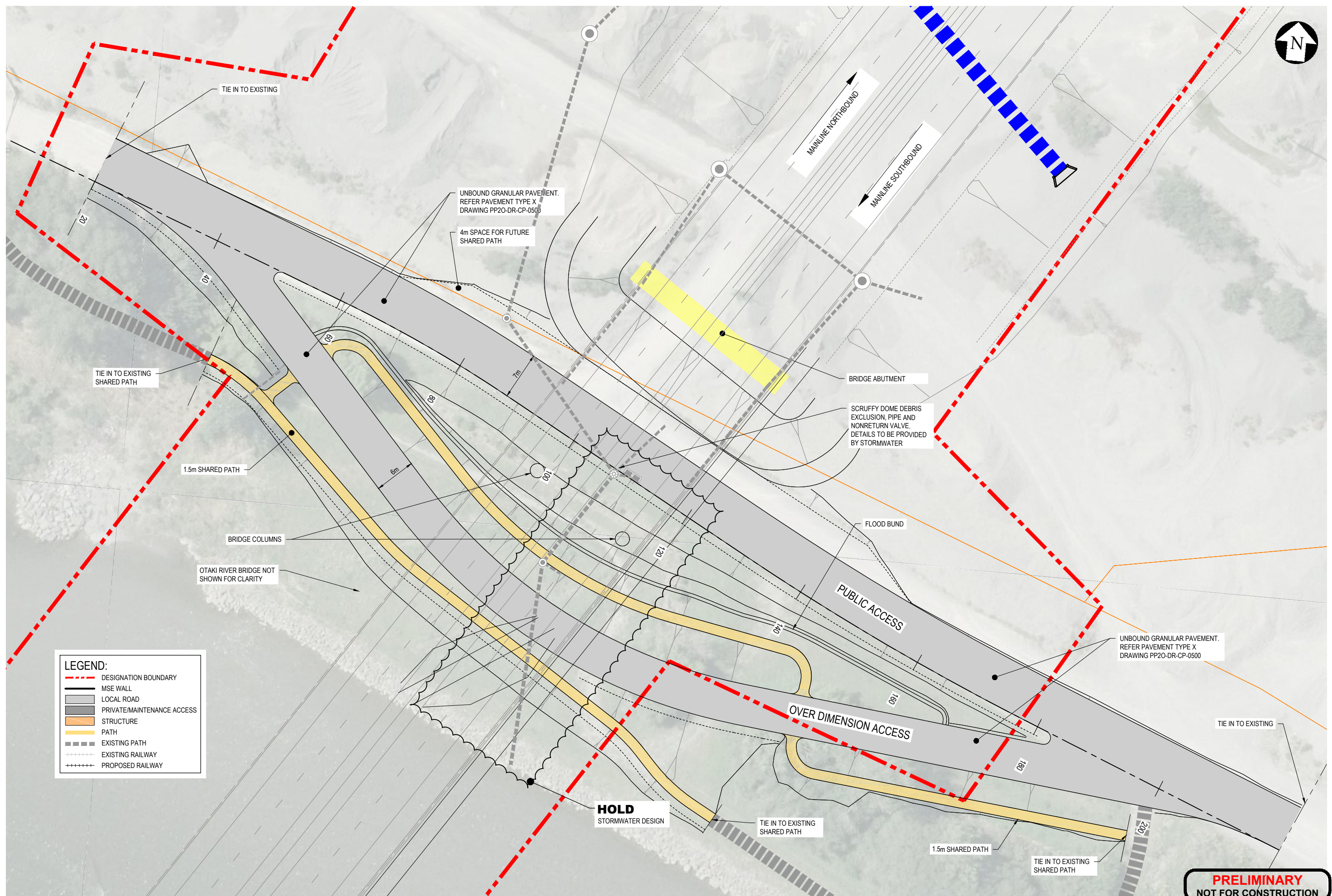

**LEGEND:**

- - - - - DESIGNATION BOUNDARY
- MSE WALL
- LOCAL ROAD
- PRIVATE/MAINTENANCE ACCESS
- STRUCTURE
- PATH
- EXISTING PATH
- EXISTING RAILWAY
- PROPOSED RAILWAY

**PRELIMINARY**  
NOT FOR CONSTRUCTION

|     |             |     |     |      |          |  |  |  |  |
|-----|-------------|-----|-----|------|----------|--|--|--|--|
| No. | Revision    |     |     |      |          |  |  |  |  |
| B   | 100% DESIGN |     |     |      |          |  |  |  |  |
| A   | 80% DESIGN  |     |     |      |          |  |  |  |  |
|     |             | PaC | DT  | SW   | 25.07.18 |  |  |  |  |
|     |             | GD  | PC  | BS   | 1.12.17  |  |  |  |  |
|     |             | By  | Chk | Appd | Date     |  |  |  |  |

|  |             |          |                           |
|--|-------------|----------|---------------------------|
| Design                                     | P.Chowdhury | 25.07.18 | Approved For Construction |
| Drawn                                      | L.Wang      | 25.07.18 | Date                      |
| Dwg Verifier                               |             |          |                           |
| Dwg Check                                  |             |          |                           |
| * Refer to Original Hardcopy for Signature |             |          |                           |

**Peka Peka to Ōtaki Expressway**

**BECA**

|                             |                             |
|-----------------------------|-----------------------------|
| Subject: QUARRY ACCESS ROAD | Discipline: CIVIL           |
| Title: DETAILED LAYOUT PLAN | Drawing No. PP20-DR-CL-0420 |
|                             | Rev. B                      |

Document No. R3000 - DESIGN DEVELOPMENT GENERAL/09 CAD/DRAWINGS/PP20-DR-CL-0420.DWG

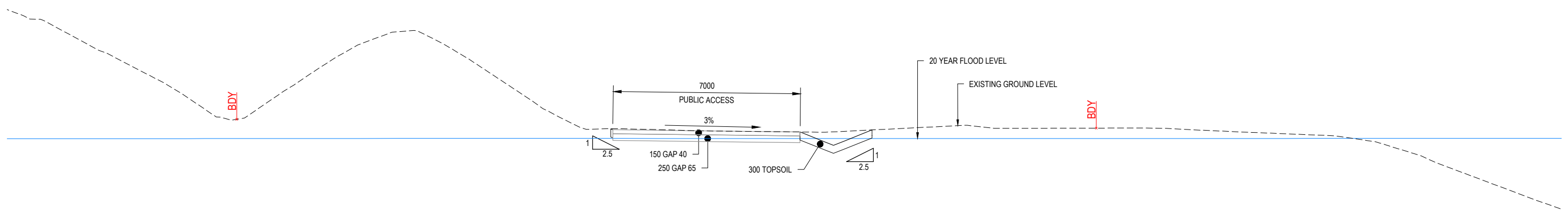

**A** QUARRY ACCESS ROAD  
CH 21  
1:75 AT A1

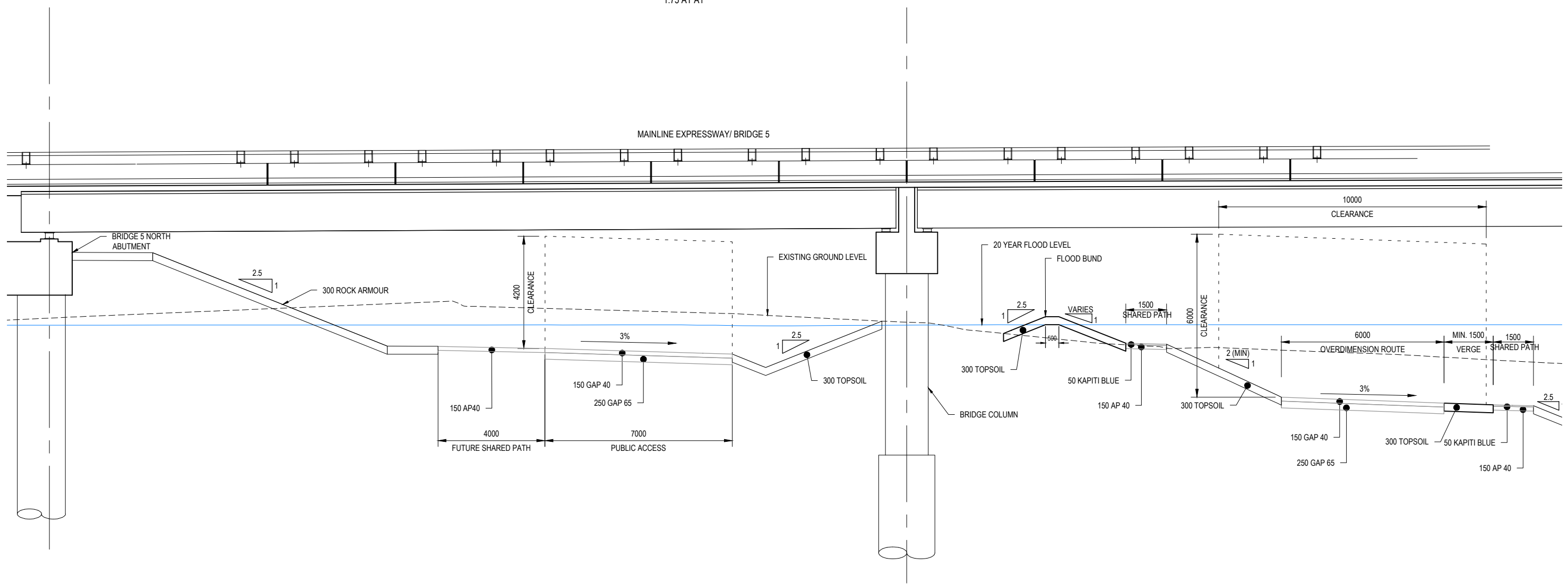

**B** QUARRY ACCESS ROAD  
CH 98  
1:75 AT A1

ORIGINAL IN COLOUR  
**PRELIMINARY**  
**NOT FOR CONSTRUCTION**

| No. | Revision    | By  | Chk | Appd | Date     |
|-----|-------------|-----|-----|------|----------|
| B   | 100% DESIGN | PaC | DT  | SW   | 27.07.18 |
| A   | 80% DESIGN  | RMT | PC  | BS   | 01.12.17 |

| Scale               | Design       | Drawn   | Date     | Approved For Construction |
|---------------------|--------------|---------|----------|---------------------------|
| Scale (A1)<br>1:75  | P. Chowdhury | L. Wang | 27.07.18 | 27.07.18                  |
| Scale (A3)<br>1:150 |              |         |          |                           |

\* Refer to Original Hardcopy for Signature

**NZ TRANSPORT AGENCY** WAIKATO REGION  
**Peka Peka to Ōtaki Expressway**  
**Fletcher HIGGINS**  
**BECA** **TFT** **Tonkin+Taylor**

|          |                        |              |                 |
|----------|------------------------|--------------|-----------------|
| Subject: | QUARRY ACCESS ROAD     | Discipline:  | CIVIL           |
| Title:   | TYPICAL CROSS SECTIONS | Drawing No.: | PP20-DR-CL-0450 |

|      |   |
|------|---|
| Rev. | B |
|------|---|



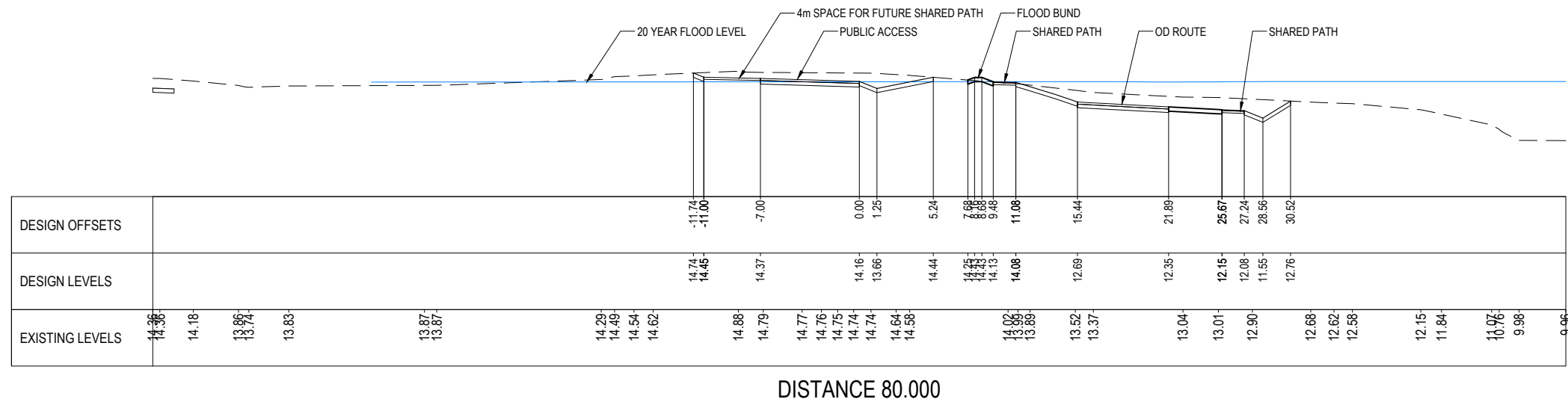

DISTANCE 80.000

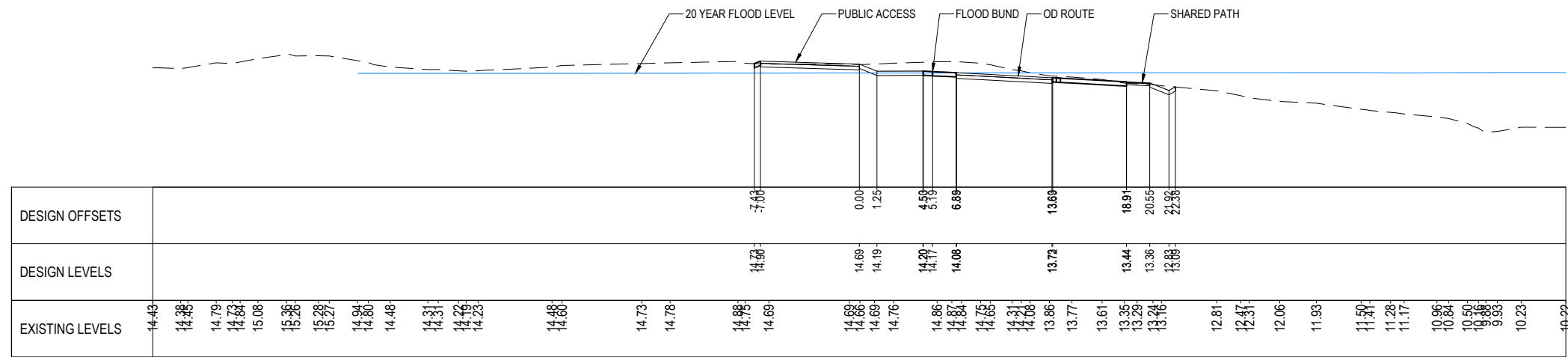

DISTANCE 60.000

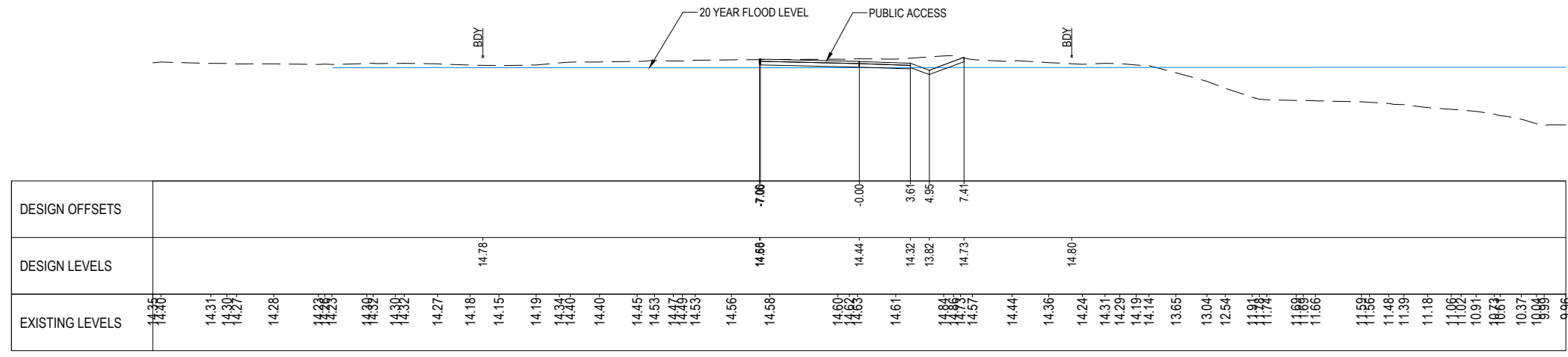

DISTANCE 40.000

ORIGINAL IN COLOUR

**PRELIMINARY  
NOT FOR CONSTRUCTION**

|     |             |    |     |      |      |
|-----|-------------|----|-----|------|------|
| No. | Revision    | By | Chk | Appd | Date |
| B   | 100% DESIGN |    |     |      |      |
| A   | 80% DESIGN  |    |     |      |      |

|            |       |        |              |          |                           |
|------------|-------|--------|--------------|----------|---------------------------|
| Scale (A1) | 1:200 | Design | P. Chowdhury | 27.07.18 | Approved For Construction |
| Scale (A3) | 1:400 | Drawn  | L. Wang      | 27.07.18 | Date                      |

|          |  |
|----------|--|
| Subject: | QUARRY ACCESS ROAD                         |
| Title:   | 20m INTERVAL CROSS SECTION<br>SHEET 1 OF 4 |

|              |                 |
|--------------|-----------------|
| Discipline:  | CIVIL           |
| Drawing No.: | PP20-SK-CL-0460 |
| Rev.:        | B               |

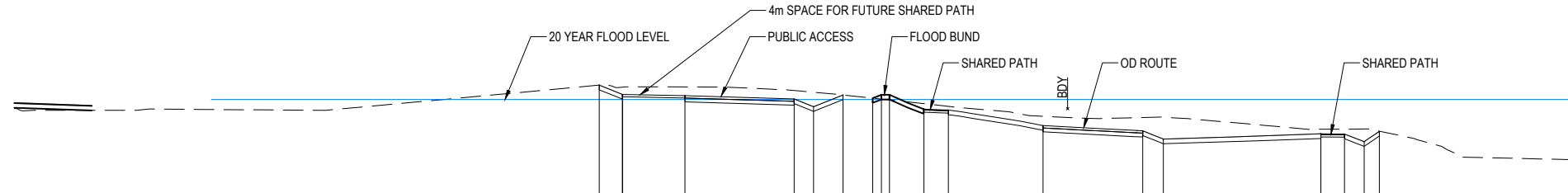

|                 |       |       |  |  |  |  |  |  |  |        |        |       |       |       |       |       |       |       |       |       |       |       |       |       |       |       |       |       |       |       |       |       |       |       |       |
|-----------------|-------|-------|--|--|--|--|--|--|--|--------|--------|-------|-------|-------|-------|-------|-------|-------|-------|-------|-------|-------|-------|-------|-------|-------|-------|-------|-------|-------|-------|-------|-------|-------|-------|
| DESIGN OFFSETS  |       |       |  |  |  |  |  |  |  | -12.50 | -11.00 | -7.00 | -0.00 | 1.25  | 3.13  | 5.00  | 6.12  | 8.32  | 9.89  | 15.96 | 22.35 | 23.68 | 33.78 | 35.29 | 36.55 | 37.53 |       |       |       |       |       |       |       |       |       |
| DESIGN LEVELS   |       |       |  |  |  |  |  |  |  | 15.24  | 14.65  | 14.57 | 14.36 | 13.86 | 14.61 | 14.41 | 14.62 | 13.71 | 13.65 | 12.65 | 13.73 | 12.31 | 11.78 | 12.12 | 12.11 | 11.62 | 12.27 |       |       |       |       |       |       |       |       |
| EXISTING LEVELS | 13.56 | 13.62 |  |  |  |  |  |  |  | 14.87  | 15.28  | 15.14 | 15.12 | 15.03 | 14.93 | 14.58 | 14.62 | 14.06 | 13.81 | 13.53 | 13.29 | 13.14 | 13.10 | 13.20 | 13.14 | 13.09 | 12.67 | 12.40 | 12.41 | 12.43 | 11.99 | 11.82 | 11.32 | 10.85 | 10.46 |

DISTANCE 140.000

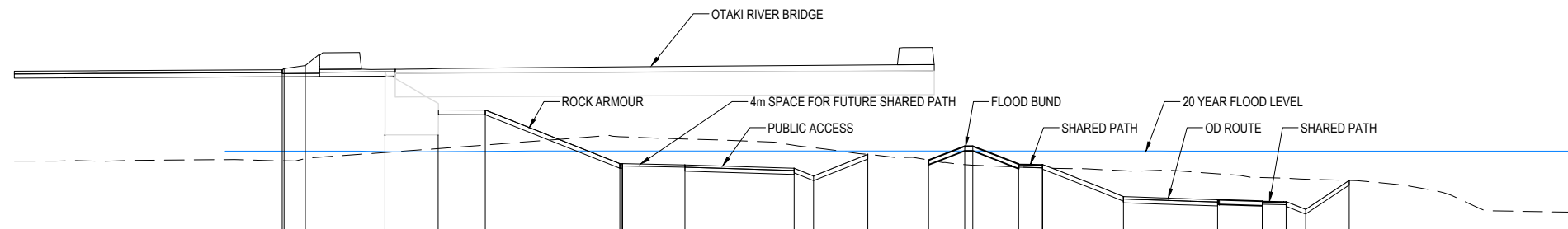

|                 |       |       |       |       |       |  |  |  |  |  |  |  |  |  |  |  |  |  |  |  |  |  |  |  |  |  |  |  |  |  |  |  |  |  |  |  |
|-----------------|-------|-------|-------|-------|-------|--|--|--|--|--|--|--|--|--|--|--|--|--|--|--|--|--|--|--|--|--|--|--|--|--|--|--|--|--|--|--|
| DESIGN OFFSETS  |       |       |       |       |       |  |  |  |  |  |  |  |  |  |  |  |  |  |  |  |  |  |  |  |  |  |  |  |  |  |  |  |  |  |  |  |
| DESIGN LEVELS   |       |       |       |       |       |  |  |  |  |  |  |  |  |  |  |  |  |  |  |  |  |  |  |  |  |  |  |  |  |  |  |  |  |  |  |  |
| EXISTING LEVELS | 13.64 | 13.61 | 13.64 | 13.60 | 13.66 |  |  |  |  |  |  |  |  |  |  |  |  |  |  |  |  |  |  |  |  |  |  |  |  |  |  |  |  |  |  |  |

DISTANCE 120.000

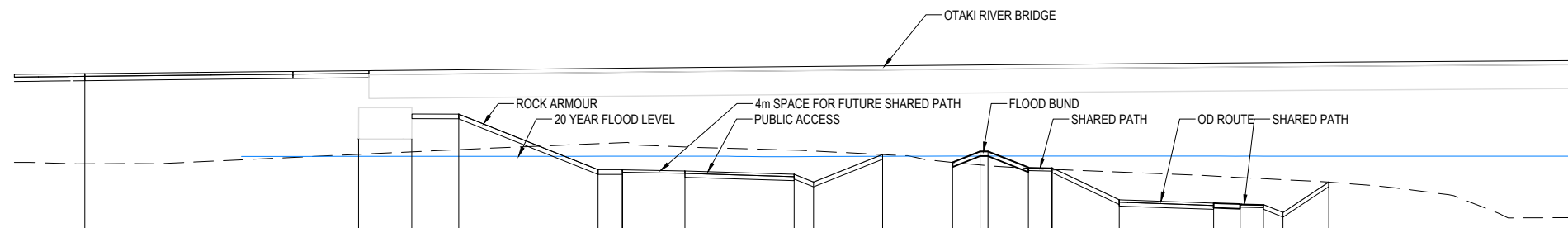

|                 |       |       |       |       |       |  |  |  |  |  |  |  |  |  |  |  |  |  |  |  |  |  |  |  |  |  |  |  |  |  |  |  |  |  |  |  |
|-----------------|-------|-------|-------|-------|-------|--|--|--|--|--|--|--|--|--|--|--|--|--|--|--|--|--|--|--|--|--|--|--|--|--|--|--|--|--|--|--|
| DESIGN OFFSETS  |       |       |       |       |       |  |  |  |  |  |  |  |  |  |  |  |  |  |  |  |  |  |  |  |  |  |  |  |  |  |  |  |  |  |  |  |
| DESIGN LEVELS   |       |       |       |       |       |  |  |  |  |  |  |  |  |  |  |  |  |  |  |  |  |  |  |  |  |  |  |  |  |  |  |  |  |  |  |  |
| EXISTING LEVELS | 13.80 | 13.71 | 13.73 | 13.71 | 13.75 |  |  |  |  |  |  |  |  |  |  |  |  |  |  |  |  |  |  |  |  |  |  |  |  |  |  |  |  |  |  |  |

DISTANCE 100.000

ORIGINAL IN COLOUR

**PRELIMINARY**  
**NOT FOR CONSTRUCTION**

|     |             |     |     |      |          |
|-----|-------------|-----|-----|------|----------|
| No. | Revision    | By  | Chk | Appd | Date     |
| B   | 100% DESIGN | PAC | DT  | SW   | 27.07.18 |
| A   | 80% DESIGN  | RMT | PC  | BS   | 01.12.17 |

|  |       |              |              |          |                           |
|--|-------|--------------|--------------|----------|---------------------------|
| Scale (A1)                                 | 1:200 | Design       | P. Chowdhury | 27.07.18 | Approved For Construction |
| Scale (A3)                                 |       | Drawn        | L. Wang      | 27.07.18 | Date                      |
|  |       | Dwg Verifier |              |          |                           |
|  |       | Dwg Check    |              |          |                           |
| * Refer to Original Hardcopy for Signature |       |              |              |          |                           |

**NZ TRANSPORT AGENCY** **Waka Kotahi** **Peka Peka to Otaki Expressway** **Fletcher HIGGINS** **BECA** **Tonkin+Taylor**

|          |   |
|----------|---|
| Subject: | QUARRY ACCESS ROAD                          |
| Title:   | 20m INTERVAL CROSS SECTIONS<br>SHEET 2 OF 4 |

|             |                 |
|-------------|-----------------|
| Discipline  | CIVIL           |
| Drawing No. | PP20-SK-CL-0461 |
| Rev.        | B               |

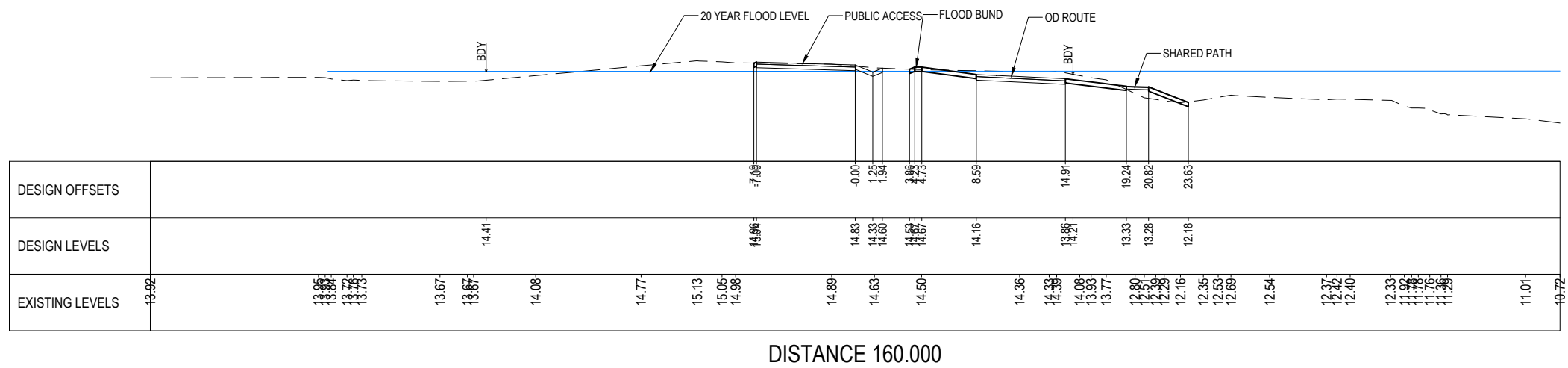
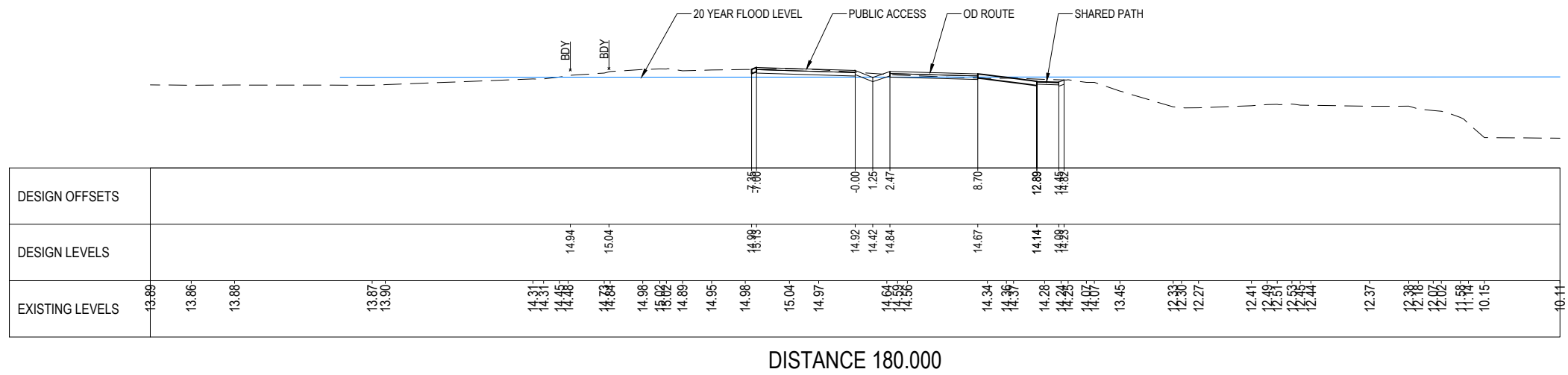

ORIGINAL IN COLOUR

**PRELIMINARY**  
**NOT FOR CONSTRUCTION**

|     |             |     |     |      |          |
|-----|-------------|-----|-----|------|----------|
| No. | Revision    | By  | Chk | Appd | Date     |
| B   | 100% DESIGN | PAC | DT  | SW   | 27.07.18 |
| A   | 80% DESIGN  | RMT | PC  | BS   | 01.12.17 |

|            |       |              |              |          |                           |
|------------|-------|--------------|--------------|----------|---------------------------|
| Scale (A1) | 1:200 | Design       | P. Chowdhury | 27.07.18 | Approved For Construction |
| Scale (A3) |       | Drawn        | L. Wang      | 27.07.18 | Date                      |
|            |       | Dwg Verifier |              |          |                           |
|            |       | Dwg Check    |              |          |                           |

\* Refer to Original Hardcopy for Signature

**NZ TRANSPORT AGENCY** WAIKAŪTĀKI

**Peka Peka to Ōtaki Expressway**

**Fletcher HIGGINS**

**BECA** **TFT** **Tonkin+Taylor**

|          |   |
|----------|---|
| Subject: | QUARRY ACCESS ROAD                          |
| Title:   | 20m INTERVAL CROSS SECTIONS<br>SHEET 3 OF 4 |

|              |                 |
|--------------|-----------------|
| Discipline:  | CIVIL           |
| Drawing No.: | PP20-SK-CL-0462 |
| Rev.:        | B               |

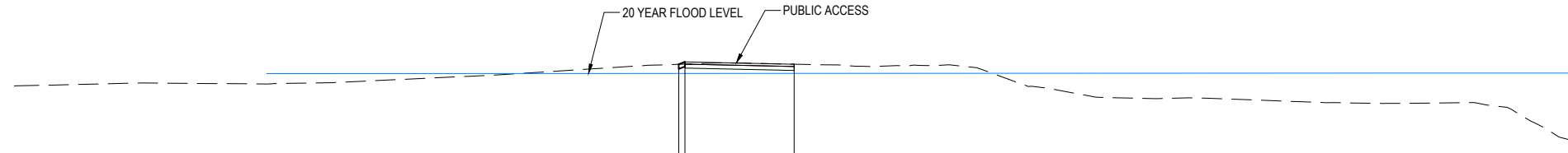

| DESIGN OFFSETS  |       |       |       |       |  |       |       | -7.00 | 0.00  |  |       |       |       |       |       |       |       |       |       |       |       |       |       |       |       |       |       |       |       |       |       |       |       |       |       |       |       |
|-----------------|-------|-------|-------|-------|--|-------|-------|-------|-------|--|-------|-------|-------|-------|-------|-------|-------|-------|-------|-------|-------|-------|-------|-------|-------|-------|-------|-------|-------|-------|-------|-------|-------|-------|-------|-------|-------|
| DESIGN LEVELS   |       |       |       |       |  |       |       | 15.08 | 15.10 |  |       |       |       |       |       |       |       |       |       |       |       |       |       |       |       |       |       |       |       |       |       |       |       |       |       |       |       |
| EXISTING LEVELS | 13.71 | 13.75 | 13.89 | 13.88 |  | 13.83 | 13.91 |       | 14.41 |  | 15.03 | 15.06 | 15.18 | 15.17 | 15.06 | 15.05 | 14.96 | 14.95 | 15.01 | 15.00 | 15.06 | 14.87 | 13.98 | 13.66 | 13.56 | 12.97 | 12.88 | 12.94 | 12.92 | 12.70 | 12.63 | 12.48 | 12.32 | 11.99 | 10.96 | 10.41 | 10.25 |

DISTANCE 220

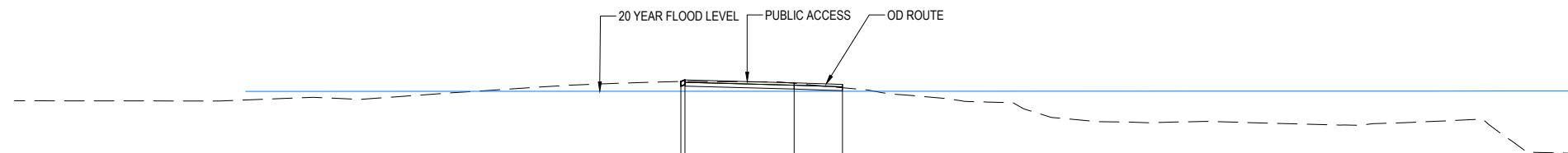

| DESIGN OFFSETS  |       |  |  |  |  |       |       | -7.00 | -0.00 | 3.10  |       |       |       |       |       |       |       |       |       |       |       |       |       |       |       |       |       |       |       |       |  |       |       |       |       |       |       |       |       |       |       |
|-----------------|-------|--|--|--|--|-------|-------|-------|-------|-------|-------|-------|-------|-------|-------|-------|-------|-------|-------|-------|-------|-------|-------|-------|-------|-------|-------|-------|-------|-------|--|-------|-------|-------|-------|-------|-------|-------|-------|-------|-------|
| DESIGN LEVELS   |       |  |  |  |  |       |       | 15.08 | 15.01 | 14.91 |       |       |       |       |       |       |       |       |       |       |       |       |       |       |       |       |       |       |       |       |  |       |       |       |       |       |       |       |       |       |       |
| EXISTING LEVELS | 13.85 |  |  |  |  | 13.84 | 13.96 | 14.08 | 13.94 | 14.34 | 14.86 | 15.03 | 15.09 | 15.09 | 15.08 | 15.07 | 14.94 | 14.55 | 14.37 | 14.23 | 14.00 | 13.81 | 13.78 | 13.73 | 13.33 | 12.78 | 12.52 | 12.48 | 12.44 | 12.53 |  | 12.31 | 12.28 | 12.28 | 12.38 | 12.42 | 12.57 | 12.88 | 11.57 | 10.76 | 10.48 |

DISTANCE 200.000



**PRELIMINARY**  
**NOT FOR CONSTRUCTION**

|     |             |    |     |      |      |          |  |  |  |
|-----|-------------|----|-----|------|------|----------|--|--|--|
|     |             |    |     |      |      |          |  |  |  |
| B   | 100% DESIGN |    | PaC | DT   | SW   | 27.07.18 |  |  |  |
| A   | 80% DESIGN  |    | RMT | PC   | BS   | 01.12.17 |  |  |  |
| No. | Revision    | By | Chk | Appd | Date |          |  |  |  |

|  |              |          |                           |
|--|--------------|----------|---------------------------|
| Design                                     | P. Chowdhury | 27.07.18 | Approved For Construction |
| Drawn                                      | L. Wang      | 27.07.18 |                           |
| Dwg Verifier                               |              |          |                           |
| Dwg Check                                  |              |          |                           |
| * Refer to Original Hardcopy for Signature |              |          |                           |



**Peka Peka to Otaki Expressway**



|          |   |
|----------|---|
| Subject: | QUARRY ACCESS ROAD                          |
| Title:   | 20m INTERVAL CROSS SECTIONS<br>SHEET 4 OF 4 |

|              |                 |
|--------------|-----------------|
| Discipline:  | CIVIL           |
| Drawing No.: | PP20-SK-CL-0463 |
| Rev.:        | B               |

# APPENDIX D – PROGRAMME

| Activity Name                                       | Orig Dur | Rem Dur | Start       | Finish      | 2018 |     |     |     |     |     |     |     |     |     |     |     | 2019 |     |     |     |     |     |     |     |  |  |  |  | 2020 |
|---|----------|---------|-------------|-------------|------|-----|-----|-----|-----|-----|-----|-----|-----|-----|-----|-----|------|-----|-----|-----|-----|-----|-----|-----|--|--|--|--|------|
|   |          |         |             |             | Jun  | Jul | Aug | Sep | Oct | Nov | Dec | Jan | Feb | Mar | Apr | May | Jun  | Jul | Aug | Sep | Oct | Nov | Dec | Jan |  |  |  |  |      |
|   |          |         |             |             |      |     |     |     |     |     |     |     |     |     |     |     |      |     |     |     |     |     |     |     |  |  |  |  |      |
| <b>Peka Peka to Otaki Expressway - Master</b>       | 568d     | 390d    | 20-Sep-17 A | 24-Jan-20   |      |     |     |     |     |     |     |     |     |     |     |     |      |     |     |     |     |     |     |     |  |  |  |  |      |
| <b>Construction</b>                                 | 568d     | 390d    | 20-Sep-17 A | 24-Jan-20   |      |     |     |     |     |     |     |     |     |     |     |     |      |     |     |     |     |     |     |     |  |  |  |  |      |
| <b>Zone 1 (North): Ch 0 - 3800</b>                  | 568d     | 390d    | 20-Sep-17 A | 24-Jan-20   |      |     |     |     |     |     |     |     |     |     |     |     |      |     |     |     |     |     |     |     |  |  |  |  |      |
| <b>Structures</b>                                   | 568d     | 390d    | 20-Sep-17 A | 24-Jan-20   |      |     |     |     |     |     |     |     |     |     |     |     |      |     |     |     |     |     |     |     |  |  |  |  |      |
| <b>Bridge 5 - Otaki River Bridge (Ch 3450-3800)</b> | 568d     | 390d    | 20-Sep-17 A | 24-Jan-20   |      |     |     |     |     |     |     |     |     |     |     |     |      |     |     |     |     |     |     |     |  |  |  |  |      |
| <b>Enabling Works</b>                               | 10d      | 0d      | 08-Jan-18 A | 19-Jan-18 A |      |     |     |     |     |     |     |     |     |     |     |     |      |     |     |     |     |     |     |     |  |  |  |  |      |
| <b>Piling</b>                                       | 286d     | 65d     | 20-Sep-17 A | 19-Nov-18   |      |     |     |     |     |     |     |     |     |     |     |     |      |     |     |     |     |     |     |     |  |  |  |  |      |
| <b>Ground Works</b>                                 | 116d     | 116d    | 13-Aug-18   | 07-Feb-19   |      |     |     |     |     |     |     |     |     |     |     |     |      |     |     |     |     |     |     |     |  |  |  |  |      |
| <b>Stream Diversion</b>                             | 12d      | 12d     | 13-Aug-18   | 31-Aug-18   |      |     |     |     |     |     |     |     |     |     |     |     |      |     |     |     |     |     |     |     |  |  |  |  |      |
| <b>Abutments</b>                                    | 62d      | 62d     | 18-Oct-18   | 29-Jan-19   |      |     |     |     |     |     |     |     |     |     |     |     |      |     |     |     |     |     |     |     |  |  |  |  |      |
| <b>Rip Rap</b>                                      | 57d      | 57d     | 05-Nov-18   | 07-Feb-19   |      |     |     |     |     |     |     |     |     |     |     |     |      |     |     |     |     |     |     |     |  |  |  |  |      |
| <b>Substructure</b>                                 | 196d     | 166d    | 08-May-18 A | 25-Feb-19   |      |     |     |     |     |     |     |     |     |     |     |     |      |     |     |     |     |     |     |     |  |  |  |  |      |
| <b>51 Abutments</b>                                 | 79d      | 79d     | 10-Sep-18   | 11-Jan-19   |      |     |     |     |     |     |     |     |     |     |     |     |      |     |     |     |     |     |     |     |  |  |  |  |      |
| <b>North Abutment</b>                               | 24d      | 24d     | 27-Nov-18   | 11-Jan-19   |      |     |     |     |     |     |     |     |     |     |     |     |      |     |     |     |     |     |     |     |  |  |  |  |      |
| <b>South Abutment</b>                               | 28d      | 28d     | 10-Sep-18   | 17-Oct-18   |      |     |     |     |     |     |     |     |     |     |     |     |      |     |     |     |     |     |     |     |  |  |  |  |      |
| <b>53 Columns</b>                                   | 143d     | 112d    | 08-May-18 A | 26-Nov-18   |      |     |     |     |     |     |     |     |     |     |     |     |      |     |     |     |     |     |     |     |  |  |  |  |      |
| <b>Stage 1 Columns (5 Piers)</b>                    | 46d      | 15d     | 08-May-18 A | 11-Jul-18   |      |     |     |     |     |     |     |     |     |     |     |     |      |     |     |     |     |     |     |     |  |  |  |  |      |
| <b>Stage 2 Columns (4 Piers)</b>                    | 37d      | 37d     | 04-Oct-18   | 26-Nov-18   |      |     |     |     |     |     |     |     |     |     |     |     |      |     |     |     |     |     |     |     |  |  |  |  |      |
| <b>54 Crosshead</b>                                 | 166d     | 166d    | 20-Jun-18   | 25-Feb-19   |      |     |     |     |     |     |     |     |     |     |     |     |      |     |     |     |     |     |     |     |  |  |  |  |      |
| <b>Stage 1 Crossheads (5 Piers)</b>                 | 73d      | 73d     | 20-Jun-18   | 28-Sep-18   |      |     |     |     |     |     |     |     |     |     |     |     |      |     |     |     |     |     |     |     |  |  |  |  |      |
| <b>Stage 2 Crossheads (4 Piers)</b>                 | 82d      | 82d     | 16-Oct-18   | 25-Feb-19   |      |     |     |     |     |     |     |     |     |     |     |     |      |     |     |     |     |     |     |     |  |  |  |  |      |
| <b>Superstructure</b>                               | 468d     | 347d    | 11-Dec-17 A | 12-Nov-19   |      |     |     |     |     |     |     |     |     |     |     |     |      |     |     |     |     |     |     |     |  |  |  |  |      |
| <b>61 Bearings</b>                                  | 120d     | 62d     | 11-Dec-17 A | 13-Sep-18   |      |     |     |     |     |     |     |     |     |     |     |     |      |     |     |     |     |     |     |     |  |  |  |  |      |
| <b>Beams</b>  | 202d     | 202d    | 27-Aug-18   | 27-Jun-19   |      |     |     |     |     |     |     |     |     |     |     |     |      |     |     |     |     |     |     |     |  |  |  |  |      |
| <b>Span 1</b>                                       | 84d      | 84d     | 08-Feb-19   | 11-Jun-19   |      |     |     |     |     |     |     |     |     |     |     |     |      |     |     |     |     |     |     |     |  |  |  |  |      |
| <b>Span 2</b>                                       | 27d      | 27d     | 21-May-19   | 27-Jun-19   |      |     |     |     |     |     |     |     |     |     |     |     |      |     |     |     |     |     |     |     |  |  |  |  |      |
| <b>Span 3</b>                                       | 29d      | 29d     | 29-Mar-19   | 13-May-19   |      |     |     |     |     |     |     |     |     |     |     |     |      |     |     |     |     |     |     |     |  |  |  |  |      |
| <b>Span 4</b>                                       | 57d      | 57d     | 17-Dec-18   | 21-Mar-19   |      |     |     |     |     |     |     |     |     |     |     |     |      |     |     |     |     |     |     |     |  |  |  |  |      |
| <b>Span 5</b>                                       | 62d      | 62d     | 14-Jan-19   | 11-Apr-19   |      |     |     |     |     |     |     |     |     |     |     |     |      |     |     |     |     |     |     |     |  |  |  |  |      |
| <b>Span 6</b>                                       | 9d       | 9d      | 27-Aug-18   | 06-Sep-18   |      |     |     |     |     |     |     |     |     |     |     |     |      |     |     |     |     |     |     |     |  |  |  |  |      |
| <b>Span 7</b>                                       | 9d       | 9d      | 24-Sep-18   | 04-Oct-18   |      |     |     |     |     |     |     |     |     |     |     |     |      |     |     |     |     |     |     |     |  |  |  |  |      |
| <b>Span 8</b>                                       | 9d       | 9d      | 26-Sep-18   | 08-Oct-18   |      |     |     |     |     |     |     |     |     |     |     |     |      |     |     |     |     |     |     |     |  |  |  |  |      |
| <b>Span 9</b>                                       | 15d      | 15d     | 09-Oct-18   | 30-Oct-18   |      |     |     |     |     |     |     |     |     |     |     |     |      |     |     |     |     |     |     |     |  |  |  |  |      |
| <b>Span 10</b>                                      | 27d      | 27d     | 18-Oct-18   | 26-Nov-18   |      |     |     |     |     |     |     |     |     |     |     |     |      |     |     |     |     |     |     |     |  |  |  |  |      |
| <b>63 Diaphragms</b>                                | 223d     | 223d    | 07-Sep-18   | 08-Aug-19   |      |     |     |     |     |     |     |     |     |     |     |     |      |     |     |     |     |     |     |     |  |  |  |  |      |
| <b>Span 1</b>                                       | 15d      | 15d     | 19-Jul-19   | 08-Aug-19   |      |     |     |     |     |     |     |     |     |     |     |     |      |     |     |     |     |     |     |     |  |  |  |  |      |
| <b>Span 2</b>                                       | 15d      | 15d     | 28-Jun-19   | 18-Jul-19   |      |     |     |     |     |     |     |     |     |     |     |     |      |     |     |     |     |     |     |     |  |  |  |  |      |
| <b>Span 3</b>                                       | 14d      | 14d     | 31-May-19   | 20-Jun-19   |      |     |     |     |     |     |     |     |     |     |     |     |      |     |     |     |     |     |     |     |  |  |  |  |      |
| <b>Span 4</b>                                       | 16d      | 16d     | 09-May-19   | 30-May-19   |      |     |     |     |     |     |     |     |     |     |     |     |      |     |     |     |     |     |     |     |  |  |  |  |      |
| <b>Span 5</b>                                       | 16d      | 16d     | 12-Apr-19   | 08-May-19   |      |     |     |     |     |     |     |     |     |     |     |     |      |     |     |     |     |     |     |     |  |  |  |  |      |
| <b>Span 6</b>                                       | 15d      | 15d     | 07-Sep-18   | 27-Sep-18   |      |     |     |     |     |     |     |     |     |     |     |     |      |     |     |     |     |     |     |     |  |  |  |  |      |
| <b>Span 7</b>                                       | 15d      | 15d     | 05-Oct-18   | 26-Oct-18   |      |     |     |     |     |     |     |     |     |     |     |     |      |     |     |     |     |     |     |     |  |  |  |  |      |
| <b>Span 8</b>                                       | 16d      | 16d     | 25-Oct-18   | 15-Nov-18   |      |     |     |     |     |     |     |     |     |     |     |     |      |     |     |     |     |     |     |     |  |  |  |  |      |
| <b>Span 9</b>                                       | 15d      | 15d     | 16-Nov-18   | 06-Dec-18   |      |     |     |     |     |     |     |     |     |     |     |     |      |     |     |     |     |     |     |     |  |  |  |  |      |
| <b>Span 10</b>                                      | 15d      | 15d     | 07-Dec-18   | 10-Jan-19   |      |     |     |     |     |     |     |     |     |     |     |     |      |     |     |     |     |     |     |     |  |  |  |  |      |
| <b>64 Deck</b>                                      | 226d     | 226d    | 28-Sep-18   | 03-Sep-19   |      |     |     |     |     |     |     |     |     |     |     |     |      |     |     |     |     |     |     |     |  |  |  |  |      |
| <b>Span 1</b>                                       | 18d      | 18d     | 09-Aug-19   | 03-Sep-19   |      |     |     |     |     |     |     |     |     |     |     |     |      |     |     |     |     |     |     |     |  |  |  |  |      |
| <b>Span 2</b>                                       | 18d      | 18d     | 19-Jul-19   | 13-Aug-19   |      |     |     |     |     |     |     |     |     |     |     |     |      |     |     |     |     |     |     |     |  |  |  |  |      |
| <b>Span 3</b>                                       | 18d      | 18d     | 21-Jun-19   | 16-Jul-19   |      |     |     |     |     |     |     |     |     |     |     |     |      |     |     |     |     |     |     |     |  |  |  |  |      |
| <b>Span 4</b>                                       | 18d      | 18d     | 31-May-19   | 26-Jun-19   |      |     |     |     |     |     |     |     |     |     |     |     |      |     |     |     |     |     |     |     |  |  |  |  |      |
| <b>Span 5</b>                                       | 18d      | 18d     | 09-May-19   | 04-Jun-19   |      |     |     |     |     |     |     |     |     |     |     |     |      |     |     |     |     |     |     |     |  |  |  |  |      |
| <b>Span 6</b>                                       | 17d      | 17d     | 28-Sep-18   | 23-Oct-18   |      |     |     |     |     |     |     |     |     |     |     |     |      |     |     |     |     |     |     |     |  |  |  |  |      |
| <b>Span 7</b>                                       | 18d      | 18d     | 29-Oct-18   | 21-Nov-18   |      |     |     |     |     |     |     |     |     |     |     |     |      |     |     |     |     |     |     |     |  |  |  |  |      |
| <b>Span 8</b>                                       | 18d      | 18d     | 22-Nov-18   | 17-Dec-18   |      |     |     |     |     |     |     |     |     |     |     |     |      |     |     |     |     |     |     |     |  |  |  |  |      |
| <b>Span 9</b>                                       | 18d      | 18d     | 18-Dec-18   | 24-Jan-19   |      |     |     |     |     |     |     |     |     |     |     |     |      |     |     |     |     |     |     |     |  |  |  |  |      |
| <b>Span 10</b>                                      | 18d      | 18d     | 11-Jan-19   | 07-Feb-19   |      |     |     |     |     |     |     |     |     |     |     |     |      |     |     |     |     |     |     |     |  |  |  |  |      |
| <b>65 Expansion Joints</b>                          | 159d     | 159d    | 08-Feb-19   | 24-Sep-19   |      |     |     |     |     |     |     |     |     |     |     |     |      |     |     |     |     |     |     |     |  |  |  |  |      |
| <b>North Expansion Joints</b>                       | 15d      | 15d     | 04-Sep-19   | 24-Sep-19   |      |     |     |     |     |     |     |     |     |     |     |     |      |     |     |     |     |     |     |     |  |  |  |  |      |
| <b>South Expansion Joints</b>                       | 17d      | 17d     | 08-Feb-19   | 04-Mar-19   |      |     |     |     |     |     |     |     |     |     |     |     |      |     |     |     |     |     |     |     |  |  |  |  |      |
| <b>66 Barriers</b>                                  | 258d     | 258d    | 24-Oct-18   | 12-Nov-19   |      |     |     |     |     |     |     |     |     |     |     |     |      |     |     |     |     |     |     |     |  |  |  |  |      |
| <b>Ancillary</b>                                    | 77d      | 77d     | 25-Sep-19   | 24-Jan-20   |      |     |     |     |     |     |     |     |     |     |     |     |      |     |     |     |     |     |     |     |  |  |  |  |      |
| <b>Approach slabs</b>                               | 9d       | 9d      | 25-Sep-19   | 07-Oct-19   |      |     |     |     |     |     |     |     |     |     |     |     |      |     |     |     |     |     |     |     |  |  |  |  |      |
| <b>North Abutment</b>                               | 9d       | 9d      | 25-Sep-19   | 07-Oct-19   |      |     |     |     |     |     |     |     |     |     |     |     |      |     |     |     |     |     |     |     |  |  |  |  |      |
| <b>South Abutment</b>                               | 9d       | 9d      | 25-Sep-19   | 07-Oct-19   |      |     |     |     |     |     |     |     |     |     |     |     |      |     |     |     |     |     |     |     |  |  |  |  |      |
| <b>Metalwork</b>                                    | 19d      | 19d     | 13-Nov-19   | 09-Dec-19   |      |     |     |     |     |     |     |     |     |     |     |     |      |     |     |     |     |     |     |     |  |  |  |  |      |
| <b>Miscellaneous</b>                                | 24d      | 24d     | 10-Dec-19   | 24-Jan-20   |      |     |     |     |     |     |     |     |     |     |     |     |      |     |     |     |     |     |     |     |  |  |  |  |      |
| <b>Surfacing</b>                                    | 9d       | 9d      | 14-Jan-20   | 24-Jan-20   |      |     |     |     |     |     |     |     |     |     |     |     |      |     |     |     |     |     |     |     |  |  |  |  |      |



Peka Peka to Otaki Bridge 5 Programme

- Remaining Level of Effort
- Actual Level of Effort
- Actual Work
- Remaining...
- ▼ Milestones
- Critical Re...



# APPENDIX E – SITE SPECIFIC TRAFFIC MANAGEMENT PLAN

---

# Site Specific Traffic Management Plan

## – Peka Peka to Ōtaki Project

FCCL-TM-MPN-0005

---

Revision A – August 2018



| <b>Contents</b> |   |
|-----------------|---|
| <b>1</b>        | <b>Introduction..... 1</b>  |
| 1.1             | The SSTMP and TMP Process..... 1  |
| <b>2</b>        | <b>SSTMP CONSENT CONSIDERATIONS..... 2</b>  |
| 2.1             | Proposed Temporary Traffic Management Measures - BOI condition 34 b (i)..... 2                  |
| 2.2             | Assessment of delays - BOI condition 34 b (ii)..... 2   |
| 2.3             | Detour Routes - BOI condition 34 b (iii)..... 2   |
| 2.4             | Existing Accesses - BOI condition 34 b (iv)..... 2  |
| 2.5             | Pedestrian and Cyclist Access - BOI condition 34 b (v) ..... 2                                  |
| 2.6             | Maintaining Existing Transport Services - BOI condition 34 b (vi) ..... 3                       |
| 2.7             | Temporary Speed Limits (TSL) - BOI condition 34 b (vii)..... 3                                  |
| 2.8             | Access to & From the Construction Site – BOI condition 34 b (viii)..... 3                       |
| 2.9             | Communications and Stakeholders – BOI condition 34 b (ix)..... 3                                |
| <b>3</b>        | <b>Additional CTMP Considerations ..... 3</b>   |
| 3.1             | Kiwirail NIMTR - CTMP section 2.1.2..... 3  |
| 3.2             | Emergency Action Plan(s) – CTMP section 3.2.3.8 ..... 4   |
| 3.3             | Access to KCDC Owned and Operated Water and Waste Water Assets – CTMP section 3.2.1.1.7 ..... 4 |
| 3.4             | Monitoring, Auditing & Reporting – CTMP sections 3.3 & 3.4 ..... 4                              |
| 3.5             | Complaints – CTMP sections 3.5..... 4   |
|                 | <b>Appendix A – site access point (i.d) ..... 5</b>   |

# 1 INTRODUCTION

This Site Specific Traffic Management Plan (SSTMP) provides the necessary information to demonstrate how the project team plan to avoid or mitigate potential construction traffic effects from activities associated with project-wide site clearance and enabling works activities as outlined in **SSEMP PW1**.

This SSTMP reflects the requirements of the Construction Traffic Management Plan (CTMP) including sections 1.3 (Performance Standards) and section 3.2.1 - specifically the need to interface with TTM on other networks. This plan is also consistent with the requirements set out in the over-arching Construction Environmental Management Plan (CEMP).

This document is intended to be utilised by the construction team to clearly identify any site specific traffic management requirements that must be adhered to prior to, and during works in any given area.

The scope of works detailed within **SSEMP 'Bridge 5 Stage Two'** and for which this SSTMP covers includes works on both the north and south of the Ōtaki River.

There are no additional temporary traffic requirements associated with these works with the already established site access point in place for the southern works from SAP 10 off Otaki Gorge Road (refer to the attached drawing).

In relation to works due to take place on the northern side of the river, an additional site access point is not required from existing SH1. However, coordination between the different access road users (i.e. Winstone Aggregates, Stresscrete and GWRC Flood Protection Team) will require ongoing management to ensure the existing operations, as well as public access is not impacted. See attached drawings which outline the general sequencing of traffic movements around the site during different stages of works.

## 1.1 The SSTMP and TMP Process

This SSTMP provides the necessary information from a project level on how the effects of construction traffic related to the site activities will be avoided or mitigated across the two roading networks in the location of the expressway works i.e. the State Highway Network (NZTA) and the local road network (KDCDC).

Each of the two Road Controlling Authorities (RCA's) has its own processes and procedures for the approvals (TMP's) and implementation of temporary traffic management within their respective networks which is separate to the SSTMP process.

It is recognised that approval / implementation of TMPs associated with this SSTMP will be staged and implemented at differing times over the course of the works. In addition, it is recognised that the TMP's themselves may alter due to both project and surrounding community requirements.

The purpose of this SSTMP is to provide the base (minimum) standard of service / maximum practical level of mitigation to be incorporated into the development of the respective TMP's all the while ensuring that the BOI consent conditions and subsequent CTMP requirements are met during the construction process.

## 2 SSTMP CONSENT CONSIDERATIONS

Reference should also be made to section 3.2 of the CTMP.

### 2.1 Proposed Temporary Traffic Management Measures – BOI condition 34 b (i)

Access to the site will be via one already established access point (SAP 10), covered initially under SSTMP PW1. SAP 10 has the required (CoPTTM) signage and early warning delineation provided by a combination of cones and signage – all in accordance with the respective RCA TMP requirements.

### 2.2 Assessment of delays – BOI condition 34 b (ii)

As there are no closures or detours associated with the implementation and operation of these works, delays to existing traffic flows are not expected.

### 2.3 Detour Routes – BOI condition 34 b (iii)

There are no detours associated with the temporary traffic management measures included within this SSTMP.

### 2.4 Existing Accesses – BOI condition 34 b (iv)

Works carried out under this SSTMP do not affect existing accesses to private or commercial properties.

### 2.5 Pedestrian and Cyclist Access – BOI condition 34 b (v)

Works carried out under this SSTMP will not affect existing pedestrian or cycle routes. Adequate signage will be put in place at river pedestrian access points to notify the public that works are underway. Physical delineation within the river bed is not practicable so signage will be the primary mitigation measure.

## 2.6 Maintaining Existing Transport Services – BOI condition 34 b (vi)

Works carried out under this SSTMP will not affect any existing public transport services and facilities such as bus stops.

## 2.7 Temporary Speed Limits (TSL) – BOI condition 34 b (vii)

There are no TSL's proposed or required in conjunction with the safe operation of SAP 10.

## 2.8 Access to & From the Construction Site – BOI condition 34 b (viii)

The primary objective of SSTMPs is the planning (TMP's), approvals (RCA's) and implementation of Site Access Points (SAP's) to ensure the safe and efficient access to and from site of construction related traffic.

The operating hours of SAP 10 will be in accordance with the proposed hours of work included within the **CNVMP i.e.**

- Monday to Friday 6.30am to 8pm
- Saturday 7.30am to 6pm

Operation outside those hours will be at the approval of the Engineer and in accordance with the provisions of the **CNVMP**.

## 2.9 Communications and Stakeholders – BOI condition 34 b (ix)

Implementation and operation of SAP 10 will be communicated to stakeholders, road users and the community via the methods and processes as included within the project Stakeholder and Communications Management Plan, with particular emphasis on the key groups identified in Section 3.1 of the CTMP as required.

# 3 ADDITIONAL CTMP CONSIDERATIONS

## 3.1 Kiwirail NIMTR – CTMP section 2.1.2

Works carried out under this SSTMP will not interfere or affect the operation of the Kiwirail NIMT Railway or existing at grade carriageway crossings

### **3.2 Emergency Action Plan(s) – CTMP section 3.2.3.8**

All emergency services shall have unimpeded access along all State Highway and local roads 24 hrs. per day.

### **3.3 Access to KCDC Owned and Operated Water and Waste Water Assets – CTMP section 3.2.1.1.7**

Access to existing KCDC water and waste water assets will not be impeded by these works.

### **3.4 Monitoring, Auditing & Reporting – CTMP sections 3.3 & 3.4**

Monitoring, auditing and reporting of the traffic management measures will be carried out in accordance with the CTMP.

### **3.5 Complaints – CTMP sections 3.5**

Feedback including complaints received related to these will be recorded and processed in accordance with the CTMP and the Stakeholder and Communications Management Plan.

## APPENDIX A – SITE ACCESS POINT (I.D) AND LOCATION

| Site Access Point No | Location         |
|----------------------|------------------|
| 10                   | Ōtaki Gorge Road |

SAP 10 (note SAP 9 not relevant to this SSTMP)

|  |                        |                   |
|--|------------------------|-------------------|
| Situation: Site Access Point 9 & 10 - Otaki Gorge Rd<br>Drawing Title: | Drawing No: SAP 9 & 10 | Revision: 1       |
|  |                        | Checked: 17/07/17 |
|  |                        | TMC Approval:     |

**HIGGINS**

# APPENDIX B – GENERAL SEQUENCING OF TRAFFIC MANAGEMENT (NORTH)



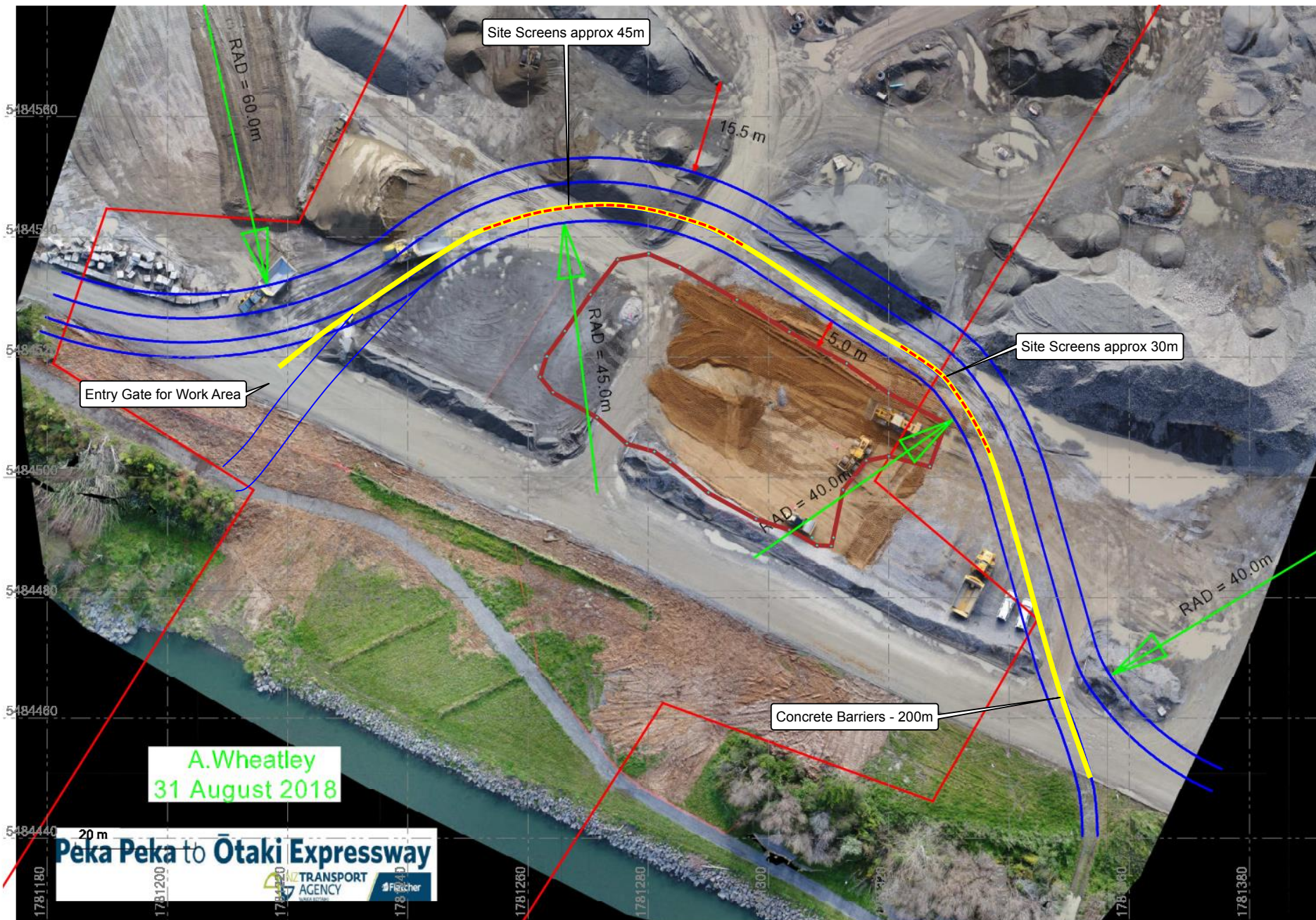

# APPENDIX F – BRIDGE 5 FLOOD MANAGEMENT PLAN



**Document type: Bridge 5, Flood Management Plan**

**Contract Name: Peka Peka to Otaki**

**Area: Bridge 5, Otaki River Bridge**

**Contract No: 730N**

**Document No: FCCL-BG-WPLN-0005**

**Date: 06 AUGUST 2018**

## Document History and Status

| Revisions |         |         |                  |            |                              |
|-----------|---------|---------|------------------|------------|------------------------------|
| Revision  | Status  | Author  | Position         | Date       | Revision Description         |
| A         | Draft   | H Singh | Project Engineer | 12 June 18 | Initial                      |
| B         | Updated | H Singh | Project Engineer | 6 Aug 2018 | Incorporated review comments |

| Approvals |             |               |                         |            |            |
|-----------|-------------|---------------|-------------------------|------------|------------|
| Revision  | Action      | Name          | Position                | Date       | Signature  |
| 1         | Reviewed by | Richard Kemp  | Commercial Manager      | **         | **         |
|           | Reviewed by | Sarah Ropata  | Stakeholder Manager     | **         | **         |
|           | Reviewed by | Red Bacani    | Quality Manager         | **         | **         |
|           | Reviewed by | Alice Naylor  | Environmental Manager   | **         | **         |
|           | Reviewed by | Mike Sarten   | Health & Safety Manager | **         | **         |
|           | Approved by | Steve Findlay | Construction Manager    | 13/08/2018 | S. FINDLAY |

\*\* Approvals as per Work Flow - WF-000097

## Contents

|   |    |
|---|----|
| 1.0 Introduction .....  | 5  |
| Figure 1 Bridge 5 Construction Staging.....   | 5  |
| 2.0 Purpose and objectives .....  | 6  |
| 2.1 Purpose .....   | 6  |
| 2.2 Objective .....   | 6  |
| 2.3 Targets .....   | 6  |
| 3.0 Relevance .....   | 6  |
| 4.0 Environmental requirements.....   | 6  |
| 5.0 Existing environment .....  | 6  |
| 5.1 Otaki River catchment.....  | 7  |
| 5.2 Probabilistic flood level and rainfall data .....                               | 7  |
| Table 1 Rainfall Frequency for McIntosh .....                                       | 7  |
| Table 2 Rainfall Frequency for Kapakapanui.....                                     | 8  |
| Table 3 Rainfall Frequency for Taungata .....                                       | 8  |
| Table 4 Flood Frequency and flows at Pukehinau .....                                | 8  |
| Table 5 Otaki River levels at SH1 Bridge .....                                      | 9  |
| Table 6 Otaki River levels at SH1 Bridge converted into NZVD 2009 datum .....       | 9  |
| 5.3 Otaki catchment travel times (20 year event) .....                              | 10 |
| 6.0 Site Flooding Risk .....  | 11 |
| 7.0 Flooding Risk Management.....   | 11 |
| 7.1 Flood Monitoring .....  | 11 |
| 7.2 Flood Alert Process .....   | 11 |
| Figure 2: Flood Monitoring and Alert Process .....                                  | 12 |
| 7.3 Alert Action Plan – For Rainfall up to 70mm in 24 hours.....                    | 13 |
| Figure 3: Alert action plan initial guide for rainfall up to 70mm in 24 hours ..... | 13 |
| 7.4 Alert Action Plan – For Rainfall <b>exceeding</b> 70mm in 24 hours .....        | 14 |
| 8.0 Emergency Planning for a severe flood event .....                               | 14 |
| Table 7 Emergency Planning Committee Members .....                                  | 15 |
| 8.1 Measures to be implemented during a severe flooding event.....                  | 15 |
| 8.2 Protect and Secure.....   | 15 |
| 8.3 Evacuate.....   | 15 |
| 8.4 Flood recovery .....  | 16 |

9.0 Communication and notification ..... 16  
    Table 8: Relevant contacts in relation to flood emergency ..... 16  
10.0 Compliance Management..... 17  
    Table 9: Measures and responsibility matrix for managing flooding risk..... 17  
11.0 Review and improvement..... 17  
12.0 Appendices..... 18  
    Appendix A Flood Protection Manual..... 18

## 1.0 Introduction

This Construction Flood Management Plan (CFMP) is an extension of the overarching Bridge 5 work plan FCCL-PM-WPLN-0002.

Construction activities for the new Otaki River Bridge (aka Bridge 5) have been staged in two phases. Phase 1 involves construction of foundations, substructure and superstructure of Piers 3 to 9 from the Southern pad and similarly phase 2 will involve construction of the remaining bridge from the Northern bank. As shown below, the original / existing causeway will be further extended up to pier 3 to construct both Piers 3 and 4 from the southern side.

Figure 1 Bridge 5 Construction Staging



As with all rivers, there are times when the Otaki River can flood with the potential to cause flooding risk and damage to the construction area, plant and equipment.

## 2.0 Purpose and objectives

### 2.1 Purpose

The purpose of this CFMP is to describe how the flooding risks will be monitored, minimised and managed so that any significant adverse impacts to personnel, plant and equipment are avoided.

### 2.2 Objective

The key objective of the CFMP is to ensure that the potential and actual effects of the flooding on the construction activities are minimised. To achieve this objective, the following will be undertaken:

- Minimise risks to life, health and safety
- Ensure controls and procedures are implemented during construction activities to avoid, minimise or manage potential adverse impacts to construction works in the event of a flood within or adjacent to the construction pads;
- Ensure measures are implemented to address the requirements of the Site Specific Environmental Management Plan (SSEMP)
- Ensure measures are implemented to comply with all relevant legislation and other requirements

### 2.3 Targets

The following targets have been established for the management of flooding and hydrology impacts during construction of the new bridge:

- Minimise and manage construction impacts on hydrology and flooding from works on the Otaki River and its floodplain; and
- Avoid any adverse impacts to personnel, plant, equipment and project progress

## 3.0 Relevance

This plan is applicable to all construction activities associated with bridge 5, with the highest risk ones being:

- Temporary works i.e. construction of crane pads and river diversion works,
- Permanent works: Foundation, substructure, superstructure and rip-rap installation

## 4.0 Environmental requirements

This plan is to be read in conjunction with Site Specific Environmental Management Plan (SSEMP) FCCL-EV-MPN-0021 for environmental requirements and controls.

## 5.0 Existing environment

This section describes the existing flooding event situation(s) within the Bridge 5 construction area, based on the information contained in Wellington Regional Council's Otaki Floodplain Management Plan.



## 5.1 Otaki River catchment

The Otaki catchment drains over 400km<sup>2</sup> of the western slopes of the Tararua Ranges, and extends from Mt Aston in the south, along the southern ridge line of the Tararuas to Mt Pukematawai in the north.

## 5.2 Probabilistic flood level and rainfall data

Otaki River has a long history of flooding. Tables 1 to 5 below provide details of Otaki catchment’s rainfall frequencies, peak flood levels, and flow rates for a range of return periods.

Table 1 Rainfall Frequency for McIntosh

(2) Rainfall frequency for McIntosh (59201) mm

| Return Period (Years) | Average Annual Probability (%) | Rainfall Depth (mm) for Selected Duration (Hours) |    |    |     |     |     |
|-----------------------|--------------------------------|---|----|----|-----|-----|-----|
|                       |                                | 1   | 2  | 3  | 6   | 12  | 24  |
| 2                     | 50                             | 28  | 47 | 64 | 102 | 141 | 202 |
| 5                     | 20                             | 31  | 54 | 73 | 125 | 182 | 254 |
| 10                    | 10                             | 32  | 57 | 78 | 136 | 210 | 289 |
| 20                    | 5                              | 33  | 59 | 82 | 146 | 236 | 322 |
| 50                    | 2                              | 35  | 61 | 86 | 158 | 271 | 365 |
| 100                   | 1                              | 36  | 62 | 89 | 166 | 297 | 397 |

Table 2 Rainfall Frequency for Kapakapanui

(3) Rainfall frequency for Kapakapanui (59104) mm

| Return Period (Years) | Average Annual Probability (%) | Rainfall Depth (mm) for Selected Duration (Hours) |    |    |     |     |     |
|-----------------------|--------------------------------|---|----|----|-----|-----|-----|
|                       |                                | 1   | 2  | 3  | 6   | 12  | 24  |
| 2                     | 50                             | 19  | 30 | 39 | 57  | 83  | 113 |
| 5                     | 20                             | 25  | 37 | 47 | 70  | 105 | 143 |
| 10                    | 10                             | 29  | 41 | 53 | 78  | 118 | 167 |
| 20                    | 5                              | 32  | 44 | 59 | 86  | 132 | 190 |
| 50                    | 2                              | 37  | 48 | 66 | 96  | 149 | 220 |
| 100                   | 1                              | 41  | 51 | 72 | 103 | 162 | 243 |

Table 3 Rainfall Frequency for Taungata

(4) Rainfall frequency for Taungata (58201) mm

| Return Period (Years) | Average Annual Probability (%) | Rainfall Depth (mm) for Selected Duration (Hours) |    |    |     |     |     |
|-----------------------|--------------------------------|---|----|----|-----|-----|-----|
|                       |                                | 1   | 2  | 3  | 6   | 12  | 24  |
| 2                     | 50                             | 24  | 37 | 48 | 76  | 114 | 145 |
| 5                     | 20                             | 29  | 45 | 59 | 95  | 138 | 190 |
| 10                    | 10                             | 34  | 51 | 65 | 106 | 150 | 220 |
| 20                    | 5                              | 39  | 57 | 71 | 116 | 161 | 249 |
| 50                    | 2                              | 47  | 65 | 78 | 127 | 173 | 286 |
| 100                   | 1                              | 53  | 71 | 83 | 135 | 181 | 314 |

Table 4 Flood Frequency and flows at Pukehinou

Flood Frequencies for Otaki River at Pukehinou (31807) m<sup>3</sup>/s

| Return Period (Years) | Average Annual Probability (%) | Flow (m <sup>3</sup> /s) |
|-----------------------|--------------------------------|--------------------------|
| 2                     | 50                             | 900                      |
| 5                     | 20                             | 1160                     |
| 10                    | 10                             | 1330                     |
| 20                    | 5                              | 1500                     |
| 50                    | 2                              | 1710                     |
| 100                   | 1                              | 1870                     |

Table 5 Otaki River levels at SH1 Bridge

Otaki River levels at SH1 bridge

| SH1 Bridge Level (Right bank) (m) | Reduced Level (m) | Return Period (years) | SH Bridge Flow (cumecs) | Pukehinau Level (m) |
|-----------------------------------|-------------------|-----------------------|-------------------------|---------------------|
| 1.92                              | 12.09             | 1.3                   | 800                     | 5.73                |
| 2.35                              | 12.52             | 2                     | 985                     | 6.19                |
| 2.72                              | 12.89             | 5                     | 1210                    | 6.88                |
| 2.96                              | 13.13             | 10                    | 1370                    | 7.30                |
| 3.22                              | 13.39             | 20                    | 1510                    | 7.64                |
| 3.56                              | 13.73             | 50                    | 1710                    | 8.06                |
| 3.80                              | 13.97             | 100                   | 1860                    | 8.33                |

**NOTE:** Reduced Level (RL) above is expressed in terms of Mean Sea Level (MSL) Wellington (1953) datum. To adjust these levels in terms of NZ Vertical Datum (2009), 0.44m needs to be subtracted. Conversely to adjust levels in NZ Vertical Datum (2009) to be in terms of MSL Wellington Datum, 0.44m needs to be added.

Table 6 Otaki River levels at SH1 Bridge converted into NZVD 2009 datum

| Reduced level (m) in NZVD 2009 | Reduced level (m) in Wellington MSL 1953 | Return Period (years) | SH1 Bridge Flow (cumecs) | Pukehinau Level (m) | Pukehinau Flow (m <sup>3</sup> /s) | average exceedances per year |
|--------------------------------|--|-----------------------|--------------------------|---------------------|------------------------------------|------------------------------|
| 10.5                           | 10.94                                    | -                     | 279                      | 3.800               | 316                                | 9                            |
| 11.0                           | 11.44                                    | -                     | 487                      | 4.600               | 504                                | 3                            |
| 11.5                           | 11.94                                    | -                     | 732                      | 5.500               | 756                                | 1                            |
| 11.65                          | 12.09                                    | 1.3                   | 800                      | 5.73                | -                                  | -                            |
| 12.08                          | 12.52                                    | 2                     | 985                      | 6.19                | -                                  | -                            |
| 12.45                          | 12.89                                    | 5                     | 1210                     | 6.88                | -                                  | -                            |
| 12.69                          | 13.13                                    | 10                    | 1370                     | 7.30                | -                                  | -                            |
| 12.95                          | 13.39                                    | 20                    | 1510                     | 7.64                | -                                  | -                            |
| 13.29                          | 13.73                                    | 50                    | 1710                     | 8.06                | -                                  | -                            |
| 13.53                          | 13.97                                    | 100                   | 1860                     | 8.33                | -                                  | -                            |

5.3 Otaki catchment travel times (20 year event)

This chart presents the shortest expected travel times for a typical five to six hour rainfall event.

3.3.3 Otaki catchment travel times (20 year event)

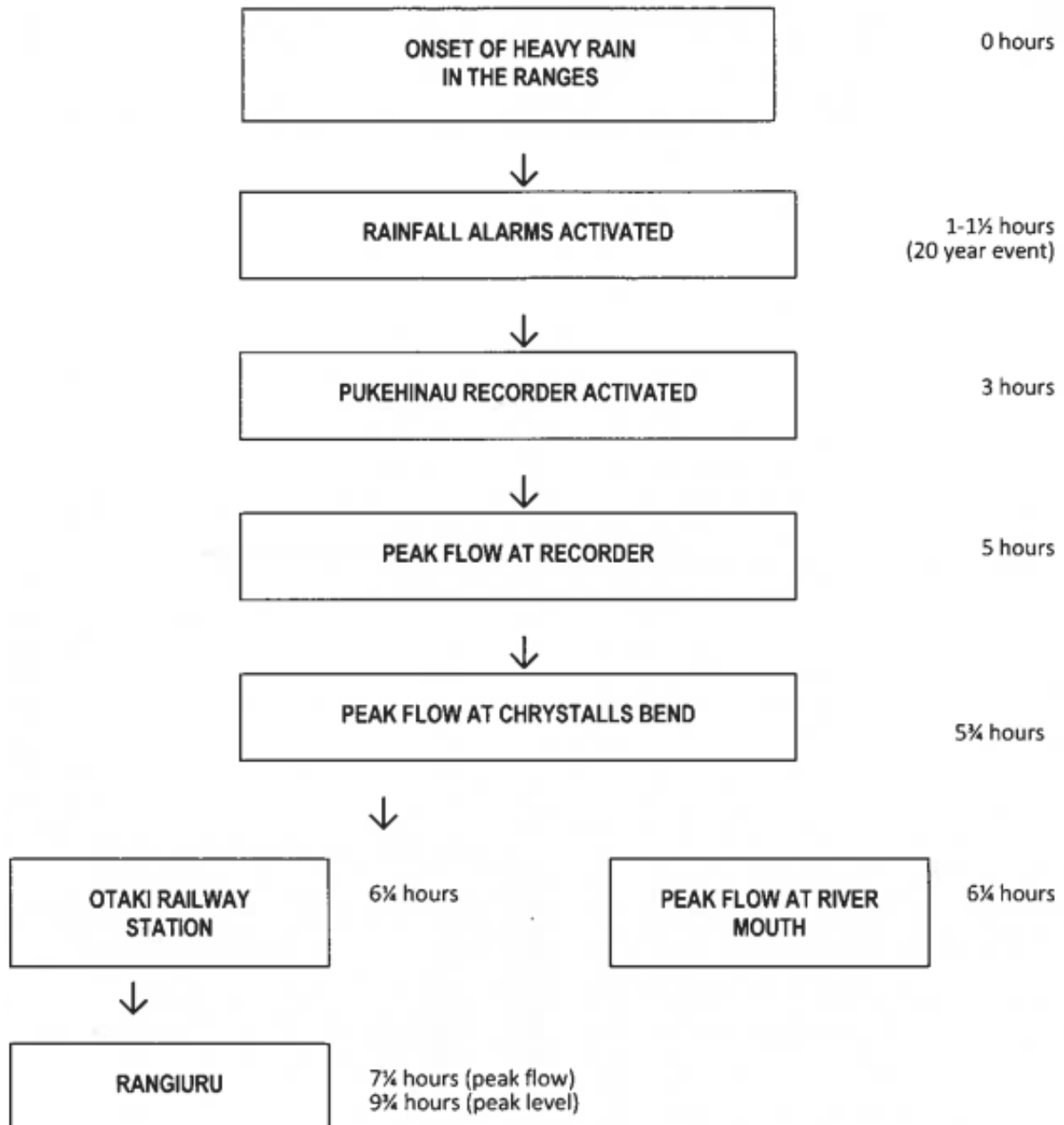

**Note:** This chart presents the **shortest expected travel times** for a typical five to six hour rainfall event. Some floods will rise slower (depending on rainfall temporal distribution).

## 6.0 Site Flooding Risk

The southern construction pad has been constructed to 11.5m RL in NZVD 2009 datum. Otaki River is expected to rise to a RL of 12.09 (in MSL Wellington 1953 datum) i.e. 11.65m in NZVD 2009 at the existing SH1 Bridge during a 1.3 year return period event, which implies the pad is likely to submerge under flood water during an event of a similar or more severe nature. Hence for better management of flooding risks on the Northern side, the temporary staging will be designed to NZVD RL 12.0m or higher.

## 7.0 Flooding Risk Management

This section outlines how the flooding risks will be monitored, minimised and managed so that any significant adverse impacts to personnel, plant and equipment are avoided.

### 7.1 Flood Monitoring

Flood monitoring process will involve self-weather forecast monitoring and day to day liaison with the river authorities as detailed below.

Greater Wellington Regional Council's (GWRC) Flood protection group, whose primary function is to provide an effective flood forecasting and warning service, will be consulted regularly to ascertain if any flood warnings have been issued.

In addition to the alerts provided by GWRC, Fletcher construction will monitor rain forecasts daily to determine whether rainfall in the catchment is predicted to cause elevated river levels at the construction work zones or ancillary facilities.

Information sources to be used are:

- Tararua Forest Park rainfall at <http://www.metservice.com/mountain/tararua-forest-park>
- Rainfall forecast at <http://www.metservice.com/rural/kapiti-horowhenua#!/otaki>
- GWRC flood warning text alert for severe weather warning and river level alarms for Otaki river at Pukehinou station at 4.5m (431m<sup>3</sup>/s) and 5.5m (555m<sup>3</sup>/s)
- Real time data from automated telemetry systems on <http://graphs.gw.govt.nz/>
  - For river level use station: Otaki River at Pukehinou
  - For rainfall use stations: Penn Creek at McIntosh, Sth Waiotauru River at Kapakapanui, and Waitatapia stream at Taungata
- River level readings off monitoring sticks using a dumpy level or a theodolite **from a safe/higher ground, either construction pad or the natural ground**

### 7.2 Flood Alert Process

The process flow chart below will be used to assess when flooding is possible and whether "Flood Watch Alert" needs to be issued. There could be 2 to 3 hours of rain in the upper catchment before this runoff impact (increasing river height and velocity) is actually experienced in the vicinity of the site.

Figure 2: Flood Monitoring and Alert Process

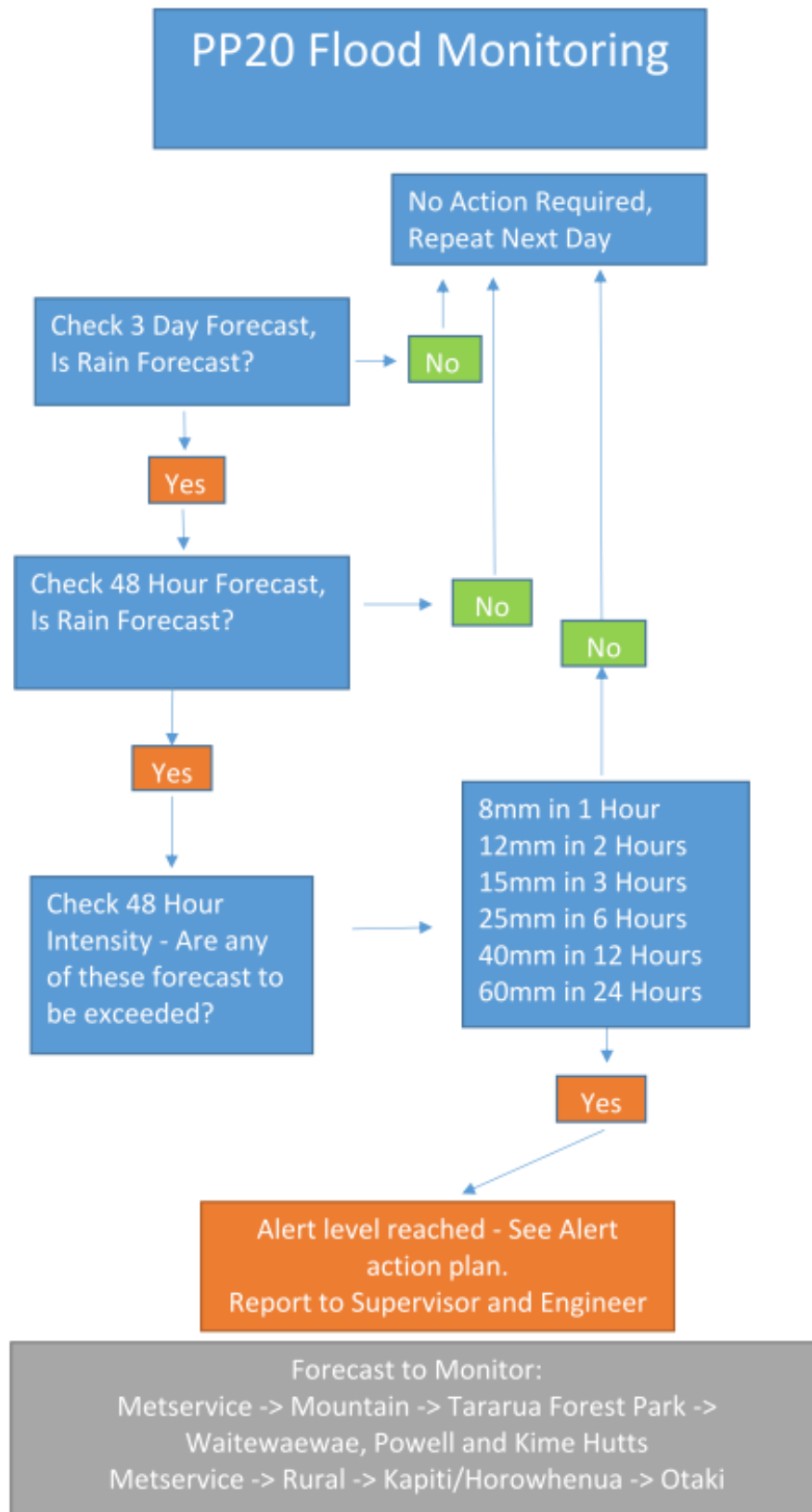

## 7.3 Alert Action Plan – For Rainfall up to 70mm in 24 hours

When on alert, the FCC Engineers or the Construction Supervisor will start monitoring river levels and advise to take necessary actions on a case by case basis depending on the pier location, work activity, current and forecast river RL. Based on top of southern crane pad RL of 11.5m, as an initial guide, the following actions shall be considered as a minimum (refer figure 2 legend below for action details):

Figure 3: Alert action plan initial guide for rainfall up to 70mm in 24 hours

| Location | River RL (m) | Action plan based on forecast river flow rate and RL |           |          |
|----------|--------------|--|-----------|----------|
|          |              | Rising   | Plateaued | Receding |
| Pier 5   | 10.5         |  |           |          |
|          | 11.0         |  |           |          |
| Pier 6   | 10.5         |  |           |          |
|          | 11.0         |  |           |          |
| Pier 7   | 10.5         |  |           |          |
|          | 11.0         |  |           |          |
| Pier 8   | 10.5         |  |           |          |
|          | 11.0         |  |           |          |
| Pier 9   | 10.5         |  |           |          |
|          | 11.0         |  |           |          |
| Pier 1   | 10.5         |  |           |          |
|          | 11.0         |  |           |          |
| Pier 2   | 10.5         |  |           |          |
|          | 11.0         |  |           |          |
| Pier 3   | 10.0         |  |           |          |
|          | 10.5         |  |           |          |
| Pier 4   | 10.0         |  |           |          |
|          | 10.5         |  |           |          |

- Monitor river every half an hour but carry on working
- High risk, relocate staff, plant and equipment to Pier 9 or further south**
- Monitor river every half an hour but can resume work subject to crane pad assessment
- Carry on working

**NOTE:** The suitability of initial guide provided in Figure 2 will be reviewed and updated following the first flood event exceeding River RL of 10.5m and 11.0m respectively.

## 7.4 Alert Action Plan – For Rainfall exceeding 70mm in 24 hours

All heavy plant and equipment will be situated predominantly on higher ground south of Pier 9 and north of Pier 1.

To prepare the site for a potential flood emergency upon the issuing of a “Flood Watch Alert” the following will be considered, as a minimum:

- Inform all site staff well in advance of a predicted flood event and confirm flood emergency procedures;
- Ensure no materials are stockpiled in areas of the concentrated overland flow;
- All dangerous and hazardous goods will be stored at the main compound, outside the extent of a 20-yr ARI flood event, on higher ground south of Pier 9 and north of Pier 1 on NZVD 2009 RL 13.5m or above. In the event a flood greater than the 20-yr ARI is predicted, the dangerous goods is to be removed/relocated from site to a safe and secure location outside the extent of the predicted flood event;
- All plant and equipment, including earthworks plant and cranes, is to be moved and parked in areas outside the 20-year ARI flood extent, or RL 13.5m or higher located behind south abutment, and encircled with a wall of sandbags. It shall be noted that it could take around 1.5 to 2 hours to move all machinery from Pier 4 which is achievable with advance weather monitoring and action alert process set out in this plan;
- Silt curtains or other in-river environmental controls are to be removed to a location outside the 20-yr ARI; and
- Store geofabric (or similar) to place around material stockpiles that cannot be located outside of the 20-year ARI flood extent, to prevent erosion and loss of material;

It should be noted that a “Flood Watch Alert” can be issued for the Otaki River without an actual flood occurring. Therefore, consideration of the actions listed above and the timeframe for securing the work site and moving plant and equipment will be decided by Fletcher Construction on a case-by-case basis depending on the most current information available and advice received from GWRC.

It is anticipated that there will be permanent staff as well as sub-contractors and visitors on site during construction. All site personnel (permanent staff, sub-contractors and visitors) will be briefed on emergency procedures in their project induction and periodically during toolbox talks to ensure they are prepared for a flood event. Should evacuation of the site be ordered, it is essential site personnel on site are familiar with the evacuation procedure and routes.

## 8.0 Emergency Planning for a severe flood event

Apart from flash floods, most other floods allow some warning and preparation time. Being prepared for a flood emergency will help manage the risk and reduce potential loss of life and damage to construction works, equipment, property and the environment. Preventing panic during the emergency can be mitigated through proper education, notification and communication of information to enable well informed decisions to be made and executed during the emergency.

Upon the issuing of a “Flood Watch Alert” following severe rainfall (in excess of 70mm in 24 hours), the Project’s Emergency Planning Committee (EPC) will be mobilised to co-ordinate the preparation of the site, communicate and notify site personnel and GWRC and potentially evacuate the site if deemed necessary. The personnel comprising the EPC are identified in Table 6.



Table 7 Emergency Planning Committee Members

| EPC Member     |  | Project Role                | Discipline: Focus Area                                      |
|----------------|--|-----------------------------|---|
| Steve Findlay  |  | Construction Manager        | Construction: Entire site                                   |
| Craig Service  |  | Structures Manager          | Construction: Entire site                                   |
| Glenn Boyer    |  | Bridge Supervisor           | Site Personnel, Plant, equipment and materials: Entire site |
| Simon Fifield  |  | Construction Superintendent | Site Personnel, Plant, equipment and materials: Entire site |
| Michael Sarten |  | Health and Safety Manager   | Site Personnel: Entire site                                 |
| Alice Naylor   |  | Environmental Manager       | Environment: Entire site                                    |
| Ethan Coleman  |  | Site Engineer               | Site Personnel, Plant, equipment and materials: Entire site |
| Harry Singh    |  | Project Engineer            | Site Personnel, Plant, equipment and materials: Entire site |

### 8.1 Measures to be implemented during a severe flooding event

During an emergency, KCDC is responsible for co-ordinating disaster relief and planning on the Otaki floodplain. Upon the issuing of a “Severe weather warning or Flood Warning”, Fletcher Construction will continuously monitor Metservice website and GWRC Flood Warning Service. Fletcher Construction will also coordinate with GWRC’s Flood Protection Group who is the lead agency for assessing available information, make predictions, and provide warnings to appropriate agencies and other affected parties.

### 8.2 Protect and Secure

Upon the issuing of a “Severe Flood Warning” the following actions are advised if they were unable to be carried out/completed prior to a predicted flood event:

- Secure all items that may become hazardous and cause damage if moved by flood water;
- Relocate chemicals that react with water to give off heat or form explosive or toxic gases and poisons to the highest level. Include any substances that could contaminate flood waters; and
- Tie down timber, drums and other loose, buoyant items to prevent them from being carried away by flood water or battered against other items or structures.

### 8.3 Evacuate

The decision by the EPC to advise or direct people to evacuate should be considered whenever there is a potential need to move people to a safer place. The decision process of the EPC should take into consideration where an evacuation has already been instigated, whether by GWRC Flood Protection group or Civil Defence. During a flood event, the Bridge lodge will serve as an emergency assembly

area where workers will gather before an evacuation order is issued. **Please refer Appendix B for details.**

Once a decision to evacuate is made, site personnel will be immediately notified of the decision and provided advice on the withdrawal process, including any actions or evacuation routes to follow.

Withdrawal is to be an orderly, potentially phased, removal from the project site via the site access points. The movements of all site personnel are to be recorded in a register. Site personnel will be encouraged to use their own method of transport to evacuate the site.

## 8.4 Flood recovery

A flood event during the construction phase could cause considerable damage to the work area and the environment. If the site is properly prepared for the flood event, then damage could be minimised. The following list of actions should be considered when returning to site:

- Wait until GWRC and Civil Defence have declared the area safe before entering;
- Access roads to site may have been damaged during the flood event so drive carefully and approach the site safely;
- Do not turn power back on until all electrical equipment on site has been checked and certified by a qualified electrician;
- Check the integrity of all temporary works and construction pads;
- Check to see if any equipment has been moved by flood waters and relocate equipment back to a safe position/location;
- Check material stockpiles for erosion and losses;
- Prepare an incident report on the flood event. Include information on how the site was evacuated and document the resulting flood depths and damage to the site; and
- EPC to re-open site only when it is deemed safe to continue work. Only once the flood has receded and the site has been re-opened should in-river environmental controls, equipment or platforms be re-established.

## 9.0 Communication and notification

Timely and accurate warning information is vital during emergencies and is integral to minimising panic and ensuring suitable actions can be taken to minimise risk to life and property.

When heavy rainfall is being experienced and throughout the implementation of this CFMP, communication and consultation with the organisations stipulated in Table 7 must be undertaken continuously.

**Table 8: Relevant contacts in relation to flood emergency**

| Organisation Contact        | Number                         | Website   |
|-----------------------------|--------------------------------|---|
| Emergency Services          | 111                            |   |
| KCDC                        | 04 296 4700 or<br>0800 486 486 | <a href="https://www.kapiticoast.govt.nz/Our-District/cdem/floods/">https://www.kapiticoast.govt.nz/Our-District/cdem/floods/</a> |
| Metservice                  | -                              | <a href="http://www.metservice.com/rural/kapiti-horowhenua#!/otaki">http://www.metservice.com/rural/kapiti-horowhenua#!/otaki</a> |
| GWRC Flood Protection Group |                                |   |
| FCC Project Manager         | 027 405 3615                   |   |

|  |              |  |
|--|--------------|--|
| Andrew Goldie                                    |              |  |
| FCC Construction Manager<br>Steve Findlay        | 029 770 3128 |  |
| FCC Health and Safety Manager<br>Michael Sarten  | 027 577 9379 |  |
| FCC Environmental Manager<br>Alice Naylor        | 027 2976055  |  |
| FCC Structures Manager<br>Craig Service          | 027 809 3598 |  |
| FCC Construction Superintendent<br>Simon Fifield | 027 209 2295 |  |
| FCC Bridge Supervisor<br>Glenn Boyer             | 027 2765496  |  |

## 10.0 Compliance Management

A range of monitoring and action planning requirements are identified in the various sections above to minimise or manage the implications on health or safety, environment and construction in the event of a flood. Measures and personnel responsible to minimise flooding impacts are outlined in Table 8.

Table 9: Measures and responsibility matrix for managing flooding risk

| Item | Measure/Requirement                      | Where addressed      | When to implement   | Responsibility                        |
|------|--|----------------------|---|---------------------------------------|
| 1    | Rainfall forecast monitoring             | Section 7.1          | Daily   | Ethan Coleman/Harry Singh             |
| 2    | River level monitoring                   | Section 7.1          | Daily   |                                       |
| 3    | Flood forecasting                        | Section 7.1          | Severe weather events and when telemetry alarms for agreed river levels are activated | GWRC – Flood protection group         |
| 4    | Alert action planning and implementation | Sections 7.3 and 7.4 | When on alert and as necessary on a case by case basis                                | Ethan Coleman/Harry Singh/Glenn Boyer |
| 5    | Emergency planning for a sever event     | Sections 8 and 9     | When severe flood warning is issued or a flash flooding event                         |                                       |

## 11.0 Review and improvement

Following the recent flood event of 7 and 8 July, 2018, the assembly and relocation area for personnel and plant has been set to Pier 9 and higher ground further south. This area is at ~RL12.5m (higher than 5yr RP flood) and it is ~50m south of the floodway.

## 12.0 Appendices

### Appendix A Flood Protection Manual

### 3.3 Otaki catchment

#### 3.3.1 Rainfall frequencies

##### (1) Rainfall frequency for Oriwa (57302) mm

| Return Period (Years) | Average Annual Probability (%) | Rainfall Depth (mm) for Selected Duration (Hours) |     |     |     |     |     |
|-----------------------|--------------------------------|---|-----|-----|-----|-----|-----|
|                       |                                | 1   | 2   | 3   | 6   | 12  | 24  |
| 2                     | 50                             | 34  | 55  | 74  | 115 | 175 | 236 |
| 5                     | 20                             | 44  | 70  | 92  | 144 | 214 | 299 |
| 10                    | 10                             | 51  | 79  | 104 | 163 | 236 | 335 |
| 20                    | 5                              | 58  | 88  | 115 | 181 | 255 | 367 |
| 50                    | 2                              | 67  | 100 | 130 | 204 | 278 | 406 |
| 100                   | 1                              | 74  | 108 | 141 | 221 | 293 | 433 |

##### (2) Rainfall frequency for McIntosh (59201) mm

| Return Period (Years) | Average Annual Probability (%) | Rainfall Depth (mm) for Selected Duration (Hours) |    |    |     |     |     |
|-----------------------|--------------------------------|---|----|----|-----|-----|-----|
|                       |                                | 1   | 2  | 3  | 6   | 12  | 24  |
| 2                     | 50                             | 28  | 47 | 64 | 102 | 141 | 202 |
| 5                     | 20                             | 31  | 54 | 73 | 125 | 182 | 254 |
| 10                    | 10                             | 32  | 57 | 78 | 136 | 210 | 289 |
| 20                    | 5                              | 33  | 59 | 82 | 146 | 236 | 322 |
| 50                    | 2                              | 35  | 61 | 86 | 158 | 271 | 365 |
| 100                   | 1                              | 36  | 62 | 89 | 166 | 297 | 397 |

##### (3) Rainfall frequency for Kapakapanui (59104) mm

| Return Period (Years) | Average Annual Probability (%) | Rainfall Depth (mm) for Selected Duration (Hours) |    |    |     |     |     |
|-----------------------|--------------------------------|---|----|----|-----|-----|-----|
|                       |                                | 1   | 2  | 3  | 6   | 12  | 24  |
| 2                     | 50                             | 19  | 30 | 39 | 57  | 83  | 113 |
| 5                     | 20                             | 25  | 37 | 47 | 70  | 105 | 143 |
| 10                    | 10                             | 29  | 41 | 53 | 78  | 118 | 167 |
| 20                    | 5                              | 32  | 44 | 59 | 86  | 132 | 190 |
| 50                    | 2                              | 37  | 48 | 66 | 96  | 149 | 220 |
| 100                   | 1                              | 41  | 51 | 72 | 103 | 162 | 243 |

**(4) Rainfall frequency for Taungata (58201) mm**

| Return Period (Years) | Average Annual Probability (%) | Rainfall Depth (mm) for Selected Duration (Hours) |    |    |     |     |     |
|-----------------------|--------------------------------|---|----|----|-----|-----|-----|
|                       |                                | 1   | 2  | 3  | 6   | 12  | 24  |
| 2                     | 50                             | 24  | 37 | 48 | 76  | 114 | 145 |
| 5                     | 20                             | 29  | 45 | 59 | 95  | 138 | 190 |
| 10                    | 10                             | 34  | 51 | 65 | 106 | 150 | 220 |
| 20                    | 5                              | 39  | 57 | 71 | 116 | 161 | 249 |
| 50                    | 2                              | 47  | 65 | 78 | 127 | 173 | 286 |
| 100                   | 1                              | 53  | 71 | 83 | 135 | 181 | 314 |

**3.3.2 Flood Frequencies for Otaki River at Pukehinau (31807) m<sup>3</sup>/s**

| Return Period (Years) | Average Annual Probability (%) | Flow (m <sup>3</sup> /s) |
|-----------------------|--------------------------------|--------------------------|
| 2                     | 50                             | 900                      |
| 5                     | 20                             | 1160                     |
| 10                    | 10                             | 1330                     |
| 20                    | 5                              | 1500                     |
| 50                    | 2                              | 1710                     |
| 100                   | 1                              | 1870                     |

3.3.3 Otaki catchment travel times (20 year event)

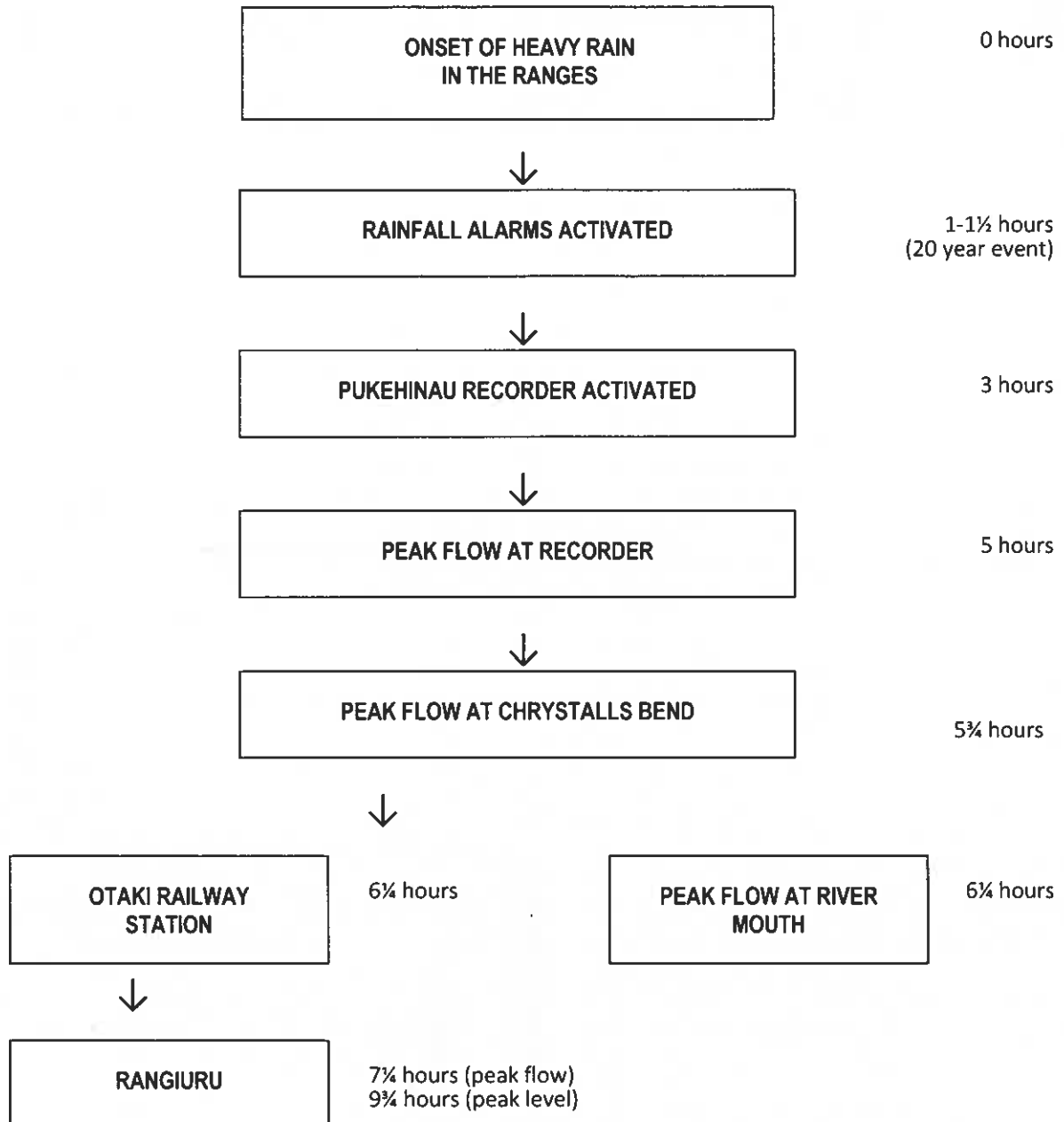

**Note:** This chart presents the **shortest expected travel times** for a typical five to six hour rainfall event. Some floods will rise slower (depending on rainfall temporal distribution).

### 3.3.4 Otaki River rating curve

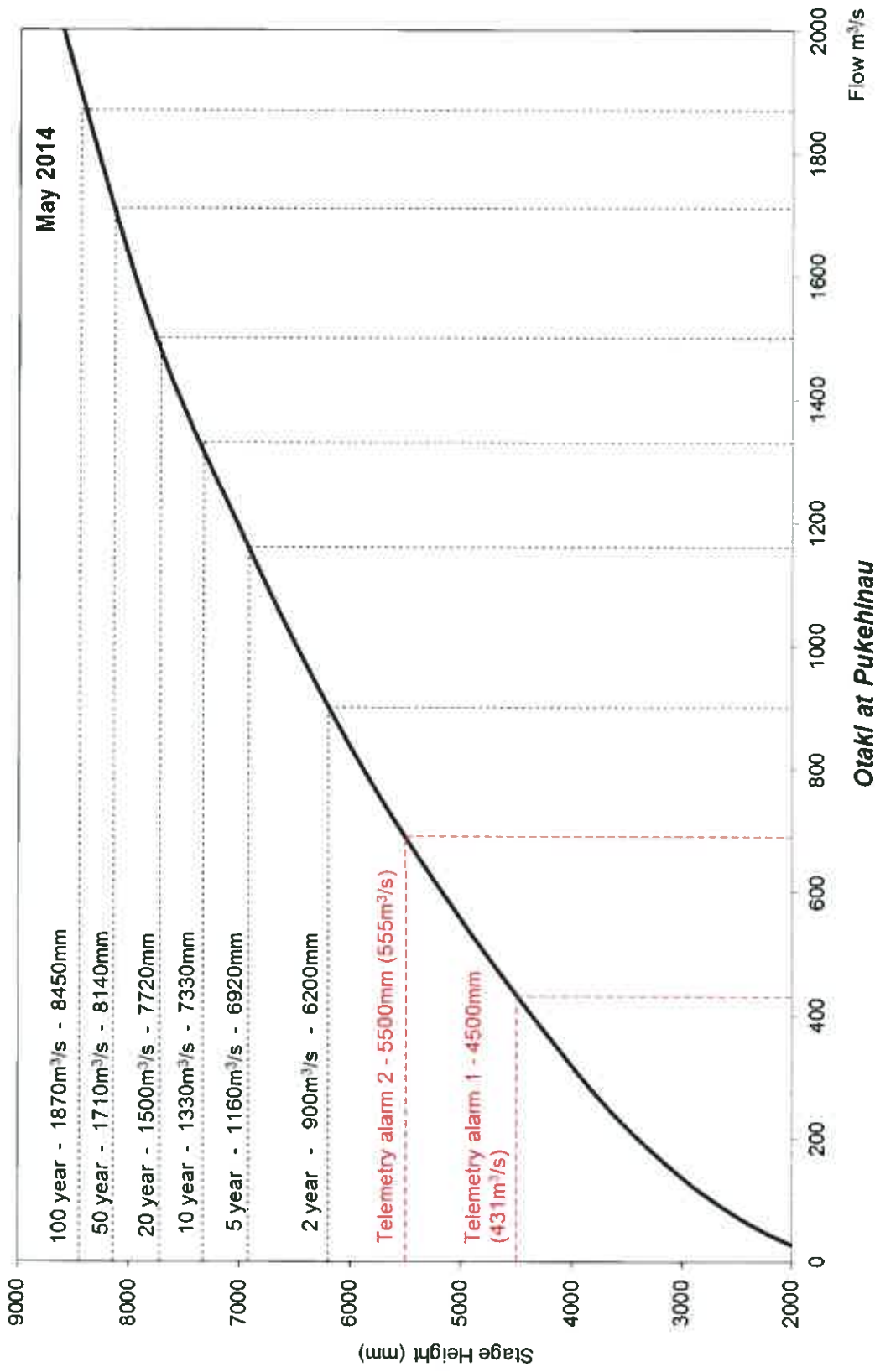



## 3.3.5 Otaki River critical river levels (Kapiti Ops to advise these contacts)

| Gauge Height (m) | Return Period (years) | Flow (m <sup>3</sup> /sec) | Description              | Consequence                 |
|------------------|-----------------------|----------------------------|--------------------------|-----------------------------|
| 5.5 (approx)     | Q1                    | 555                        | Hughes and Wallace Farms | Advise to move stock        |
| 6.2              | Q2                    | 900                        | Barretts                 | Advise to move stock        |
| 6.2              | Q2                    | 900                        | Waimanu Culvert          | Access up haul road blocked |
| 6.92             | Q5                    | 1160                       | River Mouth              | Check Katihiku LB and mouth |
| 7.33             | Q10                   | 1330                       | Lutz Farms Ltd           | Advise to move stock        |
| 7.52?            | Q15                   | 1400                       | All LB landowners        | Advise to move stock        |
| 7.52?            | Q15                   | 1400                       | Ramsbottom RB            | Close Chrystalls floodgate  |

## 3.3.6 Otaki River levels at SH1 bridge

| SH1 Bridge Level (Right bank) (m) | Reduced Level (m) | Return Period (years) | SH Bridge Flow (cumecs) | Pukehinau Level (m) |
|-----------------------------------|-------------------|-----------------------|-------------------------|---------------------|
| 1.92                              | 12.09             | 1.3                   | 800                     | 5.73                |
| 2.35                              | 12.52             | 2                     | 985                     | 6.19                |
| 2.72                              | 12.89             | 5                     | 1210                    | 6.88                |
| 2.96                              | 13.13             | 10                    | 1370                    | 7.30                |
| 3.22                              | 13.39             | 20                    | 1510                    | 7.64                |
| 3.56                              | 13.73             | 50                    | 1710                    | 8.06                |
| 3.80                              | 13.97             | 100                   | 1860                    | 8.33                |

Source: Figures established 17 November 1994.

**Refer to Appendix 6 – Kapiti Ops Landowner Warning Lists**



## Appendix B EVACUATION ROUTE AND ASSEMBLY AREA

