Site Specific Environmental Management Plan

– Peka Peka to Ōtaki Project

BR04: Rahui Road Underpass (Bridge 4)

FCCL-EV-MPN-0034

July 2018 – Revision C.1

Contents

Authorisation and Revision Record (GWRC)	iv
Certification Record.....	iv
Authorisation and Revision Record (KCDC).....	v
Certification Record.....	v
1 Introduction.....	6
1.1 Location of Works	6
1.2 Programme	7
2 Plan implementation.....	8
2.1 Responsibilities	8
2.2 SSEMP Changes.....	11
3 General Site Management.....	12
3.1 Site Access.....	12
3.2 Site Establishment.....	12
3.3 Construction Plant	12
3.4 Pre-works Requirements	13
3.5 Water Supply.....	14
4 Works Methodology.....	14
4.1 Watercourse Decommissioning	14
4.2 Culvert Construction	14
4.2.1 Stage One: Temporary stream diversion	15
4.2.2 Stage Two: Culvert commissioning	16
4.3 Temporary Stream Diversion Design	16
4.4 Temporary Culvert Crossing.....	17
4.5 Permanent Diversion Design.....	17
4.5.1 Channel Shape and Erosion Protection.....	17
4.5.2 Fish Passage	17

4.6	Bridge Construction	18
4.6.1	MSE Walls.....	18
4.6.2	Abutment Beams	18
4.6.3	Beams and Bearing Placement	18
4.6.4	Deck Construction.....	19
4.6.5	Continuation of MSE wall, settlement slab construction and abutment backfill	19
4.6.6	Barrier construction	19
4.7	Disposal Sites	20
4.8	Dewatering.....	20
5	Environmental requirements.....	20
5.1	Contaminated Land.....	20
5.2	Erosion and Sediment Control	22
5.2.1	Installation and Decommissioning	22
5.3	Ecological Requirements.....	23
5.3.1	Terrestrial Ecology	23
5.3.2	Aquatic Ecology.....	23
5.4	Water Quality Monitoring.....	24
5.5	Cultural Monitoring.....	24
5.6	Archaeology	25
5.7	Noise and Vibration	25
5.7.1	Pre-condition building surveys.....	27
5.8	Air Quality	27
6	Traffic	27
	Appendix A – SSEMP authors.....	28
	Appendix B – Consultation Record	29
	Appendix C – Drawings	30
	Works Methodology / Layout Plan	31
	Environmental Constraints Drawings	32

Construction Drawings..... 33

Appendix D – Stormwater Information 34

Appendix E: Programme 35

Appendix F: SSTMP 36

Appendix G: Abstract from EMP – Fish Migration Management 37

Appendix H: Asbestos Management Plan 38

AUTHORISATION AND REVISION RECORD (GWRC)

Revision	Status	Author	Date	Description
A	Draft	Alice Naylor	06/06/18	For Review
A.1	Draft	Alice Naylor	08/06/18	For Review
B	Draft	Alice Naylor	3/7/18	For Review
B.1	Draft	Alice Naylor / Sevi Hartley	17/07/2018	For Review
C	Final	Alice Naylor	03/08/18	For Certification
C.1	Updated	Alice Naylor	18/12/18	Permanent Details Included

Certification Record

Revision	Action	Name	Position	Date	Signature
	Approved by:	Richard Percy	Project Leader	5/2/19	
	On behalf of GWRC:				

AUTHORISATION AND REVISION RECORD (KCDC)

Revision	Status	Author	Date	Description
A	Draft	Alice Naylor	06/06/18	For Review
A.1	Draft	Alice Naylor	08/06/18	For Review
B	Draft	Alice Naylor	3/7/18	For Review
B.1	Draft	Alice Naylor / Sevi Hartley	17/07/2018	For Review
C	Final	Alice Naylor	03/08/18	For Certification
C.1	Updated	Alice Naylor	18/12/18	Permanent Details Included

Certification Record

Revision	Action	Name	Position	Date	Signature
	Approved by:				
	On behalf of KCDC:				

CERTIFIED

 VISAYA SOMA
 Resource Consents & Compliance Manager
 Kapiti Coast District Council
 DATE: 19/12/2018

1 INTRODUCTION

This Site Specific Environmental Management Plan (SSEMP) provides the necessary information to demonstrate how the project team plan to avoid or mitigate potential adverse environmental effects relating to construction of the Peka Peka to Ōtaki Expressway.

This document covers works required to construct the Rahui Road Underpass (Bridge 4). Rahui Road provides a link between Ōtaki township and the residential areas and school to the east. Bridge 4 will carry the realigned Rahui Road over the new Expressway, rail corridor and shared path. The bridge will include a footpath on its northern side and a shared path on its southern side. Prior to bridge construction, the Mangapouri Stream (located immediately to the north of Bridge 4) will be temporarily diverted to allow for the construction of two permanent culverts within the existing stream alignment.

This SSEMP reflects the requirements of the Construction Environmental Management Plan (CEMP) and its appendices, and is intended to be utilised by the construction team to clearly identify any site specific environmental requirements that must be adhered to prior to, and during works. A suite of over-arching environmental management plans have been drawn from to inform the contents of this SSEMP. All works will be carried out in general accordance with these management plans.

Works are not to commence on site until certification of this SSEMP has been confirmed in writing by Kapiti Coast District Council (KCDC) and Greater Wellington Regional Council (GWRC).

1.1 Location of Works

Bridge 4 (chainage 2070) is located to the north of the existing road alignment and to the west of the existing NIMT rail line. The existing rail line passes through the location of the bridge 4 eastern abutment which is being realigned to pass under the bridge. The site is generally a flat residential area with services running along Rahui Road, a number of which have now been realigned. The existing State Highway is approximately 150m north-west of the proposed underpass.

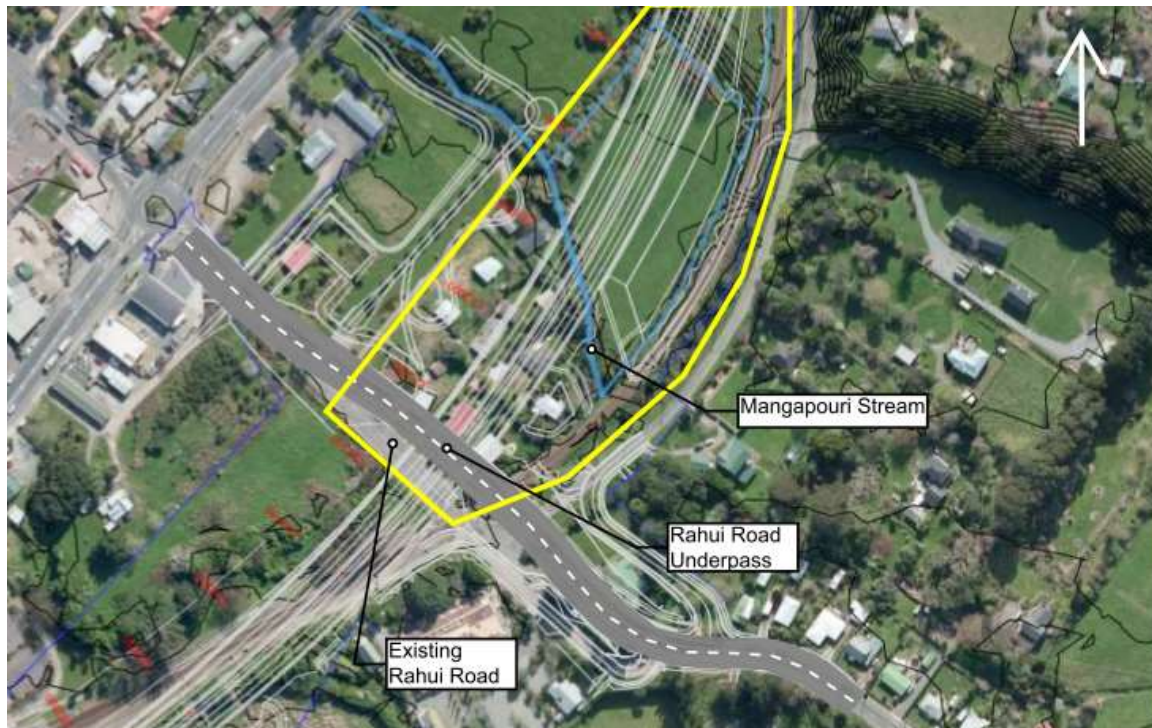

Figure 1: General location of works outlined in yellow

1.2 Programme

Works are expected to commence in July 2018 and be completed by mid-late 2019. A detailed programme is included as Appendix D.

2 PLAN IMPLEMENTATION

2.1 Responsibilities

The following provides a summary of responsibilities relevant to the planning and implementation of this SSEMP.

Table 2: Roles and responsibilities

Role	Person	Contact Details	Responsibilities
Construction Manager	Steve Findlay	stevef@fcc.co.nz	<ul style="list-style-type: none"> Ensures there is a system in place so that construction works do not proceed until required environmental sign-offs are completed. Overviews systems and processes to ensure consent requirements are captured for construction works. Ensures adequate resources are provided to ensure environmental issues are appropriately managed. Reviews environmental incidents and complaints with the Environmental Manager and acts to address issues where needed. Reviews and monitors construction work methods to ensure compliance with RMA conditions
Environmental Manager	Alice Naylor	A.Naylor@Higgins.co.nz	<ul style="list-style-type: none"> Develops, implements and reviews environmental management systems and environmental management plans. Coordinates all environmental auditing functions and ensures relevant records are maintained. Responds to and investigates all environmental complaints, issues or incidents. Coordinates the SSEMP implementation process and pre-works requirements to ensure that environmental requirements are adhered to. Provides training and briefings to site staff to ensure that there is sufficient

			<p>knowledge of environmental requirements in the field.</p> <ul style="list-style-type: none"> • Acts as the primary point of communication between regulatory bodies and the project. • Coordinates a team of experts in specialist disciplines such as contaminated land, ecology, groundwater, noise and vibration. • Communicates environmentally sensitive areas to the construction team.
Environmental Coordinator	Sevasti Hartley	sevastih@fcc.co.nz	<ul style="list-style-type: none"> • Supports the Environmental Manager and provides leadership to ensure all staff comply with environmental management systems. • Provides support in the formation of SSEMPs. • Undertakes as-built of environmental controls. • Undertakes regular site inspections and audits. • Coordinates all site monitoring including but not limited to groundwater, water quality, ecological, dust, noise, and vibration monitoring. • Manages maintenance and monitoring of Chemical Treatment Systems (if used). • Ensures spill kits are available and stocked and provides training on equipment use. • Conducts regular site inspections of erosion and sediment control devices and co-ordinates maintenance where necessary. • Monitors site controls during rain storms. • Trains staff in site specific environmental procedures.
Stakeholder & Communications Manager	Ed Breese	ebreese@tonkintaylor.co.nz	<ul style="list-style-type: none"> • Organises, co-ordinates and facilitates engagement with affected property holders and community prior to and during construction.

			<ul style="list-style-type: none"> • Works in partnership with Environmental Manager on engagement and construction activities in accordance with RMA conditions
Site Superintendent / Supervisors / Foreman	Simon Fifield	SimonF@fcc.co.nz	<ul style="list-style-type: none"> • Provides leadership to the site construction team. • Ensures environmental controls including erosion and sediment control works are protected and maintained on a day to day basis. • Ensures that the SSEMPs and Archaeological Authority requirements are implemented appropriately by the construction team. • Maintains contactability 24/7 during construction and has authority to initiate immediate response actions. • Reports all environmental incidents, compliance issues and complaints to the Environmental Manager. • Reviews the need to use a water cart or sprinklers to control dust.
Project Engineers	Richard Rakovics (Civil) Craig Service (Structural)	RichardR@fcc.co.nz CraigS@fcc.co.nz	<ul style="list-style-type: none"> • Responsible for ensuring environmental controls and erosion and sediment control works are installed and modified as appropriate for each stage of construction. • Develop, implements and monitors construction methods and environmental protection measures to ensure compliance with the SSEMPs. • Demonstrate understanding of major environmental and community issues and environmentally sensitive areas. • Coordinate environmental interfaces with subcontractors and suppliers. • Reports all environmental incidents, compliance issues and complaints to the Environmental Manager.

Specialist support (contaminated land, ecology, noise and vibration)	Dean Miller (Principal Ecologist)	DCMiller@tonkintaylor.co.nz	<ul style="list-style-type: none"> • Provide expert advice to the Environmental Manager and Environmental Coordinator regarding specific site requirements. • Submits reports to the Environmental Manager to fulfil requirements of consents relevant to their field. • Briefs the construction team of site specific requirements for environmentally 'sensitive areas'.
Iwi	Te Waari Carkeek (Ngā Hapū o Ōtaki Kiarahi)	TeWaariC@fcc.co.nz	<ul style="list-style-type: none"> • Provide input into project documentation such as management plans, design processes, planning documents. • Reviews permits to work and coordinates the level of involvement of kaitiaki in site activities • Coordinates all aspects of iwi monitoring. • Key point of contact for Ngā Hapū o Ōtaki.
	Caleb Royal (Ngā Hapū o Ōtaki Consents Processing Officer)		<ul style="list-style-type: none"> • Reviews consent applications and coordinates cultural monitoring activities. • Provides specialist advice to Ngā Hapū o Ōtaki
Iwi	Muaupoko Tribal Authority		<ul style="list-style-type: none"> • Point of contact for any archaeological discoveries in accordance with the agreed accidental discovery protocols and MTA agreement.

2.2 SSEMP Changes

In the event that changes in works scope or methodology are required, changes may need to be made to this document in accordance with resource Consent Condition's DC.18B and / or G.21A. Any 'major'

changes will be submitted to the respective Manager for certification at least 5 working days prior to implementation of that change.

In accordance with Condition G.21A, a 'minor change' may be submitted to the Manager for certification at least 2 working days prior to implementation of that change, unless an alternative process of approving a 'minor change' is agreed to by the Manager, Greater Wellington Regional Council.

3 GENERAL SITE MANAGEMENT

3.1 Site Access

Access to the site will be via Rahui Road (approved SAP-11) or from the Bridge 3 site via the Pare-o-matangi Reserve. Access from Rahui Road throughout construction will not impede local road stormwater.

The access/egress points will be stabilised using clean aggregate or sealed to avoid any construction related material leaving the site. Any migration of material from the site onto the local road or footpath will be removed immediately.

3.2 Site Establishment

A site compound is already established on Rahui Road which will continue to be the allocated area for parking, sign-in sheds, and storage of miscellaneous materials (refer to Appendix C 'Methodology / Layout drawings for indicative laydown areas). The site will be maintained in a tidy state with redundant materials removed off-site once no longer required.

3.3 Construction Plant

The plant items to be used are generally as follows:

Earthworks / culvert construction:

- 6 – 20T excavators
- Concrete trucks
- Concrete pumps
- 50T crane
- Truck and trailers for deliveries
- Water cart as required
- Light vehicles

Bridge Works:

- 350T crane x 2
- 20T excavator

- Concrete pump
- 30T crane
- Franner crane
- Merlo
- Hiab
- Light vehicles
- Drill rig (soil nails)
- Trucks

Plant will remain outside of watercourses at all times during the works and where practicable, refrain from working within 10m of a live watercourse to minimise any risk of causing bank instability or spills to the receiving environment.

All plant is required to be inspected prior to commencing works and during construction activities at regular intervals. Unwanted vegetation, seeds or contaminants will be cleared prior to plant entering the site to avoid the introduction or spread of weeds or pest species.

Plant inspections will be recorded on daily plant inspection forms to demonstrate that all plant used on this project are in good working order and have been cleared of unwanted weeds and pest species. Any faulty equipment will be stood down until the necessary repairs are carried out and the given plant is fit for purpose.

Spill control kits will be available on site in areas where heavy machine is working. Refuelling activities will take place using a mini-tanker at least 10m away from any watercourse to prevent additional risk of spillage to water.

3.4 Pre-works Requirements

Prior to works commencing on site the following mitigation measures will be implemented to avoid or minimise adverse environmental effects:

- Site specific information, including environmental constraints and requirements, will be discussed at the relevant pre-construction site meetings with input from specialists as required.
- Prior to works commencing in this area, the project surveyors will use GPS to identify the extent of works. The works area will be clearly marked-out with regular input from the survey team throughout works as required.
- Areas identified as 'retained vegetation' as per the approved vegetation retention plans will be clearly delineated using physical markers on site.
- Environmental requirements for any given area will be noted on each project 'Permit to Work'. These permits are required for any activity on site and must be in place and signed off by the environmental team prior to works commencement.
- Signage and safety fencing will be erected to clearly discourage the public from entering the site. Regular updates will be provided to the community regarding upcoming works and changes to works sequencing.

3.5 Water Supply

Water may be required to prevent dust discharge from site during works. Water required for these works will be collected from off-site.

Any water supply bores required on site must be constructed in accordance with BC.1 – 4 with any water take done so in accordance with GT. 4-7.

4 WORKS METHODOLOGY

Bridge 4 comprises a single span steel-concrete composite bridge deck. The bridge superstructure consists of a configuration of 2050mm deep steel I-girders which are tied together by a cast in situ concrete deck slab and backwall. The superstructure is supported on bearings that sit on reinforced concrete bankseats.

Prior to commencing construction of Bridge 4, the Mangapouri Stream first needs to be temporarily diverted to allow construction of two Culverts (9 & 10) within the existing stream alignment. The general sequencing and works methodology for works will be as follows:

4.1 Watercourse Decommissioning

An unnamed watercourse currently runs through the Expressway alignment footprint and restricts access from the north. This watercourse will be decommissioned once the required fish salvage and relocation procedures are complete (refer to Section 5.3.2 and Appendix C drawings).

4.2 Culvert Construction

Two permanent culverts are to be constructed in the earlier stages of Bridge 4 construction:

- Mangapouri Stream – main alignment (Culvert 9)
- Mangapouri Stream – rail (Culvert 10)

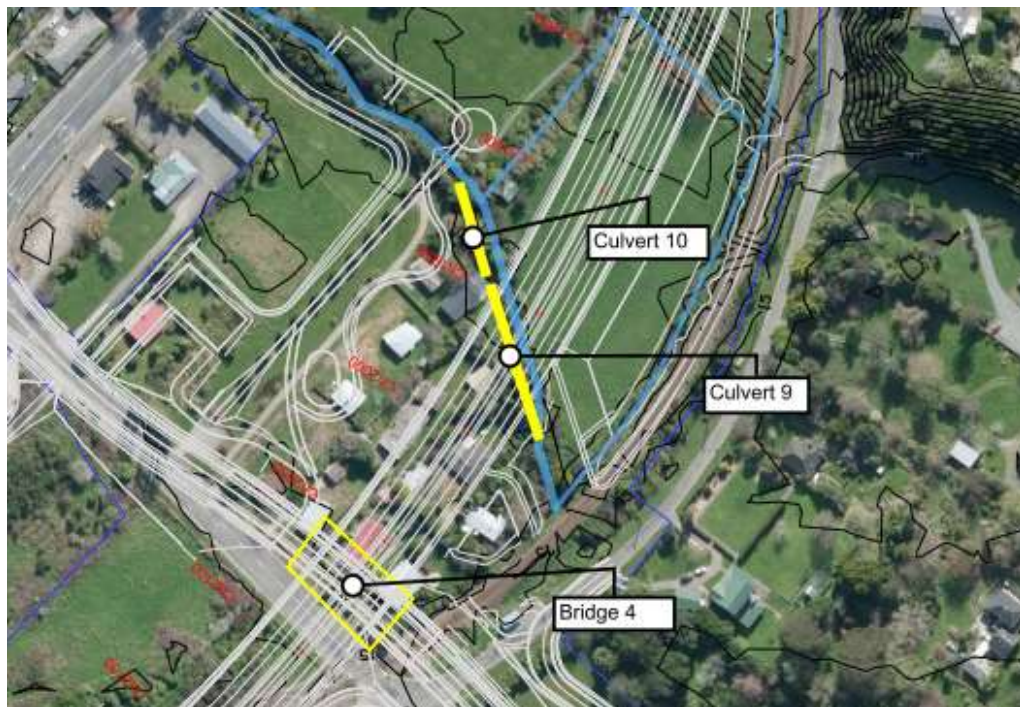

Figure 2: Location of Culvert's 9 and 10 north of Bridge 4

The general sequencing of culvert construction will be as follows:

4.2.1 Stage One: Temporary stream diversion

- If timing allows, early fish salvage and relocation methods will be carried out within the existing live watercourse using a combination of electric fishing and baited nets whilst fish exclusion nets are deployed to isolate the work site (refer to Section 5.3.2 for details). This will be the only stage where fish passage will temporarily be impeded. All other works will allow for fish passage during construction via use of a temporary stream diversion.
- The necessary erosion and sediment controls will be constructed in accordance with the attached drawings in Appendix C.
- The temporary stream diversion will be constructed off-line of the Mangapouri Stream in accordance with the temporary stormwater information outlined in Appendix D, leaving existing ground in place at the upstream and downstream end of the stream diversion as plugs.
- A temporary culvert crossing may be required within the temporary diversion (refer to section 4.4 below for details).
- Erosion and sediment controls are to be certified in accordance with Consent Condition E.6.
- Livening of the new channel and subsequent decommissioning of the existing channel can then proceed as follows:
 - Ecologist and Kaitiaki / Pūkenga to be present on site.
 - Removal of the downstream plug, allowing water to backflow up the new channel.
 - Removal of the upstream plug to fully liven the new channel.
 - Installation of an earth plug at the upstream end of the original channel.
 - Installation of an earth plug at the downstream end of the original channel.

- Ecologist and Kaitiaki / Pūkenga are to carry out fish salvage and relocation procedures within the original channel (now blocked).
- Following approval from the project ecologist and Pūkenga, water can be pumped from the channel in accordance with a permit to pump and the original channel can be excavated (note that an ecologist and Kaitiaki / Pūkenga must be present to carry out final visual checks of the muds for presence of fish).
- Construction of Culvert's 9 and 10 can then commence.

4.2.2 Stage Two: Culvert commissioning

- Upon completion of the new culverts and associated permanent diversions, erosion and sediment controls are to be installed and certified in accordance with Condition E.6.
- An ecologist and Kaitiaki / Pūkenga are to carry out a fish passage assessment prior to livening.
- The downstream plug can be removed, followed by the upstream plug to liven the new culvert.
- The inlet to the temporary diversion will be plugged using an earth bund, followed by the outlet to block the temporary diversion.
- The Ecologist and Kaitiaki / Pūkenga are to carry out fish salvage and relocation procedures within the redundant temporary diversion. If appropriate, early fish salvage and relocation will occur within the live watercourse using a combination of electric fishing and baited nets whilst fish exclusion nets are deployed to isolate the work site.
- Following approval by the project ecologist, water can be pumped from the temporary diversion in accordance with a permit to pump and the channel can be excavated (note that an ecologist and Kaitiaki / Pūkenga must be present to carry out final visual checks of the muds for present of fish).
- Following final approval by the project ecologist, the temporary diversion channel can be backfilled.

4.3 Temporary Stream Diversion Design

The temporary stream diversion is to be constructed in accordance with the stormwater requirements outlined in Appendix D. In general, the temporary stream diversion will be constructed as follows:

- Manning's equation has been used to estimate channel capacity, flow depths and velocities.
- Sized for up to 500 year ARI event (at max depth of 1.6m)
- 108m long
- Base width 0.5m
- Side slopes 2.5(H):1V
- Minimum depth 1.1m
- The channel will be lined such that flows do not result in erosion of the channel.

4.4 Temporary Culvert Crossing

It is likely that a temporary culvert crossing will be required within the temporary diversion. The culvert will be sized to convey the 50% AEP event in accordance with consent condition's WS.12-WS.14 as follows:

Temporary Culverts	
WS.12	All temporary culverts shall be designed to meet the following criteria unless otherwise agreed with the Manager: a) To pass a 50% AEP flood event without heading up (as assessed at the time of Commencement of Construction); b) Culverts to be installed 300mm below stream bed level in order to provide a continuous wetted perimeter to facilitate the passage of native fish species; and c) Minimum size of any temporary culvert shall be not less than 600mm in diameter.
WS.13	Unless otherwise agreed in writing with the Manager, upon removal of any temporary crossing, the consent holder shall reinstate the stream bed and margins to, as far as practicable, a natural state to closely match the upstream and downstream riparian and in-stream habitats and visual appearance.
WS.14	Unless otherwise agreed in writing with the Manager, all temporary stream crossings shall be removed within 2 years of their installation.

Final dimensions will be as-built and provided to GWRC in accordance with the certification process required by condition E.6. Requirements have been summarised in Appendix D.

4.5 Permanent Diversion Design

Two sections of permanent stream channel will be constructed immediately upstream of culvert 9 and immediately downstream of Culvert 10.

This section of the document has been updated since Revision C to now include a proposal for the final construction and livening of the Permanent Culvert's 9 and 10, including the two sections of permanent stream diversion which tie into the existing stream upstream and downstream. Culvert inlet / outlet riprap protection is required for a length of 14m at the outlet, and 30m at the inlet with both upstream and downstream sections transitioning into riparian planting at the tie-ins (34m upstream, and approximately 18m downstream). Upper RPC mix riparian planting has also been incorporated above the riprap at the upstream end. Refer to Appendix C 'Construction Drawings' which outline the confirmed planting plans in relation to riprap extents.

4.5.1 Channel Shape and Erosion Protection

The geometry of the diversion channels has generally been developed to mimic the existing stream in terms of conveyance capacity, longitudinal grade, cross-sectional shape, tightness (bend radius) and frequency of meanders.

Where necessary, channel bed and erosion protection measures have been designed. These include rock riprap armouring, designed using the USACE method EM 1601 (implementation referenced in NCHRRP Report 568), and for validation, compared against Austroads Waterway Design Rock Size Recommendation. General design details are attached as Appendix C 'Construction Drawings'.

4.5.2 Fish Passage

Fish passage is provided as follows:

- Providing cantered cross section inverts to provide flow depth for fish passage at low flows.
- Substrate will be matched to existing stream bed material. Rip rap will be covered with material that matches stream bed material where necessary to avoid interstitial flows and ensure flow depth for fish passage during low flows.

Appendix C contains relevant drawings relating to Culvert's 9 and 10.

Visual checks to assess fish passage will be carried out 1 year and 4 years following construction by a suitably qualified ecologist and engineer in accordance with Condition WS.9.

4.6 Bridge Construction

4.6.1 MSE Walls

The sequencing for the Reinforced Earth (RE) wall abutment construction shall be staged in order to accommodate the rail re-alignment works. The Western RE wall will be completed first, followed by the rail re-alignment and finally the Eastern RE wall.

As the RE wall progresses the earthworks tying into the wall will be carried out at the same time which will allow better access to the site.

The construction sequence for each RE wall is typically as follows:

- Construct RE base layer
- Excavate for footing beam
- Construct footing beam
- Construct RE Wall layers and any earthworks that ties into RE wall. All RE panels to be delivered progressively.
- Note that the RE wall will be constructed up to the underside of the abutment beam at which point the abutment beam will be constructed

4.6.2 Abutment Beams

The sequence for the abutment beams will follow directly on from the MSE wall.

- Erect abutment beam edge protection
- Prep and Pour blinding
- Fix reinforcing
- Form
- Pour
- Cure
- Strip
- Prep abutment beam for bearing and beam placement

4.6.3 Beams and Bearing Placement

Note that the sequencing of install for Bridge 4 will be governed by any track movements and rail authority approvals.

- Construct crane construction pads
- Mobilise the cranes to site into position as this will be a dual lift
- Deliver the first set of steel beams to site ready for fit out and lifting into position
- Dress the first beams with walkways and any other required items such as bridge services and fall protection. Once the beam has been fitted out, install in position
- Deliver and fit out remaining beams
- With beams installed, fit out any remaining bracing items
- Establish crane for installation of precast deck panels
- Deliver and install precast deck panels.

4.6.4 Deck Construction

- Seal deck using timber, ply and sealant for any voids between precast panels.
- Erect deck edge form and stop ends ready for reinforcing
- Fix reinforcing to height
- Establish screed rails
- Setup pump and associated secondary environmental and/or hazard controls where required
- Place and finish concrete
- Setup curing system which will consist of hessian and black plastic with a water feed on trickle. This will be in place for 7 days
- Remove curing system and dispose of accordingly
- Remove walkways off beams and install temporary edge protection ready for installation of the precast barriers

4.6.5 Continuation of MSE wall, settlement slab construction and abutment backfill

Note that across both abutments this operation needs to occur at the same time, this is to avoid creating uneven loads between the abutments.

- Form, reinforce and pour the insitu stitch between the abutment and MSE wall panels
- Complete the final layers of the RE wall
- Construct Settlement slab
- Setup curing system which will consist of hessian and black plastic with a water feed on trickle.
- Remove curing system and dispose of accordingly
- Backfill to required level

4.6.6 Barrier construction

Note that the sequence of install will be governed by any track movements and rail authority approvals

- Establish crane on abutment and atop MSE wall for installation of precast barriers.
- Deliver precast units to site and install.
- Install and grout rail atop of precast barrier.

4.7 Disposal Sites

Temporary stockpile locations have indicatively been marked on the drawing in Appendix C. Initially, soils will be stripped from the culvert footprints and the bridge footprint down to hard gravels and stockpiled on site (refer to contaminated land requirements in section 5.1). For the purposes of contaminated land management, “site” refers to the general HAIL area as outlined in Figure 3 below. Given the space restrictions at this site, this stockpile may not be greater than 50m distance away from the Mangapouri Stream. In accordance with D.C 25(g), appropriate treatment of stormwater runoff from this stockpile will be managed by use of silt fences to prevent sediment laden stormwater entering the Mangapouri Stream. This level of protection is considered appropriate to provide sufficient treatment.

4.8 Dewatering

Groundwater dewatering may be required during construction of Culvert’s 9 and 10 to maintain a dry working area. Groundwater will be pumped from a sump which typically will contain clean metal to ensure that it remains as clean as possible prior to discharge.

Water will be pumped to the Mangapouri Stream provided that it meets the following discharge standards:

- The discharge must not increase the downstream water quality within the receiving watercourse by >20% (compared to upstream levels).
- The discharge must not cause obvious visual discolouration of the downstream environment beyond ‘reasonable mixing’ (deemed as 30m from initial discharge point unless otherwise specified due to access restrictions).
- Permit to pump documentation must be available for inspection by GWRC upon request.

5 ENVIRONMENTAL REQUIREMENTS

5.1 Contaminated Land

As part of the AEE for the Project, a Phase One Contaminated Land Assessment was prepared by URS. This report identified land parcels within the Project boundary that had the potential to be contaminated and required further investigation. The location of works proposed in this SSEMP encroaches on one of these identified sites at 24-40 Rahui Road (referred to as the Rahui Road Northern Market Garden Site), which has been confirmed as being a site where activities listed on the Hazardous Activities and Industries List (HAIL) has occurred (namely persistent pesticide use and asbestos in soils). The definition of ‘Site’ in reference to contaminated land is the general HAIL location identified in figure 3 below.



Figure 3: Historic market garden outlined in red with the area of potential works outlined in yellow (the area outside of the yellow boundary will not be impacted by these works).

The level of disturbance of the pesticide and asbestos impacted soils has required a land use consent to be sought under Regulation 8 of the NESCS.

In regards to pesticides, the soils at the site do not pose a significant risk to human health or the environment and the proposed disturbance can be managed through the existing Bulk Earthworks Contaminated Land Management Plan (BECLMP), as well as the specific mitigation measures outlined below.

In regards to asbestos in the soils, an Asbestos Management Plan will be followed (attached as Appendix H) to effectively manage the handling of asbestos contaminated soils. All works will be carried out in accordance with the NESCS, the BRANZ Asbestos in Soil Guidelines, and the Health and Safety at Work (Asbestos) Regulations.

As a minimum the following specific requirements will be required for this site:

- The temporary stream diversion will be lined for construction purposes, and materials excavated to construct the diversion will be placed away from the stream and within appropriate sediment controls.
- Stripped topsoil and silts (down to gravels) will be temporarily stockpiled within the general HAIL area as indicated on Appendix C drawings.
- Soils at the site shall not be placed below water levels (i.e. wetlands, ponds, swales or permanent stream diversion).
- Soils containing asbestos will be managed in accordance with the Asbestos Management Plan (Attached as Appendix H).

- Additional requirements for management of soils within the temporary stockpile area will be actioned as follows:
 - Soils will be located within sediment controls to prevent sediment discharge off-site to land or water (refer to Figure 3 for the 'site' boundary in yellow). There is currently no clean water catchment running to the stockpile location. If this changes due to progression of works in the general area, clean stormwater will be diverted away from the stockpile location using clean water diversion bunds.
 - Following removal of the soils from the temporary stockpile location (to be undertaken at a later date in accordance with an approved global discharge consent yet to be approved by GWRC), further sampling will be undertaken of the underlying soils to demonstrate levels of contamination. This information will be used to inform the management approach for the next stage of works in this location.
 - Potential dust discharge from the temporary stockpile will be mitigated by the use of temporary stabilisation measures if required (i.e. polymers, temporary mulch, geotextile covers) to ensure that there is no discharge to air beyond the boundary of the site (refer to Figure 3 for the 'site' boundary in yellow).

5.2 Erosion and Sediment Control

- The total contributing catchment for this site is 6000m² on the northern side of the Mangapouri Stream, and 7000m² on the southern side of the stream.
- Based on the relatively small catchment sizes, as well as the contaminated land component to this site, silt fences are the preferred form of sediment control.
- Silt fences will be installed such that watercourses are protected throughout each stage of works.
- Sediment controls are not proposed along the southern extent of the site as the existing ground levels are higher along Rahui Road. As the abutments are built up for Bridge 4, this will be re-assessed and additional silt fencing installed if required.
- Location of all sediment controls are outlined on Appendix C 'Works methodology / layout' drawings.
- Any areas of the site that are not contained within sediment controls (i.e on the banks of the stream) will be removed immediately and / or stabilised using a combination of mulch and geotextile fabric.
- During livening of the temporary diversion and then the permanent channel, some final tie-in works will need to be carried out within the wetted channel. Works duration of this stage will be kept to a minimum with the placement of excavated material and works within the wetted channel reduced as far as practicable. Excavators will work from the upper banks with only the excavator bucket impacting the stream during the final tie-in works.

5.2.1 Installation and Decommissioning

Erosion and sediment control measures will be installed prior to all construction activities. Upon completion of the installation of all approved structural ESCs as-built certification plans will be provided to Council in writing prior to the activity commencing. The Project will submit certification

documentation 2 Working Days prior to the commencement of construction in that area of work as per condition E.6 and will retain the as-built record on site.

5.3 Ecological Requirements

Project ecological requirements are set out in the Ecological Management Plan (EMP) which outlines a number of locations that have specific requirements in regards to terrestrial and aquatic species that need to be considered prior to and during works. These have been further refined following input from the project ecologists to ensure that potential effects are minimised as far as practicable.

5.3.1 Terrestrial Ecology

There are no specific terrestrial requirements outlined in the EMP relevant to this area.

5.3.2 Aquatic Ecology

5.3.2.1 Fish salvage and relocation methods

Fish salvage and relocation procedures will be required within the Mangapouri Stream and the unnamed tributary due to be decommissioned. All fish salvage and relocation procedures will take place under the guidance of Ngā Hapu o Ōtāki and the project Ecologists.

The primary methods for capturing fish will be netting with baited nets set overnight, and electric fishing if appropriate. Fish salvage and relocation will typically take place as follows:

- A stop net will be deployed across the channel at the upstream and downstream ends of the works area at the commencement of the fish rescue operation to prevent fish from re-colonising the works areas. Alternatively, this first step will be removed and the channel blocked with earth plugs upstream and downstream.
- Fyke nets and gee minnow traps will be placed throughout the isolated section of water course. Nets will be left over night and cleared the next morning. If high numbers of fish are encountered following the second night of trapping further trapping may be required. Subsequent nights netting will be undertaken until the catch rate is below 50% of the previous pass or less than 10 individual fish captured (or as otherwise agreed with Ngā Hapu o Ōtāki).
- If appropriate, the length of stream will be electric fished by qualified technicians with repeat passes undertaken until the catch rate is below 50% of the previous pass or less than 10 individual fish captured.
- A freshwater ecologist and kaitiaki will be present on site at the time of dewatering the stream to ensure that any remaining fish are captured and relocated.
- All indigenous fish recovered will be transported and released to an appropriate relocation site (with input from Nga Hapu o Ōtāki regarding preferable locations).
- Appropriate handling methods will be used to minimise stress to the fish. Fish will be held in covered bins that will be regularly refreshed with stream water and transferred and released typically within 1 hour of being caught. Bubblers will be used if necessary to prevent asphyxiation.

- Exotic species captured through fish rescue exercises will not be transferred. Any exotic fish species captured will be euthanized humanely and disposed of appropriately.

Records of all fish relocated will be kept and provided in the written statement along with details on monitoring methodology, release location and monitoring dates.

5.3.2.2 Fish Migration

Consideration has been given to fish migration patterns specific to the Mangapouri Stream. In accordance with the project Ecological Management Plan (EMP), required fish migration management for in-stream works is as follows:

- Avoid peak upstream migration period for eels (December to March) where possible
- Minimise works period and undertake fish rescue

Refer to Appendix G which provides an abstract from the EMP identifying stream habitat and fish migration management.

5.4 Water Quality Monitoring

During livening of the temporary diversion, and then again during living of the permanent culverts and associated permanent stream diversion, turbidity monitoring will be undertaken upstream and downstream of the work site. In accordance with the EMP, if the turbidity level downstream of the works has not returned to levels within 10% of upstream levels within 48 hours of livening then GWRC will be notified and an investigation will be carried out to address the source of sediment release. All practicable measures will be taken to reduce the turbidity downstream at all times.

The following method will be applied for the livening of temporary diversion:

- Roaming turbidity loggers will be installed upstream and approximately 30m downstream of the diversion / Culvert 10 at least 24 hours prior to livening.
- The loggers will record continuously throughout the livening process to record to the peak discharge and the duration of increased turbidity.
- The loggers will continue to record turbidity until it can be demonstrated that downstream levels are within 10% of upstream levels.
- If downstream levels are elevated above 10% after 48 hours from livening then GWRC will be notified and an investigation will be carried out to address the source of sediment release.
- Monitoring results will be sent to GWRC within 10 working days of livening the diversion / culvert.

5.5 Cultural Monitoring

Pre-works baseline monitoring is to be undertaken by Ngā Hapu o Ōtaki in accordance with the Cultural Monitoring Plan (CMP) within the Mangapouri Stream

A Kaiarahi (iwi guide / leader) is the key point of contact and coordination for Ngā Hapū o Ōtaki. The Kaiarahi will be involved in the design process, construction supervision and environmental monitoring. The Kaiarahi will be supported by Pūkenga (specialists / experts) and Kaitiaki (guardians) who provide support in supervision, monitoring activities and provision of specialist advice in regards to cultural monitoring. Ngā Hapū o Ōtaki will be informed of all works on site and invited to be present for all works with particular emphasis placed on initial topsoil stripping and streamworks.

Contact must also be maintained with Muaupoko Tribal Authority (MTA) in accordance with MTA agreement and confirmed accidental discovery protocols.

5.6 Archaeology

All works under this SSEMP will be carried out in accordance with the approved archaeological authority and the Archaeological Site Management Plan. The Archaeological Site Management Plan outlines high, medium, and low probability archaeological areas across the project footprint.

This area is not identified as moderate or high probability. The area immediately to the north of this site titled 'Pare-o-matangi Block' in the Archaeological Management Plan is considered to be high probability of archaeological discovery. In the event that this area needs to be disturbed, then the Project Archaeologist and kaitiaki will need to be present on site to monitor the area. The on call protocols will be adhered to in all areas.

Refer to Appendix C 'Archaeological Map' for the location referred to as 'high probability', immediately north of the site.

5.7 Noise and Vibration

The Construction Noise and Vibration Management Plan (CNVMP) identifies the noise and vibration performance standards that must, where practicable, be complied with. It also sets out best practicable options for noise and vibration management for the Project, including mitigation measures, monitoring requirements, and communication and complaint procedures. All works under this SSEMP will be carried out in general accordance with the CNVMP.

Sensitive areas in regards to potential noise and vibration effects as a result of works have been identified in Appendix C. Individual dwellings located within these sensitive areas have also been listed below.

In accordance with the CNVMP, works carried out under this SSEMP will generally be restricted to take place between the hours of:

- 0630 and 2000hrs on weekdays; and
- 0730 and 1800hrs on Saturdays.

As far as practicable, works will be scheduled to avoid noisy activities in areas identified as sensitive receivers on the attached drawings between 0630 – 0730hrs in the morning, and between 1800 – 2000hrs in the evening to align with noise level criteria outlined in the CNVMP.

It is not anticipated that works will be required to take place outside of normal working hours for works outlined in this SSEMP. In the event that this changes, the procedures outlined in the CNVMP will be followed. Any works outside of the hours of 7am to 7pm require written approval from the Project Engineer.

The primary mitigation measure in regards to reducing the impacts from construction noise and vibration will be ongoing effective community consultation, particularly when transitioning from one works phase to another.

Noise and vibration monitoring will take place throughout the works to assess the impacts on adjacent properties at various locations. In the event that noise or vibration criteria is exceeded, mitigation options will be reassessed in an effort to comply with the construction limits, and a site specific noise 'schedule' will be submitted to Kapiti Coast District Council in accordance with the CNVMP.

Dwellings located within the sensitive noise and vibration areas are as follows:

- 47 Rahui Road
- Rahui Milk Station
- 294 SH1
- 290 SH1
- 62 Rahui Road
- 58 Rahui Road
- 56B Rahui Road
- 56A Rahui Road
- 52 Rahui Road
- Otaki Motel

Dwellings within the sensitive vibration areas only are as follows:

- 64 Rahui Road
- 60 Rahui Road
- 26 County Road
- 22 County Road
- 12 County Road
- 260 SH1
- BP Service Station
- 17 Hariata Street
- 15 Hariata Street
- 9 Hariata Street
- 5 Hariata Street
- 288 SH1
- 282 Mill Road
- 280 Mill Road
- 284 SH1

5.7.1 Pre-condition building surveys

Section 7 of the CNVMP outlines activities that are expected to generate vibration that will potentially cause medium and high level vibration and therefore must be assessed to determine whether a pre-condition building survey is required.

Pre-construction and post-construction building condition surveys will be carried out at the following properties prior to and following works:

- Rahui Milk Station
- Otaki Motel

5.8 Air Quality

There is potential for works to generate dust discharge if the site is not managed effectively. The Construction Air Quality Management Plan (CAQMP) outlines methods to be used to prevent dust and odour nuisance during construction from the site. All works under this SSEMP will be carried out in general accordance with the CAQMP.

To ensure that dust does not become an issue across the boundary of the site, the following measures will be implemented as a minimum:

- Use of water carts as required, particularly around public interface points such as site entry/exits to local roads
- Imposing a speed limit if required
- Use of stabilising agents such as polymers if required
- Assessing wind speed and direction on a daily basis

Certain properties fall within the 'high risk air quality' zone as identified in Appendix C 'Environmental Constraints' Drawings. Provided that the site is managed effectively, it is not anticipated that these works will cause an adverse impact in these locations.

6 TRAFFIC

Existing site access points will be utilised for these works from Rahui Road. A Site Specific Traffic Management Plan is included as Appendix F. Traffic management will adapt as works progress through the different stages.

Access to the Pare-o-matangi Reserve will remain open to the public and KCDC during the works. If at any time during the works the Reserve access is restricted then this will first be communicated to the following groups:

- KCDC Parks and Recreation
- 'Keep Ōtaki Beautiful' Group
- General Community (i.e. construction updates)

APPENDIX A – SSEMP AUTHORS

Name	Role	Company	Input
Alice Naylor	Environmental Manager	Higgins	All
Richard Rakovics	Project Civils Manager	Fletcher Construction	General sequencing and works methodology
Macu Waga	Site Engineer	Fletcher Construction	General sequencing and works methodology
Hamish Smith	Design Engineer	Tonkin & Taylor	Temporary stormwater design
Dean Miller	Lead Ecologist	Tonkin & Taylor	Ecological input

APPENDIX B – CONSULTATION RECORD

Group	Date
Community Liaison Group	Distributed to CLG Group for comment – no comments received.
Ngā Hapu o Ōtaki	Distributed for comment / feedback on cultural requirements – meeting held to discuss SSEMP 03/07/18 with no changes required.

Outstanding Queries

The following outlines any queries (relevant to works covered under this SSEMP) that have not been resolved through the SSEMP preparation process, but will instead be closed out via alternative project stakeholder and communication channels:

NIL

APPENDIX C – DRAWINGS

Works Methodology / Layout Plan

Stage 1 - Temporary stream diversion

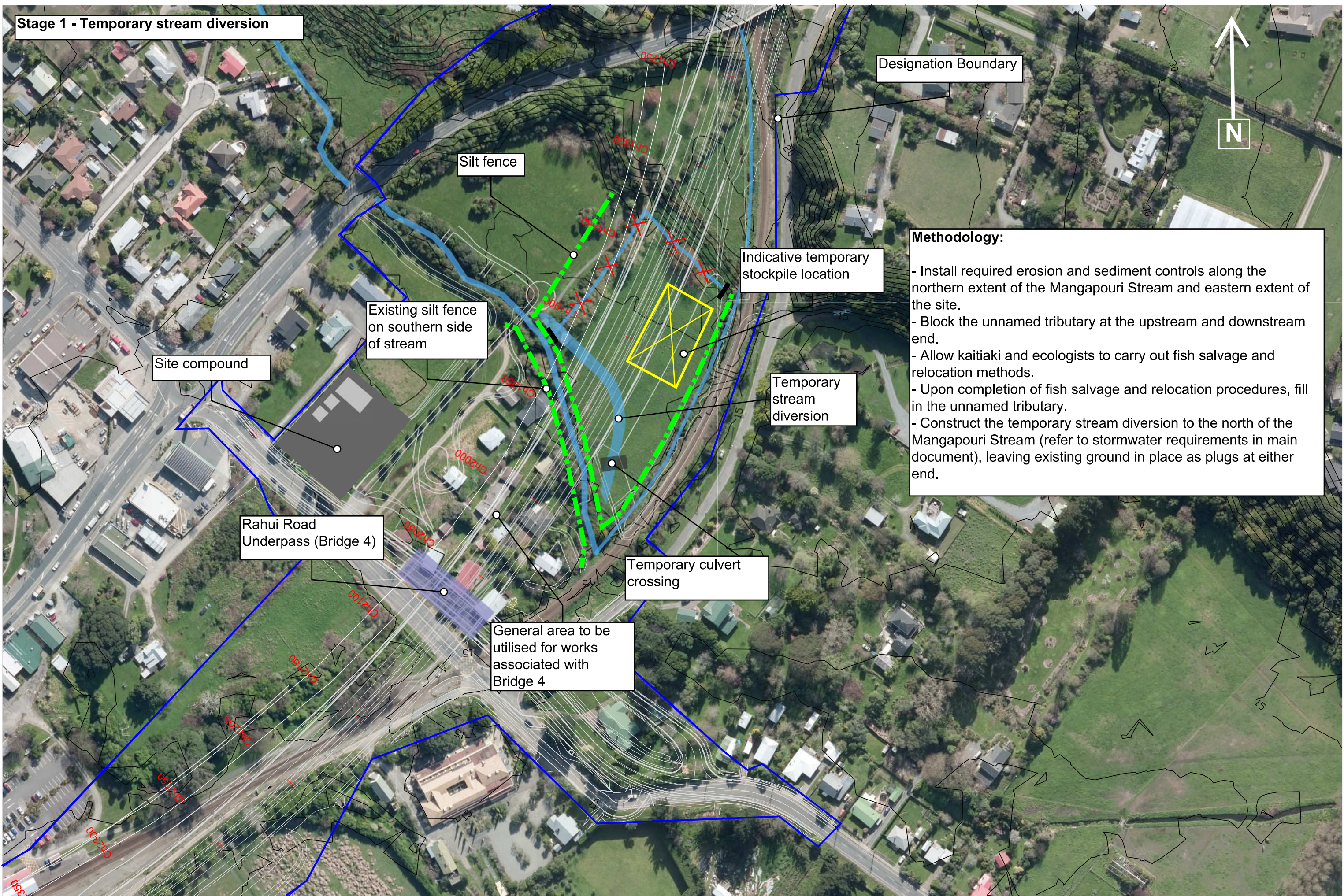

Methodology:

- Install required erosion and sediment controls along the northern extent of the Mangapouri Stream and eastern extent of the site.
- Block the unnamed tributary at the upstream and downstream end.
- Allow kaitiaki and ecologists to carry out fish salvage and relocation methods.
- Upon completion of fish salvage and relocation procedures, fill in the unnamed tributary.
- Construct the temporary stream diversion to the north of the Mangapouri Stream (refer to stormwater requirements in main document), leaving existing ground in place as plugs at either end.

Stage 2 - Culvert Construction

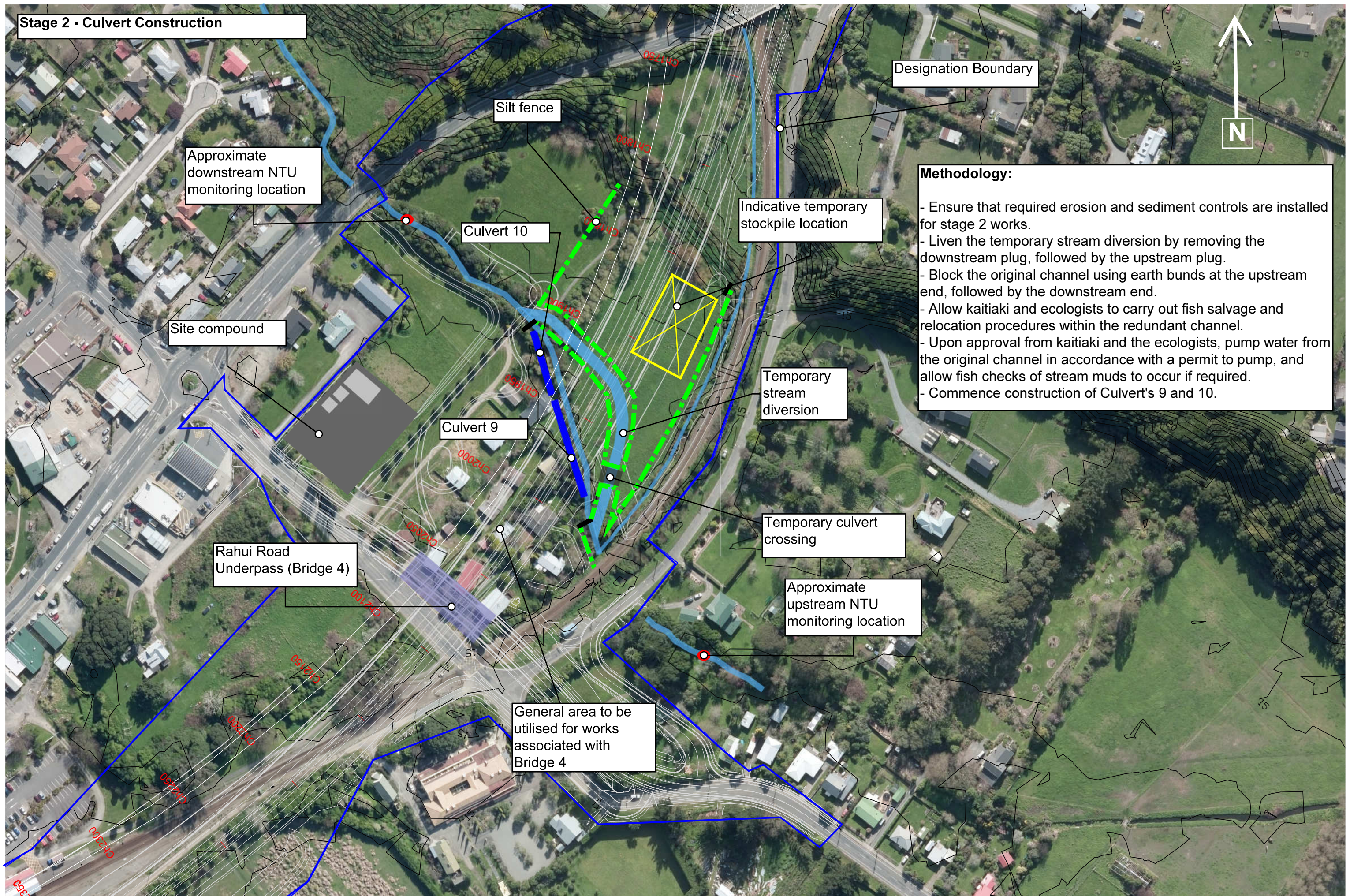

Methodology:

- Ensure that required erosion and sediment controls are installed for stage 2 works.
- Given the temporary stream diversion by removing the downstream plug, followed by the upstream plug.
- Block the original channel using earth bunds at the upstream end, followed by the downstream end.
- Allow kaitiaki and ecologists to carry out fish salvage and relocation procedures within the redundant channel.
- Upon approval from kaitiaki and the ecologists, pump water from the original channel in accordance with a permit to pump, and allow fish checks of stream muds to occur if required.
- Commence construction of Culvert's 9 and 10.

Stage 3 - Livening of Culvert's 9&10 and Bridge 4 Construction

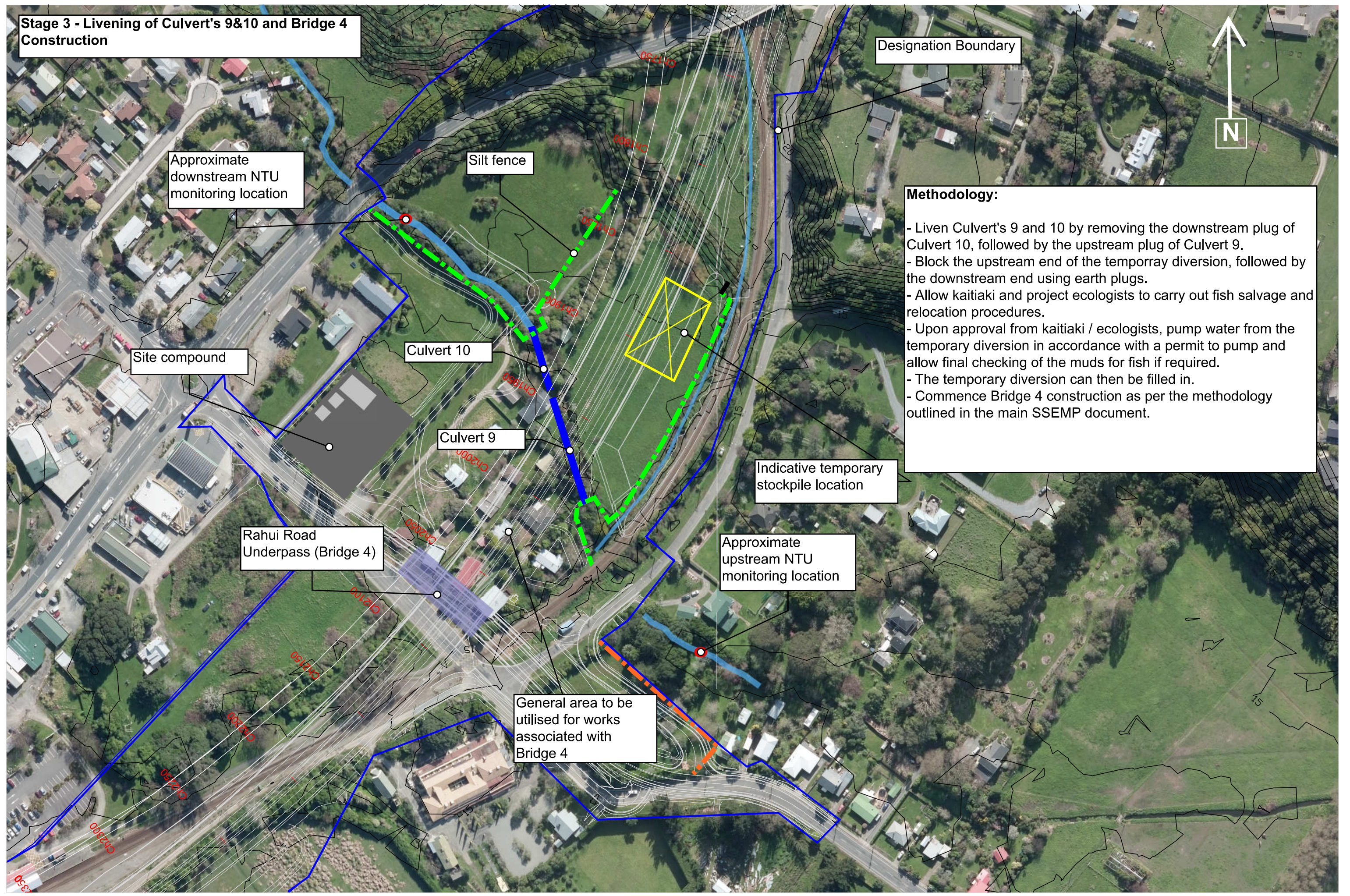

Methodology:

- Liven Culvert's 9 and 10 by removing the downstream plug of Culvert 10, followed by the upstream plug of Culvert 9.
- Block the upstream end of the temporary diversion, followed by the downstream end using earth plugs.
- Allow kaitiaki and project ecologists to carry out fish salvage and relocation procedures.
- Upon approval from kaitiaki / ecologists, pump water from the temporary diversion in accordance with a permit to pump and allow final checking of the muds for fish if required.
- The temporary diversion can then be filled in.
- Commence Bridge 4 construction as per the methodology outlined in the main SEMP document.

Environmental Constraints Drawings

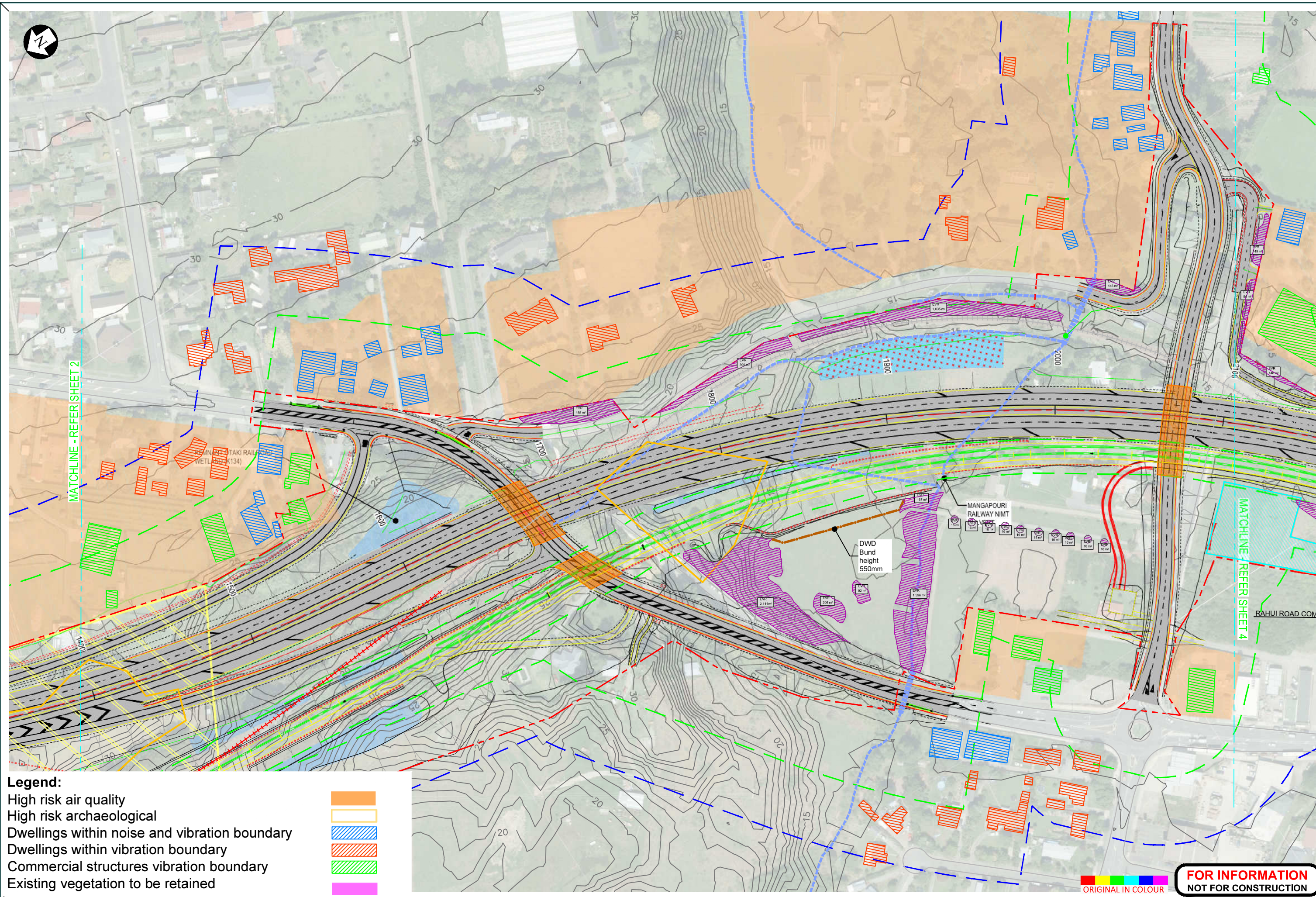

- Legend:**
- High risk air quality
 - High risk archaeological
 - Dwellings within noise and vibration boundary
 - Dwellings within vibration boundary
 - Commercial structures vibration boundary
 - Existing vegetation to be retained

ORIGINAL IN COLOUR

**FOR INFORMATION
NOT FOR CONSTRUCTION**

No.	Revision	By	Chk	Appd	Date
		WV	AK	GD	AN

Scale (A1) 1:1000	Design	AN	13.07.17	Approved For Construction
Scale (A3)	Drawn	AK	13.07.17	
	Dwg Verifier			
	Dwg Check			
	Date			

* Refer to Original Hardcopy for Signature

Peka Peka to Otaki Expressway

IFC_0301_SMALL_Cover_01130

Subject:	ECOLOGY
Title:	LAYOUT PLAN SHEET 3 OF 18

Discipline:	CIVIL
Drawing No.	PP20-DR-CE-0803
Rev.	B

Document No. \\MPPSP-FCC-INTERNAL\DA\WWW\ROOT\2020\2020\SECTOR GENERAL\PRECAST WORKING SHOP DRAWINGS\PP20\FOR ALICE\PP20-DR-CE-0801-0818_29-09-SET2.DWG

Construction Drawings

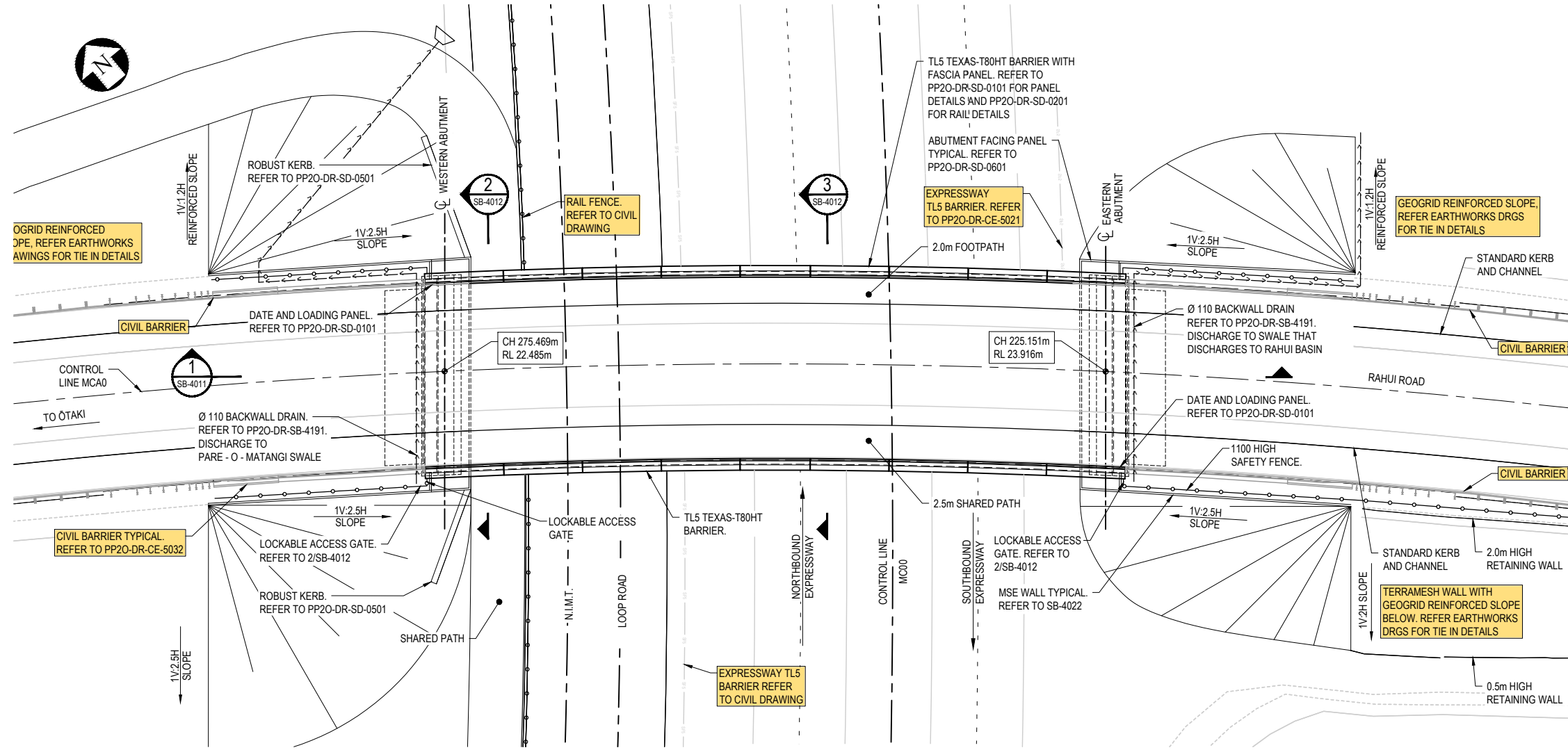

GENERAL ARRANGEMENT PLAN

SCALE 1:200 10. CONSTRUCTION SEQUENCE

NOTES:

1. REFERENCES
 - 1.1. REFER TO PP20-DR-SA-0001 TO PP20-DR-SA-0004 FOR GENERAL NOTES.
 - 1.2. REFER TO RELEVANT CIVIL DRAWINGS FOR CONTROL LINES, ROADING GEOMETRY, BARRIER EXTENTS, LANE WIDTHS ETC.
 - 1.3. REFER TO RELEVANT CIVIL DRAWINGS FOR LOCATION OF UTILITIES AND SERVICES.
 - 1.4. ALL LEVELS GIVEN ARE TO STRUCTURAL SURFACE UNO.
2. DESIGN STANDARDS
 - 2.1. NZTA BRIDGE MANUAL, THIRD EDITION (AMENDMENT 1, SEPT 2014), WITH PROJECT SPECIFIC AMENDMENTS.
 - 2.2. NZS 3101:2006 CONCRETE STRUCTURES STANDARD WITH PROJECT SPECIFIC AMENDMENTS.
 - 2.3. AS 5100.6:2004 BRIDGE DESIGN, PART 6: STEEL AND COMPOSITE CONSTRUCTION WITH PROJECT SPECIFIC AMENDMENTS.
 - 2.4. REFER TO DESIGN STATEMENT REPORT FOR FURTHER DETAILS.
3. DESIGN LOADING
 - 3.1. SUPERIMPOSED DEAD LOAD ALLOWANCE:
 - a) SURFACING = 2.0kPa (INCLUDING 0.5kPa FOR LEVELLING COURSE)
 - b) SERVICES - ALLOWANCES ARE MADE AS FOLLOWS:
 - i) 1 No Ø80mm DUCT FOR GAS ON SOUTH SIDE
 - ii) 2 No Ø100mm PVC DUCTS FOR ELECTRICITY AND ITS ON SOUTH SIDE
 - iii) 2 No 150mm DUCTS FOR FUTURE SERVICES (ONE ON EACH SIDE)
 - iv) ADDITIONAL UNIFORMLY DISTRIBUTED LOAD APPLIED OVER ENTIRE DECK AREA OF 25kPa
 - 3.1. TRAFFIC LOAD HN-HQ-72
 - 3.2. SEISMIC LOAD BASED ON:
 - a) SUBSOIL CLASS D
 - b) ULS AEP (1/2500)
 - c) ULS DESIGN PGA 0.567g
 - 3.1. TEMPERATURE AND DIFFERENTIAL TEMPERATURE AS PER NZTA BRIDGE MANUAL.
 - 3.2. CREEP AND SHRINKAGE BASED ON AS3600 AND NZTA BRIDGE MANUAL 3rd EDITION FOR RELATIVE HUMIDITY 80%.
 - 3.3. JACKING OF BRIDGE DECK FOR BEARING/ HORIZONTAL RESTRAINT REPLACEMENT. THE DESIGN INCLUDES THE FOLLOWING REQUIREMENTS:
 - a) TRAFFIC SHALL BE RESTRICTED TO 40km/h.
 - b) SEE ABUTMENT DRAWINGS FOR JACKING LOCATIONS AND LOADS.
 - c) JACKING LOADS ARE BASED ON HN LOADINGS
 - d) ALL JACKS AT EACH ABUTMENT SHALL BE HYDRAULICALLY LINKED AND HAVE A CENTRAL MECHANISM TO ENSURE THAT THE SAME VERTICAL DISPLACEMENTS OCCUR AT EACH JACKING POINT AT ALL TIMES DURING THE JACKING OPERATION.
 - e) BRIDGE BEARINGS ARE DESIGNED TO BE REPLACED USING LIFTS OFF NOT GREATER THAN 10mm.
 - f) STEEL PLATES SHALL BE PLACED BETWEEN CONCRETE BEARING SURFACE AND HYDRAULIC JACK.
 - g) MAXIMUM ALLOWABLE CONTACT PRESSURE BETWEEN CONCRETE SURFACE AND STEEL PLATE SHALL BE 25MPa.
 - j) HORIZONTAL RESTRAINTS AT ABUTMENTS SHALL BE MAINTAINED.

4. DRAWING LIST
 - 4.1. FOR THE LIST OF ALL DRAWINGS APPLICABLE TO THIS BRIDGE, REFER TO DRG SB-4000.
5. SPECIFICATIONS APPLICABLE TO THIS BRIDGE
 - 5.1. C0203 - BULK EARTHWORKS
 - 5.2. C0600 - REINFORCED CONCRETE SUPPLY
 - 5.3. C0601 - REINFORCED CONCRETE CONSTRUCTION
 - 5.4. C0614 - ANTI-GRAFFITI COATING
 - 5.5. C0700 - STRUCTURAL STEELWORK
6. CONSTRUCTION LOADS
 - 6.1. BRIDGE GIRDERS ARE DESIGNED FOR CONSTRUCTION LIVE LOAD OF 1.5kPa. TEMPORARY WORK SHALL BE ADEQUATE FOR 1/500 AEP (R = 1.0) SEISMIC AND WIND LOADING.
 - 6.2. LIFTING POSITIONS ARE NOMINATED ON THE GIRDER DRAWINGS.
7. STRUCTURAL ELEMENTS INCLUDED IN PACKAGE
 - 7.1. ABUTMENTS, APPROACH SLABS, STEEL GIRDERS, BEARINGS, TL5 TEXAS - T80HT TRAFFIC BARRIERS, BACKWALL, SAFETY FENCE AND BIRD PROOFING.
 - 7.2. TRAFFIC BARRIERS DETAILED IN THE STRUCTURAL DRAWINGS TERMINATE AT THE EXTENT OF THE BACK WALLS (BARRIERS BEYOND THAT ARE CONSIDERED TO BE STANDARD ROAD TRAFFIC BARRIERS. FOR THESE REFER TO THE RELEVANT CIVIL DRAWINGS).
8. COATING FOR EXPOSED CONCRETE SURFACES
 - 8.1. FOLLOWING TYPES OF COATING SHALL BE APPLIED TO EXPOSED CONCRETE SURFACES:
 - a) GRAFFITI SOLUTION COATING OR EQUIVALENT APPROVED BY THE PRINCIPAL AGENT.
 - 8.2. FOR THE APPLICATION OF SURFACE COATING REFER TO SPECIFICATION C0614.
 - 8.3. TABLE A SUMMARISES THE EXTENT OF COATINGS TO CONCRETE SURFACES.
9. COATINGS FOR EXPOSED STEEL SURFACES
 - 9.1. STRUCTURAL STEEL COMPONENTS SHALL BE COATED TO "C4" ATMOSPHERIC CORROSION CATEGORY USING THERMALLY SPRAYED ZINC (TSZ150S) OR HOT DIP GALVANISED (HDG900)
 - 9.2. ALL VISIBLE STEEL WORK SHALL HAVE A COLOURED FINISH COAT, APPROVED BY THE PRINCIPAL AGENT

TABLE A. CONCRETE SURFACE COATINGS

BRIDGE ELEMENTS	EXPOSED SURFACE	ANTI-GRAFFITI COATING
BRIDGE BARRIER	INSIDE FACES, (FACING RAHUI RD)	YES
	TOP SURFACE, OUTSIDE FACE OF FASCIA	YES
ABUTMENTS	FRONT FACES, (FACING EXPRESSWAY)	YES
	SIDES OF ABUTMENTS	YES
DECK SOFFIT	1.5m HORIZONTALLY FROM AN ACCESSIBLE SUBSTRUCTURE ELEMENT	YES

TABLE B. CONSTRUCTION SEQUENCE

SEQUENCE	ACTIVITY
1	INSTALL 2 SETTLEMENT PLATES IN THE SHOULDER OF EACH SIDE OF THE EMBANKMENT AT EXISTING GROUND LEVEL, 10m FROM EACH ABUTMENT (4 PLATES TOTAL). INSTALL 5 WEEKS PRIOR TO ANY EXCAVATION AND BEGIN MONITORING (TWICE WEEKLY).
2	EXCAVATE TO BASE OF PROPOSED HARDFILL RAFT AT WESTERN ABUTMENT (APPROXIMATELY 2m BELOW GROUND LEVEL) AND INSTALL WESTERN HARDFILL RAFT. DEWATER EXCAVATION IF REQUIRED. PROOF ROLL SUBGRADE (EXPECTED TO BE GRAVEL) AND SCALA TEST PRIOR TO CONSTRUCTING HARDFILL RAFT. SUBGRADE SHALL NOT SHOW SIGNS OF WEAVING, AND SHALL BE INSPECTED BY THE GEOTECHNICAL ENGINEER. ALL FILL MATERIALS SUBJECT TO ROUTINE EARTHWORKS TESTING.
3	CONSTRUCT WESTERN MSE WALLS AND APPROACH EMBANKMENTS. COMPLETE APPROX 5 MONTHS PRIOR TO CONSTRUCTING EASTERN MSE WALL. MONITOR SETTLEMENTS. GEOTECHNICAL ENGINEER TO CONFIRM REMAINING SETTLEMENT IS ACCEPTABLE PRIOR TO BRIDGE CONSTRUCTION.
4	INSTALL SETTLEMENT STATIONS IN EACH SHOULDER AND ROAD CENTERLINE AT TOP OF WESTERN EMBANKMENT, 10m FROM EACH ABUTMENT (3 STATIONS). INSTALL IMMEDIATELY FOLLOWING EMBANKMENT CONSTRUCTION AND BEGIN MONITORING (TWICE WEEKLY).
5	SWITCH RAIL FROM EXISTING TRACK ONTO NEW TRACK
6	EXCAVATE TO BASE OF PROPOSED HARDFILL RAFT AT EASTERN ABUTMENT (APPROXIMATELY 3m BELOW GROUND LEVEL) AND INSTALL EASTERN HARDFILL RAFT. DEWATERING, PROOF ROLLING AND TESTING AS PER WEST ABUTMENT.
7	CONSTRUCT EASTERN MSE WALLS AND APPROACH EMBANKMENTS.
8	INSTALL SETTLEMENT STATIONS IN EACH SHOULDER AND ROAD CENTERLINE AT TOP OF EASTERN EMBANKMENT, 10m FROM EACH ABUTMENT (3 STATIONS). INSTALL IMMEDIATELY FOLLOWING EMBANKMENT CONSTRUCTION AND BEGIN MONITORING (TWICE WEEKLY).
9	MONITOR SETTLEMENT OF BRIDGE ABUTMENT AND 'HOLD' CONSTRUCTION (IF NECESSARY). REQUIREMENT FOR 'HOLD' PRIOR TO CONSTRUCTION OF EAST ABUTMENT BANKSEAT SHALL BE CONFIRMED FOLLOWING REVIEW OF SETTLEMENT MONITORING RESULTS AT WEST ABUTMENT. REPORT TO BRIDGE DESIGNER IF THE RL'S AFTER SETTLEMENT ARE ±15mm DIFFERENT FROM THE FIGURE SHOWN IN DRAWING.

TABLE B. CONSTRUCTION SEQUENCE

SEQUENCE	ACTIVITY
10	CONSTRUCT ABUTMENT BANK SEAT. ENSURE RL'S FOR BEARINGS ARE WITHIN ACCEPTABLE TOLERANCE OF ±15mm.
11	INSTALL STEEL GIRDERS WITH BEARINGS.
12	CAST ABUTMENT BACKWALL.
13	SETTLEMENT PINS SHALL BE INSTALLED PRIOR TO PLACING BRIDGE DECK. INSTALL 3 AT EACH ABUTMENT (ONE IN BOTH SHOULDERS AND CENTRELINE, BOTH ENDS OF BRIDGE). BEGIN MONITORING IMMEDIATELY FOLLOWING BRIDGE CONSTRUCTION (TWICE WEEKLY).
14	COMPLETE BRIDGE DECK INCLUDING TEMPORARY SURFACE WATER CONTROL.
15	BACKFILL UP TO SETTLEMENT SLAB.
16	INSTALL SETTLEMENT SLABS.
17	COMPLETE BACKFILL ADJACENT TO ABUTMENT BACKWALLS.
18	COMPLETE SURROUNDING EARTHWORKS AND SURFACE WATER CONTROL.
19	PLACE BARRIER, POUR BARRIER STITCH AND INSTALL TOP RAILS.
20	MONITOR SETTLEMENT OF BRIDGE ABUTMENTS AND APPROACH EMBANKMENTS.
21	COMPLETE BRIDGE PAVEMENT, APPROACH EMBANKMENT PAVEMENT AND ANCILLARY ITEMS.
22	INSTALL UTILITIES TO THE BRIDGE AND RELOCATE TRAFFIC.
23	REFER SPECIFICATION FOR REDUCED SETTLEMENT MONITORING FREQUENCIES 3 MONTHS FOLLOWING BRIDGE CONSTRUCTION.

THE ABOVE CONSTRUCTION SEQUENCE SHOWS THE SEQUENCING AS ASSUMED FOR DESIGN PURPOSES. CONSTRUCTOR TO ADVISE DESIGNER IF ALTERNATIVE CONSTRUCTION SEQUENCE IS PROPOSED.

FOR CONSTRUCTION

No.	Revision	By	Chk	Appd	Date
1	FOR CONSTRUCTION	CRB	ARK	JK	22.11.17

Scale (A1) AS SHOWN	Scale (A3)	Design	Drawn	Checked	Approved For Construction	Date
		A.KIVELL	C.BURKE	G.BROWN	B.SYMMANS	23.02.17
				B.FLYNN		22.11.17
						22.11.17

* Refer to Original Hardcopy for Signature

Subject:	RAHUI ROAD UNDERPASS (BRIDGE 4)
Title:	GENERAL ARRANGEMENT PLAN

Discipline:	STRUCTURAL
Drawing No.:	PP20-DR-SB-4001
Rev.:	1

Document No. R13000 - DESIGN DEVELOPMENT GENERAL09 CAD/DRAWINGS/PP20-DR-SB-4001.DWG

- NOTES:**
1. REFER TO PP20-DR-SA-0001 TO PP20-DR-SA-0004 FOR GENERAL NOTES.
 2. REFER TO PP20-DR-SB-4001 FOR BRIDGE SPECIFIC NOTES.
 3. MSE WALLS ARE DESIGNED BY REINFORCED EARTH LTD (REL).
 MINIMUM REINFORCEMENT LENGTH = 7m.
 MINIMUM EMBEDMENT BELOW GROUND LEVEL = 0.5m.
 REFER TO DRAWINGS 6089C/C/01 TO 6089C/C/14 FOR MSE WALL INFORMATION.

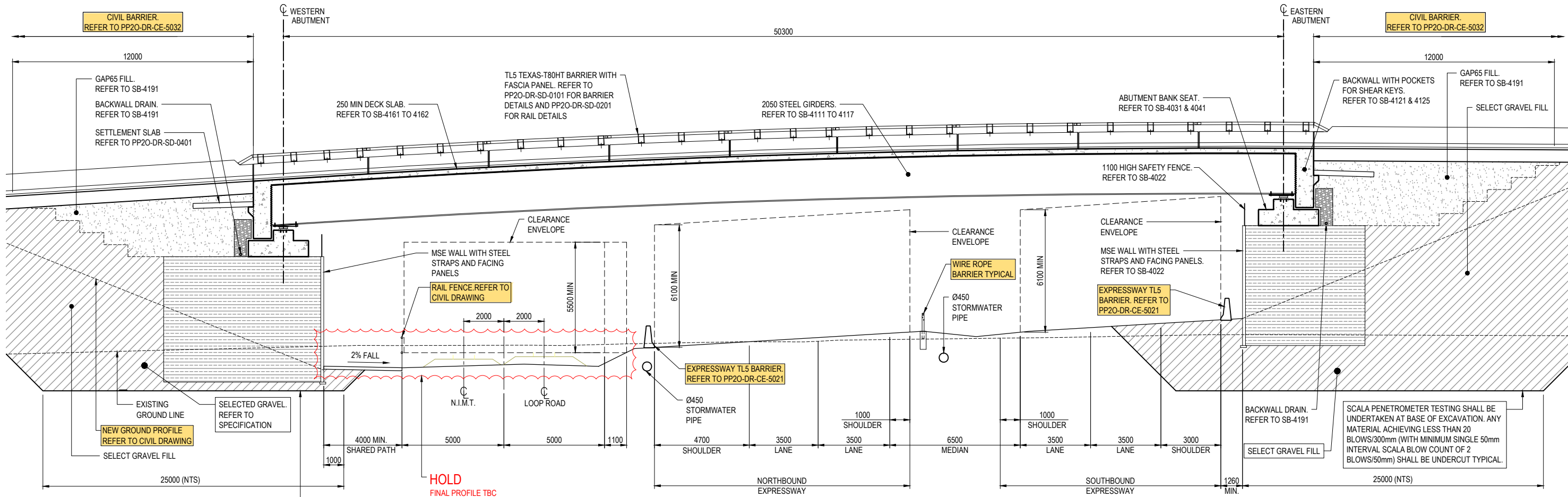

SCALA PENETROMETER TESTING SHALL BE UNDERTAKEN AT BASE OF EXCAVATION. ANY MATERIAL ACHIEVING LESS THAN 4 BLOWS/100mm SHALL BE UNDERCUT AND REPLACE WITH COMPACTED SELECT GRAVEL FILL.

SCALA PENETROMETER TESTING SHALL BE UNDERTAKEN AT BASE OF EXCAVATION. ANY MATERIAL ACHIEVING LESS THAN 20 BLOWS/300mm (WITH MINIMUM SINGLE 50mm INTERVAL SCALA BLOW COUNT OF 2 BLOWS/50mm) SHALL BE UNDERCUT TYPICAL.

HOLD
 FINAL PROFILE TBC
 BY KIWIRAIL

FOR CONSTRUCTION

No.	Revision	By	Chk	Appd	Date
1	FOR CONSTRUCTION	CRB	ARK	JK	22.11.17

Scale (A1) AS SHOWN	Design	Drawn	Drawn Date	Approved For Construction	Approved For Construction Date
Scale (A3)	A.KIVELL	C.BURKE	23.02.17	B.SYMMANS	23.11.17
		G.BROWN	09.02.17		
		B.FLYNN	22.11.17		

* Refer to Original Hardcopy for Signature

NZ TRANSPORT AGENCY **Peka Peka to Ōtaki Expressway** **Fletcher HIGGINS** **BECA** **Tonkin+Taylor**

Subject:	RAHUI ROAD UNDERPASS (BRIDGE 4)	Discipline:	STRUCTURAL
Title:	GENERAL ARRANGEMENT SECTIONS SHEET 1	Drawing No.:	PP20-DR-SB-4011
		Rev.:	1

- NOTES:**
1. REFER TO PP20-DR-SA-0001 TO PP20-DR-SA-0004 FOR GENERAL NOTES.
 2. REFER TO PP20-DR-SB-4001 FOR BRIDGE SPECIFIC NOTES.
 3. THE SERVICES SUPPORT SYSTEM SHALL BE A UNISTRUT PROPRIETARY SYSTEM DESIGNED BY THE SUPPLIER.
 4. THE SUPPLIER SHALL PROVIDE THE FIXING REQUIREMENTS FOR THE SERVICES SUPPORT SYSTEM TO CAST IN TO THE DECK SLAB.

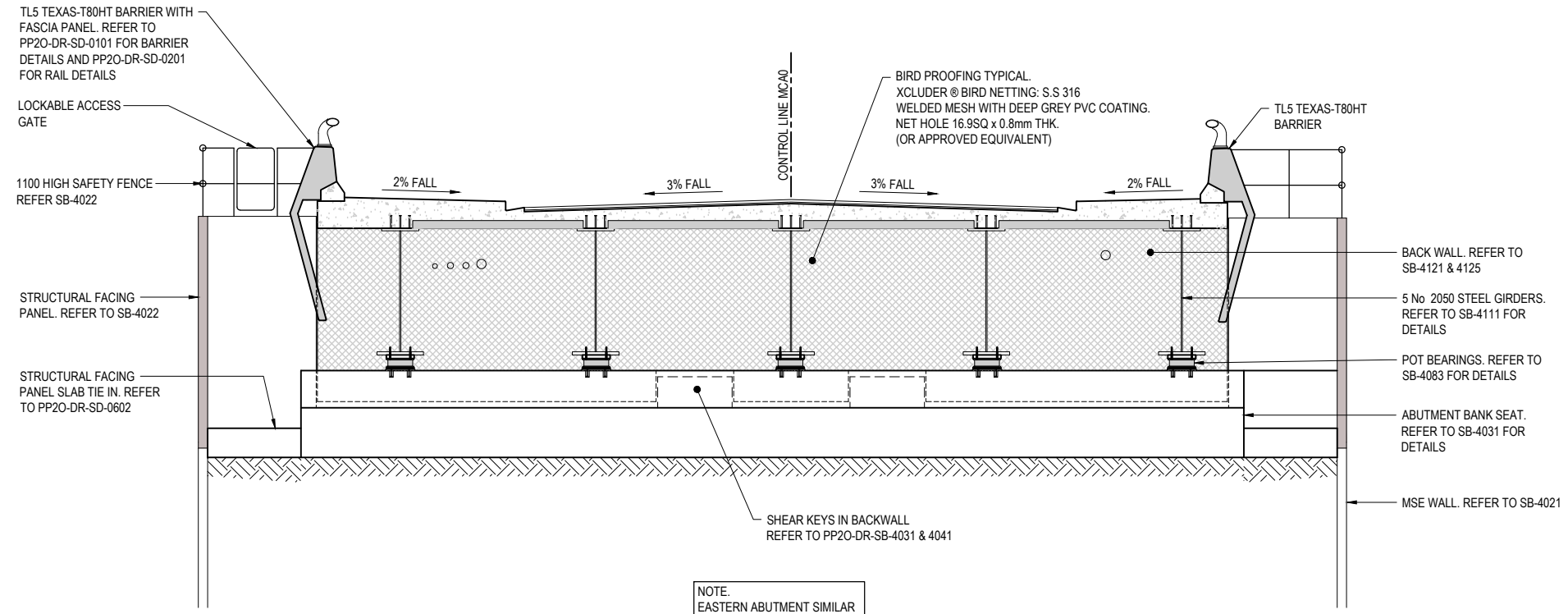

2 WESTERN ABUTMENT ELEVATION
SB-4001 SCALE 1:50

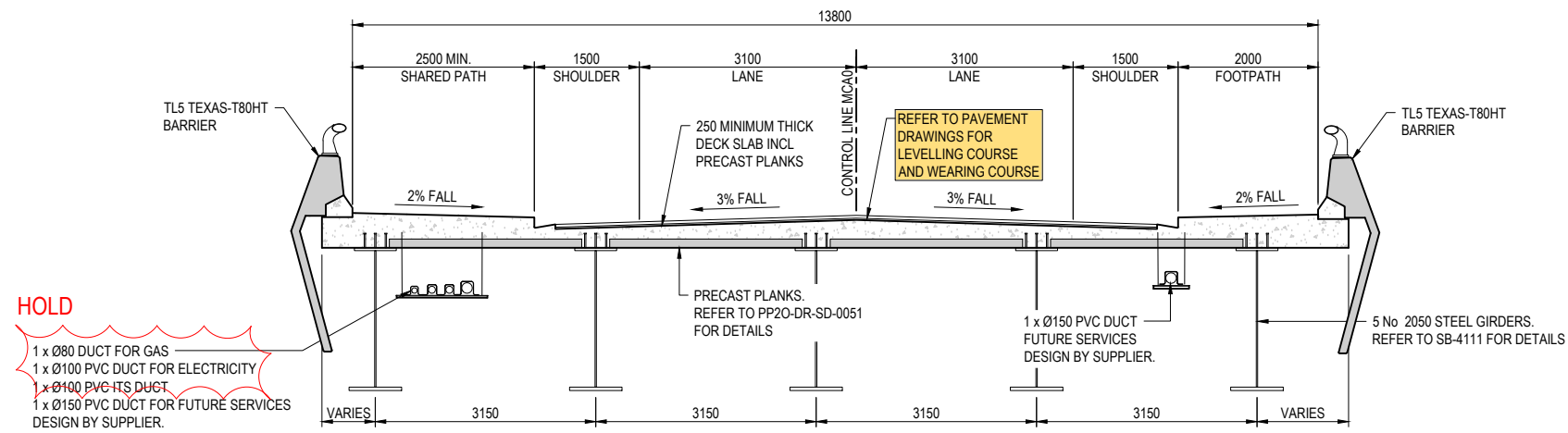

3 TYPICAL CROSS SECTION
SB-4001 SCALE 1:50

FOR CONSTRUCTION

No.	Revision	By	Chk	Appd	Date
1	FOR CONSTRUCTION	CRB	ARK	JK	22.11.17

Scale (A1)	Design	A.KIVELL	23.02.17	Approved For Construction
AS SHOWN	Drawn	C.BURKE	09.02.17	B.SYMMANS
Scale (A3)	Desg Verifier	G.BROWN	22.11.17	
	Desg Check	B.FLYNN	22.11.17	Date 23.11.17

* Refer to Original Hardcopy for Signature

NZ TRANSPORT AGENCY WAIKATO

Peka Peka to Ōtaki Expressway

Fletcher HIGGINS

BECA

Tonkin+Taylor

Subject:	RAHUI ROAD UNDERPASS (BRIDGE 4)	Discipline:	STRUCTURAL
Title:	GENERAL ARRANGEMENT SECTIONS SHEET 2	Drawing No.:	PP20-DR-SB-4012
		Rev.:	1

- NOTES:**
1. REFER TO PP20-DR-SA-0001 TO PP20-DR-SA-0004 FOR GENERAL NOTES.
 2. REFER TO PP20-DR-SB-4001 FOR BRIDGE SPECIFIC NOTES.
 3. ALL RL'S GIVEN ARE IN REFERENCE TO FINISHED GROUND LEVEL
 4. REFER TO CONSTRUCTION MANAGEMENT PLAN FOR DETAILS.

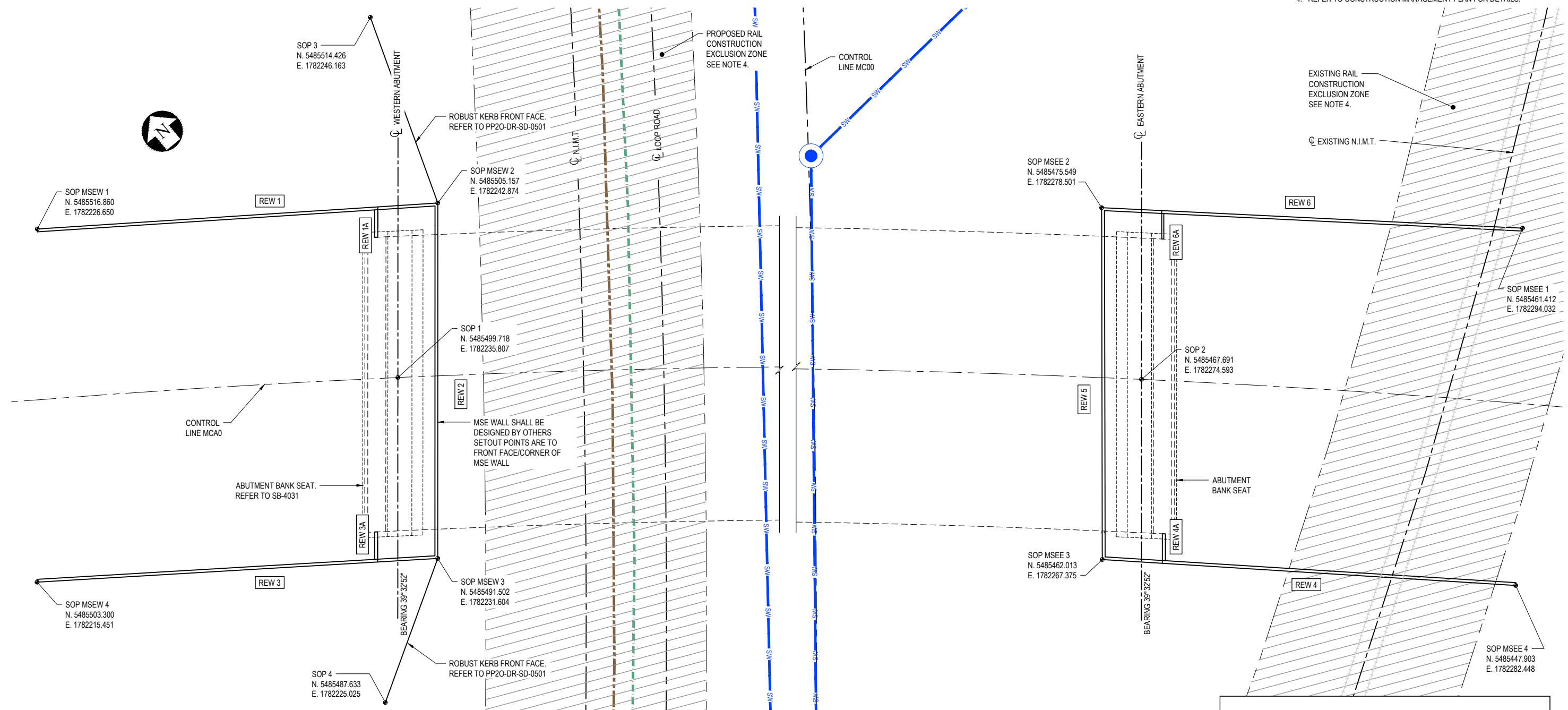

SUBSTRUCTURE SETOUT PLAN
SCALE 1:100

SERVICES LEGEND:

EXISTING		NEW	
— W —	PUBLIC WATER	— W —	PUBLIC WATER
— HW —	HAUTERE WATER	— HW —	HAUTERE WATER
— AW —	ARCUS WATER (PRIVATE IRRIGATION SUPPLY)	— AW —	ARCUS WATER (PRIVATE IRRIGATION SUPPLY)
— SW —	STORMWATER	— SW —	STORMWATER
— SS —	SANITARY SEWER	— SS —	SANITARY SEWER
— OH —	ELECTRA - OVERHEAD POWER CABLES	— OH —	ELECTRA - OVERHEAD POWER CABLES
— P —	ELECTRA - UNDERGROUND POWER CABLES	— P —	ELECTRA - UNDERGROUND POWER CABLES
— G —	GAS	— G —	GAS
— T —	CHORUS - TELECOMMUNICATIONS	— T —	CHORUS - TELECOMMUNICATIONS
— — —	KIWRIL FIBRE CABLE	— — —	KIWRIL FIBRE CABLE
— — —	KIWRIL SIGNALS CABLE	— — —	KIWRIL SIGNALS CABLE
+++++	RAILWAY	+++++	RAILWAY
---	TO BE REMOVED	---	TO BE REMOVED

FOR CONSTRUCTION

No.	Revision	By	Chk	Appd	Date
1	FOR CONSTRUCTION	CRB	ARK	JK	22.11.17

Scale (A1)	AS SHOWN	Design	A.KIVELL	23.02.17	Approved For Construction
Scale (A3)		Drawn	C.BURKE	09.02.17	B.SYMMANS
		Design Checker	G.BROWN	22.11.17	
		Design Check	B.FLYNN	22.11.17	Date 23.11.17

* Refer to Original Hardcopy for Signature

NZ TRANSPORT AGENCY | **Peka Peka to Ōtaki Expressway** | **Fletcher HIGGINS** | **BECA** | **Tonkin+Taylor**

Subject:	RAHUI ROAD UNDERPASS (BRIDGE 4)	Discipline:	STRUCTURAL
Title:	GENERAL ARRANGEMENT SUBSTRUCTURE SETOUT PLAN	Drawing No.:	PP20-DR-SB-4021
		Rev.:	1

- NOTES:**
1. REFER TO PP20-DR-SA-0001 TO PP20-DR-SA-0004 FOR GENERAL NOTES.
 2. REFER TO PP20-DR-SB-0001 FOR BRIDGE SPECIFIC NOTES.
 3. REFER TO PP20-DR-SD-0601 FOR STRUCTURAL FACING PANEL DETAILS.
 4. RL'S REFER TO FINISHED GROUND LEVEL.
 5. REW # = REFER TO REINFORCED EARTH WALL NUMBER. REFER TO RE WALL DRAWINGS FOR DETAILS.

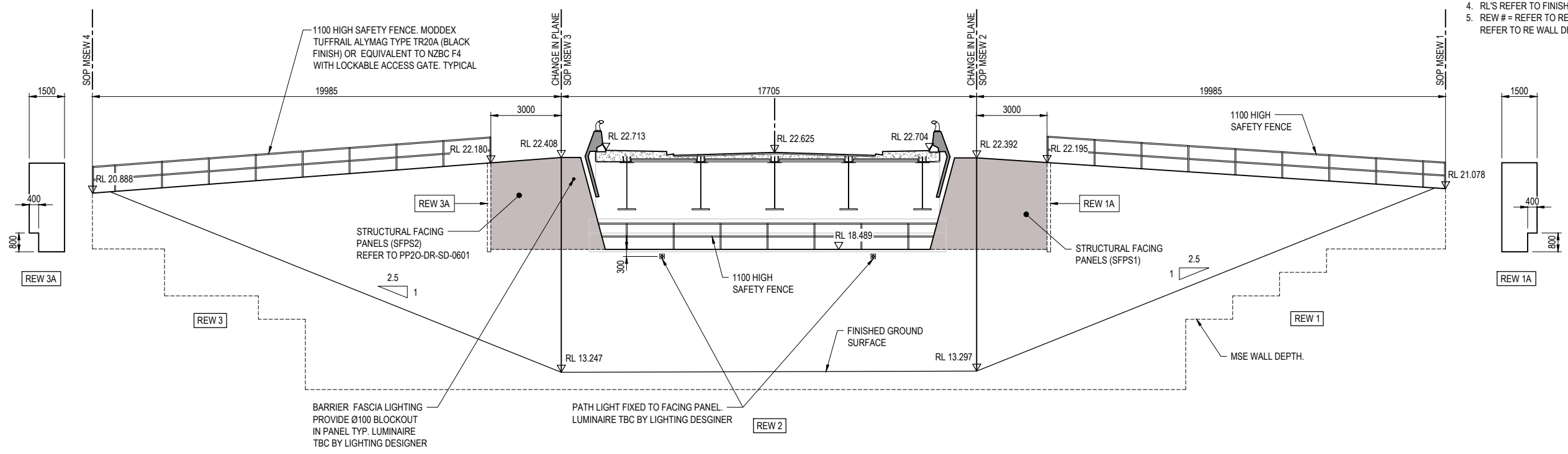

WESTERN ABUTMENT MSE WALL ELEVATION
SCALE 1:100

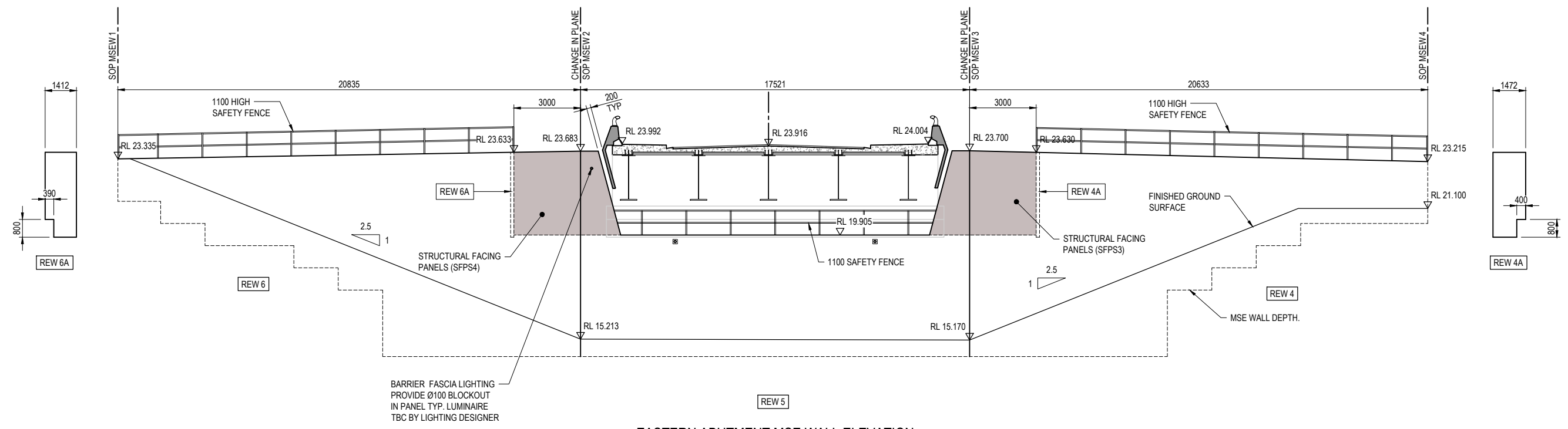

EASTERN ABUTMENT MSE WALL ELEVATION
SCALE 1:100

TABLE 1. STRUCTURAL FACING PANEL DIMENSIONS

PANEL	A (mm)	B (mm)	C (mm)	D (mm)	E (mm)	F (mm)	G (Degrees)
SFPS1	940	1990	3905	2820	3805	350	86°
SFPS2	825	1875	3920	2820	3790	350	93°
SFPS3	785	1800	3795	2820	3825	350	94°
SFPS4	795	1810	3780	2820	3830	350	87°

REFER NOTE 4.

FOR CONSTRUCTION

No.	Revision	By	Chk	Appd	Date
1	FOR CONSTRUCTION	CRB	ARK	JK	22.11.17

Scale (A1) AS SHOWN	Design	Drawn	Checked	Approved For Construction
Scale (A3)	A.KIVELL 23.02.17	C.BURKE 02.05.17	G.BROWN 22.11.17	B.SYMMANS 23.11.17

Subject:	RAHUI ROAD UNDERPASS (BRIDGE 4)	Discipline:	STRUCTURAL
Title:	SUBSTRUCTURE DETAILS	Drawing No.:	PP20-DR-SB-4022
		Rev.:	1

Document No. R13000 - DESIGN DEVELOPMENT GENERAL09 CAD/DRAWINGS/PP20-DR-SB-4022.DWG

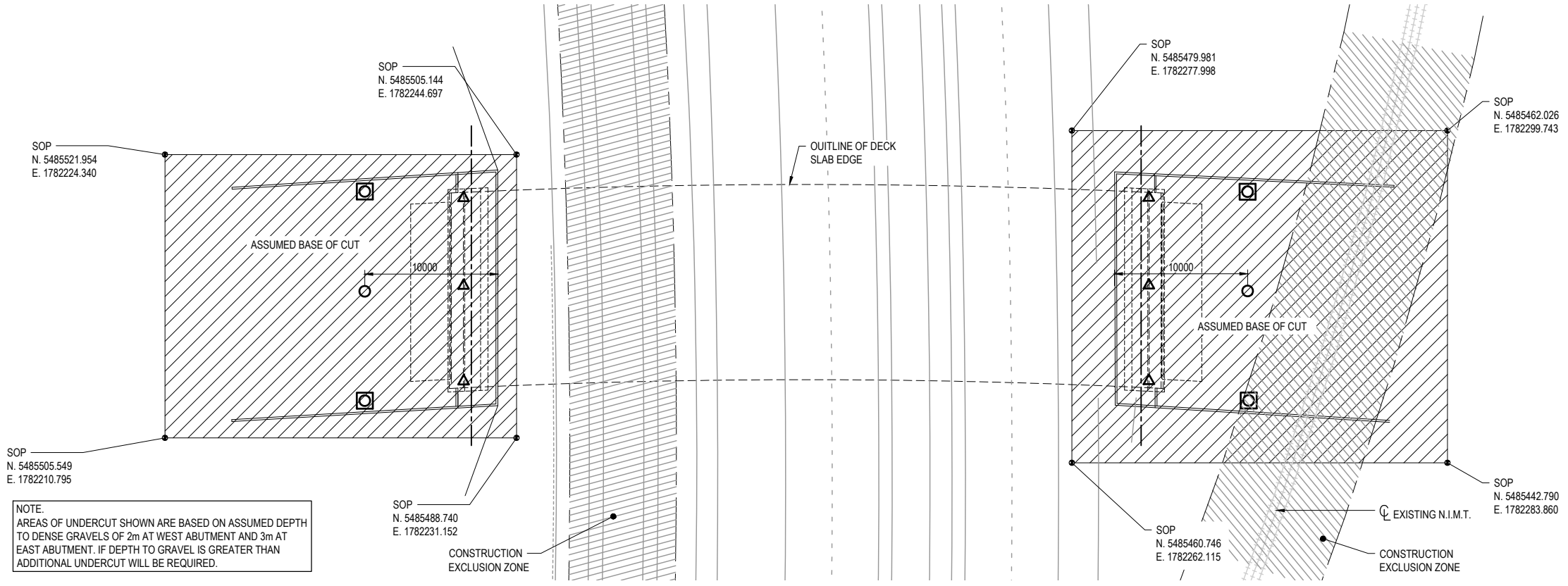

NOTE:
AREAS OF UNDERCUT SHOWN ARE BASED ON ASSUMED DEPTH TO DENSE GRAVELS OF 2m AT WEST ABUTMENT AND 3m AT EAST ABUTMENT. IF DEPTH TO GRAVEL IS GREATER THAN ADDITIONAL UNDERCUT WILL BE REQUIRED.

- NOTES:**
- REFER TO PP20-DR-SA-0001 TO PP20-DR-SA-0004 FOR GENERAL NOTES.
 - REFER TO PP20-DR-SB-4001 FOR BRIDGE SPECIFIC NOTES.
 - ABUTMENT BACKFILLING AND COMPACTION SHALL BE CARRIED OUT AFTER BACKWALL HAS REACHED ITS 28 DAY STRENGTH.
 - BACKFILL SHALL BE INSTALLED WITH A MAXIMUM DIFFERENTIAL BETWEEN ABUTMENTS OF 0.5m
 - ALL CONSTRUCTION PLANT AND OTHER VEHICLES WITH A MASS EQUAL TO OR GREATER THAN 1500kg SHALL BE KEPT A MINIMUM OF 3m AWAY FROM THE BACK OF THE WALLS.
 - THE PLANT USED FOR COMPACTING FILL MATERIAL SHALL BE RESTRICTED TO:
 - VIBRATING ROLLERS WITH A MASS PER METRE WIDTH OF ROLLER NOT EXCEEDING 1300kg AND A TOTAL MASS THAT SHALL NOT EXCEED 1500kg.
 - VIBRATING PLATE COMPACTORS WITH A MASS THAT SHALL NOT EXCEED 100kg.
 - VIBRO TAMPERS WITH A MASS THAT SHALL NOT EXCEED 75kg.
 - BACKFILL MATERIAL BEHIND ABUTMENT:
 - SHALL BE COMPACTED GAP65 FILL IN SPECIFICATION C0203.
 - SHALL EXTEND A MINIMUM OF 6m BEHIND THE BANKSEAT, MEASURED AT THE BASE OF THE BANKSEAT.
 - APPROACH EMBANKMENT FILL SHALL BE SELECT GRAVEL FILL. REFER TO EARTHWORKS PACKAGE FOR OTHER EMBANKMENT REQUIREMENTS AND GEOMETRY. REFER BULK EARTHWORKS SPECIFICATION C0203 FOR COMPACTION REQUIREMENTS.

SETTLEMENT MONITORING LEGEND:

SETTLEMENT PINS (ON BRIDGE)	▲
SETTLEMENT PLATES (AT BASE UNDERCUT) WITH PLASTIC SLEEVE THROUGH EMBANKMENT	□
SETTLEMENT STATION (AT TOP OF EMBANKMENT) REFER PP20-DR-GE-0131 AND 0132 FOR TYPICAL DETAILS	○

EARTHWORKS PLAN
SCALE 1:200

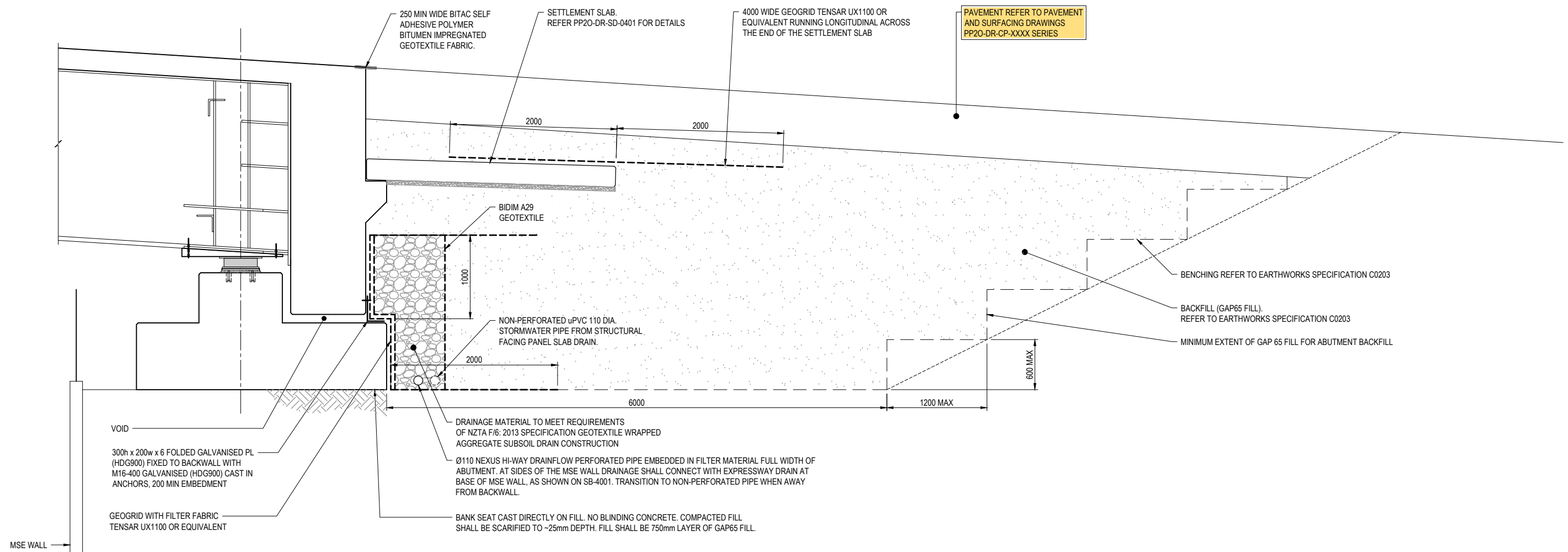

TYPICAL SECTION OF ABUTMENT BACKFILL
SCALE 1:25

FOR CONSTRUCTION

No.	Revision	By	Chk	Appd	Date
1	FOR CONSTRUCTION	CRB	ARK	JK	22.11.17

Scale (A1)	Design	A.KIVELL	20.06.17	Approved For Construction
Scale (A3)	Drawn	C.BURKE	22.06.17	B.SYMMANS
	Design Checker	G.BROWN	22.11.17	
	Design Check	B.FLYNN	22.11.17	Date 23.11.17

* Refer to Original Hardcopy for Signature

NZ TRANSPORT AGENCY | **Peka Peka to Ōtaki Expressway** | **Fletcher HIGGINS** | **BECA** | **Tonkin+Taylor**

Subject:	RAHUI ROAD UNDERPASS (BRIDGE 4)	Discipline:	STRUCTURAL
Title:	EARTHWORKS, BACKFILLING, AND DRAINAGE	Drawing No.:	PP20-DR-SB-4191
		Rev.:	1

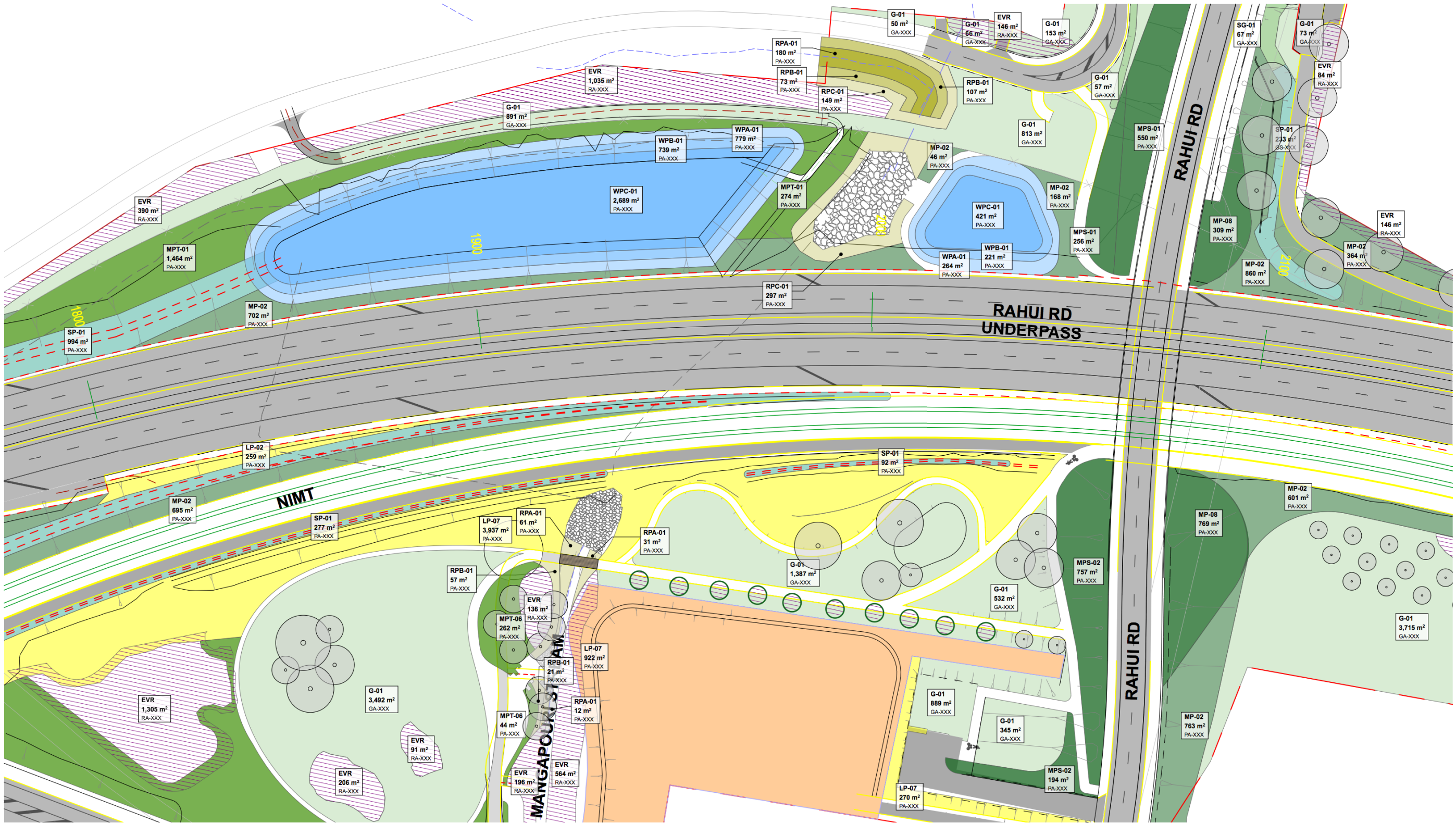

1 Stream Diversion Treatment - Mangapouri
Scale 1:1000

No.	Revision	By	Chk	Appd	Date
A	For Information	MB	SD/SH		28/06/18

Design	Drawn	Checked	Approved For Construction

Scale (A1) DOUBLE SHOWN
Scale (A3) AS SHOWN
* Refer to Original Hardcopy for Signature

ANZ TRANSPORT AGENCY **Peka Peka to Ōtaki Expressway**

Fletcher HIGGINS

BECA **Tonkin+Taylor**

Subject:	STREAM DIVERSION TREATMENTS
Title:	MANGAPOURI STREAM

CONCEPT DESIGN
NOT FOR CONSTRUCTION

Discipline:	GENERAL
Drawing No.:	PP20-SK-GN-0281
Rev.:	A

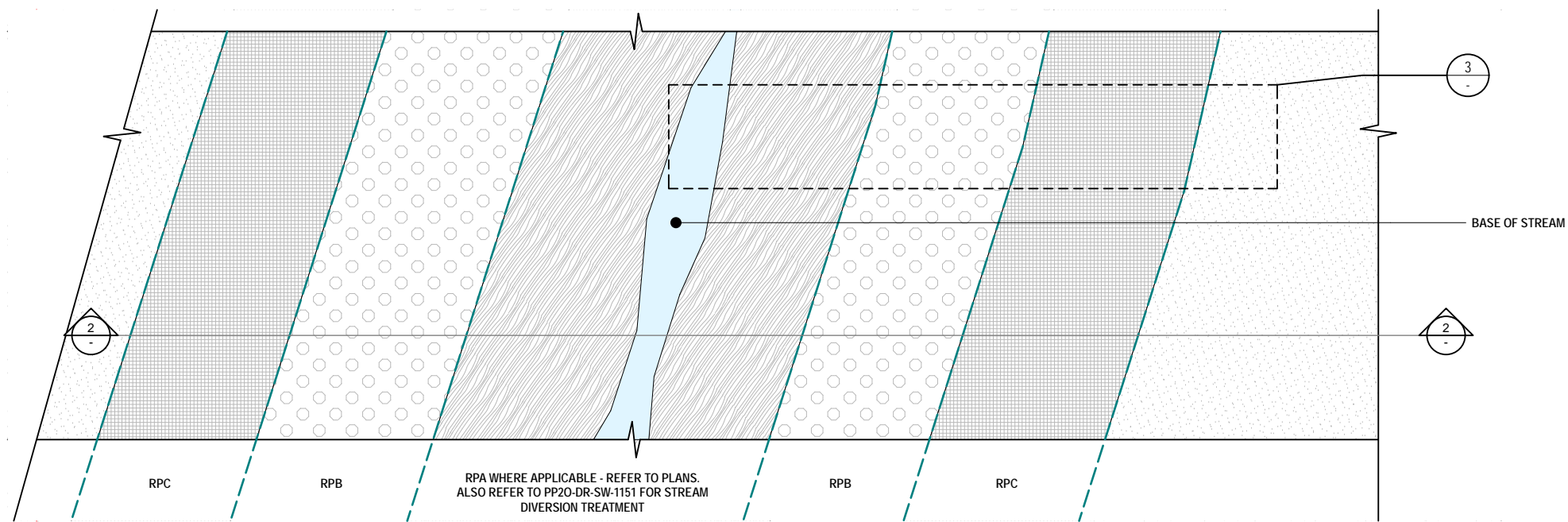

1 TYPICAL PLANTING PLAN - RIPARIAN PLANTING

Scale 1:250

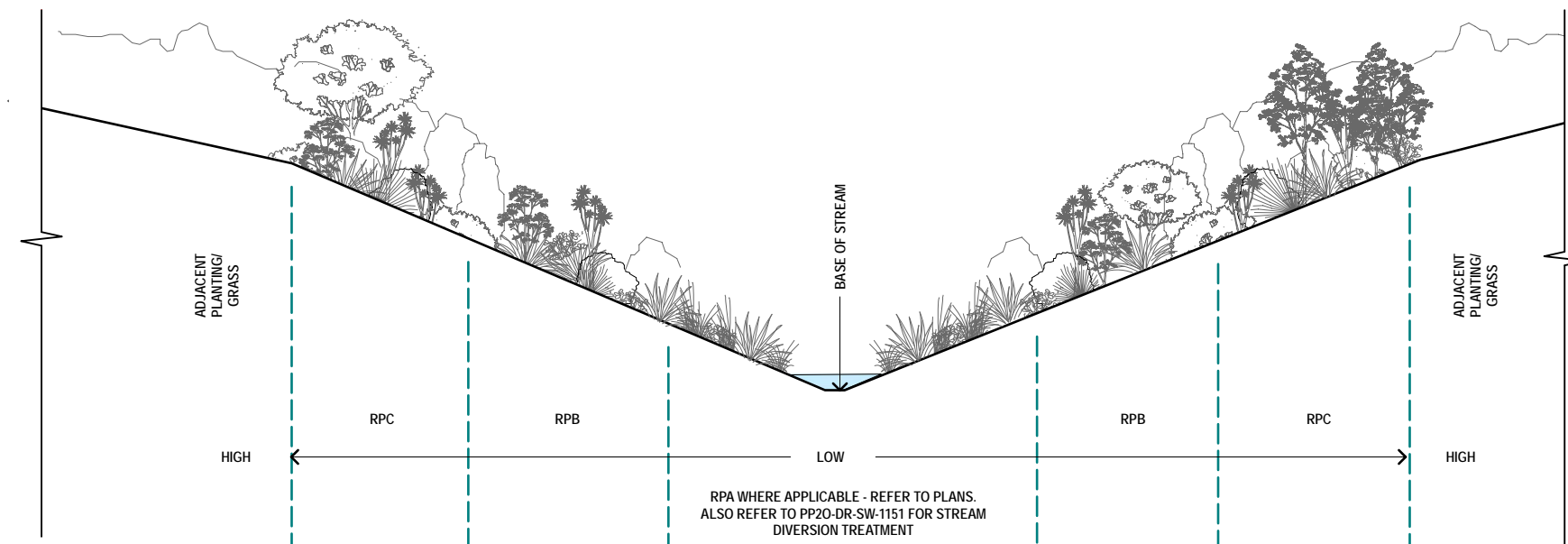

2 TYPICAL PLANTING SECTION - RIPARIAN PLANTING

Scale 1:250

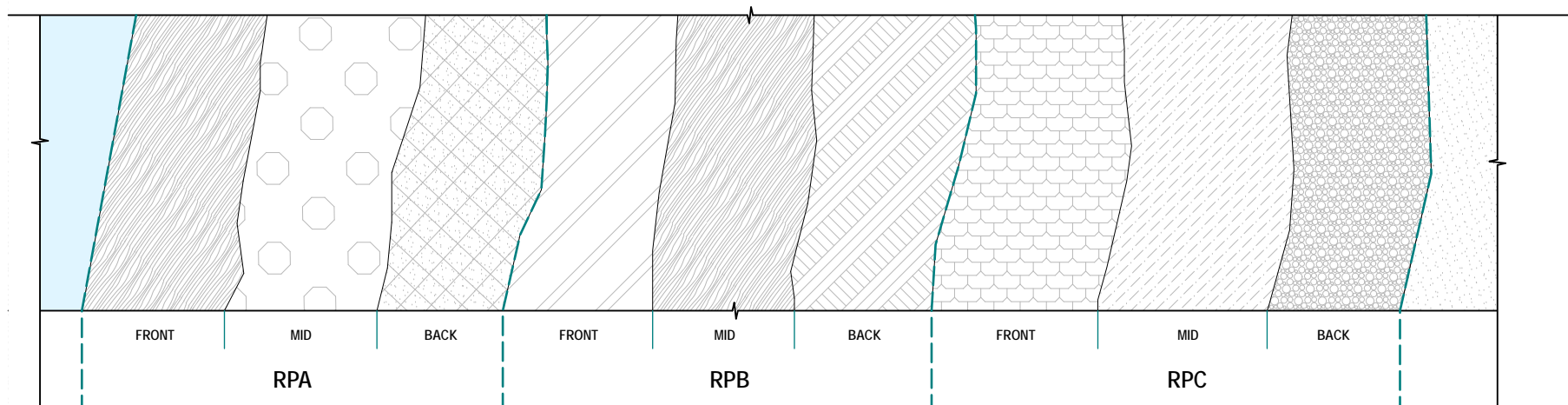

3 TYPICAL PLANTING DETAIL PLAN - RIPARIAN PLANTING

Scale 1:100

KEY:
 RPA - RIPARIAN PLANTING STANDING WATER/WATERS EDGE MIX
 RPB - RIPARIAN PLANTING LOWER BANK MIX
 RPC - RIPARIAN PLANTING UPPER BANK MIX

NOTES:
 1. DRAWINGS TO BE READ IN CONJUNCTION WITH PLANTING PLANS, PLANTING SCHEDULES, TYPICAL PLANTING DETAILS AND LANDSCAPE SPECIFICATIONS

2. CONFIRM SETOUT WITH LANDSCAPE ARCHITECT PRIOR TO PLANTING

3. PLANT IN NATURAL CLUSTERS OF ODD NUMBERS (3-11) OF A SINGLE SPECIES UNLESS SPECIFIED WITHIN PLANTING SCHEDULES OR ON PLANTING PLANS

4. GENERALLY PLANT LOWER GROWING SPECIES TOWARD THE FRONT

5. AVOID STRAIGHT LINES

6. SETOUT FROM FRONT TO BACK

7. REFER TO PP20-DR-SW-1151 FOR STREAM DIVERSION TREATMENT

Design					
Drawn					
Checked					

Subject:	STREAM DIVERSION TREATMENTS
Title:	TYPICAL PLANTING SETOUT RIPARIAN PLANTING

CONCEPT DESIGN NOT FOR CONSTRUCTION	
Discipline:	GENERAL
Drawing No.:	PP20-SK-GN-0284
Rev.:	A

Riparian Planting - A (RPA-01): Standing Water/Waters Edge					
Botanical Name	Common Name	Percentage Mix	Grade	Density (x/m2)	Notes
<i>Apodasmia similis</i>	Oioi / Jointed Wire Rush	10%	0.5L	1.8	Front/Mid
<i>Carex secta</i>	Pukio	10%	0.5L	1.8	Front
<i>Carex virgata</i>	Pukio	10%	0.5L	1.8	Front
<i>Coprosma tenuicaulis</i>	Swamp Coprosma	10%	PB2	1	Back
<i>Cyperus ustulatus</i>	Giant Umbrella Sedge	20%	0.5L	1	Front/Mid
<i>Ficinia nodosa</i>	Knobby Club Rush	10%	0.5L	1.8	Front/Mid
<i>Phormium tenax</i>	NZ Swamp Flax	30%	PB2	1	Mid

Riparian Planting - B (RPB-01): Lower Bank					
Botanical Name	Common Name	Percentage Mix	Grade	Density (x/m2)	Notes
<i>Apodasmia similis</i>	Oioi / Jointed Wire Rush	3%	0.5L	1.8	Front/Mid
<i>Carex dipsacea</i>	Autumn Sedge	4%	PB2	1.8	Front
<i>Carex secta</i>	Pukio	4%	0.5L	1.8	Front
<i>Carex virgata</i>	Pukio	4%	0.5L	1.8	Front
<i>Coprosma tenuicaulis</i>	Swamp Coprosma	8%	PB2	1	Mid
<i>Cordyline australis</i>	Cabbage Tree	6%	PB2	1	Mid
<i>Cortaderia fulvida</i>	Toetoe	20%	PB2	1	Front/mid
<i>Cyperus ustulatus</i>	Giant Umbrella Sedge	8%	0.5L	1	Front/Mid
<i>Hebe stricta</i>	Koromiko	10%	PB2	1	Mid
<i>Ficinia nodosa</i>	Knobby Club Rush	3%	0.5L	1.8	Front/Mid
<i>Phormium tenax</i>	NZ Swamp Flax	30%	PB2	1	Mid

Riparian Planting - C (RPC-01): Upper Bank					
Botanical Name	Common Name	Percentage Mix	Grade	Density (x/m2)	Notes
<i>Carex dipsacea</i>	Autumn Sedge	5%	PB2	1.8	Front
<i>Carex geminata</i>	Rautahi	5%	0.5L	1.8	Mid
<i>Coprosma propinqua</i>	Mingimingi	5%	PB2	1	Mid
<i>Cordyline australis</i>	Cabbage Tree	3%	PB2	1	Mid
<i>Cortaderia fulvida</i>	Toetoe	15%	PB2	1	Front/mid
<i>Hebe stricta</i>	Koromiko	10%	PB2	1	Mid
<i>Olearia paniculata</i>	Akiraho	12%	PB2	1	Mid
<i>Phormium tenax</i>	NZ Swamp Flax	25%	PB2	1	Mid
<i>Pittosporum tenuifolium</i>	Kohuhu	15%	PB2	1	Mid/Back
<i>Plagianthus regius</i>	Ribbonwood	5%	PB2	1	Back

No.	Revision	By	Chk	Appd	Date
A	For Information	MB	SD/SH		28/06/18

Scale (A1) SHOWN	Design	Drawn	Approved For Construction
Scale (A3) AS SHOWN <td>Design</td> <td></td> <td>Date</td>	Design		Date
	Dwg Verifier		
	Dwg Check		

* Refer to Original Hardcopy for Signature

NZ TRANSPORT AGENCY Peka Peka to Ōtaki Expressway

Fletcher HIGGINS

BECA **Tonkin+Taylor**

Subject:	STREAM DIVERSION TREATMENTS
Title:	RIPIARIAN PLANT MIXES

CONCEPT DESIGN
NOT FOR CONSTRUCTION

Discipline:	GENERAL
Drawing No.:	PP20-SK-GN-0285
Rev.:	A

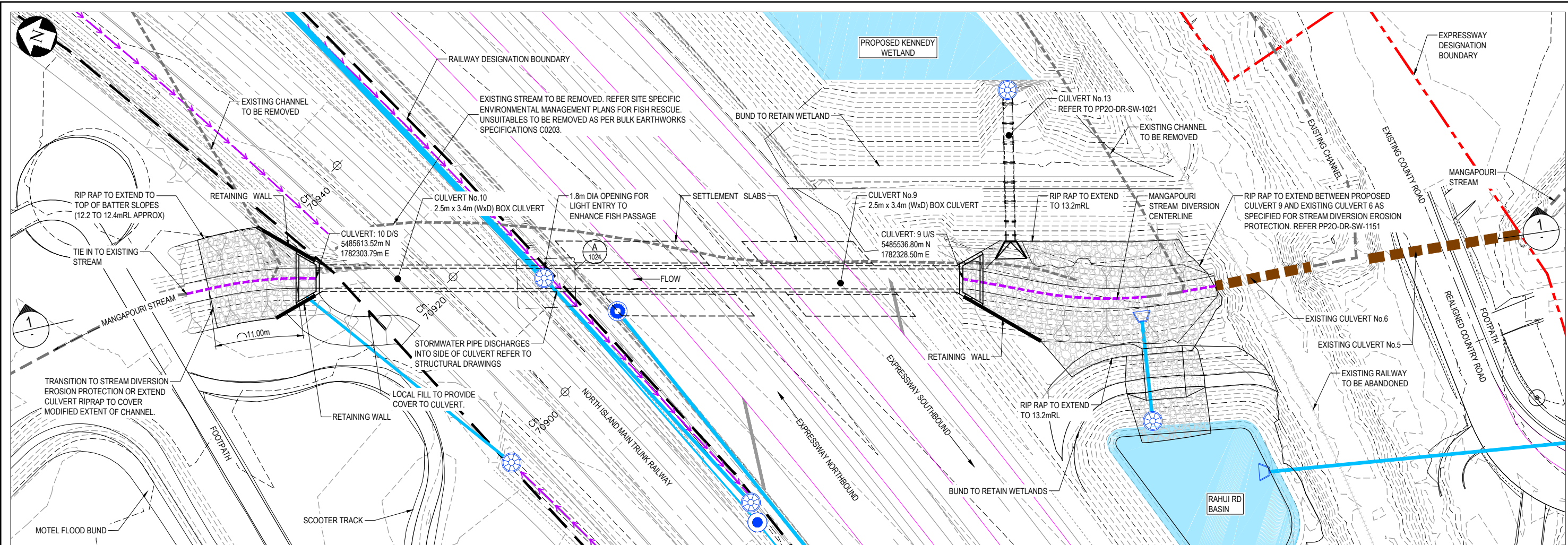

PLAN - LAYOUT
SCALE: 1:250 (A1) 1:500 (A3)

- NOTES:**
- FOR STRUCTURAL DETAILS FOR CULVERT BARREL AND HEADWALLS, REFER STRUCTURAL DRAWINGS PP20-DR-SC-0900-0933.
 - FOR LONGITUDINAL DRAINAGE REFER TO DRAWINGS PP20-DR-SW-0101 TO 0147 AND PP20-DR-SW-0201 TO 0237.
 - FISH PASSAGE PROVIDED BY EMBEDDING CULVERT IN STREAM BED. SUBSTRATE TO BE PLACED IN CULVERT DURING CONSTRUCTION AND TO MATCH EXISTING STREAM BED MATERIAL. AVERAGE DEPTH OF SUBSTRATE TO BE 0.5m, SLOPING AT 1V:10H ACROSS CULVERT BARREL TO ENHANCE LOW FLOW DEPTH. SLOPED CONCRETE END SILL AT DOWNSTREAM WINGWALL TO SUPPORT SUBSTRATE RETENTION. REFER TO DRAWINGS PP20-DR-SW-1001-1004 FOR RIPRAP SIZING AND DETAILS.
 - COVER MEASURED FROM FINISHED SURFACE TO OUTSIDE OF BOX CULVERT.

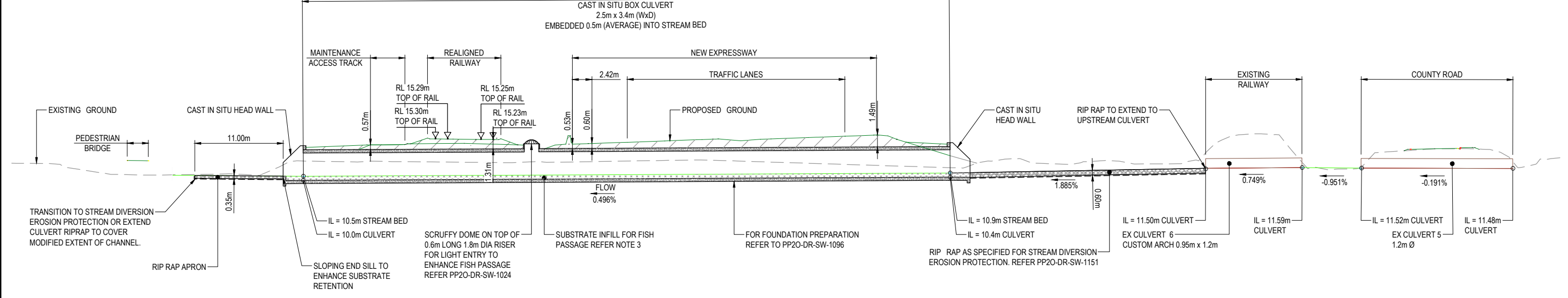

1 LONGITUDINAL SECTION
SCALE: 1:250 (A1) 1:500 (A3)

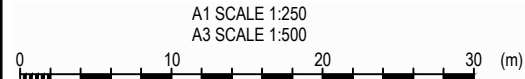

FOR CONSTRUCTION
ORIGINAL IN COLOUR

No.	Revision	By	Chk	Appd	Date
1	ISSUED FOR CONSTRUCTION (CULVERTS)	LA	DK	SW	29.06.18

Design	A. Houldsworth	15.12.17	Approved For Construction	S. Waters
Drawn	S. Halliday	24.07.17		
Dig Verifier	T. Bassett	29.06.18		
Dig Check	D. Knappstein	29.06.18	Date	02.07.18

* Refer to Original Hardcopy for Signature

NZ TRANSPORT AGENCY | **Peka Peka to Otaki Expressway** | **Fletcher HIGGINS** | **BECA** | **Tonkin+Taylor**

Subject:	CULVERTS	Discipline:	STORMWATER
Title:	CULVERTS 9 & 10 (CH 2,000, MANGAPOURI STREAM) PLAN AND LONGITUDINAL SECTION	Drawing No.:	PP20-DR-SW-1023

Rev.	1
------	---

Document No. R3000 - DESIGN DEVELOPMENT GENERAL USE CAD/DRAWINGS/PP20-DR-SW-1023-1024.DWG

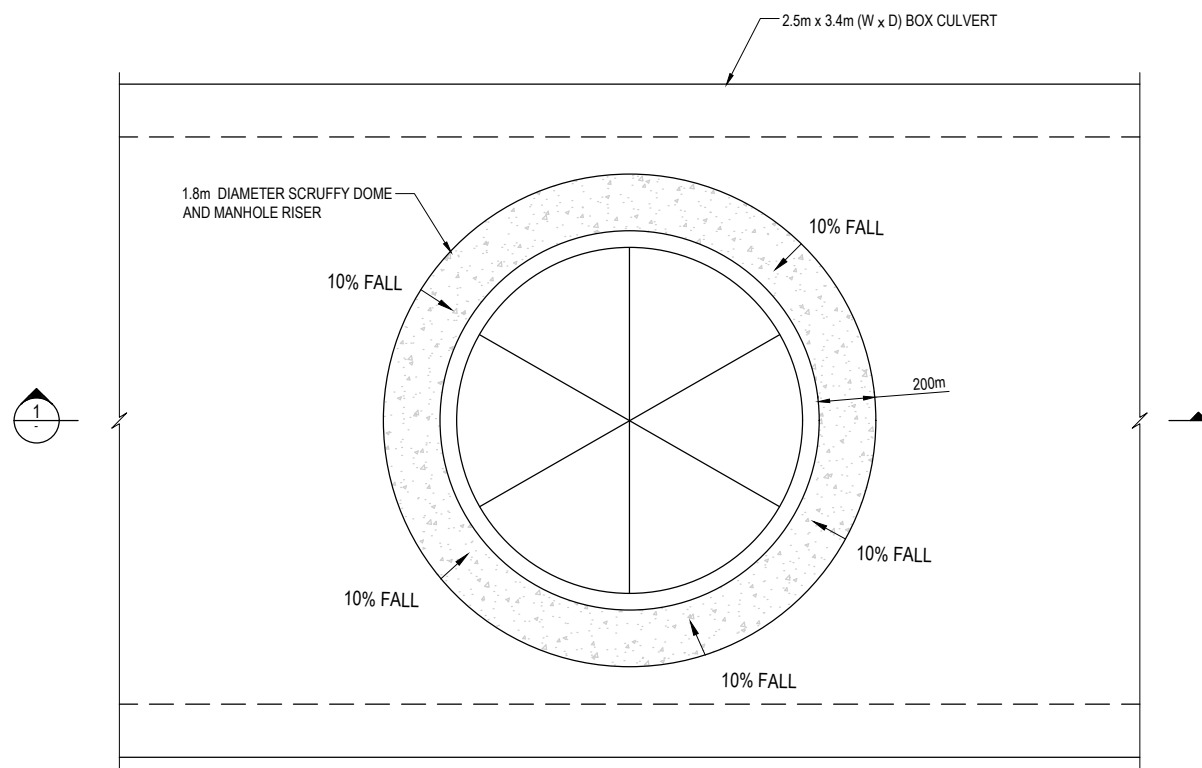

A DETAIL CULVERT 9 AND 10 SCRUFFY DOME FOR LIGHT ENTRY
1023 1:20

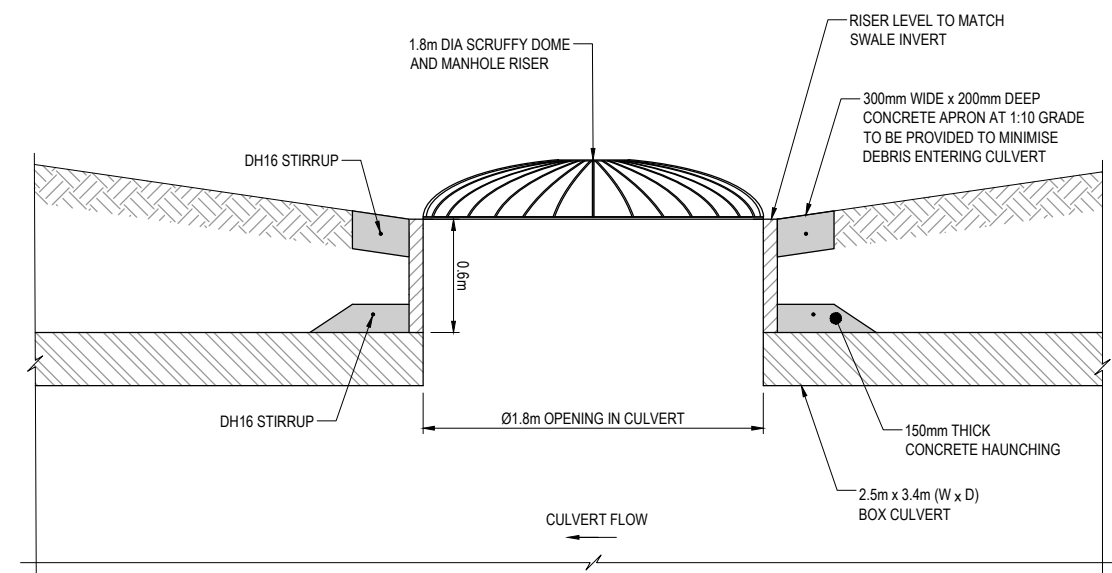

1 SECTION CULVERT 9 AND 10 SCRUFFY DOME FOR LIGHT ENTRY
1:20

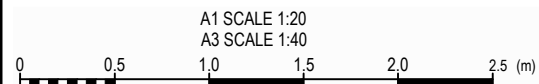

ORIGINAL IN COLOUR

FOR CONSTRUCTION

No.	Revision	By	Chk	Appd	Date
1	ISSUED FOR CONSTRUCTION (CULVERTS)	LA	DK	SW	29.06.18

Scale (A1)	Design	A.Houldsworth	15.12.17	Approved For Construction
1:20	Drawn	S.Halliday	24.07.17	S.Waters
	Eng Verifier	T.Bassett	29.06.18	
Scale (A3)	Eng Check	D.Knapstein	29.06.18	Date 02.07.18
1:40	* Refer to Original Hardcopy for Signature			



Peka Peka to Otaki Expressway



Subject:	CULVERTS	Discipline:	STORMWATER
Title:	CULVERTS 9 & 10 (CH 2000, MANGAPOURI STREAM) DETAILS	Drawing No.:	PP20-DR-SW-1024

Rev.	1
------	---

APPENDIX D – STORMWATER INFORMATION

Stormwater Review

Mangapouri Stream Temporary Diversion Culvert

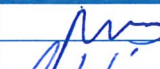
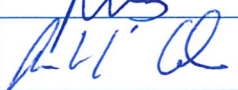
Name	Signed	Date
Hamish Smith		18/5/2018
Richard Cole		18/5/2018

Comments
<p>A diversion channel is required for the construction of the permanent expressway culvert on the Mangapouri stream. A temporary cross of the diversion channel will also be required.</p> <p>The arrangement shown in Figure 1 was initially proposed, with the channel sized for a 2 year ARI flood discharge.</p> <p>A crossing would necessitate a culvert, which will result in additional energy losses, and hence higher water levels backing up behind the culvert, therefore a larger channel will also be required.</p> <p>We propose the following arrangement of culvert and channel sized for a 2 year ARI flood discharge of 7.7m³/s:</p> <p>A twin 1200mm diameter culvert to with a 1.3m deep, 2.6m wide channel with 1:1.5 side slopes. This allows for 200mm culvert embedment for fish passage too.</p>

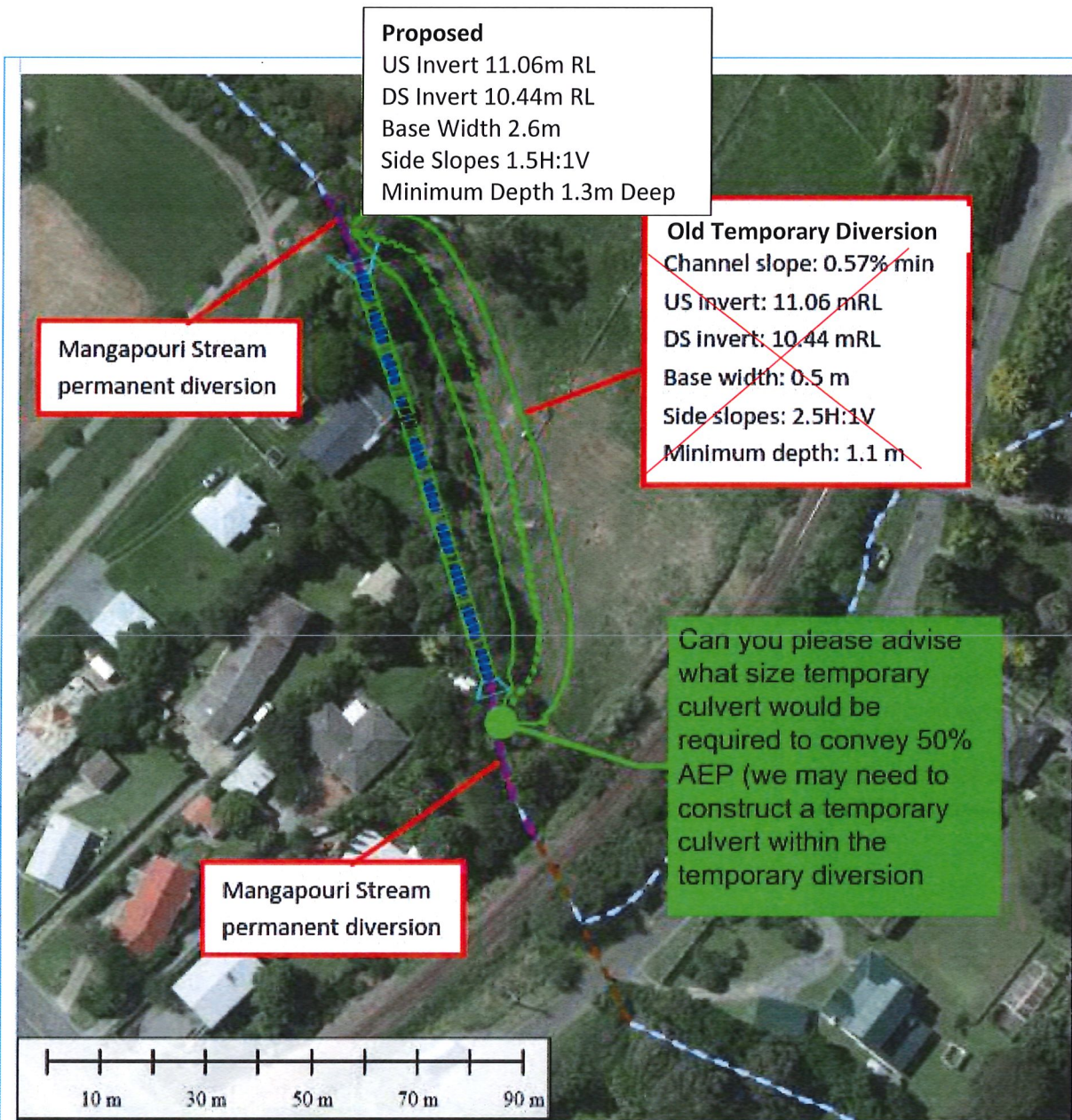

Levels in terms of NZVD 2009

Figure 1: Initially proposed arrangement without culvert crossing.

APPENDIX E: PROGRAMME

Activity Name	Orig Dur	Rem Dur	Start	Finish	2018					2019									
					Jun	Jul	Aug	Sep	Oct	Nov	Dec	Jan	Feb	Mar	Apr	May	Jun	Jul	
Peka Peka to Otaki Expressway	310d	237d	02-Feb-18 A	11-May-19															
Construction	310d	237d	02-Feb-18 A	11-May-19															
Zone 1 (North): Ch 0 - 3800	310d	237d	02-Feb-18 A	11-May-19															
Structures	310d	237d	02-Feb-18 A	11-May-19															
Bridge 4 - Rahui Road Underpass (Steel Deck)	310d	237d	02-Feb-18 A	11-May-19															
Start Bridge 4 - Rahui Road Underpass	0d	0d	22-May-18																
Bridge 4 Complete	0d	0d		11-May-19															
Enabling Works	74d	1d	02-Feb-18 A	22-May-18															
Access Track to Bridge 4	2d	0d	02-Feb-18 A	05-Feb-18 A															
Establishment of Bridge 4	1d	1d	22-May-18	22-May-18															
Construction pads for Bridge 4	1d	1d	07-May-18 A	22-May-18															
Ground Works	176d	176d	03-Jul-18	23-Mar-19															
MSE Wall	138d	138d	03-Jul-18	25-Jan-19															
West Abutment	23d	23d	03-Jul-18	02-Aug-18															
Drainage Layer West Abut. Bridge 4	3d	3d	03-Jul-18	05-Jul-18															
MSE Layers West Abut. Bridge 4	20d	20d	06-Jul-18	02-Aug-18															
East Abutment	18d	18d	05-Jan-19	25-Jan-19															
Drainage Layer East Abut. Bridge 4	3d	3d	05-Jan-19	08-Jan-19															
MSE Layers East Abut. Bridge 4	15d	15d	09-Jan-19	25-Jan-19															
Other	153d	153d	03-Aug-18	23-Mar-19															
MSE Settlement Period For West Abut. Bridge 4	57d	57d	03-Aug-18	28-Sep-18															
Backfill East Abut. Bridge 4	4d	4d	01-Feb-19	07-Feb-19															
Backfill West Abut. Bridge 4	4d	4d	08-Feb-19	13-Feb-19															
MSE Settlement Period For East Abut. Bridge 4	57d	57d	26-Jan-19	23-Mar-19															
Substructure	118d	118d	03-Aug-18	31-Jan-19															
East Abutment	14d	14d	15-Jan-19	31-Jan-19															
Construct Precast East Abut. Bridge 4	10d	10d	15-Jan-19	25-Jan-19															
Land and align precast East Abut. beam Bridge 4	4d	4d	26-Jan-19	31-Jan-19															
West Abutment	18d	18d	03-Aug-18	28-Aug-18															
Prep and Blind West Abut. Bridge 4	1d	1d	03-Aug-18	03-Aug-18															
Land Pre fabricated Reinforcing Cage West Abut. Bridge	3d	3d	06-Aug-18	08-Aug-18															
Form West Abut. Bridge 4	3d	3d	09-Aug-18	13-Aug-18															
Pour West Abut. Bridge 4	1d	1d	14-Aug-18	14-Aug-18															
Cure West Abut. Bridge 4	3d	3d	15-Aug-18	17-Aug-18															
Strip West Abut. Bridge 4	2d	2d	20-Aug-18	21-Aug-18															
Ballast wall FRP West Abut. Bridge 4	5d	5d	22-Aug-18	28-Aug-18															
Superstructure	117d	117d	30-Oct-18	01-May-19															
Beams	72d	72d	30-Oct-18	02-Feb-19															
Dress first beams delivered to Bridge 4	2d	2d	30-Oct-18	31-Oct-18															
Install Span 1 of Bridge 4	2d	2d	01-Feb-19	02-Feb-19															
Diaphragms	10d	10d	04-Feb-19	15-Feb-19															
FRP Span 1 Bridge 4	10d	10d	04-Feb-19	15-Feb-19															
Deck	32d	32d	16-Feb-19	02-Apr-19															
Steel Fit Out, Seal Deck, Form Bridge 4	5d	5d	16-Feb-19	21-Feb-19															
Tie Deck Reinforcing Bridge 4	5d	5d	22-Feb-19	27-Feb-19															
Pour Bridge 4 Deck	1d	1d	25-Mar-19	25-Mar-19															
Cure Bridge 4 Deck	7d	7d	26-Mar-19	01-Apr-19															
Strip Bridge 4 Deck	1d	1d	02-Apr-19	02-Apr-19															
Barriers	12d	12d	15-Apr-19	01-May-19															
East Abut. Transition barriers and slab Bridge 4	6d	6d	15-Apr-19	23-Apr-19															
Install Precast Barriers Bridge 4	6d	6d	24-Apr-19	01-May-19															
Barrier stitch Bridge 4	2d	2d	30-Apr-19	01-May-19															
West Abut. Transition barriers and slab Bridge 4	6d	6d	24-Apr-19	01-May-19															
Approach slabs	10d	10d	03-Apr-19	16-Apr-19															
East Abutment	8d	8d	03-Apr-19	13-Apr-19															
Blind East Abut. Approach Slab Bridge 4	1d	1d	03-Apr-19	03-Apr-19															
Tie Reinforcing East Abut. Approach Slab Bridge 4	3d	3d	04-Apr-19	06-Apr-19															
Form East Abut. Approach Slab Bridge 4	1d	1d	08-Apr-19	08-Apr-19															
Pour East Abut. Approach Slab Bridge 4	1d	1d	09-Apr-19	09-Apr-19															
Cure East Abut. Approach Slab Bridge 4	3d	3d	10-Apr-19	12-Apr-19															
Strip East Abut. Approach Slab Bridge 4	1d	1d	13-Apr-19	13-Apr-19															
West Abutment	10d	10d	03-Apr-19	16-Apr-19															
Blind West Abut. Approach Slab Bridge 4	1d	1d	03-Apr-19	03-Apr-19															
Tie Reinforcing West Abut. Approach Slab Bridge 4	3d	3d	08-Apr-19	10-Apr-19															
Form West Abut. Approach Slab Bridge 4	1d	1d	11-Apr-19	11-Apr-19															
Pour West Abut. Approach Slab Bridge 4	1d	1d	12-Apr-19	12-Apr-19															
Cure West Abut. Approach Slab Bridge 4	3d	3d	13-Apr-19	15-Apr-19															
Strip West Abut. Approach Slab Bridge 4	1d	1d	16-Apr-19	16-Apr-19															
Ancillary	10d	10d	29-Apr-19	11-May-19															
Metalwork	3d	3d	29-Apr-19	01-May-19															
Install Texas Rails for Rahui Bridge	3d	3d	29-Apr-19	01-May-19															
Miscellaneous	9d	9d	02-May-19	11-May-19															
Patching Bridge 4	2d	2d	02-May-19	03-May-19															
Mastics Bridge 4	2d	2d	04-May-19	06-May-19															
Coatings Bridge 4	2d	2d	07-May-19	08-May-19															
Dis-establishment Bridge 4	3d	3d	09-May-19	11-May-19															
Surfacing	2d	2d	02-May-19	03-May-19															
Pre-level Bridge 4	1d	1d	02-May-19	02-May-19															
Asphalt Bridge 4 (728m2)	1d	1d	03-May-19	03-May-19															
Bridge 4 Trafficable	0d	0d		03-May-19															

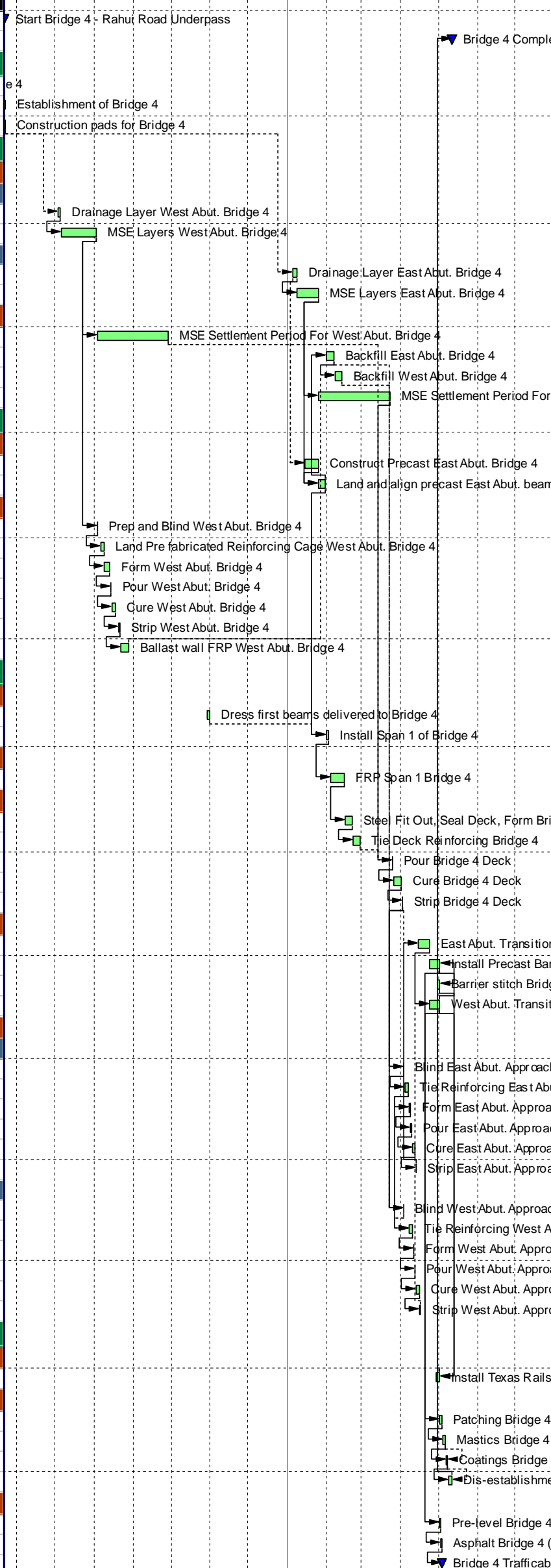

Peka Peka to Otaki Bridge 4 Programme

- Remaining Level of Effort
- Actual Level of Effort
- Actual Work



APPENDIX F: SSTMP

Site Specific Traffic Management Plan – Peka to Ōtaki Project

Rahui Road Underpass (Bridge 4)

June 2018

Contents

1 INTRODUCTION	3
1.1 The SSTMP and TMP Process	4
2 SSTMP CONSENT CONSIDERATIONS	5
2.1 Proposed Temporary Traffic Management Measures - BOI condition 34 b (i).....	5
2.2 Assessment of delays - BOI condition 34 b (ii).....	5
2.3 Detour Routes - BOI condition 34 b (iii)	5
2.4 Existing Accesses - BOI condition 34 b (iv)	5
2.5 Pedestrian and Cyclist Access - BOI condition 34 b (v)	5
2.6 Maintaining Existing Transport Services - BOI condition 34 b (vi)	6
2.7 Temporary Speed Limits (TSL) - BOI condition 34 b (vii).....	6
2.8 Access to & From the Construction Site - BOI condition 34 b (viii)	6
2.9 Communications and Stakeholders - BOI condition 34 b (ix)	6
3 ADDITIONAL CTMP CONSIDERATIONS.....	6
3.1 Kiwirail NIMTR - CTMP section 2.1.2.....	6
3.2 Emergency Action Plan(s) – CTMP section 3.2.3.8.....	7
3.4 Monitoring, Auditing & Reporting – CTMP sections 3.3 & 3.4	7
3.5 Complaints – CTMP sections 3.5	7

1 INTRODUCTION

This Site Specific Traffic Management Plan (SSTMP) provides the necessary information to demonstrate how the project team plan to avoid or mitigate potential construction traffic effects from activities associated with the construction of the Rahui Road Underpass (Bridge 4).

This SSTMP reflects the requirements of the Construction Traffic Management Plan (CTMP) including sections 1.3 (Performance Standards) and section 3.2.1 - specifically the need to interface with TTM on other networks. This plan is also consistent with the requirements set out in the over-arching Construction Environmental Management Plan (CEMP).

This document is intended to be utilised by the construction team to clearly identify any site specific traffic management requirements that must be adhered to prior to, and during works in any given area.

The temporary traffic management required to carry out these works across the site will consist of various types of Temporary Closures including, but not limited to, Site Access, Shoulder, Footpath, Stop/Go, Contra Flow and Temporary Concrete Barrier installations with works undertaken on Local Roads as covered by this SEMP.

Specific Traffic Management methodologies will be finalised and submitted to the relevant Road Controlling Authority as the construction programme is finalised and becomes more detailed. These more specific Traffic Management Plans (TMPs) will cover specific mitigation for each individual temporary traffic management requirement. This document will be a living document that will have multiple stages and traffic layouts that will be amended as and when required to suit varying construction stages and required traffic management.

1.1 The SSTMP and TMP Process

This SSTMP provides the necessary information from a project level on how the effects of construction traffic related to the site activities will be avoided or mitigated across the two roading networks in the location of the expressway works i.e. the State Highway Network (NZTA) and the local road network (KCDC)

Each of the two Road Controlling Authorities (RCA's) has its own processes and procedures for the approvals (TMP's) and implementation of temporary Traffic management within their respective networks which is separate to the SSTMP process.

It is recognised that approval / implementation of TMPs associated with this SSTMP will be staged and implemented at differing times over the course of the works. In addition, it is recognised that the TMP's themselves may alter due to both project and surrounding community requirements.

The purpose of this SSTMP is to provide the base (minimum) standard of service / maximum practical level of mitigation to be incorporated into the development of the respective TMP's all the while ensuring that the BOI consent conditions and subsequent CTMP requirements are met during the construction process.

2 SSTMP CONSENT CONSIDERATIONS

Reference should also be made to section 3.2 of the CTMP.

2.1 Proposed Temporary Traffic Management Measures - BOI condition 34 b (i)

Each of the work areas will have the required (CoPTTM) signage and early warning delineation provided by a combination of cones and line marking – all in accordance with the respective RCA TMP requirements. Each Traffic Management Plan will be submitted to the relevant RCA and Approved prior to implementation. Until site specific construction plans are finalised a location specific Traffic Management Plan cannot be prepared. Once methodologies are finalised location specific Traffic Management plans will be prepared and submitted to KCDC for approval.

2.2 Assessment of delays - BOI condition 34 b (ii)

Each Traffic Management plan will incorporate an assessment of expected delays and will also provide delay calculations where any are expected to occur. It is not envisaged that any significant delays will occur at any time.

Any oversized loads will be escorted with Pilot Vehicles again with no anticipated delays with their operations covered by Oversized Vehicle Permits. These oversized movements will be of an occasional nature only to move large plant in and off site.

2.3 Detour Routes - BOI condition 34 b (iii)

Detours will be required during various phases of works in this area. Sequencing of traffic management during the initial phase of works (Bridge 4 western abutment) is demonstrated in the attached drawings. As the works progress, the necessary TMPs will be submitted to KCDC for approval.

2.4 Existing Accesses - BOI condition 34 b (iv)

The proposed Temporary Traffic Management measures do not knowingly affect existing accesses to private or commercial properties. Should this occur consultation will be undertaken with affected parties to ensure they retain access at all times.

2.5 Pedestrian and Cyclist Access - BOI condition 34 b (v)

Detours will be required during various phases of works in this area. Sequencing of traffic management during the initial phase of works (Bridge 4 western abutment) is demonstrated in the attached drawings. As the works progress, the necessary TMPs will be submitted to KCDC for approval.

2.6 Maintaining Existing Transport Services - BOI condition 34 b (vi)

The proposed Temporary Traffic Management measures for implementation of the work areas will not affect any existing public transport services and facilities such as bus stops.

2.7 Temporary Speed Limits (TSL) - BOI condition 34 b (vii)

The use of TSL's will be kept to a minimum and will be identified as and when required in Site Specific Traffic Management Plans submitted to and approved by the relevant RCA. It is expected that a Temporary Speed Limit of 30km/h will only be used during Stop Go operations or should an unsealed surface be required to be left trafficked.

2.8 Access to & From the Construction Site - BOI condition 34 b (viii)

The primary objective of this SSTMP is the planning (TMP's), approvals (RCA's) and incorporation of Site Access Points (SAP's) as outlined in this SSTMP appended to **SSEMP SLR1** to ensure the safe and efficient access to and from site of construction related traffic.

The operating hours of the SAP's will be in accordance with the proposed hours of work included within the **CNVMP i.e.**

- Monday to Friday 6.30am to 8pm
- Saturday 7.30am to 6pm

Operation outside those hours will be at the approval of the Engineer and in accordance with the provisions of the **CNVMP**.

2.9 Communications and Stakeholders - BOI condition 34 b (ix)

As the effects of the proposed measures are as yet unknown, implementation and operation of the SSTMP's will be communicated to stakeholders, road users and the community via the methods and processes as included within the project Stake Holder and Communications Management Plan, with particular emphasis on the key groups identified in Section 3.1 of the CTMP as required.

3 ADDITIONAL CTMP CONSIDERATIONS

3.1 Kiwirail NIMTR - CTMP section 2.1.2

The implementation and operation of some SSTMP's may involve the need to collaborate with Kiwirail as sites may cross the NIMT Railway or existing at grade carriageway crossings. Traffic Management strategies will include having no delays created for Kiwirail and the NIMT.

3.2 Emergency Action Plan(s) – CTMP section 3.2.3.8

All emergency services shall have unimpeded access along all State Highway and local roads 24 hrs. per day. Should any roads be affected by temporary traffic management any likely delays will be communicated prior to works to all Emergency Service Providers by way of weekly Road Works Reporting procedures as required by both RCA's. All major works that impact the roading network will have SSTMP's developed with consultation of Emergency Services.

3.3 Access to KCDC Owned and Operated Water and Waste Water Assets – CTMP section 3.2.1.1.7

Access to existing KCDC water and waste water assets will not be impeded by any SSTMP's.

3.4 Monitoring, Auditing & Reporting – CTMP sections 3.3 & 3.4

Monitoring, Auditing and Reporting of the Traffic Management Measure (once implemented) shall be in accordance with the CTMP and CoPTTM guidelines.

3.5 Complaints – CTMP sections 3.5

Feedback including complaints received related to the implementation of Temporary Traffic Management measures covered within this SSTMP shall be recorded and processed in line with the CTMP

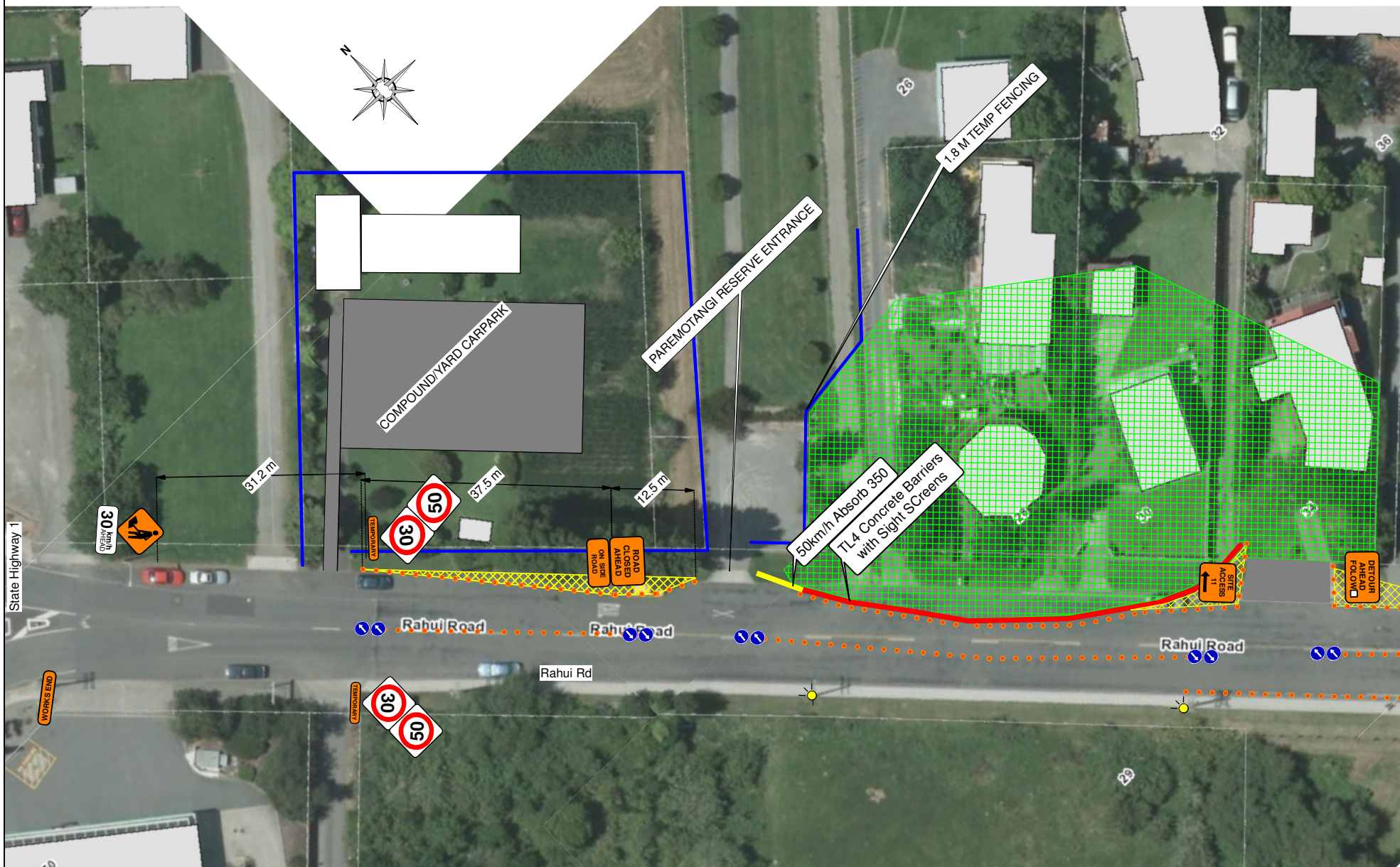

SITUATION : Civis Site Clearance Stage 1	REVISION : 1.0
DRAWING TITLE : Contraflow	DRAWING BY : Travis Medhurst
DRAWING No : P20 - -030 Sheet 1	CHECKED :
	DATE : 24/05/2018
	TMC APPROVAL :

Peka Peka to Ōtaki Expressway



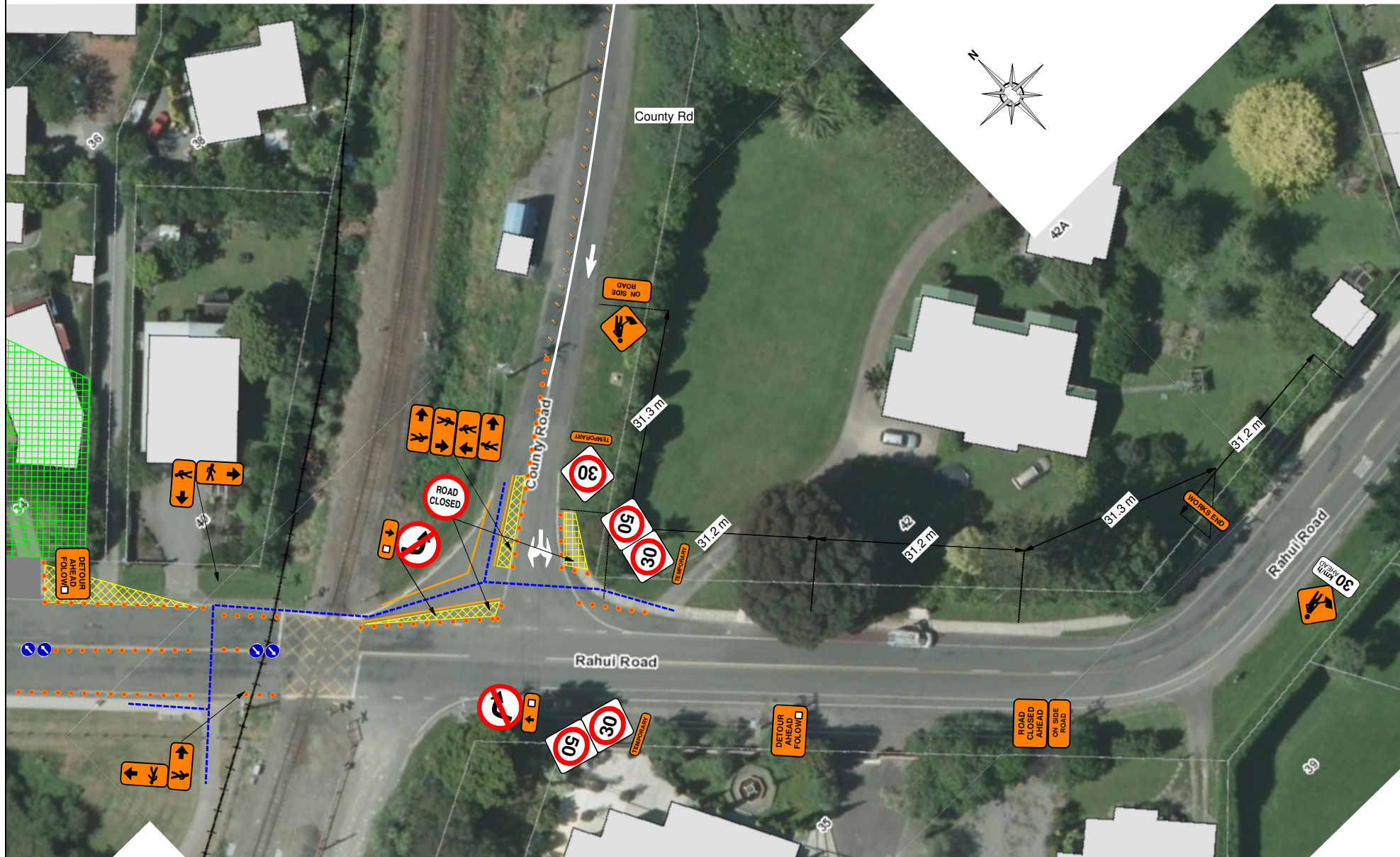

SITUATION : Civils Site Clearance Stage 1	REVISION : 1.0
DRAWING TITLE : Contraflow	DRAWING BY : Travis Medhurst
DRAWING No : P20 - 030 Sheet 2	CHECKED :
	DATE : 24/05/2018
	TMC APPROVAL :

Peka Peka to Ōtaki Expressway





WAKA KOTAHĪ



SITUATION : RE/MSE Wall Buid Rahul Rd	REVISION : 1.0
DRAWING TITLE : Contraflow	DRAWING BY : Travis Medhurst
DRAWING No : P20 - 030 Sheet 3 Stage 2	CHECKED :
	DATE : 25.05.2018
	TMC APPROVAL :

Peka Peka to Ōtaki Expressway

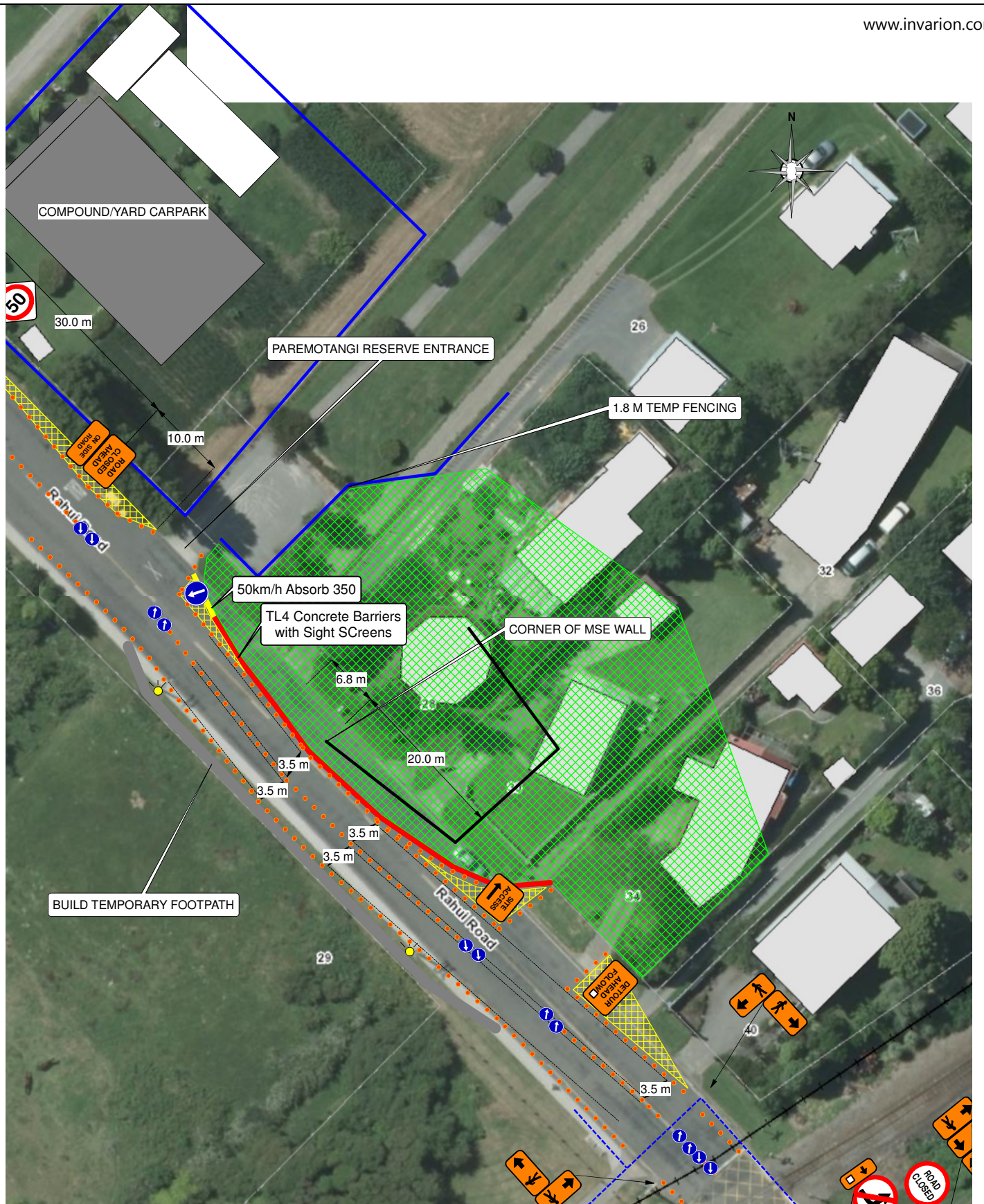



SITUATION : RE/MSE Wall Build Rahui Rd	REVISION : 1.0
DRAWING TITLE : Contraflow	DRAWING BY : Travis Medhurst
DRAWING No : P20 - 030 Sheet 4 Stage 2	CHECKED :
	DATE : 25.05.2018
	TMC APPROVAL :

Peka Peka to Ōtaki Expressway

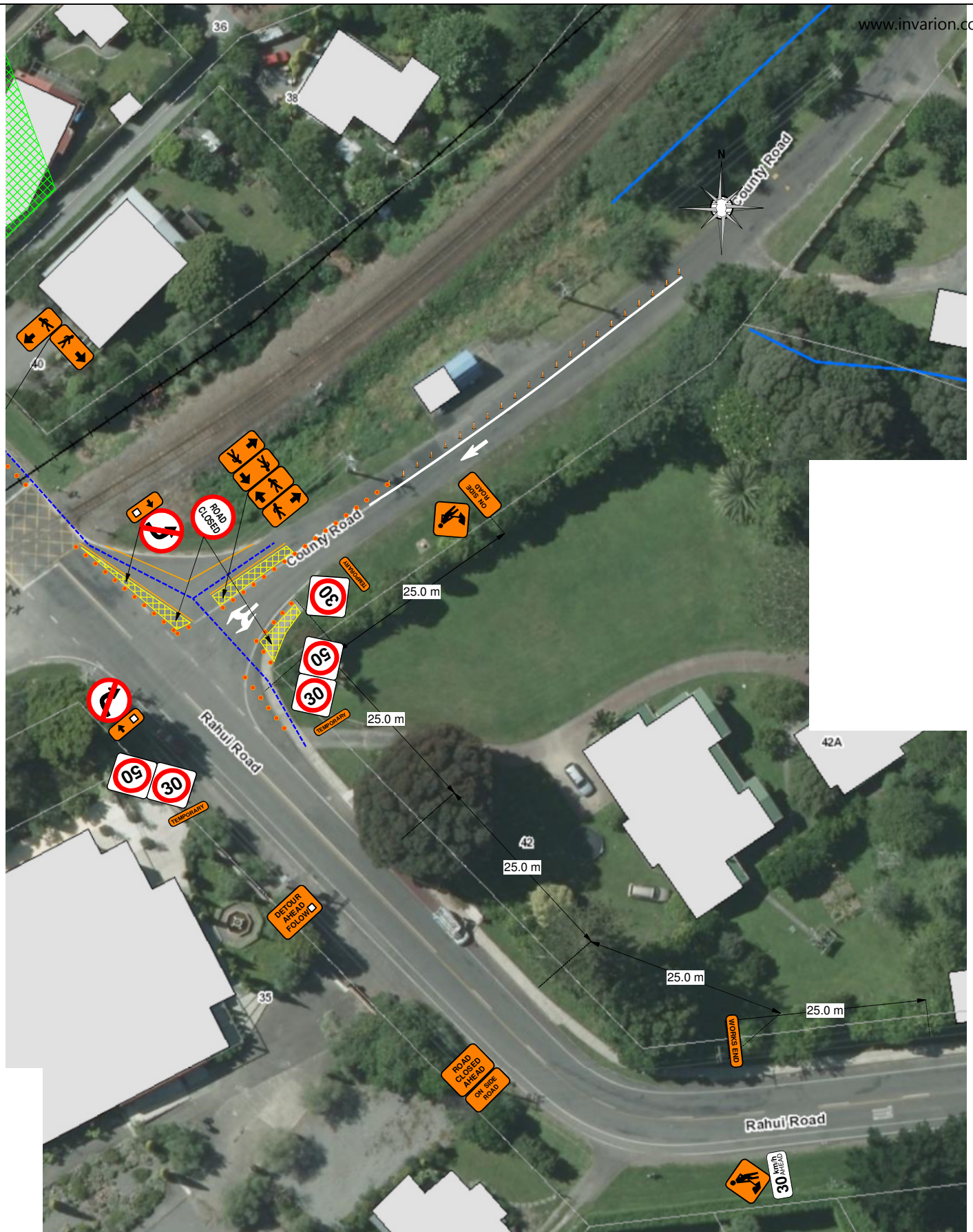

SITUATION : RE/MSE Wall Buid Rahui Rd	REVISION : 1.0
DRAWING TITLE : Contraflow	DRAWING BY : Travis Medhurst
DRAWING No : P2O - 030 Sheet 5 Stage 2	CHECKED :
	DATE : 25.05.2018
	TMC APPROVAL :

Peka Peka to Ōtaki Expressway



APPENDIX G: ABSTRACT FROM EMP – FISH MIGRATION MANAGEMENT

PP20 EMP Appendix B - Schedule of fish migration and passage requirements

Catchment	Stream name	Culvert description	Culvert No.	Chainage	Type	Size (m)	Invert Level (m NZVD (2009) Wellington)		Length (m)	Slope (%)	Stream classification	Culvert Use	Fish species / habitat	Climbing ability	Mudfish survey required	Fish passage required	Proposed Design Fish Passage Treatment	Fish Migration Management for in-stream works
							u/s	d/s										
Waitohu Stream + floodplain	Greenwood Stream	Greenwood subcatchment	1	390	Box	3.5 x 2	22.7	22.4	45	0.66	Intermittent	Stream Conveyance	Intermittent eel habitat	High	Yes	Yes	Embedded invert, grouted low flow channel	1 - To be confirmed following mudfish survey 2 - schedule works when stream is dry or minimal water is present. 3 - avoid peak upstream migration period for eels (December to March) where possible.
	Unnamed tributary of Waitohu Stream	Southern approach to Waitohu Stream bridge	3	940	Box	3 x 3 & 5 x 2	23.5	23.1	64	0.62	Intermittent	Flood Event	Intermittent eel habitat	High	No	Yes	Embedded invert, grouted low flow channel	1 - schedule works when stream is dry or minimal water is present. 2 - avoid peak upstream migration period for eels (December to March) where possible. 3 - minimise works period and undertake fish rescue.
Mangapouri Stream + Wetland System	Otaki Railway Wetland	Remnant Railway wetland connection pipe	70	1520	Circular	1.05Ø	17.3	16.96	87	0.39	Wetland connection	Wetland Connection/Outlet	Eels	High	No	Yes	For eels only. Spat rope through culvert and within the outlet structure.	1 - avoid peak upstream migration period for eels (December to March) where possible. 2 - minimise works period and undertake fish rescue.
	Otaki Railway Wetland	Remnant railway wetland culvert on connection to Kennedy Wetland	12	1680	Circular	1.05Ø	17.06	15.76	75	1.73	Wetland connection	Wetland Connection/Outlet	Eels	High	No	Yes	For eels only. Spat rope through culvert and within the outlet structure.	1 - avoid peak upstream migration period for eels (December to March) where possible. 2 - minimise works period and undertake fish rescue.
	Kennedy Wetland	Outlet from Kennedy Wetland	13	1960	Circular	0.9Ø	12.3	11.9	22	1.82	Wetland connection	Wetland Outlet	Eels	High	No	Yes	For eels only. Spat rope through culvert and within the outlet structure.	1 - avoid peak upstream migration period for eels (December to March) where possible. 2 - minimise works period and undertake fish rescue.
	Mangapouri Stream	Culvert at Expressway and Realigned railway	9 & 10	2000	Box	3 x 3	10.6	10.2	80	0.50	Permanent	Stream Conveyance	Permanent stream habitat, only eels confirmed	High	No	Yes	Minimum 0.5 m thick layer of cobbles along the culvert invert in accordance with Condition WS.4.	1 - avoid peak upstream migration period for eels (December to March) where possible. 2 - minimise works period and undertake fish rescue.
	Unnamed overland flow path	Rahul Rd overbridge	7	2080	Box	Twin 5 x 1	13.79	13	37	2.14	Ephemeral	Flood Event	None	N/A	No	No	N/A	No timing restrictions or specific ecology requirements
Racecourse Stream	Racecourse Stream	Combined Expressway / realigned railway	14	2200	Circular	1.35Ø	11.3	11.1	52	0.38	Intermittent	Stream Conveyance	Intermittent habitat, rarely flows	N/A	Yes	No	N/A	To be determined following mudfish survey
Otaki River + floodplain	Unnamed overland flow path	Existing SH1	15 (a-e)	2650 to 3000	Circular/Box	Various	-	-	-	-	Flood conveyance	Flood Event	None	N/A	No	No	N/A	No timing restrictions or specific ecology requirements
	Unnamed overland flow path	Off-channel storage basin	18	3340	Box	3.5 x 3	11.7	11.4	60	0.50	Flood conveyance	Flood Event	None	N/A	No	No	N/A	No timing restrictions or specific ecology requirements
Mangaone Stream	Mangaone Stream	Expressway	24	7250	Box	5 x 2	16.55	16.2	46	0.76	Permanent	Stream Conveyance	Diverse fish community	Low to high	No	Yes	Minimum 0.15 m thick layer of glued gravels along the culvert invert in accordance with Condition WS.4.	Peak fish migration period for the species known to be present covers most of the year. Focus to be on minimising disturbance and keeping migration pathways open
	Mangaone Stream	Local link road (Eastern side)	23	7350	Box	5 x 3.5	17.82	17.44	21	1.81	Permanent	Stream Conveyance	Diverse fish community	Low to high	No	Yes	Minimum 0.5 m thick layer of existing gravels along the culvert invert in accordance with Condition WS.4.	Peak fish migration period for the species known to be present covers most of the year. Focus to be on minimising disturbance and keeping migration pathways open
	Mangaone Stream	Local link road (Western side)	34	7250	Box	5 x 3	14.11	13.75	24	1.50	Permanent	Stream Conveyance	Diverse fish community	Low to high	No	Yes	Minimum 0.5 m thick layer of existing gravels along the culvert invert.	Peak fish migration period for the species known to be present covers most of the year. Focus to be on minimising disturbance and keeping migration pathways open
Mangaone overflow	Unnamed overland flow path	Local Link Road	27	7500	Box	5 x 2	16.4	16.2	20	1.00	Ephemeral	Flood Event	None	N/A	No	No	N/A	No timing restrictions or specific ecology requirements
	Unnamed overland flow path	Expressway	28	7500	Box	5 x 2	16	15.4	47	1.28	Ephemeral	Flood Event	None	N/A	No	No	N/A	No timing restrictions or specific ecology requirements
Gear Stream	Gear Stream	Gear culvert at Gear Rd	35	8600	Box	3.5 x 2	14.05	13.9	15	1.00	Intermittent	Stream Conveyance	Intermittent habitat, potential for mudfish	Low to high	Yes	Yes	Buried inverts sufficient	To be determined following mudfish survey
	Gear Stream	Gear culvert at Expressway	36	8620	Box	5 x 2	13.7	13.5	37	0.54	Intermittent	Stream Conveyance	Intermittent habitat, potential for mudfish	Low to high	Yes	Yes	Buried inverts sufficient	To be determined following mudfish survey
Settlement Heights	Settlement Stream	Settlement Heights	39	8920	Box	Twin 5 x 2	13.5	12.85	47	1.37	Intermittent	Stream Conveyance	Intermittent habitat for Eels and banded kokopu.	High	Yes	Yes	Embedded invert, accumulation of in-situ gravels, concentrated low flow on aprons	1 - To be confirmed following mudfish survey 2 - schedule works when stream is dry or minimal water is present. 3 - avoid peak upstream migration period for banded kokopu and eels (September to March) where possible.
Coolen Stream	Coolen Stream	Coolen culvert	42	9020	Circular	0.6Ø	14.4	14.3	35	0.29	Intermittent	Stream Conveyance	Intermittent habitat for eels	High	No	Yes	Embedded invert, accumulation of in-situ gravels, spat rope through culvert	1 - schedule works when stream is dry or minimal water is present. 2 - avoid peak upstream migration period for eels (December to March) where possible. 3 - minimise works period and undertake fish rescue.
Avatar Stream	Avatar Stream	Avatar culvert	45	9400	Circular	1.5Ø	18	16.6	52	2.69	Intermittent / Ephemeral	Stream Conveyance	Very limited	High	No	No	No specific requirements. Buried inverts sufficient	No timing restrictions or specific ecology requirements
Edwin Stream	Edwin Stream	Edwin culvert	50	9950	Circular	1.2Ø	22.1	20.2	80	2.38	Intermittent / Ephemeral	Stream Conveyance	Very limited	High	Yes	Yes	Buried inverts sufficient	To be determined following mudfish survey
Jewell Stream	Jewell Stream	Jewell culvert	53	10080	Box	Twin 2.5 x 2	20	19.2	70	1.14	Intermittent	Stream Conveyance	Intermittent habitat for Eels and banded kokopu	High	Yes	Yes	Embedded invert, accumulation of in-situ gravels, concentrated low flow on aprons	1 - To be confirmed following mudfish survey 2 - schedule works when stream is dry or minimal water is present. 3 - avoid peak upstream migration period for banded kokopu and eels (September to March) where possible.
Cording Stream	Cavallo Drain	Cavallo culvert	59	10830	Circular	1.6Ø	11.4	11	66	0.61	Ephemeral	Stream Conveyance	None	N/A	Yes	Yes	No specific requirements but dependent on slope. Buried inverts likely sufficient.	To be determined following mudfish survey
	Cording Stream	Existing road culvert	61	10970	Circular	0.45Ø	TBC	TBC	82	TBC	Ephemeral	Stream Conveyance	None	N/A	Yes	No	No specific requirements. Buried inverts sufficient.	To be determined following mudfish survey
Awatea Stream	Awatea Stream	Awatea culvert	64	11380	Box	Twin 3 x 1.5	13.25	12.85	64	0.63	Intermittent	Stream Conveyance	Intermittent habitat for eels	High	No	Yes	Embedded invert, accumulation of in-situ gravels, concentrated low flow on aprons	1 - schedule works when stream is dry or minimal water is present. 2 - avoid peak upstream migration period for eels (December to March) where possible. 3 - minimise works period and undertake fish rescue.
Kumototo Stream	Kumototo Stream	Kumototo culvert	66	11680	Circular	Twin 1.6Ø	12.15	11.75	68	0.59	Intermittent	Stream Conveyance	Intermittent habitat for eels	High	No	Yes	Embedded invert, accumulation of in-situ gravels, spat rope through culvert	1 - schedule works when stream is dry or minimal water is present. 2 - avoid peak upstream migration period for eels (December to March) where possible. 3 - minimise works period and undertake fish rescue.

APPENDIX H: ASBESTOS MANAGEMENT PLAN

Memo

To:	Genevieve Smith	Job No:	85985.007
From:	Chris Hillman	Date:	22 June 2018
cc:	Richard Rakovics		
Subject:	PP20 - Asbestos in soil management plan		

This Asbestos Contaminated Land Management Plan (ACLMP) has been prepared to provide controls additional to those within the overarching Bulk Earthworks Contaminated Land Management Plan (BECLMP) for the project¹.

This plan should be read in conjunction with the BECLMP.

This ACLMP has been prepared in accordance with:

- Reporting standards set out in the Ministry for the Environment guidelines².
- Requirements of the New Zealand Asbestos Guidelines³.

1 People with responsibilities under the plan

The roles and responsibilities relating to this plan are as detailed in Section 1.3 of the BECLMP. All contaminated land queries should be directed through Genevieve Smith (Beca). Expert advice regarding asbestos in soil shall be provided by Chris Hillman (Tonkin & Taylor Ltd).

Before work commences on an area of the site identified to contain asbestos in soils⁴, this ACLMP shall be reviewed by the works supervisor and updated as appropriate, in consultation with Beca and Tonkin & Taylor Ltd (T+T).

2 Identified locations of asbestos in soil

This ACLMP applies to works involving disturbance of asbestos-contaminated soils.

Asbestos in soils has been identified in the locations/strata detailed in Table 1.1 below.

¹ Fletcher Construction Company Ltd (June 2017) Bulk Earthworks Contaminated Land Management Plan – Peka Peka to Ōtaki Project, Ref: FCCL-EV-0005, Final C.

² Ministry for the Environment (2003) Contaminated Land Management Guidelines No 1 Reporting on Contaminated Sites in New Zealand.

³ BRANZ (2017) New Zealand Guidelines for Assessing and Managing Asbestos in Soil.

⁴ For the purposes of this ACSMP, rail ballast is considered a soil.

Table 1.1 Identified presence of asbestos in soil.

Area	Location	Strata affected	Description of affected soils	Class of asbestos removal works
Rahui Road	Drawing PP20-DR-CE-0823, Rev A – Contaminated Lands Layout Plan, Sheet 3 of 18	Surface soils and within fill	Two test pits were dug at the south-western end of the Historic Housing Area (TP 106 and TP 107): fill was encountered to 0.2m in TP 107 and to at least 0.4m in TP 106 (shells were encountered at 0.4m depth in TP 106 and so the excavation was terminated). Further test pitting across the Historic Housing Area would be required to accurately assess the depth of fill	Unlicensed Asbestos Work
Main Line	600m length of main line (approximately 300m either side of Ōtaki Station)	Ballast	Drilling of the ballast could only be undertaken at the edges of the rail line, due to KiwiRail constraints; at the edges the ballast was encountered to between 0.5m and 1.0m depth.	Unlicensed Asbestos Work
	Drawing PP20-DR-CE-0824 and 0825, Rev A - Contaminated Lands Layout Plan, Sheet 4 and 5 of 18. Hotspot within ballast approximately 300m north-east of Ōtaki Station Drawing PP20-DR-CE-0824, Rev A – Contaminated Lands Layout Plan, Sheet 4 of 18.			Class B
Ōtaki Sidings	Drawing PP20-DR-CE-0824, Rev A – Contaminated Lands Layout Plan, Sheet 4 of 18	Asbestos was identified within the fill at the sidings	The fill was encountered to between 0.5m and 1.0m depth in the test pits.	Unlicensed Asbestos Work

The asbestos in soils was identified through site investigation works. Full details of the site investigation works undertaken are provided in Site Investigation Report⁵

3 Site general requirements

3.1 Unlicensed Asbestos Work Areas

- Supervision: by a competent person (as defined by the Asbestos Regulations) experienced in working with and identifying potential asbestos.
- Induction: Workers, and particularly the Competent Person supervising, should be aware that unexpected contamination could be encountered during the works. The

⁵ Tonkin & Taylor Ltd (June 2018) Peka Peka to Ōtaki Expressway – Asbestos in Soil Ground Investigation, prepared on behalf of Fletcher Construction Company Ltd.

Competent Person should be able to identify potential asbestos if unexpected materials are encountered.

- PPE: No asbestos-specific PPE required
- Air Monitoring: Monitoring for the presence of asbestos in air not required.
- Decontamination:
 - Personnel: Designated footwash and PPE collection area to be established.
 - Vehicles: Wash (low pressure) soil from vehicles before crossing over into the uncontaminated area – to be checked by visual inspection by competent person on completion.

3.2 Class B Work Area

Controls for the Class B Work Area shall be:

- Supervision: by a Class B Removalist, who will need to develop an Asbestos Control Plan for the works based on this Site Management Plan.
- Worker precautions:
 - Disposable overalls, rated type 5.
 - Nitrile gloves, category 3.
 - Gumboots (steel capped) or safety footwear with disposable overshoes.
 - Half-face P3 respirator with particulate filter.
 - HEPA filter system on vehicles.
- Air Monitoring: Monitoring for the presence of asbestos in air not required.
- Decontamination:
 - Personnel: Basic decontamination tent and footwash to be established.
 - Vehicles: as for Unlicensed Asbestos Works areas.

4 Excavation

In addition to the requirements of Section 4.2 of the BECLMP:

The following controls shall apply to both Unlicensed Asbestos Work and Class B Work Areas:

- Sediment discharges: Sediment collected by erosion and sediment control measures shall be treated as contaminated with asbestos.
- Dust control: ensure that asbestos-contaminated soils are kept damp, so that no dust is created. Care should be taken so that run-off is minimised. In the Class B Work Area, water suppression shall be employed with the use of polymer.

5 Offsite transportation of contaminated materials

In addition to the requirements of Section 4.5 of the BECLMP, soils contaminated with asbestos shall be wetted down and transported in covered trucks.

If transported outside the designation, soils contaminated with asbestos from the Class B Area shall be wrapped and sealed with 200µm heavy-gauge polythene and truck covered. Soils from the Unlicensed Asbestos Works Areas may need to be wrapped, dependent on the requirements of the receiving site.

6 Disposal of contaminated materials

6.1 Disposal within the designation

If disposed within the designation, the following requirements apply:

- Materials from Unlicensed Asbestos Works Areas - No special finishing/cover requirements. However, it would be prudent to keep these soils separate from uncontaminated soils as their location needs to be recorded (refer to Section 0).
- Materials from Class B Works Area - Ballast to be placed at a stable batter and capped with either:
 - Hardstanding (200mm thickness minimum), or
 - Geotextile beneath at least 0.5m of clean soil.

6.2 Disposal outside the designation

If removed from the designation, asbestos-contaminated soil is to be disposed as asbestos waste to a facility approved by the appropriate Territorial Authority to receive that type of waste.

7 Disposal of impacted water

Contain runoff within the work area during rainfall events and allow to soak away. Alternatively water can be collected for disposal at an appropriate off-site facility.

8 Clearance and validation testing

In addition to the requirements of Section 4.8 of the BECLMP:

- Visual assessment of vehicles shall be undertaken by a competent person before demobilisation. No special testing required.
- Swab samples are to be taken from vehicles before demobilisation from the Class B Work Area by an independent competent person, i.e. a person other than the removalist (no swab samples required from the Unlicensed Asbestos Works Areas). The removalist will also need to prepare a clearance certificate.

9 Procedures for detailing incidents or emergencies involving asbestos in the workplace

See section 5.0 of the BECLMP.

10 Ongoing monitoring and management

In accordance with the Asbestos Regulations the location of all soils containing asbestos will need to be recorded in an asbestos management plan (AMP). For the ballast sourced from the Class B Works Area, the AMP shall include procedures to ensure the future integrity of the capping.

NZTA will be responsible for ongoing management plans for materials within the NZTA maintenance/operational boundary. Where land is passed back to KiwiRail, then management plans are likely to pass back as well.

11 Applicability

This report has been prepared for the exclusive use of Fletcher Construction Company Ltd with respect to the particular brief given to us and it may not be relied upon in other contexts or for any other purpose, or by any person other than our client, without our prior written agreement.

Recommendations and opinions in this memo are based on the testing data. The nature and continuity of subsoil away from the test locations are inferred and it must be appreciated that actual conditions could vary from the assumed model.

22-Jun-18

t:\wellington\projects\85985\85985.0070\7001 environmental contaminated land\issueddocuments\smp\smp 20180614 final.docx

Asbestos in Soil Ground Investigation

Peka Peka to Ōtaki Expressway –Asbestos in Soil Ground Investigation

June 2018

Revision 3

Copyright information

This publication is copyright © NZ Transport Agency. Material in it may be reproduced for personal or in-house use without formal permission or charge, provided suitable acknowledgement is made to this publication and the NZ Transport Agency as the source. Requests and enquiries about the reproduction of material in this publication for any other purpose should be made to:

Manager, Information
NZ Transport Agency
Private Bag 6995
Wellington 6141

The permission to reproduce material in this publication does not extend to any material for which the copyright is identified as being held by a third party. Authorisation to reproduce material belonging to a third party must be obtained from the copyright holder(s) concerned.

Disclaimer

The NZ Transport Agency has endeavoured to ensure material in this document is technically accurate and reflects legal requirements. However, the document does not override governing legislation. The NZ Transport Agency does not accept liability for any consequences arising from the use of this document. If the user of this document is unsure whether the material is correct, they should refer directly to the relevant legislation and contact the NZ Transport Agency.

More information

NZ Transport Agency
August 2017

ISBN [number]

If you have further queries, call our contact centre on 0800 699 000 or write to us:

NZ Transport Agency
Private Bag 6995
Wellington 6141

This document is available on the NZ Transport Agency's website at www.nzta.govt.nz

REVISION HISTORY

Revision N°	Prepared By	Description	Date
1.	Natalie Pilcher	First issue	02.02.18
2.	Natalie Pilcher	Second issue	18.5.18
3.	Chris Hillman	Third issue	01.06.18

DOCUMENT ACCEPTANCE

Action	Name	Signed	Date
Prepared by	Natalie Pilcher		01.06.18
Reviewed by	Chris Hillman		01.06.18
Approved by	Bruce Symmans		01.06.18

CONTENTS

1.	Introduction	1
	1.1 Objective and scope of work.....	2
2.	Site description	3
	2.1 Site identification.....	3
	2.2 Site condition	4
	2.3 Surrounding land use	5
	2.4 Geology	5
3.	Site history	6
	3.1 Rahui Rd.....	6
	3.2 Kiwirail designation	6
4.	Potential for contamination	6
5.	Regulatory regime	7
	5.1 NES Soil	7
	5.2 Asbestos Regulations	7
6.	Site investigation works	8
	6.1 Works undertaken	8
	6.1.1 Rahui Road:.....	8
	6.1.2 KiwiRail Designation:.....	8
	6.1.3 Soil sampling procedure.....	9
7.	Subsurface conditions	10
8.	Analytical results	10
	8.1 Results	10
	8.1.1 Rahui Road area	11
	8.1.2 Kiwirail Designation	11
9.	Preliminary conceptual site model	11
10.	Implications of the presence of asbestos	13
	10.1 Regulatory implications.....	13
	10.2 Development implications.....	15

FIGURES

Figure 1 – Site location plan (Source: LINZ Data Service)	1
Figure 2 – Rahui Rd site area and layout prior to removal of the buildings (Source: Google Earth Pro 2017)	4
Figure 3 – Published geology of the Ōtaki area (source: Begg and Johnston).	5

TABLES

Table 1 – Site Identification	3
Table 2 – Observed soil profile at Rahui Rd	10
Table 3 – Observed soil profile of the main line (Kiwirail designation).....	10
Table 4 – Observed soil profile of the Ōtaki Sidings (Kiwirail designation).....	10
Table 5 – Preliminary CSM	12
Table 6 – Asbestos controls	16

APPENDICES

Appendix A: Figures 4 - 7
Appendix B: Site Photographs
Appendix C: Building Survey Data
Appendix D: Summary of Analytical Results
Appendix E: Laboratory Transcripts

1. Introduction

The Fletcher Construction Company Ltd (FCC) has been contracted by the New Zealand Transport Agency (NZTA) to deliver the Peka Peka to Ōtaki (PP2Ō) Expressway project under a Design and Construct contract. Tonkin & Taylor Ltd (T+T) has been engaged by FCC, to provide aspects of the project design, including asbestos ground investigations within the KiwiRail Designation and a former residential block of land at Rahui Road.

The PP2Ō Expressway forms part of the Wellington Northern Corridor, a series of road improvement projects along the State Highway 1 (SH1) network between Wellington Airport and Levin. The developments aim to reduce congestion, improve safety and support economic growth.

The expressway construction includes the following relating to this report:

- Realignment of the rail north of Ōtaki Railway Station, modifications to platform and the sidings to the south of the station. After realignment, the ballast is proposed to be removed from the former rail line, which will then remain within the designation; and
- A four lane expressway will be constructed across the Rahui Road block of land.

The location of the two areas of land investigated are presented below.

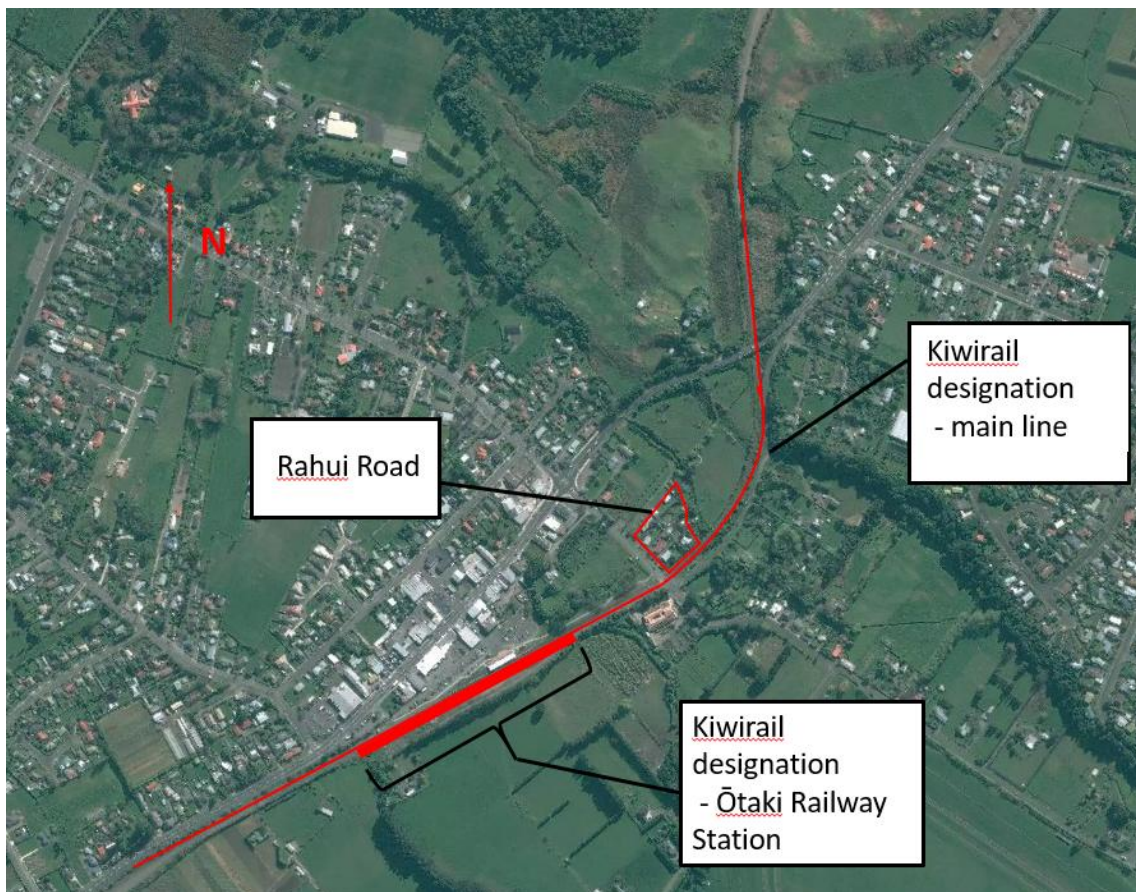

Figure 1 – Site location plan (Source: LINZ Data Service)

Figure 0. Site location plan (Source: LINZ Data Service)

This report has been prepared in general accordance with the requirements for a DSI (Detailed Site Investigation) referred to in the NES Soil regulations¹, and as outlined in the Ministry for Environment's (MfE) Contaminated Land Management Guidelines².

The persons undertaking, managing reviewing and certifying this investigation are suitably qualified and experienced practitioners as defined in the NES Soil.

1.1 Objective and scope of work

The investigation objectives are to:

Assess whether asbestos is present in the ground along the length of the KiwiRail Designation realignment, Ōtaki Sidings and the Rahui Road block of land;

Assess the precautions required during construction works in accordance with the Health and Safety at Work (Asbestos) Regulations (2016); and

- Assess the precautions required to protect the public and workers in the future.
- The impact of contaminants other than asbestos has been addressed by Beca in a separate report³.
- The scope of work for this investigation comprised:
 - Review of historic desk study reports produced by URS⁴ and Beca⁵;
 - Site inspection across the investigation areas;
 - Soil sampling for asbestos (See Figures 4, 5, 6 and 7 in Appendix A for locations):
 - Rahui Road:
 - § 26 shallow test pits (hand and machine dug).
 - KiwiRail Designation:
 - § Main line
 - 19 mechanical auger holes
 - 21 surface samples
 - § Ōtaki Railway Station sidings:
 - 10 machine dug test pits,
- Laboratory analysis of 81 samples for the presence of asbestos (quantitative) and seven fragments of boarding for presence/absence. Testing was also scheduled for other contaminants by Beca, the results of which are reported separately; and
- Production of this report.

¹ Resource Management (National Environmental Standard for Assessing and Managing Contaminants in Soil to Protect Human Health) Regulations 2011.

² Ministry for the Environment, updated 2011, Contaminated land management guidelines No. 1: *Reporting on Contaminated Sites in New Zealand*.

³ Beca (2017) Detailed Site Investigation (Contamination), Peka Peka to Otaki – Technical Report 4.

⁴ Final Report: Peka Peka to Ōtaki – Phase 1 Contaminated Land Assessment, URS, February 2013.

⁵ Rahui Housing Area, Preliminary Site Information memorandum, Beca, November 2017.

This report documents our findings and comments on controls for identified asbestos in soil, in the context of the proposed works.

2. Site description

2.1 Site identification

The site comprises two main areas. The first is an area of about 10,000 m² of land on the north side of Rahui Rd, Ōtaki between State Highway 1 and the railway corridor. Some vacant residential buildings remain on this area of land as well as the remains of residential buildings that have previously been demolished.

The realignment of the Kiwirail designation runs along the rail corridor, extending about 1,100 m to the north east and about 700 metres to the south west of the Ōtaki railway station as shown on Figure 2.

The site is identified further in Table 1

Table 1 – Site Identification

Street address	Rahui Rd: 30-40 Rahui Rd, Ōtaki Kiwirail Designation: Not applicable
Legal description	Rahui Rd: <ul style="list-style-type: none"> • Lot 2 DP 75842 (WN42C/515) • Lot 3 DP 23328 (WN15C/99) • Lot 4 DP 23328 (WN15C/100) • Lot 5 DP 23328 (WN15C/101) • Lot 6 DP 23328 (WN15C/102) • Lot 7 DP 23328 (WN15C/103) • Lot 8 DP 23328 (WN15C/104) • Lot 2 DP 83837 (WN50D/968) • Lot 1 83837 (WN50D/967) • Part Awahohonu A31 Block (WN50D/967) KiwiRail Designation (From north to south): <ul style="list-style-type: none"> • Part Pukehou 5K Block (WN74/131) • Awahohonu A1 Block (WN81/25) • Matitikura Block (WN48/159) • Part Te Awaroa 12A Block (WN55D/456) • Totaranui Section No 11F Block (WN77/162) • Part Lot 1 DP 16503 (WN11D/1161, WN1200/35)
Site area	Rahui Rd: 10,000 m ² Kiwirail Designation: 1,800 m in length and approximately 10 m wide.
Zoning ⁶	Rahui Rd: Residential Kiwirail Designation: Rural

⁶ Kāpiti Coast District Council District Plan Map - Districtwide and Urban Plan Zones and Features Map 3

2.2 Site condition

A contaminated land specialist completed a site walkover inspection of the Kiwirail designation on 21 September 2017 and at the Rahui Rd site on 27 September 2017. Relevant observations made at the time of the inspections are summarised below. Key site features are shown on Figure 2 and selected photographs are included in Appendix B (Site Photographs).



Figure 2 - Rahui Rd site area and layout prior to removal of the buildings (Source: Google Earth Pro 2017)

The Rahui Road section of the property currently contains vacant residential buildings and the remains of previously demolished buildings. The buildings are constructed of wood, brick, metal, corrugated plastic, aluminium composite material and fibrolite with concrete slabbing. There is a driveway running along the western boundary of the site. A stream runs along the north eastern boundary flowing in a north westerly direction towards the coast. The site is predominantly covered with topsoil and vegetation. Closer inspection of the soil revealed fragments of metal, ceramic and rock. Multiple stockpiles were present. The ground is generally flat lying.

The rail corridor of the Kiwirail designation is a 1.8 km section of the railway. Along the length of the Ōtaki Sidings was evidence of former buildings/structures, wood storage areas, a workshop building, gravel/ballast stockpiles, a goods shed, historic railway station building, car parking as well as a toilet block and service manholes.

2.3 Surrounding land use

The land uses in the area surrounding the site include:

Rahui Rd:

- North – Residential buildings, farmland;
- South – Rahui Road, The Ōtaki Milk Station;
- East – Rail corridor, County Road; and
- West – Residential buildings, farmland, petrol station, commercial buildings.

Kiwirail Designation:

The main trunk line passes through and is adjacent to:

- Farmland;
- Residential buildings;
- Commercial buildings;
- The Ōtaki Milk Station; and
- State Highway 1.

2.4 Geology

The Rahui Rd site and Kiwirail designation are located on an area of mostly flat, alluvial deposits which is described as ‘well-sorted floodplain gravels’.⁷

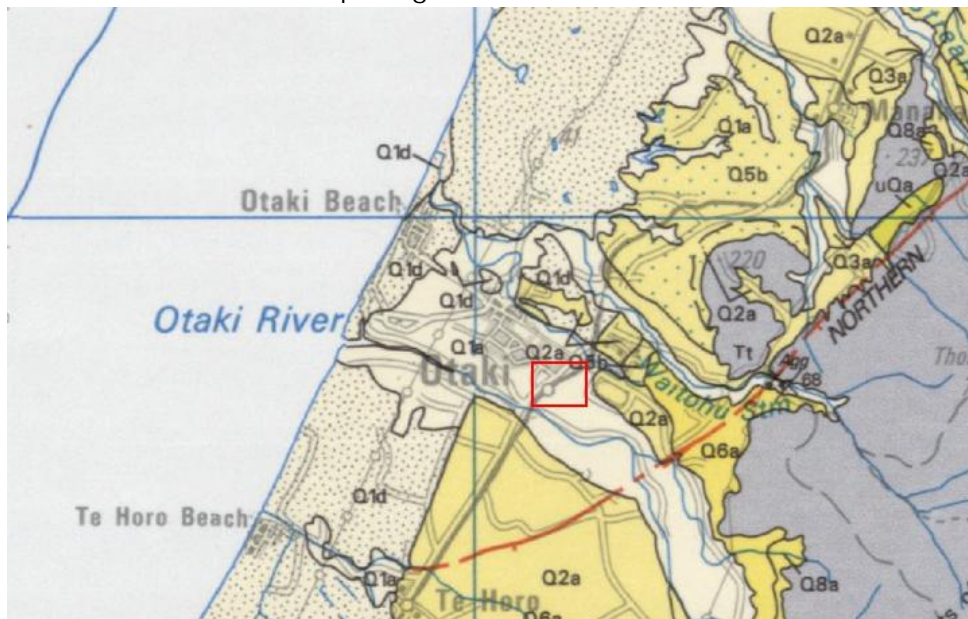

Figure 3 - Published geology of the Ōtaki area (source: Begg and Johnston⁸).

⁷ Begg, J.G. & Johnston, M.R. (compilers), 2000. Geology of the Wellington area. Institute of Geological and Nuclear Sciences Limited.

⁸ Begg, J.G. & Johnston, M.R. (compilers), 2000. Geology of the Wellington area. Institute of Geological and Nuclear Sciences Limited.

3. Site history

Based on our review of historic desk study reports produced by URS^{Error! Bookmark not defined.} and Beca^{Error! Bookmark not defined.}, the following site histories have been established in relation to asbestos in soil.

3.1 Rahui Rd

The site history indicates that this area was used for pastoral purposes up until at least the 1940s with some dwellings and sheds within the western third of the site (marked as "Historic Housing Area" on Figure 4 in Appendix A). By the early 1960s, the southern and eastern sections were converted to a market garden. By 2001, the site was converted wholly to residential land use, with nine dwellings and associated sheds and garages having been constructed. The site remained largely unchanged between 2001 and 2017.

Recent surveys identified asbestos within the fabric of some of the buildings on site. These buildings are indicated on Figure 4, based on data provided by Fletcher Construction Co. Ltd (enclosed in Appendix C).

3.2 Kiwirail designation

The main trunk line was constructed in the 1880s. There is no clear record of the history of the sidings area to the east of the station, however, in 1939 a signal adjusters' workshop was proposed, which may have been constructed in this area.

The land to the east of the main line appears to have been used primarily for horticulture and market garden use, although a holding area for stock was also located here. By 1971 there was a wood storage area and associated buildings located to the east of the main line.

4. Potential for contamination

Based on the desk study information, there is the potential for the presence of asbestos in the soils from the following:

- Construction, degradation and subsequent demolition of buildings containing asbestos (Rahui Road and Ōtaki Station Sidings); and
- Brake linings of trains (KiwiRail Designation and Ōtaki Station Sidings).

Sciences 1:250 000 geological map 10. 1 sheet + 64 p. Lower Hutt, New Zealand: Institute of Geological and Nuclear Sciences Limited.

5. Regulatory regime

The rules and associated assessment criteria relating to the control of asbestos in soils in the Ōtaki area are specified in the following documents:

- NES Soil; and
- Health and Safety at Work (Asbestos) Regulation (2016).

5.1 NES Soil

Activities covered under the NES Soil include soil disturbance. Soil disturbance activities are permitted subject to the following requirements:

1. Controls to minimise the exposure of humans to mobilised contaminants must be implemented and maintained until the soil is reinstated to an erosion-resistant state;
2. The soil must be reinstated to an erosion-resistant state within 1 month after the serving of the purpose for which the activity was done and the duration of the activity must be no longer than 2 months;
3. The volume of the disturbance of the soil on the piece of land must be no more than 25 m³ per 500 m² of HAIL area and a maximum of 5 m³ per 500 m² of soil may be taken away per year; and
4. Soil taken away in the course of the activity must be disposed of at a facility authorised to receive soil of that kind.

5.2 Asbestos Regulations

The Health and Safety at Work (Asbestos) Regulations (2016) were enacted on 1 April 2016. The regulations set out requirements for manufacturing, supplying, transporting, storing, removing, using, installing, handling, treating, disposing of, or disturbing asbestos or ACM. Worksafe New Zealand has prepared an Approved Code of Practice: Management and Removal of Asbestos (November 2016) which includes preliminary provisions related to asbestos in soils.

The key requirements of the regulations and ACoP are that works involving asbestos contaminated soils must be undertaken with appropriate asbestos controls in place and that contaminated soil removed from site must be taken to an approved disposal site. However, some details, such as the standards that will apply to asbestos-in-soils, are subject to guidance provided within the BRANZ New Zealand Guidelines for Assessing and Managing Asbestos in Soil (November 2017). The BRANZ Asbestos Guidelines define the level of oversight and controls (including personal protective equipment, decontamination, etc.) that are required to be implemented dependent on the concentration of asbestos fibres/fines or fragments that are present in the soils. In order to determine the licensing requirements required for the excavation and disposal of asbestos-contaminated soil, asbestos results will be assessed against the New Zealand Guidelines for Assessing and Managing Asbestos in Soil.

To assess the implications on health and safety from asbestos contamination, comparison has been made to the Asbestos Regulations (BRANZ asbestos in soil guidelines, 2017).

6. Site investigation works

6.1 Works undertaken

The following investigations were undertaken in November and December 2017.

6.1.1 Rahui Road:

2 machine dug test pits and 26 hand dug pits were excavated across the site, to target locations where buildings contained asbestos, as well as forming a general spread of sampling locations across the site. Sampling locations are shown on Figure 4.

The testing numbers are compliant with Appendix A of the Asbestos Guidelines (21 tests over a 9000m² area).

The target depth of TP 106 could not be met: shells were encountered at 0.4m depth and so the test pit was terminated to allow archaeological assessment.

6.1.2 KiwiRail Designation:

19 machine auger holes were drilled at 100m intervals along area of Main Line to be realigned. Ideally, test pits would have been dug to collect all samples at depth along the Main Line as these allow clearer visual observation of the strata encountered, larger samples and minimise the risk of cross-contamination. However, machine pits would have risked destabilising the rail line and so a mechanical auger was used instead. A second round of testing was undertaken in the vicinity of two locations where asbestos was identified (A11 and A17). Additional surface samples were taken around these locations to assess the extent of the asbestos contamination in these areas.

10 machine test pits were dug in the Ōtaki Sidings area, targeted on former buildings.

The siteworks were undertaken before the Asbestos Guidelines were published and provide less samples than indicated by Appendix A of the Asbestos Guidelines. However, along the Main Line, the identified source of asbestos is engine braking, which would have occurred over a significant distance. Therefore 100m intervals would be appropriate for characterising asbestos contamination of the ballast. At Ōtaki Station, 12 samples were taken over an approximately 250m x 20m area, which is one less than the thirteen samples indicated by the guidelines, however, as the sampling locations were targeted on the former buildings (i.e. the source of contamination), the sampling is likely to provide a conservative indication of the presence of asbestos.

Sampling locations are shown on Figures 5, 6 and 7. Test pit logs are provided in the Beca investigation report [Error! Bookmark not defined.](#)

6.1.3 Soil sampling procedure

Soil sampling was undertaken in general accordance with the requirements of the NES Soil and CLMG No. 5⁹. Soil samples were collected according to the following procedure:

- Freshly gloved hands were used to collect the discrete soil samples directly from the auger holes and excavator pits;
- 10 l soil samples were obtained from machine and hand dug test pits, as well as at the surface of the machine auger holes. 500 ml samples were obtained from the machine auger holes;
- Samples were placed immediately into laboratory supplied sample containers.
- Sampling equipment was decontaminated between sample locations using clean water and Decon 90 (a phosphate-free detergent) rinses; and
- Samples were shipped to IANZ accredited Precise Consulting Laboratory under chain of custody documentation for quantitative analysis.

⁹ Ministry for the Environment, 2011: Contaminated Land Management Guideline No.5 – Site Investigation and Analysis of Soils.

7. Subsurface conditions

The soils encountered during the site works were generally consistent with the anticipated geology and are summarised in Table 2 – Observed soil profile at Rahui Rd, Table 3 and Table 4 below.

Table 2 – Observed soil profile at Rahui Rd

Depth below ground level to top of layer (m)	Unit thickness (m)	Description
0-0.1	0.1	Topsoil
0.1-1.2	0.3	Silt with minor clay and sand
1.2- >1.6	0.4	Gravel

Table 3 - Observed soil profile of the main line (Kiwirail designation)

Depth below ground level to top of layer (m)	Unit thickness (m)	Description
0.0-0.15	0.15	Railway line
0.15-1.0	0.45	Rail ballast
1.0->1.8	0.4	Sandy gravelly clay

Table 4 - Observed soil profile of the Ōtaki Sidings (Kiwirail designation)

Depth below ground level to top of layer (m)	Unit thickness (m)	Description
0-0.1	0.01	Topsoil
0.01 – 0.4	0.3	Sandy gravel
0.4-0.9	0.5	Silt with clay
0.9-1.5	0.6	Sandy silt

8. Analytical results

8.1 Results

Analytical results are summarised in Appendix D, and full laboratory transcripts are also provided in Appendix E.

8.1.1 Rahui Road area

Of the twenty-one soil samples and seven fragments of boarding tested, five of the samples tested positive for asbestos: two boarding fragments and three soil samples. The soil samples and one of the boarding fragments were within the eastern third of the site and the other boarding fragment was close to this area. On this basis, asbestos in soil is indicated to be limited to the eastern third of the site (labelled as the "Historic Housing Area" on Figure 4).

Two of the positive soil samples (TP 106 at surface and at 0.2m, TP 205 at 0.1m) comprised fragments of cement boarding (chrysotile asbestos), and the third comprised free chrysotile fibres. Only one soil sample gave an asbestos concentration greater than 0.001% (0.003% in TP 106 at the surface).

8.1.2 Kiwirail Designation

Asbestos was only identified along a 600m section of the Main Line, centred on Ōtaki Station and also within the Ōtaki Sidings:

- Main Line – Concentrations of free chrysotile fibres (less than 0.001%) at the surface and within the railway ballast between sampling locations A11 and A17. This asbestos is probably related to the braking of trains on approach to the station. A single hotspot of free chrysotile (and amosite) fibres and fibrous material (up to 0.035%) was identified within an approximately 10m section of the Main Line between locations A11.04 and A11.11; and
- Ōtaki Sidings – Concentrations of free chrysotile fibres (less than 0.001%) within the ballast and within the fill (in TP 116 at 0.3m and TP122 at 0.9m). This asbestos is probably related to related to former buildings (possibly with a contribution from braking).

9. Preliminary conceptual site model

A conceptual site model (CSM) as defined by MfE in the contaminated land management guidelines¹⁰, sets out known and potential sources of contamination, potential exposure pathways, and potential receptors. For there to be an effect from the proposed activity there has to be a contamination source and a mechanism (pathway) for contamination to affect human health or the environment (receptor).

A preliminary conceptual site model has been developed for the proposed activity, which takes into account the available information about the site, and our understanding of the potential effects on human health and the environment. The preliminary CSM is presented below.

¹⁰ Ministry for the Environment, updated 2011, *Contaminated Land Management Guidelines No. 5 Site Investigation and Analysis of Soils*

Table 5 - Preliminary CSM

Source	Pathway	Receptor	Pathway Assessment
Rahui Road: Asbestos in soil	Inhalation of dust	Excavation/Maintenance workers	Potentially complete during soil disturbance works
	Inhalation of dust	Future site users	Potentially complete as site will not be beneath the expressway
Main Line and Ōtaki Sidings: Asbestos in soil	Inhalation of dust	Excavation/Maintenance workers	Potentially complete during soil disturbance works
	Inhalation of dust	Future site users	Potentially complete

The preliminary CSM indicates that appropriate controls should be implemented during the excavation works, future maintenance works, and to protect end-users. In addition, controls will be required in areas where excess soils containing asbestos are permanently placed within the works (e.g. as noise or landscaping bunds).

10. Implications of the presence of asbestos

The results of the desk study assessment and asbestos soil testing indicate that asbestos in soil presents no practical constraint to the proposed construction works, provided adequate controls are put in place.

10.1 Summary of identified asbestos contamination

Asbestos has been identified as present within the following areas addressed in this report:

- Rahui Road (western area, as shown as the “Historic Housing Area” on Figure 4);
 - Location - Asbestos has been identified across this area at the surface and within the fill.
 - Depth of affected soils - Two test pits were dug at the south-western end of the Historic Housing Area (TP 106 and TP 107): fill was encountered to 0.2m in TP 107 and to at least 0.4m in TP 106 (shells were encountered at 0.4m depth in TP 106 and so the excavation was terminated). Further test pitting across the Historic Housing Area would be required to accurately assess the depth of fill.
 - Concentration - Asbestos fibres (20 samples less than 0.001%, with a single result of 0.003%) reported across this area at the surface and within the fill. Five samples of asbestos cement boarding (ACM) identified (ie comprising significantly less than 0.01% of the fill).
- Main Line (between locations A11.03 and A17);
 - Location –
 - o Within ballast along a 600m length of main line (approximately 300m either side of Ōtaki Station, between sampling locations A11.11 and A17).
 - o Hotspot within ballast approximately 300m north-east of Ōtaki Station (between locations A11.04 and A11.11)
 - Depth of affected soils - Drilling of the ballast could only be undertaken at the edges of the rail line, due to KiwiRail constraints; at the edges the ballast was encountered to between 0.5m and 1.0m depth.
 - Concentration –
 - o Along 600m length of main line - Asbestos fibres (less than 0.001%) reported within the ballast. No ACM identified.
 - o Hotspot – Asbestos fibres (up to 0.035%) reported within the ballast. No ACM identified.
- Ōtaki Sidings.
 - Location - Asbestos was identified within the fill at the sidings.
 - Depth of affected soils – The fill was encountered to between 0.5m and 1.0m depth in the test pits.
 - Concentration - Asbestos fibres (less than 0.001%) reported within the ballast and fill at the sidings. No ACM identified.

10.2 Regulatory implications

The NES Soil¹¹ and the Asbestos regulations apply where asbestos has been identified in the soil.

The proposed earthworks are very unlikely to meet the NES Soil permitted activity requirements (as detailed in Section 5.1) and so consent is likely to be required from Kapiti Coast District Council under the provisions of the NES Soil.

In accordance with Regulations 9(1) and 10(2) of the NES Soil, the status of a consent application for soil disturbance depends on whether the results of soil testing are greater or less than the applicable land use standard:

- Less than the applicable land use standard – Controlled Activity
- Greater than the applicable land use standard – Restricted Discretionary Activity.

Soil contaminant standards for asbestos are provided within the New Zealand Guidelines for Assessing and Managing Asbestos in Soil (BRANZ, 2017). For all land uses, the applicable standard for asbestos fibres in soil is 0.001% and greater than 0.01% for ACM.

From the investigation results (summarised in Section 10.1), the consent status for the areas where asbestos in soil has been identified are as follows:

- Rahui Road – Only one of 21 soil samples exceeded the 0.001% standard and this exceedance was marginal (0.003%). Therefore, we conclude that average exposure of people to the asbestos in the fill would be equivalent to exposure from soil containing less than 0.001% asbestos fibres (ie below the human health standard defined by the New Zealand Guidelines for Assessing and Managing Asbestos in Soil). On this basis the consent status would be Controlled.
- KiwiRail Designation (Main Line)
 - 600m length of main line – Controlled Activity
 - Hotspot – Restricted Discretionary Activity
- Ōtaki Sidings – Controlled Activity.

This site investigation report will need to be provided to KCDC as part of the consent application, along with a Site Management Plan.

Guidance on addressing the requirements of the Asbestos Regulations are provided in Section 10.2 below.

¹¹ HAIL Category I: Land that has been subject to the accidental release of a hazardous substance in sufficient quantity to cause a risk to human health

As described at the bottom of Table 6 below, Fletcher Construction Company Ltd propose to remove asbestos contaminated soils/ballast to landfill or place them in land that will remain within the designation on a long-term basis. The ballast from the hotspot area (between locations A11.04 and A11.11) is proposed to be capped and maintained long-term, if not removed to landfill. This will result in exposure of end-users from the identified asbestos in the soils/ballast being less than the applicable health standard and on this basis, we conclude that the ongoing effects will be less than minor.

10.3 Development implications

The BRANZ Asbestos Guidelines indicate that the following precautions are required during construction works. It would be prudent to confirm these precautions with Worksafe prior to incorporating them into the existing Site Management Plan¹².

¹² Bulk Earthworks Contaminated Land Management Plan – Peka Peka to Otaki Project, June 2017.

Table 6 - Asbestos controls

Control		Fill at Rahui Road (western third of site, shown as "Historic Housing Area" on Figure 4)	Main line ballast (between sample locations A11 and A17)	Ōtaki Sidings ballast and fill	Main line ballast hotspot (between sample locations A11 and 11.03)
Class of asbestos removal works		Unlicensed Asbestos work			Class B
Supervision		Competent person (as defined in the Asbestos Regulations)			Class B Removalist
Asbestos Control Plan		Not required			Required
PPE		No asbestos-specific PPE required			Disposable overalls Nitrile Gloves Overshoes Half face P3 mask
Wetting of soils		Ensure that the soils are wet, so that no dust is created			Water suppression with use of polymer
Air Monitoring		Not required, but may be prudent to undertake some monitoring to demonstrate that no significant asbestos in air was generated.			Not required, but recommended by guidelines
Transportation	On site	Covered trucks			Covered trucks with soils well wetted down
	Off site	Cover trucks transporting the soil, wrapping should not be required unless the receiving site has specific wrapping requirements. Disposal as asbestos waste.			Lined and covered trucks
Decontamination		Footwash and PPE collection area.			Basic decontamination tent and footwash
		Wash (low pressure) soil from trucks and vehicles before leaving site (or crossing over into the uncontaminated area) – to be checked by visual inspection by competent person on completion.			
Clearance and validation		Visual assessment of vehicles before demobilisation from site by a competent person			
		No special testing required			Swab samples to be taken from vehicles

Control	Fill at Rahui Road (western third of site, shown as "Historic Housing Area" on Figure 4)	Main line ballast (between sample locations A11 and A17)	Ōtaki Sidings ballast and fill	Main line ballast hotspot (between sample locations A11 and 11.03)
Finishing surfacing/cover	No special finishing/cover requirements. However, it would be prudent to keep these soils separate from uncontaminated soils.			Capping with hardstanding, or geotextile beneath at least 0.5m of soft cap.
Ongoing management	No special management requirements.			Long term monitoring and maintenance to ensure the integrity of the capping.
	In accordance with the Asbestos Regulations the location of <u>all</u> soils containing asbestos will need to be recorded in an asbestos management plan.			

The nature and continuity of subsoil away from the sampling locations are inferred and it must be appreciated that actual conditions could vary from the assumed model. Therefore, workers, and particularly the Competent Person supervising, should be aware that unexpected contamination could be encountered during the works. The Competent Person should be able to identify potential asbestos if unexpected materials are encountered. If odorous, unusually coloured, or potential asbestos materials are encountered during the works, then please call us immediately for advice.

Appendix A

FIGURES 4 TO 7



LEGEND

- Site Boundary
- Historic Housing Area (Construction Prior to 1971)
- Building – no Asbestos
- Building – Asbestos Identified
- Building – Asbestos Test Awaited
- 214N5 Sample Location
- TP107 Test Pit Location

Note:
 1. Aerial photo sourced from Linz Data Service <<https://data.linz.govt.nz/data/>> , licensed by LINZ for re-use under the Creative Commons Attribution 3.0 New Zealand licence (CC BY 3.0 NZ).

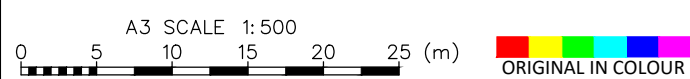

NZ TRANSPORT AGENCY
WAKA KOTAHI

Peka Peka to Ōtaki Expressway

DRAWN	JELO	Feb. 18
DRAFTING CHECKED		
APPROVED		
CADFILE : \\85985.007-F2.dwg		
SCALES (AT A3 SIZE)		
AS SHOWN		
PROJECT No.	85985.007	

NZ TRANSPORT AGENCY

PP20 – SITE INVESTIGATION

RAHUI ROAD, OTAKI

Soil Sampling Location

FIG. No.	Figure 4	REV.	0
----------	----------	------	---

\\group\corporate\Wellington\TT Projects\85985\85985.007\01001 CAD\WorkingMaterial\09 CAD\Figures\85985.007-F2.dwg, F2, 20/02/2018 9:02:20 AM, jelo



LEGEND	
	Hand auger
	Test pit

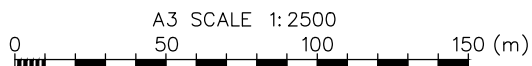

NOTE:
 1. Aerial photo sourced from Linz Data Service Wellington 0.3m Rural Aerial Photos (2012–2013), licensed by LINZ for re-use under the Creative Commons Attribution 3.0 New Zealand licence (CC BY 3.0 NZ)

DRAWN	IARA Feb. 18
DRAFTING CHECKED	
APPROVED	
CADFILE :	85985.0070-F05_07.dwg
SCALES (AT A3 SIZE)	
1:2500	
PROJECT No.	85985.0070

NZ TRANSPORT AGENCY
 PP20 – DETAILED DESIGN
 KIWRIL DESIGNATION – OTAKI
 Geotechnical Investigation

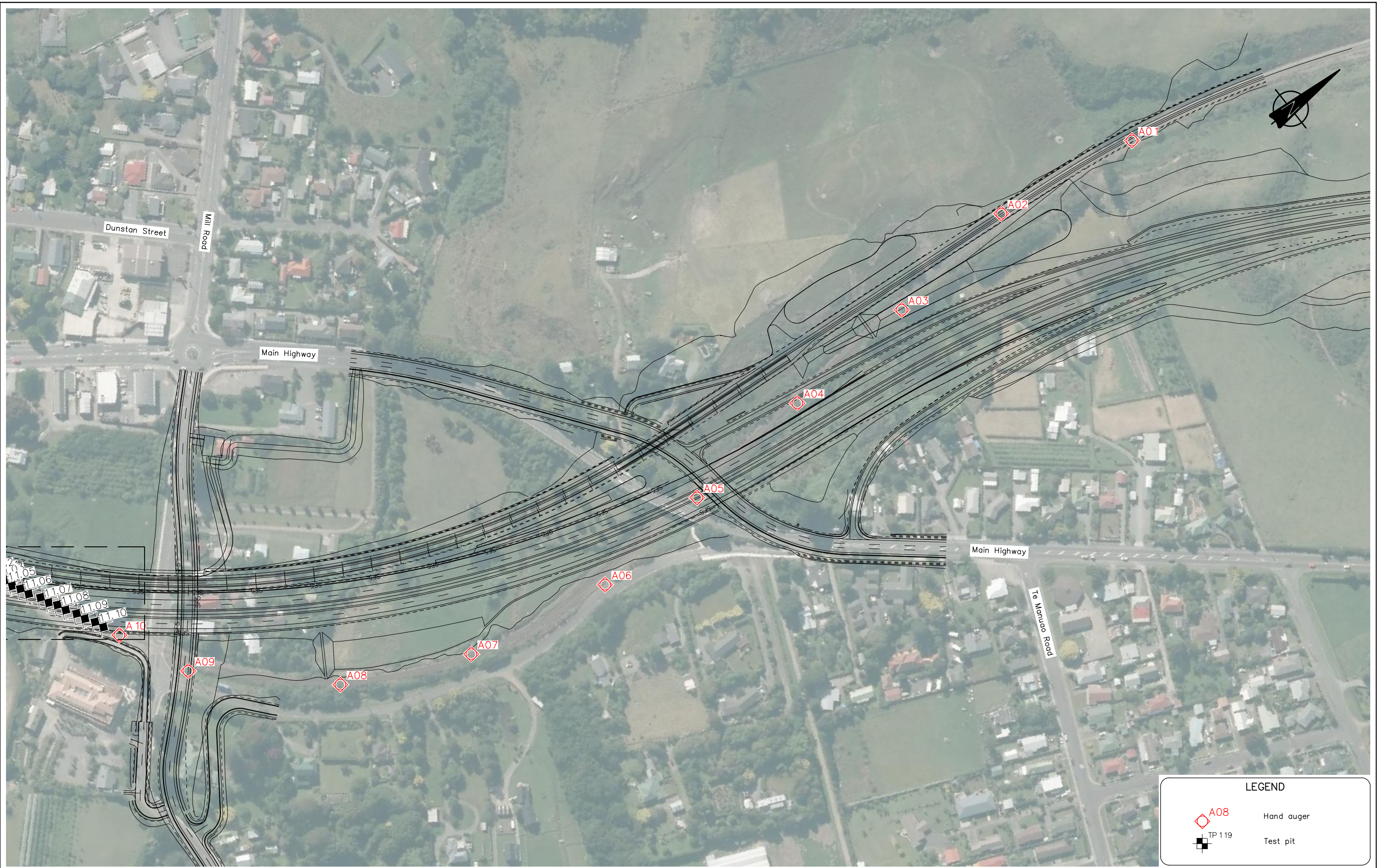

LEGEND

 A08 Hand auger

 TP 119 Test pit



NOTE:
1. Aerial photo sourced from Linz Data Service Wellington 0.3m Rural Aerial Photos (2012–2013), licensed by LINZ for re-use under the Creative Commons Attribution 3.0 New Zealand licence (CC BY 3.0 NZ)

DRAWN	IARA	Feb. 18
DRAFTING CHECKED		
APPROVED		
CADFILE : 85985.0070-F05_07.dwg		
SCALES (AT A3 SIZE)		
1:2500		
PROJECT No.	85985.0070	

NZ TRANSPORT AGENCY
PP20 – DETAILED DESIGN
KIWIRAIL DESIGNATION – OTAKI
Geotechnical Investigations

FIG. No. **Figure 6** REV. **0**

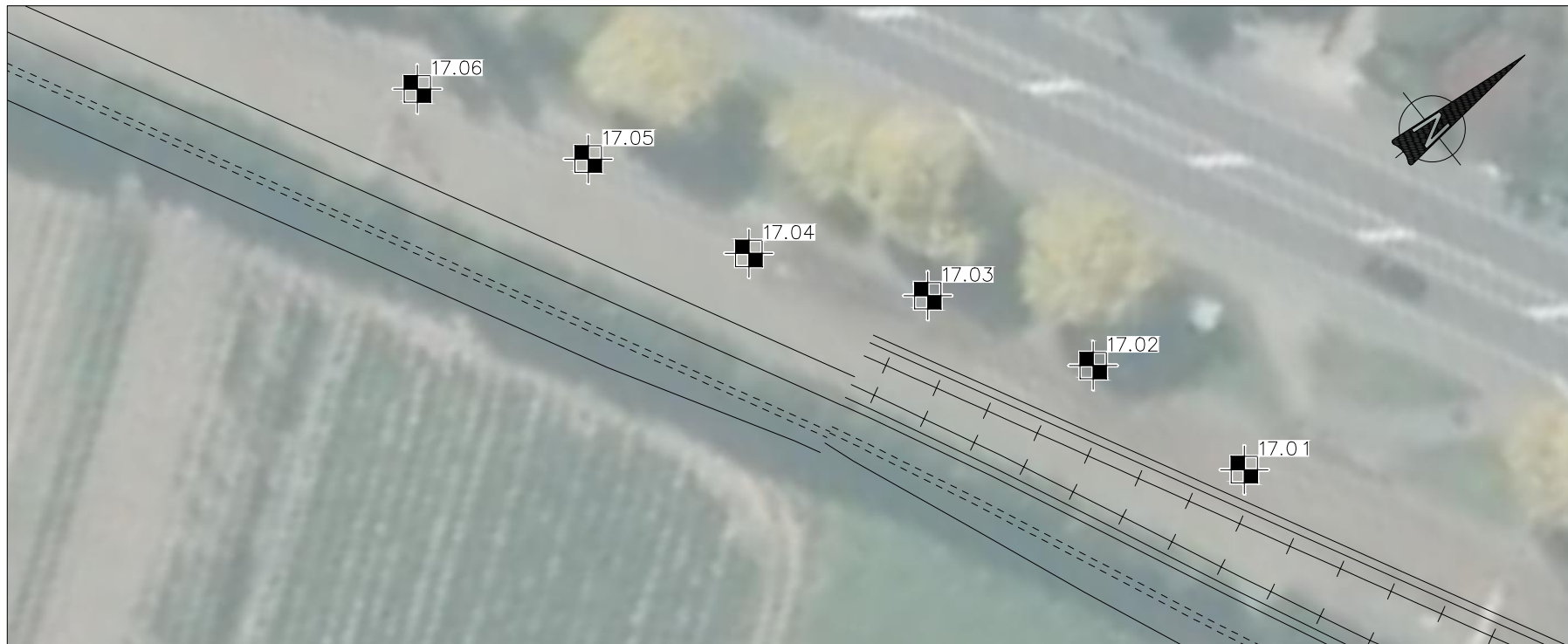

DETAIL A
SCALE 1:500
F05

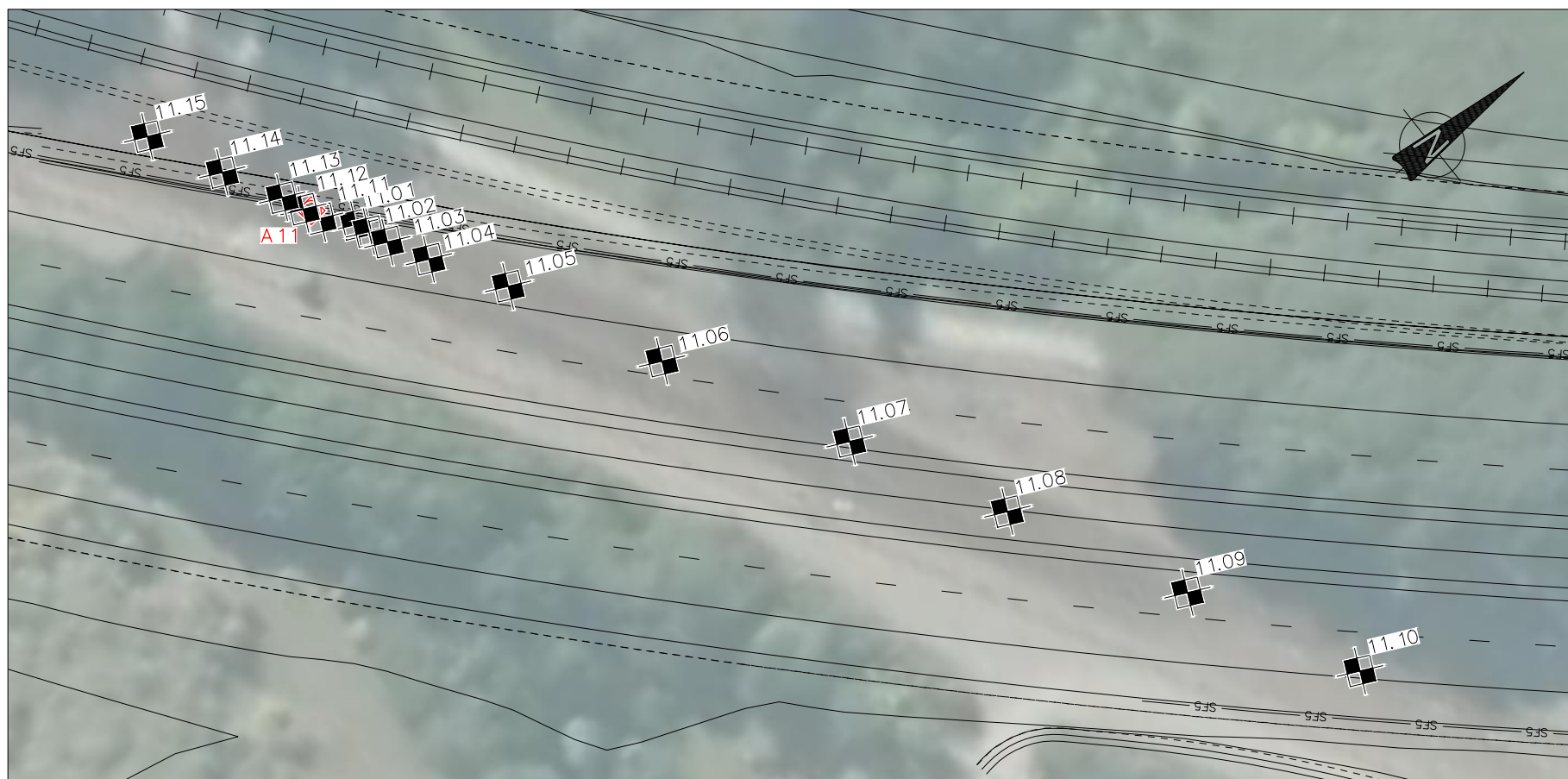

DETAIL B
SCALE 1:500
F05

LEGEND	
	A08 Hand auger
	TP 119 Test pit

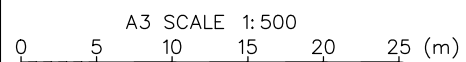

NOTE:
1. Aerial photo sourced from Linz Data Service Wellington 0.3m Rural Aerial Photos (2012–2013), licensed by LINZ for re-use under the Creative Commons Attribution 3.0 New Zealand licence (CC BY 3.0 NZ)

 NZ TRANSPORT AGENCY WAKA KOTAHĪ Peka Peka to Ōtaki Expressway	DRAWN IARA Feb. 18 DRAFTING CHECKED APPROVED
	CADFILE : \\85985.0070-F05_07.dwg SCALES (AT A3 SIZE) 1: 500 PROJECT No. 85985.0070

NZ TRANSPORT AGENCY
 PP20 – DETAILED DESIGN
 KIWIRAIL DESIGNATION – OTAKI
 Geotechnical Investigations

FIG. No. Figure 7

REV. 0

Appendix B

SITE PHOTOGRAPHS



The buildings are constructed of wood, brick, metal, corrugated plastic, aluminium composite material and fibrolite with concrete slabbing (photos taken: September 2017)



Vacant residential buildings with surrounding topsoil and vegetation (photos taken: November 2017)



Driveway running along the western boundary of the site, taken from the western corner, facing north east (photo taken: September 2017)



Vacant residential building and stockpiled remains of previously demolished buildings, taken from the western corner, facing south east (photo taken: September 2017)

Appendix C

BUILDING SURVEY DATA

Jane Rendall

From: Damien Moloney (Construction Infrastructure) <DamienM@fcc.co.nz>
Sent: Tuesday, 14 November 2017 1:50 PM
To: Chris Hillman
Cc: Richard Rakovics (Construction Infrastructure); Steve Findlay (Construction Infrastructure)
Subject: Rahui Road Markup
Attachments: 270917 CHM SitePlan_labels ACMDetectspdf.pdf; FW: 34 Rahui Road

Hi Chris,

On the basis of yesterday's discussion, please find attached mark up with comments in relation to the properties that are located in Rahui Road.

In addition to this please find one of the reports for one of the properties, Rahui Road no 36. (email subject is incorrect)

On the basis of this please advise what testing you require in this area? Also can you advise how soon one of your engineers can come to site as we would like to get these works underway ASAP.

Regards

Damien Moloney

Project Engineer | Infrastructure

The Fletcher Construction Company Ltd

2 Ake Ake Place, Otaki, 5512.

Ph: + **Mob:** +64 27 405 7261 **Email:** damienm@fcc.co.nz

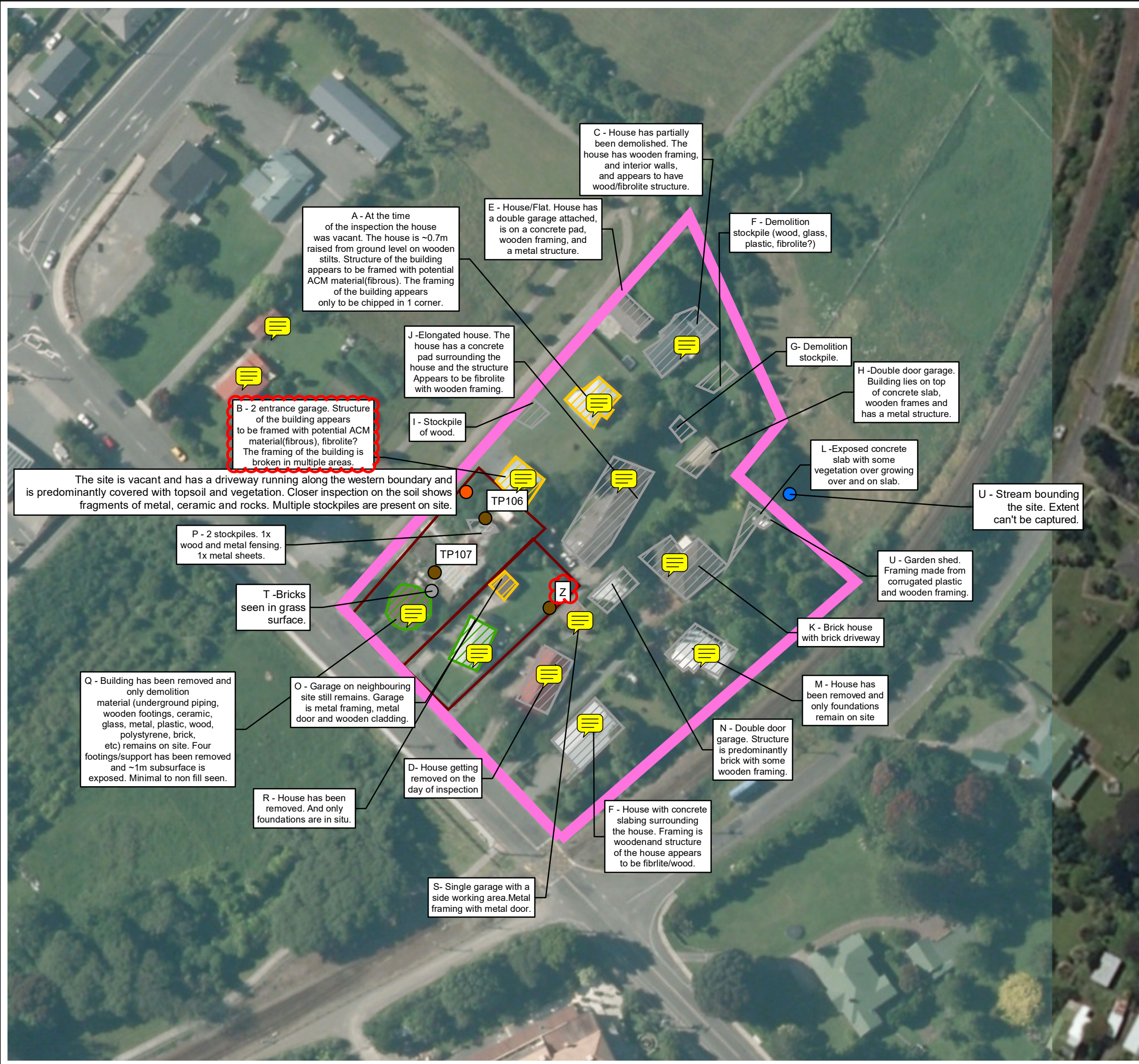

LEGEND

 Positive asbestos fibres

A3 SCALE: 1:1,000

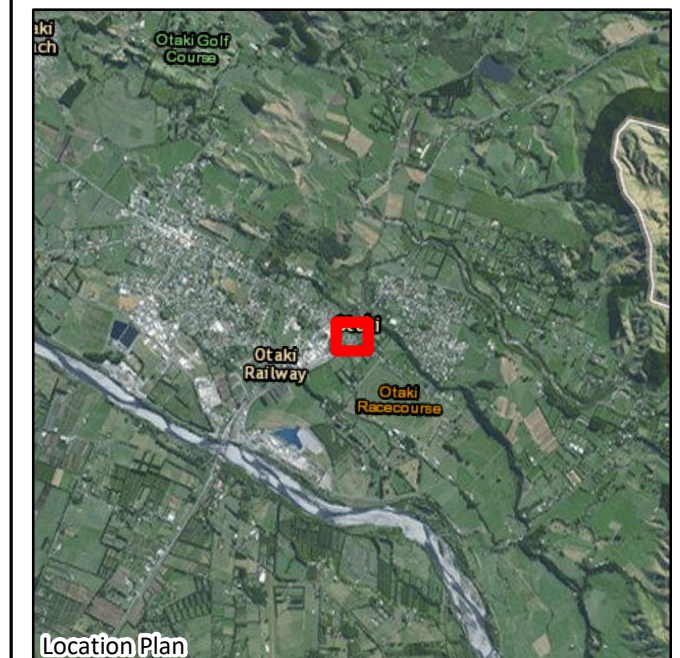
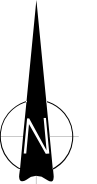
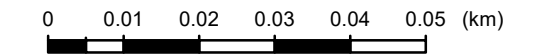

Notes:

Aerial photo sourced from the LINZ Data Service [https://data.linz.govt.nz/layer/Auckland-0.125m-Urban-Aerial-photos-\(2010-2011\)](https://data.linz.govt.nz/layer/Auckland-0.125m-Urban-Aerial-photos-(2010-2011)) and licensed by Auckland Council for re-use

DRAWN	CHM	Sep.17
CHECKED		
APPROVED		
ARCFILE 270917.CHM.SitePlan_labels.mxd		
SCALE (AT A3 SIZE)		1:1,000
PROJECT No.	85985.007	



Tonkin+Taylor
105 Carlton Gore Rd, Newmarket, Auckland
www.tonkintaylor.co.nz

BECA LTD.
PP20 - SITE INSPECTION
RAHUI ROAD, OTAKI
27/09/2017

Figure 1. Site Walkover

Jane Rendall

From: Mark Anderson (Higgins) (EXTERNAL: Higgins) <M.Anderson@higgins.co.nz>
Sent: Tuesday, 14 November 2017 11:20 AM
To: Damien Moloney (Construction Infrastructure)
Subject: FW: 34 Rahui Road
Attachments: 36 Rahui Road Sample Results.pdf; 36 Rahui Road, Otaki Asbestos Assessment Survey & Analysis.pdf; 36 Rahui Road, Otaki Asbestos Register.pdf

Mark Anderson
Project Engineer (Drainage/Utilities)

Higgins *showing the way*

Unit 2 & 3, 2 Ake Ake Place, Otaki |
Mob: +64 27 4111005 **Email:** m.anderson@higgins.co.nz
Site Office: PP20 Otaki Project Office, Unit 2 & 3, 2 Ake Ake Place, Otaki |

From: Ian Butcher [<mailto:ian@centraldemolition.co.nz>]
Sent: Tuesday, 14 November 2017 8:18 a.m.
To: Nick Wall
Cc: Mark Anderson
Subject: FW: 34 Rahui Road

Please find attached survey results for 36 Rahui Road.

Regards,
Ian Butcher.

Ian Butcher
PO Box 1355
Palmerston North
ian@centraldemolition.co.nz
0800 344 421
021 434 641



From: Ali Lind [<mailto:ali.lind@aisl.co.nz>]
Sent: Monday, 13 November 2017 9:12 AM
To: Ian Butcher <ian@centraldemolition.co.nz>
Subject: 34 Rahui Road

Hey Ian

Attached is info regarding 34 Rahui Road, Otaki



BULK SAMPLE IDENTIFICATION CERTIFICATE

Job Number: 17-042162 Certificate Issue Date: 09-Nov-17

Date Samples Received: 09/11/2017
No of Samples: 12

Sampled By: Client
Obtained: Submitted by client

Date Analysed: 09/11/2017
Analyst: Cyrus Chao
Method: AS 4964 (2004) - Method for the Qualitative Identification of Asbestos in Bulk Samples

Client: Asbestos Inspection Services Limited
Client Address: 71 Thatcher Street, Whanganui 4501

Client Ref No: -
Contact: Bruce
Site Address: 36 Rahui Road, Otaki

We examined the following sample(s) using Low Powered Stereomicroscopy followed by 'Polarised Light Microscopy' including Dispersion Staining Techniques. The result(s) in this certificate relate(s) to the sample(s) as received.

GLOSSARY

CHRYSTOLITE (WHITE ASBESTOS) - CROCIDOLITE (BLUE ASBESTOS) - AMOSITE (BROWN ASBESTOS) - TREMOLITE, ANTHOPHYLLITE & ACTINOLITE (LESS COMMON ASBESTOS FIBRE TYPES) - SMF (SYNTHETIC MINERAL FIBRE)

Where non-asbestos fibres and the product type are listed, this is to help in the interpretation of results and are the opinion of the analyst only. Where the sampling is not conducted by Dowdell & Associates Ltd, the information indicated is that supplied by the client. Dowdell & Associates Ltd cannot be held responsible for sampling errors where the sample is taken by others. In analyzing non-homogeneous Bulk Materials and Soils for the presence of Asbestos, inherent difficulties arise while using the 'standard' Stereomicroscopic / Polarised Light Microscope method in determining differences between those samples considered as containing 'No Asbestos', those containing 'Trace' asbestos and those samples considered as having asbestos present but in very low concentrations. 'Trace' Asbestos is defined in the 'AS 4964 (2004) – Method for the Qualitative Identification of Asbestos in Bulk Materials', which is the most current of methods available for this type of analysis. Dowdell & Associates Ltd, while making every effort to minimise such difficulties, takes no responsibility for the misidentification of such samples and the subsequent actions taken by the client as a result of such analyses. A in-house subsampling method based on Western Australia guidelines is used for soil samples received above 150 grams.

NOTE: This report must not be altered, or reproduced except in full.



Analyst: 	Name: Cyrus Chao
--	------------------

Approved By: 	KTP: Adam Ngawati
--	-------------------

17-042162 Results

Laboratory Reference	Sample Ref / Description	Sample size as received	Sample Weight Analysed	Result	Comments
149847	1. Dwelling - Wall framing - Paper between brick work Paper	6g	As received	No Asbestos detected	Organic fibres present
149848	2. Dwelling - Electrical fuseboard Bitumen	5g	As received	No Asbestos detected	Organic fibres present
149849	3. Dwelling - Front door entry - Board	>100cm ²	As received	Chrysotile (White Asbestos)	n/a
149850	4. Dwelling - Front door entry - Outer wall cladding Fibre cement	>100cm ²	As received	Chrysotile (White Asbestos)	n/a
149851	5. Dwelling - Conservatory - Ceiling Board	>100cm ²	As received	Chrysotile (White Asbestos)	n/a
149852	6. Dwelling - Laundry - Vinyl backing	>100cm ²	As received	Chrysotile (White Asbestos)	n/a
149853	7. Dwelling - Laundry - Ceiling Textured Coating	4g	As received	No Asbestos detected	n/a
149854	8. Dwelling - En suite - Ceiling Textured Coating	4g	As received	No Asbestos detected	n/a
149855	9. Rear fence line - Board	>100cm ²	As received	No Asbestos detected	Organic fibres present
149856	10. Garage (South side) - Loose Debris	>100cm ²	As received	Chrysotile (White Asbestos)	n/a
149857	11. Garage (Internal) - Ceiling building Paper	>100cm ²	As received	No Asbestos detected	Organic fibres present
149858	12. Garage (Internal) - Electrical fuseboard Bitumen	8g	As received	No Asbestos detected	Organic fibres present

ASBESTOS ASSESSMENT SURVEY AND ANALYSIS

CLIENT INFORMATION

ORGANISATION'S (PCBU) NAME	MDC Ltd
ORGANISATION'S OFFICE ADDRESS	Feilding, Manawatu Region
SITE SPECIFIC SITE OF SURVEY	36 Rahui Road, Otaki
CONTACT PERSON	Ian Butcher
POSITION TITLE IN ORGANISATION	Owner/Operator
CONTACT NUMBER	M: 021 434 641
EMAIL ADDRESS	ian@centraldemolition.co.nz

Project Information



This survey shall be identified as building specific survey.

This survey is specifically to identify any asbestos containing material that may be associated with the property of 36 Rahui Road, Otaki

suspected areas shall be determined throughout this survey and analysis of laboratory findings.

Survey company's name: **ASBESTOS INSPECTION SERVICES LTD**

Office Address: **71 Thatcher Street, Castlecliff. Whanganui**

Email Address: bruce.wakefield@aisl.co.nz

Surveyors name: Bruce Wakefield

Phone number: 027 765 5123

Dates of Assessment: 7th November 2017

Duration: 4 Hours

Facility Type: Industrial Site Commercial Site Residential Site Rural Site
 Hospital Site Military Site Education Site Government Site

Assessment Purpose: Emergency Demolition Renovation Prohibition
 Relocation Fire Damage Contam Soil Investigation

Identification Key:

No ACM detected	Suspected of ACM (awaiting on sample result)	ACM clearly Identified without (sample being taken)	Reference to similar material sample (ACM) or (ACD) collected
-----------------	--	---	---

Location No:	Location Assessed	Material Type Identified	Select if suspect ACM was identified		Select if sample Was collected		Sample No Or enter Non-Asbestos	Condition of ACM or Insignificant material	Quantity m2 Or Quantity Not Required	ACM Friability (Actual condition) Yes = ACM is friable No = ACM is Non-friable Or select N/A
01	External: Roof Material	Clay Tiles	Yes <input type="checkbox"/>	No ✓	Yes <input type="checkbox"/>	No ✓	Non-Asbestos	Insignificant Material	Quantity Not Required	Yes No N/A <input type="checkbox"/> <input type="checkbox"/> ✓
02	External: Spouting System	PVC Material	Yes <input type="checkbox"/>	No ✓	Yes <input type="checkbox"/>	No ✓	Non-Asbestos	Insignificant Material	Quantity Not Required	Yes No N/A <input type="checkbox"/> <input type="checkbox"/> ✓
03	External: Down-pipes	PVC Material	Yes <input type="checkbox"/>	No ✓	Yes <input type="checkbox"/>	No ✓	Non-Asbestos	Insignificant Material	Quantity Not Required	Yes No N/A <input type="checkbox"/> <input type="checkbox"/> ✓
04	External: Wall Framing	Brick Material	Yes <input type="checkbox"/>	No ✓	Yes <input type="checkbox"/>	No ✓	Non-Asbestos	Insignificant Material	Quantity Not Required	Yes No N/A <input type="checkbox"/> <input type="checkbox"/> ✓
05	External: Wall Framing Paper	Suspect ACM Paper	Yes ✓	No <input type="checkbox"/>	Yes ✓	No <input type="checkbox"/>	001	Good Condition	100.0m2	Yes No N/A <input type="checkbox"/> ✓ <input type="checkbox"/>
06	External: Window Framing	Glass, Metal Product	Yes <input type="checkbox"/>	No ✓	Yes <input type="checkbox"/>	No ✓	Non-Asbestos	Insignificant Material	Quantity Not Required	Yes No N/A <input type="checkbox"/> <input type="checkbox"/> ✓
07	External: Fuse Board (Front Entry)	Suspect ACM Board	Yes ✓	No <input type="checkbox"/>	Yes ✓	No <input type="checkbox"/>	002	Good Condition	.500	Yes No N/A <input type="checkbox"/> ✓ <input type="checkbox"/>
08	External: Front Entry-Walls	Plaster, Timber	Yes <input type="checkbox"/>	No ✓	Yes <input type="checkbox"/>	No ✓	Non-Asbestos	Insignificant Material	Quantity Not Required	Yes No N/A <input type="checkbox"/> <input type="checkbox"/> ✓
09	External: Front Entry-Floor	Clay Tiles	Yes <input type="checkbox"/>	No ✓	Yes <input type="checkbox"/>	No ✓	Non-Asbestos	Insignificant Material	Quantity Not Required	Yes No N/A <input type="checkbox"/> <input type="checkbox"/> ✓
10	External: Front Entry-Ceiling	Suspect ACM Board	Yes ✓	No <input type="checkbox"/>	Yes ✓	No <input type="checkbox"/>	003	Partly Damaged	2.0m2	Yes No N/A <input type="checkbox"/> ✓ <input type="checkbox"/>
11	External: Front Entry-Outer Wall Cladding	Suspect ACM Board	Yes ✓	No <input type="checkbox"/>	Yes ✓	No <input type="checkbox"/>	004	Partly Damaged	8.0m2	Yes No N/A <input type="checkbox"/> ✓ <input type="checkbox"/>
12	External: Side Entry-Outer Wall Cladding	Suspect ACM Board	Yes ✓	No <input type="checkbox"/>	Yes <input type="checkbox"/>	No ✓	Refer to 004	Good Condition	4.0m2	Yes No N/A <input type="checkbox"/> ✓ <input type="checkbox"/>

Location No:	Location Assessed	Material Type Identified	Select if suspect ACM was identified		Select if sample Was collected		Sample No Or enter Non-Asbestos	Condition of ACM or Insignificant material	Quantity m2 Or Quantity Not Required	ACM Friability (Actual condition) Yes = ACM is friable No = ACM is Non-friable Or select N/A		
			Yes	No	Yes	No				Yes	No	Yes
13	External: Side Entry-Floor Material	Clay Tiles	<input type="checkbox"/>	<input checked="" type="checkbox"/>	<input type="checkbox"/>	<input checked="" type="checkbox"/>	Non-Asbestos	Insignificant Material	Quantity Not Required	<input type="checkbox"/>	<input type="checkbox"/>	<input checked="" type="checkbox"/>
14	External: Side Entry-Ceiling Material	Suspect ACM Board	<input checked="" type="checkbox"/>	<input type="checkbox"/>	<input type="checkbox"/>	<input checked="" type="checkbox"/>	Refer to 003	Good Condition	2.0m2	<input type="checkbox"/>	<input checked="" type="checkbox"/>	<input type="checkbox"/>
15	External: Soffit Cladding	Suspect ACM Board	<input checked="" type="checkbox"/>	<input type="checkbox"/>	<input type="checkbox"/>	<input checked="" type="checkbox"/>	Refer to 003	Good Condition	53.0m2	<input type="checkbox"/>	<input checked="" type="checkbox"/>	<input type="checkbox"/>
16	Internal: Conservatory-Walls	Suspect ACM Board	<input checked="" type="checkbox"/>	<input type="checkbox"/>	<input type="checkbox"/>	<input checked="" type="checkbox"/>	Refer to 004	Good Condition	8.0m2	<input type="checkbox"/>	<input checked="" type="checkbox"/>	<input type="checkbox"/>
17	Internal: Conservatory-Ceiling	Suspect ACM Board	<input checked="" type="checkbox"/>	<input type="checkbox"/>	<input checked="" type="checkbox"/>	<input type="checkbox"/>	005	Good Condition	20.0m2	<input type="checkbox"/>	<input checked="" type="checkbox"/>	<input type="checkbox"/>
18	Internal: Conservatory-Floor	Carpet/Concrete	<input type="checkbox"/>	<input checked="" type="checkbox"/>	<input type="checkbox"/>	<input checked="" type="checkbox"/>	Non-Asbestos	Insignificant Material	Quantity Not Required	<input type="checkbox"/>	<input type="checkbox"/>	<input checked="" type="checkbox"/>
19	Internal: Ceiling Void-Insulation	Batts Product	<input type="checkbox"/>	<input checked="" type="checkbox"/>	<input type="checkbox"/>	<input checked="" type="checkbox"/>	Non-Asbestos	Insignificant Material	Quantity Not Required	<input type="checkbox"/>	<input type="checkbox"/>	<input checked="" type="checkbox"/>
20	Internal: Ceiling Void-(Loose) Insulation Paper	Suspect ACM Paper	<input checked="" type="checkbox"/>	<input type="checkbox"/>	<input type="checkbox"/>	<input checked="" type="checkbox"/>	Refer to 001	Good Condition	10.0m2	<input type="checkbox"/>	<input checked="" type="checkbox"/>	<input type="checkbox"/>
21	Internal: Laundry-Walls	Plasterboard	<input type="checkbox"/>	<input checked="" type="checkbox"/>	<input type="checkbox"/>	<input checked="" type="checkbox"/>	Non-Asbestos	Insignificant Material	Quantity Not Required	<input type="checkbox"/>	<input type="checkbox"/>	<input checked="" type="checkbox"/>
22	Internal: Laundry-Floor	Suspect ACM (Vinyl Backing)	<input checked="" type="checkbox"/>	<input type="checkbox"/>	<input checked="" type="checkbox"/>	<input type="checkbox"/>	006	Good Condition	12.0m2	<input type="checkbox"/>	<input checked="" type="checkbox"/>	<input type="checkbox"/>
23	Internal: Laundry-Ceiling	Suspect ACM (Textured Coating)	<input checked="" type="checkbox"/>	<input type="checkbox"/>	<input checked="" type="checkbox"/>	<input type="checkbox"/>	007	Good Condition	8.0m2	<input checked="" type="checkbox"/>	<input type="checkbox"/>	<input type="checkbox"/>
24	Internal: Toilet-Walls	Plasterboard	<input type="checkbox"/>	<input checked="" type="checkbox"/>	<input type="checkbox"/>	<input checked="" type="checkbox"/>	Non-Asbestos	Insignificant Material	Quantity Not Required	<input type="checkbox"/>	<input type="checkbox"/>	<input checked="" type="checkbox"/>

Location No:	Location Assessed	Material Type Identified	Select if suspect ACM was identified		Select if sample Was collected		Sample No Or enter Non-Asbestos	Condition of ACM or Insignificant material	Quantity m2 Or Quantity Not Required	ACM Friability (Actual condition) Yes = ACM is friable No = ACM is Non-friable Or select N/A
25	Internal: Toilet-Floor	Suspect ACM (Vinyl Backing)	Yes <input checked="" type="checkbox"/>	No <input type="checkbox"/>	Yes <input type="checkbox"/>	No <input checked="" type="checkbox"/>	Refer to 006	Good Condition	2.0m2	Yes No N/A <input type="checkbox"/> <input checked="" type="checkbox"/> <input type="checkbox"/>
26	Internal: Toilet-Ceiling	Suspect ACM (Textured Coating)	Yes <input checked="" type="checkbox"/>	No <input type="checkbox"/>	Yes <input type="checkbox"/>	No <input checked="" type="checkbox"/>	Refer to 007	Good Condition	2.0m2	Yes No N/A <input checked="" type="checkbox"/> <input type="checkbox"/> <input type="checkbox"/>
27	Internal: Bathroom-Walls	Plasterboard	Yes <input type="checkbox"/>	No <input checked="" type="checkbox"/>	Yes <input type="checkbox"/>	No <input checked="" type="checkbox"/>	Non-Asbestos	Insignificant Material	Quantity Not Required	Yes No N/A <input type="checkbox"/> <input type="checkbox"/> <input checked="" type="checkbox"/>
28	Internal: Bathroom-Floor	Suspect ACM (Vinyl Backing)	Yes <input checked="" type="checkbox"/>	No <input type="checkbox"/>	Yes <input type="checkbox"/>	No <input checked="" type="checkbox"/>	Refer to 006	Good Condition	8.0m2	Yes No N/A <input type="checkbox"/> <input checked="" type="checkbox"/> <input type="checkbox"/>
29	Internal: Bathroom-Ceiling	Suspect ACM (Textured Coating)	Yes <input checked="" type="checkbox"/>	No <input type="checkbox"/>	Yes <input type="checkbox"/>	No <input checked="" type="checkbox"/>	Refer to 007	Good Condition	8.0m2	Yes No N/A <input checked="" type="checkbox"/> <input type="checkbox"/> <input type="checkbox"/>
30	Internal: Bedroom 1-Walls	Plasterboard	Yes <input type="checkbox"/>	No <input checked="" type="checkbox"/>	Yes <input type="checkbox"/>	No <input checked="" type="checkbox"/>	Non-Asbestos	Insignificant Material	Quantity Not Required	Yes No N/A <input type="checkbox"/> <input type="checkbox"/> <input checked="" type="checkbox"/>
31	Internal: Bedroom 1-Floor	Carpet/Concrete	Yes <input type="checkbox"/>	No <input checked="" type="checkbox"/>	Yes <input type="checkbox"/>	No <input checked="" type="checkbox"/>	Non-Asbestos	Insignificant Material	Quantity Not Required	Yes No N/A <input type="checkbox"/> <input type="checkbox"/> <input checked="" type="checkbox"/>
32	Internal: Bedroom 1-Ceiling	Plasterboard	Yes <input type="checkbox"/>	No <input checked="" type="checkbox"/>	Yes <input type="checkbox"/>	No <input checked="" type="checkbox"/>	Non-Asbestos	Insignificant Material	Quantity Not Required	Yes No N/A <input type="checkbox"/> <input type="checkbox"/> <input checked="" type="checkbox"/>
33	Internal: Bedroom 2-Walls	Plasterboard	Yes <input type="checkbox"/>	No <input checked="" type="checkbox"/>	Yes <input type="checkbox"/>	No <input checked="" type="checkbox"/>	Non-Asbestos	Insignificant Material	Quantity Not Required	Yes No N/A <input type="checkbox"/> <input type="checkbox"/> <input checked="" type="checkbox"/>
34	Internal: Bedroom 2-Floor	Carpet/Concrete	Yes <input type="checkbox"/>	No <input checked="" type="checkbox"/>	Yes <input type="checkbox"/>	No <input checked="" type="checkbox"/>	Non-Asbestos	Insignificant Material	Quantity Not Required	Yes No N/A <input type="checkbox"/> <input type="checkbox"/> <input checked="" type="checkbox"/>
35	Internal: Bedroom 2-Ceiling	Plasterboard	Yes <input type="checkbox"/>	No <input checked="" type="checkbox"/>	Yes <input type="checkbox"/>	No <input checked="" type="checkbox"/>	Non-Asbestos	Insignificant Material	Quantity Not Required	Yes No N/A <input type="checkbox"/> <input type="checkbox"/> <input checked="" type="checkbox"/>
36	Internal: Hallway-Walls	Plasterboard	Yes <input type="checkbox"/>	No <input checked="" type="checkbox"/>	Yes <input type="checkbox"/>	No <input checked="" type="checkbox"/>	Non-Asbestos	Insignificant Material	Quantity Not Required	Yes No N/A <input type="checkbox"/> <input type="checkbox"/> <input checked="" type="checkbox"/>

Location No:	Locatio Assessed	Material Type Identified	Select if suspect ACM was identified		Select if sample Was collected		Sample No Or enter Non-Asbestos	Condition of ACM or Insignificant material	Quantity m2 Or Quantity Not Required	ACM Friability (Actual condition) Yes = ACM is friable No = ACM is Non-friable Or select N/A
37	Internal: Hallway-Floor	Carpet/Concrete	Yes <input type="checkbox"/>	No ✓	Yes <input type="checkbox"/>	No ✓	Non-Asbestos	Insignificant Material	Quantity Not Required	Yes No N/A <input type="checkbox"/> <input type="checkbox"/> ✓
38	Internal: Hallway-Ceiling	Plasterboard	Yes <input type="checkbox"/>	No ✓	Yes <input type="checkbox"/>	No ✓	Non-Asbestos	Insignificant Material	Quantity Not Required	Yes No N/A <input type="checkbox"/> <input type="checkbox"/> ✓
39	Internal: Hallway-Wood Burner	Door Seal Synthetic Product	Yes <input type="checkbox"/>	No ✓	Yes <input type="checkbox"/>	No ✓	Non-Asbestos	Insignificant Material	Quantity Not Required	Yes No N/A <input type="checkbox"/> <input type="checkbox"/> ✓
40	Internal: Side Entry Lobby-Walls	Plasterboard	Yes <input type="checkbox"/>	No ✓	Yes <input type="checkbox"/>	No ✓	Non-Asbestos	Insignificant Material	Quantity Not Required	Yes No N/A <input type="checkbox"/> <input type="checkbox"/> ✓
41	Internal: Side Entry Lobby-Floor	Carpet/Concrete	Yes <input type="checkbox"/>	No ✓	Yes <input type="checkbox"/>	No ✓	Non-Asbestos	Insignificant Material	Quantity Not Required	Yes No N/A <input type="checkbox"/> <input type="checkbox"/> ✓
42	Internal: Side Entry Lobby-Ceiling	Plasterboard	Yes <input type="checkbox"/>	No ✓	Yes <input type="checkbox"/>	No ✓	Non-Asbestos	Insignificant Material	Quantity Not Required	Yes No N/A <input type="checkbox"/> <input type="checkbox"/> ✓
43	Internal: Lounge-Walls	Plasterboard	Yes <input type="checkbox"/>	No ✓	Yes <input type="checkbox"/>	No ✓	Non-Asbestos	Insignificant Material	Quantity Not Required	Yes No N/A <input type="checkbox"/> <input type="checkbox"/> ✓
44	Internal: Lounge-Floor	Carpet/Concrete	Yes <input type="checkbox"/>	No ✓	Yes <input type="checkbox"/>	No ✓	Non-Asbestos	Insignificant Material	Quantity Not Required	Yes No N/A <input type="checkbox"/> <input type="checkbox"/> ✓
45	Internal: Lounge-Ceiling	Plasterboard	Yes <input type="checkbox"/>	No ✓	Yes <input type="checkbox"/>	No ✓	Non-Asbestos	Insignificant Material	Quantity Not Required	Yes No N/A <input type="checkbox"/> <input type="checkbox"/> ✓
46	Internal: Master Bedroom-Walls	Plasterboard	Yes <input type="checkbox"/>	No ✓	Yes <input type="checkbox"/>	No ✓	Non-Asbestos	Insignificant Material	Quantity Not Required	Yes No N/A <input type="checkbox"/> <input type="checkbox"/> ✓
47	Internal: Master Bedroom-Floor	Carpet/Concrete	Yes <input type="checkbox"/>	No ✓	Yes <input type="checkbox"/>	No ✓	Non-Asbestos	Insignificant Material	Quantity Not Required	Yes No N/A <input type="checkbox"/> <input type="checkbox"/> ✓
48	Internal: Master Bedroom-Ceiling	Plasterboard	Yes <input type="checkbox"/>	No ✓	Yes <input type="checkbox"/>	No ✓	Non-Asbestos	Insignificant Material	Quantity Not Required	Yes No N/A <input type="checkbox"/> <input type="checkbox"/> ✓

Location No:	Location Assessed	Material Type Identified	Select if suspect ACM was identified		Select if sample Was collected		Sample No Or enter Non-Asbestos	Condition of ACM or Insignificant material	Quantity m2 Or Quantity Not Required	ACM Friability (Actual condition) Yes = ACM is friable No = ACM is Non-friable Or select N/A
49	Internal: Ensuite-Walls	Plasterboard	Yes <input type="checkbox"/>	No ✓	Yes <input type="checkbox"/>	No ✓	Non-Asbestos	Insignificant Material	Quantity Not Required	Yes No N/A <input type="checkbox"/> <input type="checkbox"/> ✓
50	Internal: Ensuite-Floor	Hard Tiles	Yes <input type="checkbox"/>	No ✓	Yes <input type="checkbox"/>	No ✓	Non-Asbestos	Insignificant Material	Quantity Not Required	Yes No N/A <input type="checkbox"/> <input type="checkbox"/> ✓
51	Internal: Ensuite-Ceiling	Suspect ACM (Textured Coating)	Yes ✓	No <input type="checkbox"/>	Yes ✓	No <input type="checkbox"/>	008	Good Condition	4.0m2	Yes No N/A <input type="checkbox"/> <input type="checkbox"/> <input type="checkbox"/>
52	Internal: Kitchen-Walls	Plasterboard	Yes <input type="checkbox"/>	No ✓	Yes <input type="checkbox"/>	No ✓	Non-Asbestos	Insignificant Material	Quantity Not Required	Yes No N/A <input type="checkbox"/> <input type="checkbox"/> ✓
53	Internal: Kitchen-Floor	Hard Tile	Yes <input type="checkbox"/>	No ✓	Yes <input type="checkbox"/>	No ✓	Non-Asbestos	Insignificant Material	Quantity Not Required	Yes No N/A <input type="checkbox"/> <input type="checkbox"/> ✓
54	Internal: Kitchen-Ceiling	Plasterboard	Yes <input type="checkbox"/>	No ✓	Yes <input type="checkbox"/>	No ✓	Non-Asbestos	Insignificant Material	Quantity Not Required	Yes No N/A <input type="checkbox"/> <input type="checkbox"/> ✓
55	Internal: Dining Room-Walls	Plasterboard	Yes <input type="checkbox"/>	No ✓	Yes <input type="checkbox"/>	No ✓	Non-Asbestos	Insignificant Material	Quantity Not Required	Yes No N/A <input type="checkbox"/> <input type="checkbox"/> ✓
56	Internal: Dining Room-Floor	Hard Tile	Yes <input type="checkbox"/>	No ✓	Yes <input type="checkbox"/>	No ✓	Non-Asbestos	Insignificant Material	Quantity Not Required	Yes No N/A <input type="checkbox"/> <input type="checkbox"/> ✓
57	Internal: Dining Room-Ceiling	Plasterboard	Yes <input type="checkbox"/>	No ✓	Yes <input type="checkbox"/>	No ✓	Non-Asbestos	Insignificant Material	Quantity Not Required	Yes No N/A <input type="checkbox"/> <input type="checkbox"/> ✓
58	External: Rear Fence Lining	Suspect ACM Board	Yes ✓	No <input type="checkbox"/>	Yes ✓	No <input type="checkbox"/>	009	Partly Damaged	28.0m2	Yes No N/A <input type="checkbox"/> ✓ <input type="checkbox"/>
59	External: Garage-Roof	Iron Product	Yes <input type="checkbox"/>	No ✓	Yes <input type="checkbox"/>	No ✓	Non-Asbestos	Insignificant Material	Quantity Not Required	Yes No N/A <input type="checkbox"/> <input type="checkbox"/> ✓
60	External: Garage-Walls	Brick Building Product	Yes <input type="checkbox"/>	No ✓	Yes <input type="checkbox"/>	No ✓	Non-Asbestos	Insignificant Material	Quantity Not Required	Yes No N/A <input type="checkbox"/> <input type="checkbox"/> ✓

Location No:	Location Assessed	Material Type Identified	Select if suspect ACM was identified		Select if sample Was collected		Sample No Or enter Non-Asbestos	Condition of ACM or Insignificant material	Quantity m2 Or Quantity Not Required	ACM Friability (Actual condition) Yes = ACM is friable No = ACM is Non-friable Or select N/A
--------------	-------------------	--------------------------	--------------------------------------	--	--------------------------------	--	---------------------------------	--	--------------------------------------	---

61	External: Garage (South Side)	Suspect ACM (Loose Fragments)	Yes <input checked="" type="checkbox"/>	No <input type="checkbox"/>	Yes <input checked="" type="checkbox"/>	No <input type="checkbox"/>	010	Scattered Fragments	36.0m2	Yes No N/A <input type="checkbox"/> <input checked="" type="checkbox"/> <input type="checkbox"/>
62	Internal: Garage-Insulation Paper	Suspect ACM Paper	Yes <input checked="" type="checkbox"/>	No <input type="checkbox"/>	Yes <input checked="" type="checkbox"/>	No <input type="checkbox"/>	011	Partly Damaged	72.0m2	Yes No N/A <input type="checkbox"/> <input checked="" type="checkbox"/> <input type="checkbox"/>
63	Internal: Garage-Electrical Fuse Board	Suspect ACM Board	Yes <input checked="" type="checkbox"/>	No <input type="checkbox"/>	Yes <input checked="" type="checkbox"/>	No <input type="checkbox"/>	012	Good Condition	.300m2	Yes No N/A <input type="checkbox"/> <input checked="" type="checkbox"/> <input type="checkbox"/>
64	Internal: Garage-South End (Wall Panels)	Suspect ACM Board	Yes <input checked="" type="checkbox"/>	No <input type="checkbox"/>	Yes <input type="checkbox"/>	No <input checked="" type="checkbox"/>	Refer to 010	Partly Damaged	15.0m2	Yes No N/A <input type="checkbox"/> <input checked="" type="checkbox"/> <input type="checkbox"/>
65			Yes <input type="checkbox"/>	No <input type="checkbox"/>	Yes <input type="checkbox"/>	No <input type="checkbox"/>				Yes No N/A <input type="checkbox"/> <input type="checkbox"/> <input type="checkbox"/>
66			Yes <input type="checkbox"/>	No <input type="checkbox"/>	Yes <input type="checkbox"/>	No <input type="checkbox"/>				Yes No N/A <input type="checkbox"/> <input type="checkbox"/> <input type="checkbox"/>
67			Yes <input type="checkbox"/>	No <input type="checkbox"/>	Yes <input type="checkbox"/>	No <input type="checkbox"/>				Yes No N/A <input type="checkbox"/> <input type="checkbox"/> <input type="checkbox"/>
68			Yes <input type="checkbox"/>	No <input type="checkbox"/>	Yes <input type="checkbox"/>	No <input type="checkbox"/>				Yes No N/A <input type="checkbox"/> <input type="checkbox"/> <input type="checkbox"/>
69			Yes <input type="checkbox"/>	No <input type="checkbox"/>	Yes <input type="checkbox"/>	No <input type="checkbox"/>				Yes No N/A <input type="checkbox"/> <input type="checkbox"/> <input type="checkbox"/>
70			Yes <input type="checkbox"/>	No <input type="checkbox"/>	Yes <input type="checkbox"/>	No <input type="checkbox"/>				Yes No N/A <input type="checkbox"/> <input type="checkbox"/> <input type="checkbox"/>
71			Yes <input type="checkbox"/>	No <input type="checkbox"/>	Yes <input type="checkbox"/>	No <input type="checkbox"/>				Yes No N/A <input type="checkbox"/> <input type="checkbox"/> <input type="checkbox"/>
72			Yes <input type="checkbox"/>	No <input type="checkbox"/>	Yes <input type="checkbox"/>	No <input type="checkbox"/>				Yes No N/A <input type="checkbox"/> <input type="checkbox"/> <input type="checkbox"/>

Site Plan 1

Left-side Rear Boundary

Right-side Rear Boundary



Asbestos register:





Laboratory Results Negative	Laboratory Results Positive	Presumed Presence of Asbestos or ACM	ACM has been removed, ACM has been sealed and encapsulated. "CAUTION"
-----------------------------	-----------------------------	--------------------------------------	---

Workplace Information:

**36 Rahui Road, Otaki
New Zealand.**

Relinquished by:

Asbestos Inspection Services Limited.
Bruce Wakefield
0277655123
bruce.wakefield@aisl.co.nz
www@aisl.co.nz

Date of Identification	Specific Location	Type of Asbestos	Condition of Asbestos	Is it Friable or Non-Friable?	Laboratory Analysis findings	Photos
7 th November 2017.	External: Wall Framing Paper 001	Suspect ACM Paper	Good Condition	Non-Friable	No Asbestos Detected	
7 th November 2017.	External: Fuse Board (Front Entry) 002	Suspect ACM Board	Good Condition	Non-Friable	No Asbestos Detected	
7 th November 2017.	External: Front Entry-Ceiling 003	Suspect ACM Board	Partly Damaged	Non-Friable	Chrysotile (White)	
7 th November 2017.	External: Front Entry-Outer Wall Cladding 004	Suspect ACM Board	Partly Damaged	Non-Friable	Chrysotile (White)	

Asbestos register:





Laboratory Results Negative	Laboratory Results Positive	Presumed Presence of Asbestos or ACM	ACM has been removed, ACM has been sealed and encapsulated. "CAUTION"
--------------------------------	--------------------------------	---	--

Workplace Information:

**36 Rahui Road, Otaki
New Zealand.**

Relinquished by:

Asbestos Inspection Services Limited.
Bruce Wakefield
0277655123
bruce.wakefield@aisl.co.nz
www@aisl.co.nz

Date of Identification	Specific Location	Type of Asbestos	Condition of Asbestos	Is it Friable or Non-Friable?	Laboratory Analysis findings	Action Required
7 th November 2017.	External: Side Entry-Outer Wall Cladding Refer to 004	Suspect ACM Board	Good Condition	Non-Friable	Chrysotile (White)	
7 th November 2017.	External: Side Entry-Ceiling Material Refer to 003	Suspect ACM Board	Good Condition	Non-Friable	Chrysotile (White)	
7 th November 2017.	External: Soffit Cladding Refer to 003	Suspect ACM Board	Good Condition	Non-Friable	Chrysotile (White)	
7 th November 2017.	Internal: Conservatory-Walls Refer to 004	Suspect ACM Board	Good Condition	Non-Friable	Chrysotile (White)	

Asbestos register:



Laboratory Results Negative	Laboratory Results Positive	Presumed Presence of Asbestos or ACM	ACM has been removed, ACM has been sealed and encapsulated. "CAUTION"
-----------------------------	-----------------------------	--------------------------------------	---

Workplace Information:

**36 Rahui Road, Otaki
New Zealand.**

Relinquished by:

Asbestos Inspection Services Limited.
Bruce Wakefield
0277655123
bruce.wakefield@aisl.co.nz
www@aisl.co.nz

Date of Identification	Specific Location	Type of Asbestos	Condition of Asbestos	Is it Friable or Non-Friable?	Laboratory Analysis findings	Action Required
7 th November 2017.	Internal: Conservatory-Ceiling 005	Suspect ACM Board	Good Condition	Non-Friable	Chrysotile (White)	
7 th November 2017.	Internal: Ceiling Void-(Loose) Insulation Paper Refer to 001	Suspect ACM Paper	Good Condition	Non-Friable	No Asbestos Detected	Photo Not Taken
7 th November 2017.	Internal: Laundry-Floor 006	Suspect ACM (Vinyl Backing)	Good Condition	Non-Friable	Chrysotile (White)	
7 th November 2017.	Internal: Laundry-Ceiling 007	Suspect ACM (Textured Coating)	Good Condition	Non-Friable	No Asbestos Detected	

Asbestos register:





Laboratory Results Negative	Laboratory Results Positive	Presumed Presence of Asbestos or ACM	ACM has been removed, ACM has been sealed and encapsulated. "CAUTION"
-----------------------------	-----------------------------	--------------------------------------	---

Workplace Information:

**36 Rahui Road, Otaki
New Zealand.**

Relinquished by:

Asbestos Inspection Services Limited.
Bruce Wakefield
0277655123
bruce.wakefield@aisl.co.nz
www@aisl.co.nz

Date of Identification	Specific Location	Type of Asbestos	Condition of Asbestos	Is it Friable or Non-Friable?	Laboratory Analysis findings	Action Required
7 th November 2017.	Internal: Toilet-Floor Refer to 006	Suspect ACM (Vinyl Backing)	Good Condition	Non-Friable	Chrysotile (White)	
7 th November 2017.	Internal: Toilet-Ceiling Refer to 007	Suspect ACM (Textured Coating)	Good Condition	Non-Friable	No Asbestos Detected	
7 th November 2017.	Internal: Bathroom-Floor Refer to 006	Suspect ACM (Vinyl Backing)	Good Condition	Non-Friable	Chrysotile (White)	
7 th November 2017.	Internal: Bathroom-Ceiling Refer to 007	Suspect ACM (Textured Coating)	Good Condition	Non-Friable	No Asbestos Detected	

Asbestos register:





Laboratory Results Negative	Laboratory Results Positive	Presumed Presence of Asbestos or ACM	ACM has been removed, ACM has been sealed and encapsulated. "CAUTION"
-----------------------------	-----------------------------	--------------------------------------	---

Workplace Information:

**36 Rahui Road, Otaki
New Zealand.**

Relinquished by:

Asbestos Inspection Services Limited.
Bruce Wakefield
0277655123
bruce.wakefield@aisl.co.nz
www@aisl.co.nz

Date of Identification	Specific Location	Type of Asbestos	Condition of Asbestos	Is it Friable or Non-Friable?	Laboratory Analysis findings	Action Required
7 th November 2017.	Internal: Ensuite-Ceiling 008	Suspect ACM (Textured Coating)	Good Condition	Non-Friable	No Asbestos Detected	
7 th November 2017.	External: Rear Fence Lining 009	Suspect ACM Board	Partly Damaged	Non-Friable	No Asbestos Detected	
7 th November 2017.	External: Garage - (South Side) 010	Suspect ACM (Loose Fragments)	Loose Fragments	Non-Friable	Chrysotile (White)	
7 th November 2017.	Internal: Garage-Insulation Paper 011	Suspect ACM Paper	Partly Damaged	Non-Friable	No Asbestos Detected	

Asbestos register:

Laboratory Results Negative	Laboratory Results Positive	Presumed Presence of Asbestos or ACM	ACM has been removed, ACM has been sealed and encapsulated. "CAUTION"
-----------------------------	-----------------------------	--------------------------------------	---

Workplace Information:

**36 Rahui Road, Otaki
New Zealand.**

Relinquished by:

Asbestos Inspection Services Limited.
Bruce Wakefield
0277655123
bruce.wakefield@aisl.co.nz
www@aisl.co.nz

Date of Identification	Specific Location	Type of Asbestos	Condition of Asbestos	Is it Friable or Non-Friable?	Laboratory Analysis findings	Action Required
7 th November 2017.	Internal: Garage-Electrical Fuse Board 012	Suspect ACM Board	Good Condition	Non-Friable	No Asbestos Detected	
7 th November 2017.	Internal: Garage-South End (Wall Panels) Refer to 010	Suspect ACM Board	Partly Damaged	Non-Friable	Chrysotile (White)	
7 th November 2017.						
7 th November 2017.						

Jane Rendall

From: Damien Moloney (Construction Infrastructure) <DamienM@fcc.co.nz>
Sent: Thursday, 23 November 2017 9:40 AM
To: Chris Hillman
Subject: FW: Rahui Road Markup

Chris,

Please see info in relation to Asbestos reports for the requested properties.

Regards

Damien Moloney

Project Engineer | Infrastructure

The Fletcher Construction Company Ltd

2 Ake Ake Place, Otaki, 5512.

Ph: + **Mob:** +64 27 405 7261 **Email:** damienm@fcc.co.nz

From: Mark Anderson [mailto:M.Anderson@higgins.co.nz]
Sent: Thursday, 23 November 2017 8:01 a.m.
To: Damien Moloney (Construction Infrastructure) <DamienM@fcc.co.nz>
Subject: RE: Rahui Road Markup

Damien,

Still waiting for the report for 32 Rahui. I spoke to RDL yesterday & apparently there was some mix up between Wellington & Palmy branches & they didn't get sent through. Hoping to have them by end of week. 34 Rahui we didn't get a survey on but the garage was tin cladding & there was no sign of ACMs so we self-demolished & separated out into concrete, scrap metal & construction rubbish. Central demolition took the rubbish away in their truck.

Cheers,

Mark Anderson

Project Engineer (Drainage/Utilities)

Higgins *showing the way*

Unit 2 & 3, 2 Ake Ake Place, Otaki |

Mob: +64 27 4111005 **Email:** m.anderson@higgins.co.nz

Site Office: PP20 Otaki Project Office, Unit 2 & 3, 2 Ake Ake Place, Otaki |

From: Damien Moloney (Construction Infrastructure) [<mailto:DamienM@fcc.co.nz>]
Sent: Wednesday, 22 November 2017 7:38 a.m.
To: Mark Anderson
Subject: FW: Rahui Road Markup

Mark,

Did you get the report back for No 32 yet?

Also is there a report for the garage on no 34?

Regards

Damien Moloney

Project Engineer | Infrastructure

The Fletcher Construction Company Ltd

2 Ake Ake Place, Otaki, 5512.

Ph: + Mob: +64 27 405 7261 Email: damienm@fcc.co.nz

From: Chris Hillman [<mailto:CHillman@tonkintaylor.co.nz>]
Sent: Friday, 17 November 2017 11:53 a.m.
To: Damien Moloney (Construction Infrastructure) <DamienM@fcc.co.nz>
Subject: RE: Rahui Road Markup

Hi Damien,

What were the results for the surveys at:

- No.32?
- No. 34 Garage (was that negative for asbestos, like the house?)

Cheers

Chris

From: Damien Moloney (Construction Infrastructure) [<mailto:DamienM@fcc.co.nz>]
Sent: Tuesday, 14 November 2017 1:50 PM
To: Chris Hillman <CHillman@tonkintaylor.co.nz>
Cc: Richard Rakovics (Construction Infrastructure) <RichardR@fcc.co.nz>; Steve Findlay (Construction Infrastructure) <SteveF@fcc.co.nz>
Subject: Rahui Road Markup

Hi Chris,

On the basis of yesterday's discussion, please find attached mark up with comments in relation to the properties that are located in Rahui Road.

In addition to this please find one of the reports for one of the properties, Rahui Road no 36. (email subject is incorrect)

On the basis of this please advise what testing you require in this area? Also can you advise how soon one of your engineers can come to site as we would like to get these works underway ASAP.

Regards

Damien Moloney

Project Engineer | Infrastructure

The Fletcher Construction Company Ltd

2 Ake Ake Place, Otaki, 5512.

Ph: + Mob: +64 27 405 7261 Email: damienm@fcc.co.nz

NOTICE: This email together with any attachments is confidential, may be subject to legal privilege and may contain proprietary information, including information protected by copyright. If you are not the intended recipient, please do not copy, use or disclose the information in it, and confidentiality and privilege are not waived. If you have received this in error, please notify us immediately by return email and delete this email.

Appendix D

SUMMARY OF ANALYTICAL RESULTS

Site	Location	Depth (m)	Soil type	Description	Result
KiwiRail Designation (Main Line)	A1	Surface	Ballast	Ballast: Cobbly GRAVEL, grey, loose, dry	No asbestos detected
	A1	0.75	Ballast		No asbestos detected
	A1	0.9	Ballast		No asbestos detected
	A2	0.9	Ballast		No asbestos detected
	A3	0.0	Ballast		No asbestos detected
	A3	0.8	Ballast		No asbestos detected
	A4	Surface	Ballast		No asbestos detected
	A5	Surface	Ballast		No asbestos detected
	A6	0.3	Ballast		No asbestos detected
	A6	0.75	Ballast		No asbestos detected
	A7	Surface	Ballast		No asbestos detected
	A7	1.1	clay	Sandy, gravelly CLAY, moist, orange brown, non-plastic, firm	No asbestos detected
	A8	Surface	Ballast	Ballast: Cobbly GRAVEL, grey, loose, dry	No asbestos detected
	A9	Surface	Ballast		No asbestos detected
	A9	0.4	Ballast		No asbestos detected
	A9	0.9	Ballast		No asbestos detected
	A10	0.75	clay	Silty CLAY, medium grey brown, with trace organics, moist to wet	No asbestos detected
	11.10	Surface	Ballast	Ballast: Cobbly GRAVEL, grey, loose, dry	No asbestos detected
	11.09	Surface	Ballast		No asbestos detected
	11.08	Surface	Ballast		No asbestos detected
	11.07	Surface	Ballast		No asbestos detected
	11.06	Surface	Ballast		No asbestos detected
	11.05	Surface	Ballast		No asbestos detected
	11.04	Surface	Ballast		No asbestos detected
	11.03	Surface	Ballast		0.035%
	11.02	Surface	Ballast		0.023%
	11.01	Surface	Ballast		No asbestos detected
	A11	Surface	Ballast		0.016%
	11.11	Surface	Ballast		No asbestos detected
	11.12	Surface	Ballast		No asbestos detected
	11.13	Surface	Ballast		No asbestos detected
	11.14	Surface	Ballast		No asbestos detected
	11.15	Surface	Ballast		No asbestos detected
A12	Surface	Ballast	No asbestos detected		
A13	0.2	Ballast	No asbestos detected		
A14	Surface	Ballast	<0.001%		
A14	0.2	Ballast	No asbestos detected		
A15	Surface	Ballast	No asbestos detected		
A16	Surface	Ballast	No asbestos detected		
A16	0.3	Ballast	No asbestos detected		
A17	0.5	Ballast	<0.001%		

Site	Location	Depth (m)	Soil type	Description	Result
	17.01	Surface	Ballast	Ballast: Cobbly GRAVEL, grey, loose, dry	No asbestos detected
	17.02	Surface	Ballast		No asbestos detected
	17.03	Surface	Ballast		No asbestos detected
	17.04	Surface	Ballast		No asbestos detected
	17.05	Surface	Ballast		No asbestos detected
	17.06	Surface	Ballast		No asbestos detected
	A18	Surface	Ballast		No asbestos detected
	A19	Surface	Ballast		No asbestos detected

Site	Location	Depth (m)	Soil type	Description	Result
Ōtaki Sidings	TP 116	0.3	Ballast	Ballast: Sandy GRAVEL medium to coarse, brown grey, moist	<0.001%
	TP 117	Surface	Ballast		No asbestos detected
	TP 118	Surface	Ballast		No asbestos detected
	TP 118	0.2	Ballast		No asbestos detected
	TP 118	Surface	Ballast		No asbestos detected
	TP 120	Surface	Ballast		No asbestos detected
	TP 121	0.7	Silt	SILT, medium grey brown, moist, stiff	No asbestos detected
	TP 122	0.9	Gravel	Sandy GRAVEL with demolition material, dark brown, tightly packed	<0.001%
	TP 123	0.1	Gravel	Sandy GRAVEL, med grey, well graded, moist	No asbestos detected
	TP 124	Surface	Gravel	sandy GRAVEL med grey, moist	No asbestos detected
	TP 124	0.5	Silt	SILT medium grey brown, with minor/some orange mottling, dry to moist	No asbestos detected
	TP 125	Surface	Ballast	Ballast: Sandy GRAVEL medium to coarse, brown grey, moist to wet	No asbestos detected

Site	Location	Depth (m)	Soil type	Description	Result
Rahui Road	TP 106	Surface	Silt	SILT with minor clay, wet, minor gravels	0.003%
	TP 106	0.2	Gravel	Sandy GRAVEL, medium to coarse, dark grey, moist	<0.001%
	TP 107	Surface	Silt	SILT with minor clay, wet, some medium to coarse gravel, dark brown, trace refuse	No asbestos detected
	TP 107	0.4	Silt	SILT trace clay, dark brown, moist	No asbestos detected
	200	Surface	Silt	SILT with minor clay, wet, some medium to coarse gravel, dark brown	No asbestos detected
	201	Surface	Silt		No asbestos detected
	203	Surface	Silt		No asbestos detected

Site	Location	Depth (m)	Soil type		Result
	204	Surface	Silt		No asbestos detected
	205	Surface	Silt		<0.001%
	206	Surface	Silt		No asbestos detected
	207	Surface	Silt		No asbestos detected
	209	Surface	Silt	SILT with minor clay, wet, some medium to coarse gravel, dark brown	No asbestos detected
	210	Surface	Silt		No asbestos detected
	211	Surface	Silt		No asbestos detected
	212	Surface	Silt		No asbestos detected
	214 N	Surface	Silt		No asbestos detected
	214 S	Surface	Silt		No asbestos detected
	215 W	Surface	Silt		No asbestos detected
	215 E	Surface	Silt		No asbestos detected
	217 E	Surface	Silt		No asbestos detected
	218 N	Surface	Silt		No asbestos detected

Appendix E

LABORATORY TRANSCRIPTS



PRECISE

CONSULTING & LABORATORY

Report Date: 27 Oct 2017

Certificate Number: W1710160907

Tonkin and Taylor
Level 4, 2 Hunter Street, Wellington

Client Reference: 85985.007

Dear Natalie Pilcher,

Re: Asbestos Soil Identification Analysis – Otaki Railway

28 sample(s) received on 16 Oct 2017 by Kristina Prokhanova.

The results of fibre analysis were performed by Laura Liu of Precise Consulting and Laboratory Ltd on 24 Oct 2017.

The sample(s) were stated to be from Otaki Railway.

Sample analysis was performed using polarised light microscopy with dispersion staining in accordance with *AS4964-2004 Method for the qualitative identification of asbestos in soil samples*.

The results of the fibre analysis are presented in the appended table.

Should you require further information please contact Laura Liu .

Yours sincerely

Laura Liu

PRECISE LABORATORY IDENTIFIER

Sample Analysis Results

Certificate Number: W1710160907
Report Date: 27 Oct 2017
Site Location: Otaki Railway



PRECISE

CONSULTING & LABORATORY

Note 1: The reporting limit for this analysis is 0.1g/kg (0.01%) by application of polarised light microscopy, dispersion staining and trace analysis techniques.

Note 2: If mineral fibres of unknown type are detected (UMF), by PLM and dispersion staining, these may or may not be asbestos fibres. To confirm the identity of this fibre, another independent analytical technique such as XRD analysis is advised.

Note 3: The samples in this report are "As Received". The laboratory does not take responsibility for the sampling procedure or accuracy of sample location description. This document may not be reproduced except in full.

Identified by:

Reviewed by:

Approved Identifier: Laura Liu

Key Technical Person: Laura Liu

Sample ID	Client Sample ID	Sample Location/Description/Dimensions	Analysis Results
A1	A1	10L Bucket Non-Homogeneous Soil -g	No Asbestos Detected Organic Fibres
A1 0.75	A1 0.75	500ml bag Non-Homogeneous Soil 714.0g	No Asbestos Detected Organic Fibres
A1 0.9	A1 0.9	500ml bag Non-Homogeneous Soil 562.5g	No Asbestos Detected Organic Fibres
A2 0.9	A2 0.9	500ml bag Non-Homogeneous Soil 616.0g	No Asbestos Detected Organic Fibres
A3 0.0	A3 0.0	10L Bucket Non-Homogeneous Soil -g	No Asbestos Detected Organic Fibres
A3 0.8	A3 0.8	500ml bag Non-Homogeneous Soil 626.0g	No Asbestos Detected Organic Fibres
A4	A4	10L bag Non-Homogeneous Soil -g	No Asbestos Detected Organic Fibres
A5	A5	10L bag Non-Homogeneous Soil -g	No Asbestos Detected Organic Fibres
A6 0.3	A6 0.3	500ml bag Non-Homogeneous Soil 760.5g	No Asbestos Detected Organic Fibres

Sample Analysis Results

Certificate Number: W1710160907
 Report Date: 27 Oct 2017
 Site Location: Otaki Railway



PRECISE

CONSULTING & LABORATORY

Sample ID	Client Sample ID	Sample Location/Description/Dimensions	Analysis Results
A6 0.75	A6 0.75	500ml bag Non-Homogeneous Soil 510.0g	No Asbestos Detected Organic Fibres
A7 0.0	A7 0.0	10L bag Non-Homogeneous Soil -g	No Asbestos Detected Organic Fibres Synthetic Mineral Fibres
A7 1.1	A7 1.1	500ml bag Non-Homogeneous Soil 483.5g	No Asbestos Detected Organic Fibres
A8 0.0	A8 0.0	10L bucket Non-Homogeneous Soil -g	No Asbestos Detected Organic Fibres
A9 0.0	A9 0.0	10L bag Non-Homogeneous Soil -g	No Asbestos Detected Organic Fibres Synthetic Mineral Fibres
A9 0.4	A9 0.4	500ml bag Non-Homogeneous Soil 348.0g	No Asbestos Detected Organic Fibres
A9 0.9	A9 0.9	500ml bag Non-Homogeneous Soil 441.0g	No Asbestos Detected Organic Fibres
A10 0.75	A10 0.75	500ml bag Non-Homogeneous Soil 397.0g	No Asbestos Detected Organic Fibres
A11	A11	10L bag Non-Homogeneous Soil 205.0g	Chrysotile (white asbestos) Fibres Organic Fibres
A12	A12	10L bag Non-Homogeneous Soil 519.0g	No Asbestos Detected Organic Fibres
A13 0.2	A13 0.2	500ml bag Non-Homogeneous Soil 685.0g	No Asbestos Detected Organic Fibres
A14	A14	10L bag Non-Homogeneous Soil -g	Chrysotile (white asbestos) Fibres Organic Fibres
A14 0.2	A14 0.2	500ml bag Non-Homogeneous Soil 550.5g	No Asbestos Detected Organic Fibres
A15	A15	10L bag Non-Homogeneous Soil -g	No Asbestos Detected Organic Fibres Synthetic Mineral Fibres
A16	A16	10L bag Non-Homogeneous Soil 168.0g	No Asbestos Detected Organic Fibres
A16 0.3	A16 0.3	500ml bag Non-Homogeneous Soil 554.5g	No Asbestos Detected Organic Fibres
A17 0.5	A17 0.5	500ml bag Non-Homogeneous Soil 617.5g	Chrysotile (white asbestos) Fibres Organic Fibres
A18	A18	10L bag Non-Homogeneous Soil	No Asbestos Detected Organic Fibres

Sample Analysis Results

Certificate Number: W1710160907

Report Date: 27 Oct 2017

Site Location: Otaki Railway



PRECISE

CONSULTING & LABORATORY

Sample ID	Client Sample ID	Sample Location/Description/Dimensions	Analysis Results
		-g	
A19	A19	10L bag Non-Homogeneous Soil -g	No Asbestos Detected Organic Fibres

Appendix 1: Soil Analysis Raw Data

Certificate Number: W1710160907
 Report Date: 27 Oct 2017
 Site Location: Otaki Railway



PRECISE

CONSULTING & LABORATORY

Sample ID	Client Sample ID	Sample Weights						>7mm Asbestos Containing Material (ACM)*		Asbestos Fines/Fibrous Asbestos*				Trace Asbestos Detected**
		Total 10L (Kg)	Total 500mL Sub-Sample (g)	>7mm Fraction (g)	2-7mm Fraction (g)	<2mm Sub Sample (g)	<2mm Excess (g)	>7mm ACM (g)	Form & %***	2-7mm ACM (g)	Form & %***	<2mm ACM (g)	Form & %***	
A1	A1	14.75	-	-	-	26.0	-	-	-	-	-	-	-	N
A1 0.75	A1 0.75	-	714.0	638.0	27.0	62.0	-	-	-	-	-	-	-	N
A1 0.9	A1 0.9	-	562.5	271.0	181.0	99.0	11.5	-	-	-	-	-	-	N
A2 0.9	A2 0.9	-	616.0	304.5	149.5	98.0	64.5	-	-	-	-	-	-	N
A3 0.0	A3 0.0	13.45	-	-	-	50.0	-	-	-	-	-	-	-	N
A3 0.8	A3 0.8	-	626.0	451.0	42.5	98.5	32.0	-	-	-	-	-	-	N
A4	A4	13.45	-	-	-	42.5	-	-	-	-	-	-	-	N
A5	A5	15.0	-	-	-	22.5	-	-	-	-	-	-	-	N
A6 0.3	A6 0.3	-	760.5	603.5	94.0	66.0	-	-	-	-	-	-	-	N
A6 0.75	A6 0.75	-	510.0	208.0	185.0	103.0	18.5	-	-	-	-	-	-	N
A7 0.0	A7 0.0	15.45	-	-	-	11.0	-	-	-	-	-	-	-	N
A7 1.1	A7 1.1	-	483.5	170.0	113.5	98.0	101.5	-	-	-	-	-	-	N
A8 0.0	A8 0.0	14.75	-	-	-	24.0	-	-	-	-	-	-	-	N
A9 0.0	A9 0.0	14.95	-	-	-	52.0	-	-	-	-	-	-	-	N
A9 0.4	A9 0.4	-	348.0	194.5	57.0	95.5	22.5	-	-	-	-	-	-	N

Appendix 1: Soil Analysis Raw Data

Certificate Number: W1710160907
 Report Date: 27 Oct 2017
 Site Location: Otaki Railway



PRECISE

CONSULTING & LABORATORY

Sample ID	Client Sample ID	Sample Weights						>7mm Asbestos Containing Material (ACM)*		Asbestos Fines/Fibrous Asbestos*				Trace Asbestos Detected**
		Total 10L (Kg)	Total 500mL Sub-Sample (g)	>7mm Fraction (g)	2-7mm Fraction (g)	<2mm Sub Sample (g)	<2mm Excess (g)	>7mm ACM (g)	Form & %***	2-7mm ACM (g)	Form & %***	<2mm ACM (g)	Form & %***	
A9 0.9	A9 0.9	-	441.0	269.0	85.5	86.0	-	-	-	-	-	-	-	N
A10 0.75	A10 0.75	-	397.0	-	-	99.5	298.5	-	-	-	-	-	-	N
A11	A11	14.95	205.0	-	82.5	104.5	18.0	-	-	-	-	0.0280	100% Free Fibres	Y
A12	A12	15.80	519.0	-	482.0	37.0	-	-	-	-	-	-	-	N
A13 0.2	A13 0.2	-	685.0	436.5	155.5	87.5	-	-	-	-	-	-	-	N
A14	A14	14.15	-	-	-	33.5	-	-	-	-	-	0.0208	100% Free Fibres	Y
A14 0.2	A14 0.2	-	550.5	374.0	69.0	106.5	-	-	-	-	-	-	-	N
A15	A15	14.15	-	-	-	15.5	-	-	-	-	-	-	-	N
A16	A16	13.45	168.0	-	130.5	38.5	-	-	-	-	-	-	-	N
A16 0.3	A16 0.3	-	554.5	325.0	92.0	101.0	36.5	-	-	-	-	-	-	N
A17 0.5	A17 0.5	-	617.5	384.0	97.5	102.0	32.5	-	-	<0.001	100% Free Fibres	-	-	N
A18	A18	14.40	-	-	-	35.0	-	-	-	-	-	-	-	N
A19	A19	14.60	-	-	-	28.5	-	-	-	-	-	-	-	N

* These results are raw weighed data presented as per the Western Australian Guidelines and may be under the reporting limit for guidelines AS4964 of 0.1g/kg

Appendix 1: Soil Analysis Raw Data

Certificate Number: W1710160907
Report Date: 27 Oct 2017
Site Location: Otaki Railway



PRECISE

CONSULTING & LABORATORY

** Trace asbestos detected is indicative that freely liberated respirable fibres are present and dust control measures should be implemented or increased on site. This is not the sole indicator for the friable nature of the asbestos present.

*** Asbestos percentage is determined using EPA-600-R-93-116: Method for the Determination of Asbestos in Bulk Building Materials and are outside of IANZ accreditation #1097 and is therefore not endorsed by IANZ.



PRECISE

CONSULTING & LABORATORY

Report Date: 22 Jan 2018

Certificate Number: W1801171447.1

Tonkin and Taylor
Level 4, 2 Hunter Street, Wellington

Client Reference: 85985.007

Dear Chris Hillman,

Re: Asbestos Soil Identification Analysis – 85985.007

This report has been reissued as report editing. This report supersedes the previously issued report 'W1801171447'

21 sample(s) received on 17 Jan 2018 by Laura Liu.

The results of fibre analysis were performed by Laura Vitali of Precise Consulting and Laboratory Ltd on 18 Jan 2018.

The sample(s) were stated to be from 85985.007.

Sample analysis was performed using polarised light microscopy with dispersion staining in accordance with *AS4964-2004 Method for the qualitative identification of asbestos in soil samples*.

The results of the fibre analysis are presented in the appended table.

Should you require further information please contact Laura Vitali.

Yours sincerely

Laura Vitali
PRECISE LABORATORY IDENTIFIER

Sample Analysis Results

Certificate Number: W1801171447.1
Report Date: 22 Jan 2018
Site Location: 85985.007



PRECISE

CONSULTING & LABORATORY

Note 1: The reporting limit for this analysis is 0.1g/kg (0.01%) by application of polarised light microscopy, dispersion staining and trace analysis techniques.

Note 2: If mineral fibres of unknown type are detected (UMF), by PLM and dispersion staining, these may or may not be asbestos fibres. To confirm the identity of this fibre, another independent analytical technique such as XRD analysis is advised.

Note 3: The samples in this report are "As Received". The laboratory does not take responsibility for the sampling procedure or accuracy of sample location description. This document may not be reproduced except in full.

Identified by:

Approved Identifier: Laura Vitali

Reviewed by:

Key Technical Person: Laura Liu

Sample ID	Client Sample ID	Sample Location/Description/Dimensions	Analysis Results
S001	11.01	11.01 Non-Homogeneous Soil 43.5g	No Asbestos Detected Organic Fibres
S002	11.02	11.02 Non-Homogeneous Soil 197.0g	Chrysotile (white asbestos) Fibres Organic Fibres Amosite (brown asbestos) Fibres
S003	11.03	11.03 Non-Homogeneous Soil 418.0g	Chrysotile (white asbestos) Fibres Organic Fibres
S004	11.04	11.04 Non-Homogeneous Soil 154.0g	No Asbestos Detected Organic Fibres
S005	11.05	11.05 Non-Homogeneous Soil 102.5g	No Asbestos Detected Organic Fibres
S006	11.06	11.06 Non-Homogeneous Soil 109.5g	No Asbestos Detected Organic Fibres Synthetic Mineral Fibres
S007	11.07	11.07 Non-Homogeneous Soil 36.5g	No Asbestos Detected Organic Fibres
S008	11.08	11.08 Non-Homogeneous Soil 7.5g	No Asbestos Detected Organic Fibres Synthetic Mineral Fibres
S009	11.09	11.09 Non-Homogeneous Soil 22.5g	No Asbestos Detected Organic Fibres

Sample Analysis Results

Certificate Number: W1801171447.1
Report Date: 22 Jan 2018
Site Location: 85985.007



PRECISE

CONSULTING & LABORATORY

Sample ID	Client Sample ID	Sample Location/Description/Dimensions	Analysis Results
S010	11.10	11.10 Non-Homogeneous Soil 5.0g	No Asbestos Detected Organic Fibres
S011	11.11	11.11 Non-Homogeneous Soil 114.5g	No Asbestos Detected Organic Fibres Synthetic Mineral Fibres
S012	11.12	11.12 Non-Homogeneous Soil 167.0g	No Asbestos Detected Organic Fibres
S013	11.13	11.13 Non-Homogeneous Soil 74.5g	No Asbestos Detected Organic Fibres Synthetic Mineral Fibres
S014	11.14	11.14 Non-Homogeneous Soil 61.0g	No Asbestos Detected Organic Fibres Synthetic Mineral Fibres
S015	11.15	11.15 Non-Homogeneous Soil 291.0g	No Asbestos Detected Organic Fibres
S016	17.01	17.01 Non-Homogeneous Soil 1.0g	No Asbestos Detected Organic Fibres
S017	17.02	17.02 Non-Homogeneous Soil 67.0g	No Asbestos Detected Organic Fibres
S018	17.03	17.03 Non-Homogeneous Soil 6.0g	No Asbestos Detected Organic Fibres
S019	17.04	17.04 Non-Homogeneous Soil 48.0g	No Asbestos Detected Organic Fibres
S020	17.05	17.05 Non-Homogeneous Soil 26.0g	No Asbestos Detected Organic Fibres
S021	17.06	17.06 Non-Homogeneous Soil 14.0g	No Asbestos Detected Organic Fibres

Appendix 1: Soil Analysis Raw Data

Certificate Number: W1801171447.1

Report Date: 22 Jan 2018

Site Location: 85985.007



PRECISE

CONSULTING & LABORATORY

Sample ID	Client Sample ID	Sample Weights						>7mm Asbestos Containing Material (ACM)*		Asbestos Fines/Fibrous Asbestos*				Trace Asbestos Detected**
		Total 10L (Kg)	Total 500mL Sub-Sample (g)	>7mm Fraction (g)	2-7mm Fraction (g)	<2mm Sub Sample (g)	<2mm Excess (g)	>7mm ACM (g)	Form & %***	2-7mm ACM (g)	Form & %***	<2mm ACM (g)	Form & %***	
S001	11.01	14.45	43.5	No Fibrous Material Detected	22.0	21.5	-	N/A	N/A	No Asbestos Detected	N/A	No Asbestos Detected	N/A	No
S002	11.02	16.30	197.0	12.0	109.5	87.5	-	No Asbestos Detected	N/A	0.053; 0.002	Fibrous Material 80%; Free Fibres 100%	0.001	Free Fibres 100%	Yes
S003	11.03	16.40	418.0	No Fibrous Material Detected	264.0	102.5	51.5	N/A	N/A	0.175; <0.001	Fibrous Material 80%; Free Fibres 100%	0.004	Free Fibres 100%	Yes
S004	11.04	17.50	154.0	No Fibrous Material Detected	125.0	29.0	-	N/A	N/A	No Asbestos Detected	N/A	No Asbestos Detected	N/A	No
S005	11.05	14.90	102.5	No Fibrous Material Detected	60.5	42.0	-	N/A	N/A	No Asbestos Detected	N/A	No Asbestos Detected	N/A	No
S006	11.06	16.00	109.5	No Fibrous Material Detected	67.0	42.5	-	N/A	N/A	No Asbestos Detected	N/A	No Asbestos Detected	N/A	No
S007	11.07	14.80	36.5	No Fibrous Material Detected	14.5	22.0	-	-	-	No Asbestos Detected	N/A	No Asbestos Detected	N/A	No
S008	11.08	14.85	7.5	4.0	2.5	5.0	-	No Asbestos Detected	N/A	No Asbestos Detected	N/A	No Asbestos Detected	N/A	No
S009	11.09	-	22.5	No Fibrous Material Detected	15.0	7.5	-	N/A	N/A	No Asbestos Detected	N/A	No Asbestos Detected	N/A	No

Appendix 1: Soil Analysis Raw Data

Certificate Number: W1801171447.1
 Report Date: 22 Jan 2018
 Site Location: 85985.007



PRECISE
 CONSULTING & LABORATORY

Sample ID	Client Sample ID	Sample Weights						>7mm Asbestos Containing Material (ACM)*		Asbestos Fines/Fibrous Asbestos*				Trace Asbestos Detected**
		Total 10L (Kg)	Total 500mL Sub-Sample (g)	>7mm Fraction (g)	2-7mm Fraction (g)	<2mm Sub Sample (g)	<2mm Excess (g)	>7mm ACM (g)	Form & %***	2-7mm ACM (g)	Form & %***	<2mm ACM (g)	Form & %***	
S010	11.10	-	5.0	No Fibrous Material Detected	2.5	2.5	-	N/A	N/A	No Asbestos Detected	N/A	No Asbestos Detected	N/A	No
S011	11.11	17.55	114.5	No Fibrous Material Detected	54.5	60.0	-	N/A	N/A	No Asbestos Detected	N/A	No Asbestos Detected	N/A	No
S012	11.12	17.60	167.0	No Fibrous Material Detected	105.0	62.0	-	N/A	N/A	No Asbestos Detected	N/A	No Asbestos Detected	N/A	No
S013	11.13	16.95	74.5	No Fibrous Material Detected	39.5	35.0	-	N/A	N/A	No Asbestos Detected	N/A	No Asbestos Detected	N/A	No
S014	11.14	17.15	61.0	No Fibrous Material Detected	25.5	35.5	-	N/A	N/A	No Asbestos Detected	N/A	No Asbestos Detected	N/A	No
S015	11.15	17.40	291.0	No Fibrous Material Detected	223.5	67.5	-	N/A	N/A	No Asbestos Detected	N/A	No Asbestos Detected	N/A	No
S016	17.01	13.15	1.0	No Fibrous Material Detected	0.5	0.5	-	N/A	N/A	No Asbestos Detected	N/A	No Asbestos Detected	N/A	No
S017	17.02	-	67.0	No Fibrous Material Detected	37.0	30.0	-	N/A	N/A	No Asbestos Detected	N/A	No Asbestos Detected	N/A	No
S018	17.03	-	6.0	No Fibrous Material Detected	2.5	3.5	-	N/A	N/A	No Asbestos Detected	N/A	No Asbestos Detected	N/A	No
S019	17.04	16.30	48.0	No Fibrous Material Detected	20.0	28.0	-	N/A	N/A	No Asbestos Detected	N/A	No Asbestos Detected	N/A	No
S020	17.05	17.00	26.0	No Fibrous Material Detected	19.0	7.0	-	N/A	N/A	No Asbestos Detected	N/A	No Asbestos Detected	N/A	No

Appendix 1: Soil Analysis Raw Data

Certificate Number: W1801171447.1
 Report Date: 22 Jan 2018
 Site Location: 85985.007



PRECISE
 CONSULTING & LABORATORY

Sample ID	Client Sample ID	Sample Weights						>7mm Asbestos Containing Material (ACM)*		Asbestos Fines/Fibrous Asbestos*				Trace Asbestos Detected**
		Total 10L (Kg)	Total 500mL Sub-Sample (g)	>7mm Fraction (g)	2-7mm Fraction (g)	<2mm Sub Sample (g)	<2mm Excess (g)	>7mm ACM (g)	Form & %***	2-7mm ACM (g)	Form & %***	<2mm ACM (g)	Form & %***	
S021	17.06	13.35	14.0	No Fibrous Material Detected	10.5	3.5	-	N/A	N/A	No Asbestos Detected	N/A	No Asbestos Detected	N/A	No

* These results are raw weighed data presented as per the Western Australian Guidelines and may be under the reporting limit for guidelines AS4964 of 0.1g/kg

** Trace asbestos detected is indicative that freely liberated respirable fibres are present and dust control measures should be implemented or increased on site. This is not the sole indicator for the friable nature of the asbestos present.

*** Asbestos percentage is determined using EPA-600-R-93-116: Method for the Determination of Asbestos in Bulk Building Materials and are outside of IANZ accreditation #1097 and is therefore not endorsed by IANZ.



PRECISE

CONSULTING & LABORATORY

Report Date: 07 Nov 2017

Certificate Number: W1710201050

Tonkin + Taylor
Level 4, 2 Hunter Street, Wellington

Client Reference: 85985.007

Dear Natalie Pilcher,

Re: Asbestos Soil Identification Analysis – Otaki Railway

11 sample(s) received on 20 Oct 2017 by Karleen Glen.

The results of fibre analysis were performed by Laura Liu of Precise Consulting and Laboratory Ltd on 07 Nov 2017.

The sample(s) were stated to be from Otaki Railway.

Sample analysis was performed using polarised light microscopy with dispersion staining in accordance with *AS4964-2004 Method for the qualitative identification of asbestos in soil samples*.

The results of the fibre analysis are presented in the appended table.

Should you require further information please contact Laura Liu .

Yours sincerely

Laura Liu

PRECISE LABORATORY IDENTIFIER

Sample Analysis Results

Certificate Number: W1710201050
 Report Date: 07 Nov 2017
 Site Location: Otaki Railway



PRECISE
 CONSULTING & LABORATORY

Note 1: The reporting limit for this analysis is 0.1g/kg (0.01%) by application of polarised light microscopy, dispersion staining and trace analysis techniques.

Note 2: If mineral fibres of unknown type are detected (UMF), by PLM and dispersion staining, these may or may not be asbestos fibres. To confirm the identity of this fibre, another independent analytical technique such as XRD analysis is advised.

Note 3: The samples in this report are "As Received". The laboratory does not take responsibility for the sampling procedure or accuracy of sample location description. This document may not be reproduced except in full.

Identified by:

刘敏子

Reviewed by:

刘敏子

Approved Identifier: Laura Liu

Key Technical Person: Laura Liu

Sample ID	Client Sample ID	Sample Location/Description/Dimensions	Analysis Results
TP116 0.3	TP116 0.3	- Non-Homogeneous Soil 717.0g	Chrysotile (white asbestos) Fibres Organic Fibres Ballast
TP117 0.01	TP117 0.01	- Non-Homogeneous Soil 506.5g	No Asbestos Detected Organic Fibres Ballast
TP118 0.01	TP118 0.01	- Non-Homogeneous Soil 688.5g	No Asbestos Detected Organic Fibres Ballast
TP118 0.2	TP118 0.2	- Non-Homogeneous Soil 760.5g	No Asbestos Detected Organic Fibres Ballast
TP120 0.05	TP120 0.05	- Non-Homogeneous Soil 518.0g	No Asbestos Detected Organic Fibres Ballast
TP121 0.7	TP121 0.7	- Non-Homogeneous Soil 306.0g Fill	No Asbestos Detected Organic Fibres
TP122 0.9	TP122 0.9	- Non-Homogeneous Soil 425.5g Fill	Chrysotile (white asbestos) Fibres Organic Fibres
TP123 0.1	TP123 0.1	- Non-Homogeneous Soil 449.0g Topsoil	No Asbestos Detected Organic Fibres
TP124 0.02	TP124 0.02	- Non-Homogeneous Soil 522.0g Sub base	No Asbestos Detected Organic Fibres

Sample Analysis Results

Certificate Number: W1710201050
Report Date: 07 Nov 2017
Site Location: Otaki Railway



PRECISE

CONSULTING & LABORATORY

Sample ID	Client Sample ID	Sample Location/Description/Dimensions	Analysis Results
TP124 0.5	TP124 0.5	- Non-Homogeneous Soil Fill 322.0g	No Asbestos Detected Organic Fibres
TP125 0.0	TP125 0.0	- Non-Homogeneous Soil 599.0g	No Asbestos Detected Organic Fibres Ballast

Appendix 1: Soil Analysis Raw Data

Certificate Number: W1710201050
 Report Date: 07 Nov 2017
 Site Location: Otaki Railway



PRECISE
 CONSULTING & LABORATORY

Qualitative Results (IANZ)		Quantitative Results (non IANZ)																
		National Environment Protection (Assessment of Site Contamination) Measure (2013)																
Sample ID	Asbestos Fibre Type and ACM Type	Sample Weight (kg)	Total Sub-sample Weight (g)	ACM (>7mm) *				AF / FA (2 - 7mm) (100% ACM) *				AF / FA (<2mm) (100% ACM) *				<2mm Excess Sample Weight (g)	Trace Asbestos Detected **	Total Sample W/W %
				>7mm Fraction Sample Weight (g)	Weight of ACM (g)	Form %***	ACM (%)	2-7mm Fraction Sample Weight (g)	Weight of ACM (g)	Form %***	ACM (%)	<2mm Fraction Sample Weight (g)	Weight of AF/FA (g)	Form %***	AF / FA (%)			
TP116 0.3	CHR-ORG	-	717.0	325.0	-	-	-	144.0	<0.001	100% Free Fibres	-	103.5	<0.001	100% Free Fibres	-	144.5	Yes	-
TP117 0.01	NAD-ORG	15.20	506.5	-	-	-	-	110.5	-	-	-	102.0	-	-	-	294.0	No	-
TP118 0.01	NAD-ORG	14.75	688.5	210.5	-	-	-	105.5	-	-	-	-	-	-	-	-	No	-
TP118 0.2	NAD-ORG	-	760.5	261.5	-	-	-	191.5	-	-	-	104.5	-	-	-	203.5	No	-
TP120 0.05	NAD-ORG	-	518.0	216.5	-	-	-	118.5	-	-	-	99.0	-	-	-	84.0	No	-
TP121 0.7	NAD-ORG	-	306.0	-	-	-	-	3.0	-	-	-	102.0	-	-	-	195.5	No	-
TP122 0.9	CHR-ORG	-	425.5	194.0	-	-	-	57.5	-	-	-	96.5	<0.001	100% Free Fibres	-	77.5	Yes	-
TP123 0.1	NAD-ORG	-	449.0	219.5	-	-	-	33.5	-	-	-	99.5	-	-	-	33.5	No	-
TP124 0.02	NAD-ORG	14.50	522.0	-	-	-	-	208.0	-	-	-	95.0	-	-	-	219.0	No	-
TP124 0.5	NAD-ORG	-	322.0	-	-	-	-	-	-	-	-	105.5	-	-	-	217.5	No	-
TP125 0.0	NAD-ORG	16.00	599.0	136.5	-	-	-	145.5	-	-	-	100.5	-	-	-	216.5	No	-

Appendix 1: Soil Analysis Raw Data

Certificate Number: W1710201050
Report Date: 07 Nov 2017
Site Location: Otaki Railway



PRECISE

CONSULTING & LABORATORY

- * These results are raw weighed data presented as per the Western Australian Guidelines and may be under the reporting limit for guidelines AS4964 of 0.1g/kg
- ** Trace asbestos detected is indicative that freely liberated respirable fibres are present and dust control measures should be implemented or increased on site. This is not the sole indicator for the friable nature of the asbestos present.
- *** Asbestos percentage is determined using EPA-600-R-93-116: Method for the Determination of Asbestos in Bulk Building Materials and are outside of IANZ accreditation #1097 and is therefore not endorsed by IANZ.



PRECISE

CONSULTING & LABORATORY

Report Date: 03 Nov 2017

Certificate Number: W1710201035

Tonkin + Taylor
Level 4, 2 Hunter Street, Wellington

Client Reference: 85985.007

Dear Natalie Pilcher,

Re: Asbestos Soil Identification Analysis – Otaki Railway

4 sample(s) received on 20 Oct 2017 by Karleen Glen.

The results of fibre analysis were performed by Laura Liu of Precise Consulting and Laboratory Ltd on 03 Nov 2017.

The sample(s) were stated to be from Otaki Railway.

Sample analysis was performed using polarised light microscopy with dispersion staining in accordance with *AS4964-2004 Method for the qualitative identification of asbestos in soil samples*.

The results of the fibre analysis are presented in the appended table.

Should you require further information please contact Laura Liu .

Yours sincerely

Laura Liu

PRECISE LABORATORY IDENTIFIER

Sample Analysis Results

Certificate Number: W1710201035
Report Date: 03 Nov 2017
Site Location: Otaki Railway



PRECISE

CONSULTING & LABORATORY

Note 1: The reporting limit for this analysis is 0.1g/kg (0.01%) by application of polarised light microscopy, dispersion staining and trace analysis techniques.

Note 2: If mineral fibres of unknown type are detected (UMF), by PLM and dispersion staining, these may or may not be asbestos fibres. To confirm the identity of this fibre, another independent analytical technique such as XRD analysis is advised.

Note 3: The samples in this report are "As Received". The laboratory does not take responsibility for the sampling procedure or accuracy of sample location description. This document may not be reproduced except in full.

Identified by:

Reviewed by:

Approved Identifier: Laura Liu

Key Technical Person: Laura Liu

Sample ID	Client Sample ID	Sample Location/Description/Dimensions	Analysis Results
TP106 0.01	TP106 0.01	- Non-Homogeneous Soil 386.0g	Chrysotile (white asbestos) Fibres Organic Fibres
TP106 0.2	TP106 0.2	- Non-Homogeneous Soil 589.0g	Chrysotile (white asbestos) Fibres Organic Fibres
TP107 0.01	TP107 0.01	- Non-Homogeneous Soil 316.0g	No Asbestos Detected Organic Fibres
TP107 0.4	TP107 0.4	- Non-Homogeneous Soil 382.5g	No Asbestos Detected Organic Fibres

Appendix 1: Soil Analysis Raw Data

Certificate Number: W1710201035
 Report Date: 03 Nov 2017
 Site Location: Otaki Railway



PRECISE
 CONSULTING & LABORATORY

Sample ID	Client Sample ID	Sample Weights						>7mm Asbestos Containing Material (ACM)*		Asbestos Fines/Fibrous Asbestos*				Trace Asbestos Detected**
		Total 10L (Kg)	Total 500mL Sub-Sample (g)	>7mm Fraction (g)	2-7mm Fraction (g)	<2mm Sub Sample (g)	<2mm Excess (g)	>7mm ACM (g)	Form & %***	2-7mm ACM (g)	Form & %***	<2mm ACM (g)	Form & %***	
TP106 0.01	TP106 0.01	14.00	386.0	-	69.5	99.5	217.0	-	-	0.0325	40% Cement Sheet	-	-	Yes
TP106 0.2	TP106 0.2	14.95	589.0	-	132.5	106.5	350.0	9.5	40% Cement Sheet	0.0010	40% Cement Sheet	<0.001	40% Cement Sheet	Yes
TP107 0.01	TP107 0.01	14.90	316.0	-	51.5	99.5	164.0	-	-	-	-	-	-	No
TP107 0.4	TP107 0.4	11.90	382.5	-	6.0	101.0	273.5	-	-	-	-	-	-	No

* These results are raw weighed data presented as per the Western Australian Guidelines and may be under the reporting limit for guidelines AS4964 of 0.1g/kg

** Trace asbestos detected is indicative that freely liberated respirable fibres are present and dust control measures should be implemented or increased on site. This is not the sole indicator for the friable nature of the asbestos present.

*** Asbestos percentage is determined using EPA-600-R-93-116: Method for the Determination of Asbestos in Bulk Building Materials and are outside of IANZ accreditation #1097 and is therefore not endorsed by IANZ.



PRECISE

CONSULTING & LABORATORY

Report Date: 19 Dec 2017

Certificate Number: W1712120944

Tonkin and Taylor

105 Carlton Gore Road, Newmarket, Auckland

Client Reference: 859985.007

Dear Chris Hillman,

Re: Asbestos Soil Identification Analysis – 85985.007

17 sample(s) received on 11 Dec 2017 by Kristina Prokhanova.

The results of fibre analysis were performed by Laura Liu of Precise Consulting and Laboratory Ltd on 13 Dec 2017.

The sample(s) were stated to be from 85985.007.

Sample analysis was performed using polarised light microscopy with dispersion staining in accordance with *AS4964-2004 Method for the qualitative identification of asbestos in soil samples*.

The results of the fibre analysis are presented in the appended table.

Should you require further information please contact Laura Liu .

Yours sincerely

Laura Liu

PRECISE LABORATORY IDENTIFIER

Sample Analysis Results

Certificate Number: W1712120944
Report Date: 19 Dec 2017
Site Location: 85985.007



PRECISE

CONSULTING & LABORATORY

Note 1: The reporting limit for this analysis is 0.1g/kg (0.01%) by application of polarised light microscopy, dispersion staining and trace analysis techniques.

Note 2: If mineral fibres of unknown type are detected (UMF), by PLM and dispersion staining, these may or may not be asbestos fibres. To confirm the identity of this fibre, another independent analytical technique such as XRD analysis is advised.

Note 3: The samples in this report are "As Received". The laboratory does not take responsibility for the sampling procedure or accuracy of sample location description. This document may not be reproduced except in full.

Identified by:

Reviewed by:

Approved Identifier: Laura Liu

Key Technical Person: Laura Liu

Sample ID	Client Sample ID	Sample Location/Description/Dimensions	Analysis Results
200 0.1	200 0.1	85985.007 Non-Homogeneous Soil 556.0g	No Asbestos Detected Organic Fibres
201 0.1	201 0.1	85985.007 Non-Homogeneous Soil 421.5g	No Asbestos Detected Organic Fibres
203 0.1	203 0.1	85985.007 Non-Homogeneous Soil 361.0g	No Asbestos Detected Organic Fibres
204 0.1	204 0.1	85985.007 Non-Homogeneous Soil 360.0g	No Asbestos Detected Organic Fibres
205 0.1	205 0.1	85985.007 Non-Homogeneous Soil 287.0g	Chrysotile (white asbestos) Fibres Organic Fibres
206 0.1	206 0.1	85985.007 Non-Homogeneous Soil 317.0g	No Asbestos Detected Organic Fibres
207 0.1	207 0.1	85985.007 Non-Homogeneous Soil 339.5g	No Asbestos Detected Organic Fibres
209 0.1	209 0.1	85985.007 Non-Homogeneous Soil 331.0g	No Asbestos Detected Organic Fibres
210 0.1	210 0.1	85985.007 Non-Homogeneous Soil 344.5g	No Asbestos Detected Organic Fibres

Sample Analysis Results

Certificate Number: W1712120944
Report Date: 19 Dec 2017
Site Location: 85985.007



PRECISE

CONSULTING & LABORATORY

Sample ID	Client Sample ID	Sample Location/Description/Dimensions	Analysis Results
211 0.1	211 0.1	85985.007 Non-Homogeneous Soil 407.0g	No Asbestos Detected Organic Fibres
218 N 1	218 N 1	85985.007 Non-Homogeneous Soil 318.5g	No Asbestos Detected Organic Fibres
212 0.1	212 0.1	85985.007 Non-Homogeneous Soil 470.0g	No Asbestos Detected Organic Fibres
214 N 1	214 N1	85985.007 Non-Homogeneous Soil 391.0g	No Asbestos Detected Organic Fibres
214 S 1	214 S 1	85985.007 Non-Homogeneous Soil 267.5g	No Asbestos Detected Organic Fibres
215 W 1	215 W 1	85985.007 Non-Homogeneous Soil 440.0g	No Asbestos Detected Organic Fibres
215 E 1	215 E 1	85985.007 Non-Homogeneous Soil 427.5g	No Asbestos Detected Organic Fibres
217 E 1	217 E 1	85985.007 Non-Homogeneous Soil 389.5g	No Asbestos Detected Organic Fibres

Appendix 1: Soil Analysis Raw Data

Certificate Number: W1712120944
 Report Date: 19 Dec 2017
 Site Location: 85985.007



PRECISE
 CONSULTING & LABORATORY

Sample ID	Client Sample ID	Sample Weights						>7mm Asbestos Containing Material (ACM)*		Asbestos Fines/Fibrous Asbestos*				Trace Asbestos Detected**
		Total 10L (Kg)	Total 500mL Sub-Sample (g)	>7mm Fraction (g)	2-7mm Fraction (g)	<2mm Sub Sample (g)	<2mm Excess (g)	>7mm ACM (g)	Form & %***	2-7mm ACM (g)	Form & %***	<2mm ACM (g)	Form & %***	
200 0.1	200 0.1	11.4	556.0	-	29.0	99.5	427.5	-	-	-	-	-	-	No
201 0.1	201 0.1	10.0	421.5	-	77.0	100.5	243.5	-	-	-	-	-	-	No
203 0.1	203 0.1	8.30	361.0	-	42.0	105.5	213.5	-	-	-	-	-	-	No
204 0.1	204 0.1	12.3	360.0	-	120.5	101.5	137.5	-	-	-	-	-	-	No
205 0.1	205 0.1	7.4	287.0	-	18.5	99.5	169.0	-	-	-	-	<0.001	-	Yes
206 0.1	206 0.1	8.1	317.0	-	17.0	100.0	200.0	-	-	-	-	-	-	No
207 0.1	207 0.1	9.25	339.5	-	36.5	106.5	196.5	-	-	-	-	-	-	No
209 0.1	209 0.1	12.45	331.0	-	9.5	97.5	225.0	-	-	-	-	-	-	No
210 0.1	210 0.1	9.5	344.5	-	58.0	93.5	192.0	-	-	-	-	-	-	No
211 0.1	211 0.1	11.5	407.0	-	35.0	97.0	275.5	-	-	-	-	-	-	No
218 N 1	218 N 1	11.15	318.5	-	13.5	101.0	263.0	-	-	-	-	-	-	No
212 0.1	212 0.1	10.3	470.0	-	115.5	101.5	253.0	-	-	-	-	-	-	No
214 N 1	214 N1	9.5	391.0	-	27.0	100.0	265.0	-	-	-	-	-	-	No
214 S 1	214 S 1	8.1	267.5	-	49.0	99.0	109.0	-	-	-	-	-	-	No
215 W 1	215 W 1	9.1	440.0	-	47.0	104.0	289.0	-	-	-	-	-	-	No

Appendix 1: Soil Analysis Raw Data

Certificate Number: W1712120944
 Report Date: 19 Dec 2017
 Site Location: 85985.007



PRECISE
 CONSULTING & LABORATORY

Sample ID	Client Sample ID	Sample Weights						>7mm Asbestos Containing Material (ACM)*		Asbestos Fines/Fibrous Asbestos*				Trace Asbestos Detected**
		Total 10L (Kg)	Total 500mL Sub-Sample (g)	>7mm Fraction (g)	2-7mm Fraction (g)	<2mm Sub Sample (g)	<2mm Excess (g)	>7mm ACM (g)	Form & %***	2-7mm ACM (g)	Form & %***	<2mm ACM (g)	Form & %***	
215 E 1	215 E 1	9.6	427.5	1.5	70.5	104.0	251.0	-	-	-	-	-	-	No
217 E 1	217 E 1	11.45	389.5	-	17.5	100.0	272.5	-	-	-	-	-	-	No

* These results are raw weighed data presented as per the Western Australian Guidelines and may be under the reporting limit for guidelines AS4964 of 0.1g/kg

** Trace asbestos detected is indicative that freely liberated respirable fibres are present and dust control measures should be implemented or increased on site. This is not the sole indicator for the friable nature of the asbestos present.

*** Asbestos percentage is determined using EPA-600-R-93-116: Method for the Determination of Asbestos in Bulk Building Materials and are outside of IANZ accreditation #1097 and is therefore not endorsed by IANZ.



ANALYSIS REPORT

Client:	Tonkin & Taylor	Lab No:	1852146	A2Pv1
Contact:	C Hillman C/- Tonkin & Taylor PO Box 2083 Wellington 6140	Date Received:	29-Sep-2017	
		Date Reported:	29-Sep-2017	
		Quote No:	73495	
		Order No:	28985.007	
		Client Reference:	28985.007	
		Add. Client Ref:	Sampled:27/09/17	
		Submitted By:	Cherise Martin	

Sample Type: Building Material

Sample Name	Lab Number	Sample Category	Sample Weight on receipt	Asbestos Presence / Absence
A	1852146.1	Fibre Cement	22.03	Asbestos NOT detected.
B	1852146.2	Fibre Cement	24.34	Amosite (Brown Asbestos) and Chrysotile (White Asbestos) detected.
C	1852146.3	Fibre Cement	35.20	Asbestos NOT detected.
D	1852146.4	Fibre Cement	8.20	Asbestos NOT detected.
Z	1852146.5	Fibre Cement	136.12	Chrysotile (White Asbestos) detected.

SUMMARY OF METHODS

The following table(s) gives a brief description of the methods used to conduct the analyses for this job. The detection limits given below are those attainable in a relatively clean matrix. Detection limits may be higher for individual samples should insufficient sample be available, or if the matrix requires that dilutions be performed during analysis.

Sample Type: Building Material

Test	Method Description	Default Detection Limit	Sample No
Asbestos in Bulk Material			
Sample Category	Assessment of sample type. Analysed at Hill Laboratories - Asbestos; 72 Grafton Road, Auckland.	-	1-5
Sample Weight on receipt	Sample weight. Analysed at Hill Laboratories - Asbestos; 72 Grafton Road, Auckland.	0.01 g	1-5
Asbestos Presence / Absence	Examination using Low Powered Stereomicroscopy followed by 'Polarised Light Microscopy' including 'Dispersion Staining Techniques'. Analysed at Hill Laboratories - Asbestos; 72 Grafton Road, Auckland. AS 4964 (2004) - Method for the Qualitative Identification of Asbestos in Bulk Samples.	-	1-5

These samples were collected by yourselves (or your agent) and analysed as received at the laboratory.

Samples are held at the laboratory after reporting for a length of time depending on the preservation used and the stability of the analytes being tested. Once the storage period is completed the samples are discarded unless otherwise advised by the client.

This report must not be reproduced, except in full, without the written consent of the signatory.

Ian Murgatroyd BSc
Auckland Branch Manager





PRECISE

CONSULTING & LABORATORY

Report Date: 09 Jan 2018

Certificate Number: B1801091049

Tonkin and Taylor

105 Carlton Gore Road, Newmarket, Auckland

Client Reference: 85985.007

Dear Chris Hillman and Natalie Pilcher,

Re: Asbestos Identification Analysis – 85985.007

2 sample(s) received on 21 Dec 2017 by Laura Vitali.

The results of fibre analysis were performed by Laura Vitali of Precise Consulting and Laboratory Ltd on 09 Jan 2018.

The sample(s) were stated to be from 85985.007.

Sample analysis was performed using polarised light microscopy with dispersion staining in accordance with the guidelines of *AS4964-2004 Method for the qualitative identification of asbestos in bulk samples*.

The results of the fibre analysis are presented in the appended table.

Should you require further information please contact Laura Vitali.

Yours sincerely

Laura Vitali

PRECISE LABORATORY IDENTIFIER

Sample Analysis Results

Certificate Number: B1801091049
Report Date: 09 Jan 2018
Site Location: 85985.007



PRECISE

CONSULTING & LABORATORY

Note 1: The reporting limit for this analysis is 0.1g/kg (0.01%) by application of polarised light microscopy, dispersion staining and trace analysis techniques.

Note 2: If mineral fibres of unknown type are detected (UMF), by PLM and dispersion staining, these may or may not be asbestos fibres. To confirm the identity of this fibre, another independent analytical technique such as XRD analysis is advised.

Note 3: The samples in this report are "As Received". The laboratory does not take responsibility for the sampling procedure or accuracy of sample location description. This document may not be reproduced except in full.

Identified by:

Reviewed by:

Approved Identifier: Laura Vitali

Key Technical Person: Chris Mills

Sample ID	Client Sample ID	Sample Location/Description/Dimensions	Analysis Results
S001	AA	Rahui Rd, material found on surface of ground Insulation material L1 - Debris; L2 - Insulation; 90 x 120 x 5 mm	No Asbestos Detected Organic Fibres Synthetic Mineral Fibres
S002	BB	Rahui Rd, material found on surface of ground Insulation material L1 - Debris; L2 - Insulation; 146 x 123 x 8 mm	No Asbestos Detected Organic Fibres Synthetic Mineral Fibres