

**To** Rob Montgomery  
Manager Road Compliance

**From** Nathan Murrell  
Commercial Transport Officer

**Date** 20<sup>th</sup> February 2019

**Subject** **Pacific Haulage Limited**  
s18(c)(i)  
s18(c)(i)

---

A desktop review of Pacific Haulage Limited is completed and the following is a summary of my findings with my recommendation.

(1) **TSL Information**

**Name:** Pacific Haulage Limited

**Address:** 107 Aerodrome Road, Matawhero, Gisborne 4071

**Director/COKLP:** Calvin John Paddon

(2) **NZ Companies Office**

**Directors:** Calvin John Paddon & Warwick Kenneth Wilshier

**Shareholdings:** Calvin John Paddon, s9(2)(a) Wilshier Management Limited

(3) **Previous History**

**09.11.12** - ION issued for "Not up to COF Standard" as part of s6(c)

**28.05.13** - ORS visit made 27.02.13 and information given out.

**11.12.13** - ION issued for "Not up to COF Standard" as part of s6(c)

**02.05.14** - Relationship visit made to discuss TOH with individual drivers in conjunction with CVST.

Issues discussed around safety of fleet drivers.

**02.09.14** - Updated company with WIM data and discussed lack of work.

(4) **Traffic Offence History & Demerit Points**

- **Company:** Last 2 years 9 x Not up to COF Standard, 4 x Exceeds Maximum Gross Mass Limits, 3 x Excess Speed, 1 x Wheel Not Securely Attached to Hub, 1 x Exceed Mass On 2 Axles in Tandem Set - HPMV,  
1 x Failed to Comply with HPMV Permit Conditions - Mass, 1 x Inadequate Mudguards Twin Tyred Rear Axle, 1 x Operate Overlength Towing Vehicle, 1 x Unsafe Loading, 1 x Operated a Vehicle With Damaged Tyre, 1 x Overdimension Vehicle Breached Requirements
- **Persons in control:** s9(2)(a)

(5) Criminal History

A criminal history report for the company shows only historic charges dating back from 1993.

(6) Vehicle Standards:

COF Pass rate:		94%	84.7%
CoF Faults Per Failed Vehicle (FPFV):		1.26	3.2
COF Average faults on all inspections:		0.07	3.0
Total number of COF inspections:		340	
Total number of COF faults:		24	
Total Passes:		321	
Total Fails:		19	
RID pass rate:		56%	82.9%
RID Faults Per Failed Vehicle (FPFV):		1.4	1.3
RID Average faults on all inspections:		0.6	0.2
Total number of RID inspections:		103	
Total Number of Vehicles Inspected:		184	
Total number of RID faults:		111	
TOTAL NUMBER OF PINK STICKER FAULTS:		15% / 27	
TOTAL NUMBER OF GREEN STICKER FAULTS:		8% / 15	
TOTAL NUMBER OF G2 FAULTS:		21% / 39	
TOTAL NUMBER OF VEHICLE PASSES:		56% / 103	
Total number of vehicles in fleet:		97	
Average age of trucks:		6.57 Years	
Average age of trailers:		6.75 Years	
Average age of fleet:		6.66Years	

Main COF Faults:	% of all faults and number of faults
BRAKES	59% / 13
SUSPENSION	14% / 3
EXTERIOR	9% / 2
CHASSIS	9% / 2
TOWING	5% / 1
AIR SYSTEM	5% / 1
Main Roadside faults:	% of all faults and number of faults
LIGHTING	47% / 52
BRAKES	22% / 24
WHEELS AND TYRES	9% / 10
SUSPENSION	6% / 7
MOTIVE	5% / 6
EXTERIOR	7% / 8
TOWING	2% / 2
VEHICLE	2% / 2

Hyperion "First Failed COF" analysis was completed for a period of two years between 28/02/2017 and 27/02/2019 which included 97 heavy goods vehicles operated by Pacific Haulage Limited. A roadside inspection report was also completed for the same period which includes 184 vehicles in 103 inspections. The summary of the results is appended below.

**Pre- visit, file review (COF and RID reports) comments:**

Noting the percentage difference between the COF pass rate and the RID pass rate it appears that the company carried out Vehicle Condition Assessments prior to presenting vehicles for a COF. Alternatively, drivers are not undertaking walkaround checks and not reporting faults which can reduce the operator's ability to maintain the vehicles to COF standards.

On eighteen occasions, sixteen vehicles were presented for COF inspections with expired COF's, where they were expired by either 354 days, 109 days, 74 days, 59 days, 54 days, 20 days, 17 days, 11 days, 8 days, 6days, 5 days, 4 days, 3 days and 1 day. Any vehicle under 5 days may not have been used and may have been getting repairs to prepare for the COF inspection. Others at the high end, may have been parked up or could have had crash damage or other major repairs required. At the time of a meeting this topic will need to be covered to insure vehicle aren't being used with expired COF's.

- Although the above summary confirms the fleet COF pass rate is above the current national average, the roadside inspection pass rate is 56% showing an issue between COF's and service inspections. Lack of monitoring or maintenance systems along with daily walkaround checks could be the main contributing factors.
- The highest number of roadside faults identified was lighting at 47%, made up of 52 faults which relates to any walkaround check system having gaps.

- The most number of faults identified at COF inspections were brakes which indicates safety issues relating to brake components. The most common fault with brakes in, brake imbalance (match), with are approximately two occasions noted for the brakes need to improve.
- The above information indicates that the operator has scope to improve systems to better monitor and maintain the vehicle fleet to "Fit and Proper" status as required by Land Transport Act 1998: (Section 30A (1) (a)).
- All other information is contained in the graphs above.

(7) **Debt to the Agency:** No outstanding debt with NZTA

(8) **Debt to Ministry of Justice:** No outstanding debt disclosed.

(9) **RUC Issues:** NO RUC offences have been identified.

(10) **Other criminal/traffic offences that require further investigation, include SOF:** None identified.

(11) **Permits:** The last two year TOH shows two offences for one overweight vehicle – a breach of a tandem axle mass limit which incurs a breach of the HPMV permit also. Another vehicle was the subject of an overdimension permit breach within this period.

(12) **Complaints:** No complaint's recorded or received.

s9(2)(ba)(i)

A large black rectangular redaction box covers the majority of the page content between the (12) Complaints section and the (14) Recommendation section.

(14) **Recommendation:**

The operator has an issue with maintenance which is reflected by the large gap between COF and Roadside inspections. I would suggest a visit is needed to address this gap in maintenance standards. Current systems should be checked and adjusted to increase the auditing and effectiveness of walkaround checks to reduce faults like lighting and tyre faults. This will help improve the poor RID pass rate which is 56%.

Nathan Murrell

**Commercial Transport Officer**

To Anna Reed  
Commercial Transport Advisor

From Nathan Murrell  
Commercial Transport Officer

Date 1<sup>st</sup> August 2019

Subject Pacific Haulage Limited

s18(c)(i)

s18(c)(i)

---

ROADSIDE OPERATION

s6(c)

It was very pleasing to see that overall the faults located were mostly of a minor nature i.e. lighting faults. Only one vehicle was parked roadside to replace two tyres, one of which was fully deflated and coming off the rim, causing the other tyre to begin "unzipping" along the side wall due to the added weight on the single tyre.

MEETING WITH PACIFIC HAULAGE LIMITED

At 9.00am on Thursday the 25<sup>th</sup> July 2019, Wendy Bryant and I attended a meeting at the offices of Pacific Haulage Limited with s9(2)(a)

Over the course of the four-hour meeting we discussed several issues that had come to light as a result of the analysis from the audit records. Also discussed was the request for drug testing records and a review of their testing regime.

s9(2)(a) explained that he had only moved to Gisborne in s9(2)(a) and it was his role to improve compliance for the company. This coincided with the time that the audit was commenced by NZTA.

In his time with the company he has been actively reviewing their compliance activities and looking for ways to make improvements. This will be easier to manage with the merger of the two companies about to occur before any major improvements are made, however he has been proactively looking at and implementing changes already.

As we discussed topics with him, he was able to advise us of work he had already undertaken to address each issue, or upcoming changes that he was implementing. Where we discussed topics that he was not aware of, he was very willing to take note, listen to our ideas and take onboard any suggestions that we had.

#### MATTERS DISCUSSED

- Driver offences – although stated in their contracts, drivers have not been informing PHL management when they have incurred personal infringements i.e. seatbelt or speeding, while in control of company vehicles. s9(2)(a) stated that this is not unusual in any company. I advised him that I have recommended to CVST that they put full notes in the “Driver Notes” field of CVIRs detailing the offence – this should make it easier for him to identify offences when he received the CVIRs. This won’t work if stopped by general Police staff, however this would be a rare occurrence.
- s9(2)(a) was not receiving CVIR and TORO reports and alerts, as they were going to the generic s9(2)(a) email address and just being filed by office staff. He had already ensured that both alerts are automatically forwarded to his work email address so that he can record and follow up on these issues with the workshop or individual drivers where necessary.
- Driver speeding and logbooks – a logbook checking system had just been implemented when we first met with PHL in March 2019. This is continuing and showing a pattern of improvements with less errors and omissions occurring. Clear notes are made showing what issues were identified and what discussions took place with drivers. This was evident in the roadside checks where there were very few logbook issues located. Alongside this they are running regular reports for speed alerts and these are being analysed and discussed with the relevant drivers.
- To bring about change in driver behavior the company has implemented a driver bonus scheme which is awarded quarterly to the top driver for Truck Condition, Overspeeds, Incident Reporting and Most Co-operative. s9(2)(a) says there is evidence already that this has reduced overspeed events, incident reporting has increased so they are more aware of any areas of risk requiring attention, vehicles are being kept in better condition overall. This is being driven by friendly rivalry between staff and they are each holding others to account if they see anything requiring attention.
- Drivers are now attending Saturday morning training in the workshop, in groups of 4-5, with the lead mechanic taking them over safety checks and basic maintenance. This should assist in daily pre-departure checks being more thorough and reduce the number of roadside defects located.
- Although new logbooks have been issued with a single tick box and signoff for drivers to say they have carried out a pre-deployment check, which is an improvement, they still had not introduced a full checklist for drivers to use itemizing all areas to be checked. s9(2)(a) agreed that a full check

list is the best way to manage daily pre-deployment checks, and that he is working further to implement this, which is likely to be in an electronic format along with improvements due later in the year.

- Improvements have been made with maintenance records, with detailed records kept of all repairs and servicing for individual vehicles instead of relying on invoicing alone as proof of repairs. The records also record who undertook the repairs and timelines so where issues arise there is some accountability that can be measured and improved if required.
- Previously the fleet underwent weekly "greasing" services, which with a combined fleet of over 70 truck and trailer units was a huge strain on the workshop capacity and the logistics of having to swap vehicles so that drivers could continue operating. This has been reduced to fortnightly checks, but this has allowed the workshop to commit more time to undertake more thorough safety-based checks on each unit, and therefore should reduce the number of roadside defects.
- Along with the fortnightly check each unit will be put through a brake check with the onsite roller-brake machine. This was only performed at a full service previously which may only be 2-3 monthly. This should reduce any incidence of roadside failures for stroked out brake adjusters and ensure that the fleet is up to a roadworthy standard for brake performance at all times.
- The company is actively recruiting for a suitably qualified person to be employed full time as a driver trainer. This is so they can carry out regular driving assessments of the current drivers and where needed then remedial training can take place. The trainers focus will also be on drivers who are regularly being spoken to about logbook breaches and are appearing on overspeed reports.
- They are also actively taking part in recruitment open days at schools and field day events and currently have a couple of students who are undertaking ride-alongs with drivers with a view to taking up employment. They would also like to make further use of Accelerated Licensing Program to bring through new drivers.
- Drug testing - s9(2)(a) explained that the drug testing regime is part of a local industry initiative which is one of the first of its kind in the country. The company undertake five random drug tests per month with names generated by software. Tests are undertaken on site by a trained member of staff and all results must be recorded and forwarded to the Eastland Wood Council who have overall control of the program. Any positive onsite results are sent to a lab for analysis and confirmation of the result. Any staff with Class A positive outcomes are dismissed immediately. Any other positive tests result in the driver being offered a rehab program through the Eastland Wood Council. Most of the local companies are on this program, and all information is shared so that drivers with positive results can't just swap companies and continue driving. Eastland Wood Council also undertake random, monthly onsite testing at skid sites and the port, where the whole site can be closed down and all persons including truck drivers present must be tested.
- One of the biggest changes to come is the merging of both fleets into one operational model. This will see the removal of cell phones from company vehicles to be replaced by a full Navman GPS and

telemetry system for both fleet monitoring and dispatch systems. This should allow the company to increase efficiency across both fleets, but also to introduce integrated new systems for vehicle pre-departure checks, management of fleet overspeed events, and they will also be looking to integrate an electronic logbook system at a later date. The initial system is due to be implemented on the 1<sup>st</sup> September 2019 and will require considerable training and time to bed in and see date and results. s9(2)(a) anticipate the biggest difficulty will come with the driver culture and getting them to accept and embrace this change.

Following this meeting I have had regular contact with s9(2)(a) following up on results from the roadside audit, running ideas past me in regard to ideas for training purposes and this has allowed us to build on the working relationship.

At the time the audit began the companies RID pass rate was only 54%. Prior to the roadside operation the company had already shown and improvements to 62%, and following the roadside operation this is now standing at 65%.

During the course of the meeting it became clear that s9(2)(a) had a very good grasp of the issues that PHL faced and had already made a lot of progress in putting the right systems and processes in place to ensure that the company improve their RID and COF pass rates. This is evident by the increasing RID pass rates.

Any extra information that we have provided has been taken onboard and s9(2)(a) has shown that he has a proactive manner in contacting the agency further for assistance, and we now have a good open working relationship with a key member of the PHL team.

Both Wendy & I were impressed with what we saw and discussed and believe that with s9(2)(a) leading the proposed changes that the company is heading in the right direction.

#### RECOMMENDATION

We therefore both recommend that the company is left to implement the changes and a 3-monthly monitoring regime is put in place to ensure that the improvements are continued to be made. This will be monitored by RID and COF reports and we will also check company and driver infringement offences to ensure these are also being managed correctly.

It is anticipated that it will take a minimum of 12 months to show any significant results, at which time we can make further analysis and recommendations on continued monitoring.

Nathan Murrell  
**Commercial Transport Officer**





## Vehicle Specialist Report Operator Review

(for use by Vehicle Specialists only)

TSL number:	s18(c)(i)
Date and time of visit:	?????????
Operator's name:	Pacific Haulage Limited
Operator's address:	107 Aerodrome Road, Matawhero, Gisborne
Contact name:	s9(2)(a)
Contact details:	s9(2)(a)
Operator type:	GOODS SERVICE
Industry/vehicle type:	LOGGING
Vehicle Specialist:	NEIL McALPINE

Vehicle Data	Previous Results Date:	Current Results Date: 01/2019 & 28/02 / 2019	National Average Date:
ORS Star Rating and Score:			
COF Pass rate:		94%	84.7%
CoF Faults Per Failed Vehicle (FPFV):		1.26	3.2
COF Average faults on all inspections:		0.07	3.0
Total number of COF inspections:		340	
Total number of COF faults:		24	
Total Passes:		321	
Total Fails:		19	
RID pass rate:		56%	82.9%
RID Faults Per Failed Vehicle (FPFV):		1.4	1.3
RID Average faults on all inspections:		0.6	0.2
Total number of RID inspections:		103	
Total Number of Vehicles Inspected:		184	
Total number of RID faults:		111	

TOTAL NUMBER OF PINK STICKER FAULTS:		15% / 27	
TOTAL NUMBER OF GREEN STICKER FAULTS:		8% / 15	
TOTAL NUMBER OF G2 FAULTS:		21% / 39	
TOTAL NUMBER OF VEHICLE PASSES:		56% / 103	
Total number of vehicles in fleet:		97	
Average age of trucks:		6.57 Years	
Average age of trailers:		6.75 Years	
Average age of fleet:		6.66Years	
<b>Main COF Faults:</b>	<b>% of all faults and number of faults</b>		
BRAKES		59% / 13	
SUSPENSION		14% / 3	
EXTERIOR		9% / 2	
CHASSIS		9% / 2	
TOWING		5% / 1	
AIR SYSTEM		5% / 1	
<b>Main Roadside faults:</b>	<b>% of all faults and number of faults</b>		
LIGHTING		47% / 52	
BRAKES		22% / 24	
WHEELS AND TYRES		9% / 10	
SUSPENSION		6% / 7	
MOTIVE		5% / 6	
EXTERIOR		7% / 8	
TOWING		2% / 2	
VEHICLE		2% / 2	
Hyperion reports discussed:	Yes	No	
Are driver walk around checks carried out/recorded?	Yes	No	
Can you explain the company's procedure for preparing vehicles for a CoF? Who undertakes this and are there records and schedules in place?	Yes	No	

Who carries out the regular servicing of the company vehicles and at what intervals? How does the company monitor these services?	Yes	No
Is there a method to alert the operator of the expiry date of critical safety components? i.e. drawbars, draw beams etc. Expired components list produced	Yes	No
Are there fifth wheel components in the fleet? If so who services/maintains them?	Yes	No
Are brake adjustments, greasing, minor service etc carried out between major service intervals? How often and by whom?	Yes	No
Are maintenance schedules / service records available? a. For trucks?      b. For trailers?	Yes	No
If maintenance/servicing is conducted in-house, is there a formal training programme from workshop staff?	Yes	No
Is there evidence to confirm vehicles are maintained to COF standards at all times?	Yes	No
Is there evidence of vehicles being operated without COFs or following the failure of a COF?	Yes	No
Are there any negative RID events and/or crashes.	Yes	No
Does the operator receive RID reports via e-mail?	Yes	No
Does the Operator have a formal Policy around wheel end re-torqueing?	Yes	No

Released under the Official Information Act 1982

Does the Operator know what their Service Provider gives them for an A and B service?	Yes	No
Are there over dimension vehicles in the fleet? a. 50MAX b. HPMV's c. Over Dimension	Yes	No
Does the Operator have a process for provision and maintenance of safe vehicles? a. Is there a process for receiving information about Hazards, risks and incidents in vehicles b. Is there evidence the Operator responds to that information received? c. Is the process being used?	Yes	No
<p><b>Pre visit, file review (COF and RID reports) comments:</b></p> <p>Noting the percentage different between the COF pass rate and the RID pass rate it appears that the company carried out Vehicle Condition Assessments prior to presenting vehicles for a COF or with driver not undertaking walkaround check and not reporting faults this can reduce the operator's ability to maintain the vehicles to COF standard at all times.</p>		
<p><b>Other Issues discussed:</b></p>		

Released under the Official Information Act 1982

**Recommendations to Vehicle Specialist:**

Signed:

Date:

Released under the Official Information Act 1982

Vehicles Presented for CoF by TSL Number

TSL Holder Company  
Or Surname:

PACIFIC HAULAGE LIMITED

TSL Number:

s18(c)(i)

First Name:

Middle Names:

Out of scope

PACIFIC HAULAGE LIMITED

Plate	Vehicle Make	Vehicle Model	CoF Date	Result
R443P	KRAFT	404	01/03/2017	PASS
PHL30	KENWORTH	K	01/03/2017	PASS
PHL20	KENWORTH	K108	06/03/2017	PASS
T674A	KRAFT	404	06/03/2017	PASS
Z745L	KRAFT	404	08/03/2017	PASS
PHL09	KENWORTH	T	08/03/2017	PASS
PHL21	KENWORTH	T	15/03/2017	PASS
U800M	KRAFT	404	15/03/2017	PASS
W730M	KRAFT	404	22/03/2017	FAIL
PHL33	KENWORTH	T	22/03/2017	PASS
W730M	KRAFT	404	22/03/2017	PASS
AYC954	MINISUBISHI	CANTER	29/03/2017	PASS
K239N	KRAFT	404	29/03/2017	PASS
LCL769	KENWORTH	T	29/03/2017	PASS
PHL36	KENWORTH	T	31/03/2017	PASS
PHL27	KENWORTH	T	03/04/2017	PASS
5W717	KRAFT	400	03/04/2017	PASS
R177T	KRAFT	404	05/04/2017	PASS
PHL02	KENWORTH	K108	05/04/2017	PASS
K898F	KRAFT	400	10/04/2017	PASS
PHL05	KENWORTH	T	10/04/2017	PASS

Plate	Vehicle Make	Vehicle Model	CoF Date	Result
Z760L	KRAFT	404	12/04/2017	PASS
PHL01	KENWORTH	T	12/04/2017	PASS
LUM43	KENWORTH	T	19/04/2017	PASS
PHL23	KENWORTH	T408	24/04/2017	PASS
Q884L	KRAFT	404	24/04/2017	PASS
S597H	KRAFT	404	26/04/2017	PASS
PHL19	KENWORTH	K	26/04/2017	PASS
7B837	KRAFT	400	28/04/2017	PASS
LGC224	KENWORTH	K104	01/05/2017	PASS
K438A	KRAFT	404	01/05/2017	PASS
K436A	KRAFT	404	03/05/2017	PASS
LHM253	KENWORTH	K104	03/05/2017	PASS
PHL35	KENWORTH	T	08/05/2017	PASS
T672A	KRAFT	400	08/05/2017	PASS
7K728	KRAFT	400	21/06/2017	PASS
7P447	KRAFT	400	12/07/2017	PASS
8A839	KRAFT	404	19/09/2017	PASS
7U983	KRAFT	404	26/09/2017	PASS
7K728	KRAFT	400	22/11/2017	PASS
8K642	KRAFT	404	29/11/2017	PASS
7P447	KRAFT	400	08/12/2017	PASS
9C103	KRAFT	505	05/02/2018	PASS
7U983	KRAFT	404	05/03/2018	PASS
8A839	KRAFT	404	12/03/2018	PASS
7K728	KRAFT	400	09/05/2018	PASS
8K642	KRAFT	404	21/05/2018	PASS
9Z506	KRAFT	507	18/06/2018	PASS
7P447	KRAFT	400	27/06/2018	PASS
9Z511	KRAFT	505	13/07/2018	PASS
9Z516	KRAFT	505	24/07/2018	PASS
9C103	KRAFT	505	25/07/2018	PASS
13Q38	KRAFT	505	23/08/2018	PASS
8A839	KRAFT	404	10/09/2018	PASS
7U983	KRAFT	404	24/09/2018	PASS
9Z506	KRAFT	507	12/11/2018	PASS
7K728	KRAFT	400	19/11/2018	PASS
8K642	KRAFT	404	26/11/2018	PASS
21J19	KRAFT	505	28/11/2018	PASS
7P447	KRAFT	400	03/12/2018	PASS
21J26	KRAFT	505	12/12/2018	PASS
9Z511	KRAFT	505	12/12/2018	PASS
9Z516	KRAFT	505	03/01/2019	PASS
9C103	KRAFT	505	04/01/2019	PASS
13Q38	KRAFT	505	07/01/2019	PASS

PACIFIC HAULAGE LTD

Plate	Vehicle Make	Vehicle Model	CoF Date	Result
6Y910	KRAFT	400	31/03/2017	PASS
M829A	KRAFT	404	19/04/2017	PASS

Plate	Vehicle Make	Vehicle Model	CoF Date	Result
PHL25	KENWORTH	T	02/05/2017	PASS
PHL06	KENWORTH	T	10/05/2017	PASS
Z505Y	KRAFT	404	10/05/2017	PASS
N102T	KRAFT	404	17/05/2017	PASS
PHL14	KENWORTH	K108	17/05/2017	PASS
PHL38	KENWORTH	T	22/05/2017	PASS
PHL08	KENWORTH	T	24/05/2017	PASS
U789M	KRAFT	404	24/05/2017	PASS
GDU506	KENWORTH	T	29/05/2017	PASS
S532N	KRAFT	404	29/05/2017	PASS
PHL07	KENWORTH	T	31/05/2017	PASS
H469A	EVANS	4AC	31/05/2017	PASS
W970G	KRAFT	404	07/06/2017	FAIL
PHL31	KENWORTH	T	07/06/2017	PASS
W970G	KRAFT	404	08/06/2017	PASS
J880M	EVANS	4AS	14/06/2017	FAIL
PHL29	KENWORTH	K108	14/06/2017	PASS
J880M	EVANS	4AS	15/06/2017	PASS
J816F	KRAFT	400	21/06/2017	PASS
KYG607	KENWORTH	T 950	21/06/2017	FAIL
PHL18	KENWORTH	T	28/06/2017	PASS
R179F	KRAFT	404	28/06/2017	PASS
LMF809	KENWORTH	T	05/07/2017	PASS
L402L	KRAFT	404	05/07/2017	PASS
PHL22	KENWORTH	K	12/07/2017	FAIL
R462K	KRAFT	404	12/07/2017	PASS
PHL22	KENWORTH	K	13/07/2017	PASS
PHL16	KENWORTH	K108	19/07/2017	PASS
S25E	KRAFT	404	19/07/2017	PASS
PHL37	KENWORTH	T	20/07/2017	PASS
PHL28	KENWORTH	T	21/07/2017	PASS
6F838	KRAFT	400	21/07/2017	PASS
M675K	KRAFT	404	26/07/2017	PASS
KWB512	KENWORTH	K104	26/07/2017	PASS
4Z305	KRAFT	404	02/08/2017	PASS
PHL26	KENWORTH	T	02/08/2017	PASS
PHL32	KENWORTH	T	09/08/2017	PASS
W198L	KRAFT	404	09/08/2017	PASS
KYG607	KENWORTH	T 950	15/08/2017	PASS
J169L	KRAFT	400	15/08/2017	PASS
PHL34	KENWORTH	T	16/08/2017	FAIL
Y951K	KRAFT	404	16/08/2017	FAIL
Y951K	KRAFT	404	17/08/2017	PASS
PHL34	KENWORTH	T	17/08/2017	PASS
P352C	KRAFT	404	23/08/2017	PASS
PHL15	KENWORTH	T	23/08/2017	PASS
R443P	KRAFT	404	30/08/2017	PASS
PHL30	KENWORTH	K	30/08/2017	PASS
PHL20	KENWORTH	K108	06/09/2017	PASS

Released under the Official Information Act 1982



Plate	Vehicle Make	Vehicle Model	CoF Date	Result
T674A	KRAFT	404	06/09/2017	PASS
M675K	KRAFT	404	12/09/2017	PASS
KWB512	KENWORTH	K104	12/09/2017	PASS
U800M	KRAFT	404	13/09/2017	PASS
PHL21	KENWORTH	T	13/09/2017	PASS
PHL09	KENWORTH	T	18/09/2017	PASS
Z745L	KRAFT	404	18/09/2017	PASS
W730M	KRAFT	404	20/09/2017	PASS
PHL33	KENWORTH	T	20/09/2017	PASS
PHL36	KENWORTH	T	25/09/2017	PASS
6Y910	KRAFT	400	25/09/2017	PASS
K239N	KRAFT	404	27/09/2017	PASS
LCL769	KENWORTH	T	27/09/2017	PASS
AYC954	MITSUBISHI	CANTER	29/09/2017	PASS
PHL39	KENWORTH	T	29/09/2017	PASS
R177T	KRAFT	404	02/10/2017	FAIL
PHL02	KENWORTH	K108	02/10/2017	PASS
R177T	KRAFT	404	02/10/2017	PASS
M829A	KRAFT	404	03/10/2017	PASS
PHL05	KENWORTH	T	04/10/2017	PASS
K898F	KRAFT	400	04/10/2017	PASS
5W717	KRAFT	400	09/10/2017	PASS
PHL27	KENWORTH	T	09/10/2017	PASS
Z760L	KRAFT	404	11/10/2017	PASS
PHL01	KENWORTH	T	11/10/2017	PASS
PHL25	KENWORTH	T	16/10/2017	PASS
7B837	KRAFT	400	16/10/2017	PASS
LUM43	KENWORTH	T	18/10/2017	PASS
S597H	KRAFT	404	25/10/2017	PASS
PHL19	KENWORTH	K	25/10/2017	PASS
PHL23	KENWORTH	T408	30/10/2017	PASS
Q884L	KRAFT	404	30/10/2017	PASS
K438A	KRAFT	404	01/11/2017	PASS
LGC224	KENWORTH	K104	01/11/2017	PASS
PHL40	KENWORTH	T	02/11/2017	PASS
K436A	KRAFT	404	06/11/2017	PASS
LHM253	KENWORTH	K104	06/11/2017	FAIL
LHM253	KENWORTH	K104	06/11/2017	PASS
T672A	KRAFT	400	08/11/2017	PASS
PHL35	KENWORTH	T	08/11/2017	PASS
Z505Y	KRAFT	404	13/11/2017	FAIL
PHL06	KENWORTH	T	13/11/2017	PASS
Z505Y	KRAFT	404	13/11/2017	PASS
N102T	KRAFT	404	15/11/2017	PASS
PHL14	KENWORTH	K108	15/11/2017	PASS
J816F	KRAFT	400	20/11/2017	PASS
PHL08	KENWORTH	T	20/11/2017	PASS
PHL38	KENWORTH	T	22/11/2017	PASS
H469A	EVANS	4AC	29/11/2017	PASS

Released under the Official Information Act 1982

Plate	Vehicle Make	Vehicle Model	CoF Date	Result
PHL07	KENWORTH	T	29/11/2017	PASS
GDU506	KENWORTH	T	04/12/2017	PASS
S532N	KRAFT	404	04/12/2017	PASS
W970G	KRAFT	404	06/12/2017	PASS
PHL31	KENWORTH	T	06/12/2017	PASS
PHL37	KENWORTH	T	08/12/2017	FAIL
PHL37	KENWORTH	T	08/12/2017	PASS
PHL29	KENWORTH	K108	11/12/2017	PASS
J880M	EVANS	4AS	11/12/2017	PASS
R179F	KRAFT	404	13/12/2017	PASS
PHL18	KENWORTH	T	13/12/2017	PASS
U789M	KRAFT	404	14/12/2017	PASS
PHL13	KENWORTH	T	15/12/2017	PASS
6F838	KRAFT	400	20/12/2017	PASS
PHL28	KENWORTH	T	20/12/2017	PASS
L402L	KRAFT	404	27/12/2017	PASS
LMF809	KENWORTH	T	27/12/2017	PASS
S25E	KRAFT	404	29/12/2017	PASS
PHL16	KENWORTH	K108	29/12/2017	PASS
K239N	KRAFT	404	29/12/2017	PASS
LCL769	KENWORTH	T	29/12/2017	PASS
R462K	KRAFT	404	03/01/2018	PASS
PHL22	KENWORTH	K	03/01/2018	PASS
PHL26	KENWORTH	T	04/01/2018	PASS
4Z305	KRAFT	404	04/01/2018	PASS
PHL32	KENWORTH	T	07/02/2018	PASS
W198L	KRAFT	404	07/02/2018	PASS
PHL17	KENWORTH	T	07/02/2018	PASS
PHL34	KENWORTH	T	14/02/2018	PASS
Y951K	KRAFT	404	14/02/2018	PASS
PHL15	KENWORTH	T	21/02/2018	PASS
P352C	KRAFT	404	21/02/2018	PASS
PHL30	KENWORTH	K	28/02/2018	PASS
R443P	KRAFT	404	28/02/2018	PASS
PHL40	KENWORTH	T	05/03/2018	PASS
T674A	KRAFT	404	07/03/2018	PASS
PHL20	KENWORTH	K108	07/03/2018	PASS
PHL39	KENWORTH	T	12/03/2018	PASS
LGC224	KENWORTH	K104	13/03/2018	PASS
K438A	KRAFT	404	13/03/2018	PASS
PHL36	KENWORTH	T	14/03/2018	PASS
PHL21	KENWORTH	T	14/03/2018	PASS
U800M	KRAFT	404	14/03/2018	PASS
6Y910	KRAFT	400	19/03/2018	PASS
Z745L	KRAFT	404	21/03/2018	FAIL
PHL09	KENWORTH	T	21/03/2018	FAIL
Z745L	KRAFT	404	22/03/2018	PASS
PHL09	KENWORTH	T	22/03/2018	PASS
PHL33	KENWORTH	T	26/03/2018	PASS

Released under the Official Information Act 1982

Plate	Vehicle Make	Vehicle Model	CoF Date	Result
W730M	KRAFT	404	26/03/2018	PASS
LUM43	KENWORTH	T	28/03/2018	PASS
M829A	KRAFT	404	28/03/2018	PASS
AYC954	MITSUBISHI	CANTER	29/03/2018	PASS
PHL02	KENWORTH	K108	04/04/2018	PASS
R177T	KRAFT	404	04/04/2018	FAIL
R177T	KRAFT	404	05/04/2018	PASS
PHL05	KENWORTH	T	11/04/2018	PASS
K898F	KRAFT	400	11/04/2018	PASS
5W717	KRAFT	400	16/04/2018	PASS
PHL27	KENWORTH	T	16/04/2018	PASS
LHM253	KENWORTH	K104	18/04/2018	PASS
K436A	KRAFT	404	18/04/2018	PASS
Z760L	KRAFT	404	18/04/2018	PASS
PHL01	KENWORTH	T	18/04/2018	PASS
Q884L	KRAFT	404	23/04/2018	PASS
PHL23	KENWORTH	T408	23/04/2018	PASS
7B837	KRAFT	400	27/04/2018	PASS
PHL25	KENWORTH	T	27/04/2018	PASS
S597H	KRAFT	404	30/04/2018	PASS
PHL19	KENWORTH	K	30/04/2018	PASS
T672A	KRAFT	400	02/05/2018	PASS
PHL35	KENWORTH	T	02/05/2018	PASS
PHL18	KENWORTH	T	08/05/2018	PASS
PHL38	KENWORTH	T	09/05/2018	PASS
Z505Y	KRAFT	404	16/05/2018	PASS
PHL06	KENWORTH	T	16/05/2018	PASS
PHL41	KENWORTH	T	17/05/2018	PASS
PHL13	KENWORTH	T	21/05/2018	PASS
N102T	KRAFT	404	23/05/2018	PASS
PHL14	KENWORTH	K108	23/05/2018	PASS
R179F	KRAFT	404	24/05/2018	PASS
J816F	KRAFT	400	28/05/2018	PASS
PHL08	KENWORTH	T	28/05/2018	PASS
H469A	EVANS	4AC	30/05/2018	PASS
PHL07	KENWORTH	T	30/05/2018	PASS
GDU506	KENWORTH	T	06/06/2018	PASS
S532N	KRAFT	404	06/06/2018	PASS
PHL31	KENWORTH	T	13/06/2018	PASS
W970G	KRAFT	404	13/06/2018	PASS
LMF809	KENWORTH	T	14/06/2018	PASS
L402L	KRAFT	404	14/06/2018	PASS
U789M	KRAFT	404	20/06/2018	PASS
PHL29	KENWORTH	K108	20/06/2018	PASS
PHL37	KENWORTH	T	27/06/2018	PASS
6F838	KRAFT	400	04/07/2018	PASS
PHL28	KENWORTH	T	04/07/2018	PASS
S25E	KRAFT	404	11/07/2018	PASS
PHL16	KENWORTH	K108	11/07/2018	PASS

Released under the Official Information Act 1982

Plate	Vehicle Make	Vehicle Model	CoF Date	Result
PHL42	KENWORTH	T	13/07/2018	PASS
R462K	KRAFT	404	18/07/2018	PASS
PHL22	KENWORTH	K	18/07/2018	PASS
PHL43	KENWORTH	T	24/07/2018	PASS
PHL17	KENWORTH	T	25/07/2018	PASS
4Z305	KRAFT	404	01/08/2018	PASS
PHL26	KENWORTH	T	01/08/2018	PASS
PHL10	KENWORTH	T	03/08/2018	PASS
W198L	KRAFT	404	08/08/2018	PASS
PHL32	KENWORTH	T	08/08/2018	PASS
Y951K	KRAFT	404	15/08/2018	PASS
PHL34	KENWORTH	T	15/08/2018	PASS
P352C	KRAFT	404	22/08/2018	PASS
PHL15	KENWORTH	T	22/08/2018	PASS
PHL30	KENWORTH	K	29/08/2018	PASS
R443P	KRAFT	404	29/08/2018	PASS
PHL20	KENWORTH	K108	05/09/2018	PASS
T674A	KRAFT	404	05/09/2018	PASS
PHL39	KENWORTH	T	10/09/2018	PASS
6Y910	KRAFT	400	12/09/2018	PASS
PHL36	KENWORTH	T	12/09/2018	PASS
PHL21	KENWORTH	T	17/09/2018	PASS
U800M	KRAFT	404	17/09/2018	PASS
Z745L	KRAFT	404	19/09/2018	PASS
PHL09	KENWORTH	T	19/09/2018	PASS
AYC954	MITSUBISHI	CANTER	21/09/2018	FAIL
PHL40	KENWORTH	T	24/09/2018	PASS
AYC954	MITSUBISHI	CANTER	25/09/2018	PASS
PHL33	KENWORTH	T	26/09/2018	PASS
W730M	KRAFT	404	26/09/2018	PASS
M829A	KRAFT	404	03/10/2018	PASS
LUM43	KENWORTH	T	03/10/2018	PASS
R177T	KRAFT	404	08/10/2018	PASS
PHL02	KENWORTH	K108	08/10/2018	PASS
K898F	KRAFT	400	10/10/2018	PASS
PHL05	KENWORTH	T	10/10/2018	PASS
5W717	KRAFT	400	15/10/2018	PASS
PHL27	KENWORTH	T	15/10/2018	PASS
Z760L	KRAFT	404	17/10/2018	PASS
PHL01	KENWORTH	T	17/10/2018	PASS
PHL23	KENWORTH	T408	24/10/2018	PASS
Q884L	KRAFT	404	24/10/2018	PASS
7B837	KRAFT	400	29/10/2018	PASS
PHL25	KENWORTH	T	29/10/2018	FAIL
PHL25	KENWORTH	T	29/10/2018	PASS
PHL14	KENWORTH	K108	30/10/2018	PASS
N102T	KRAFT	404	30/10/2018	PASS
PHL19	KENWORTH	K	31/10/2018	PASS
S597H	KRAFT	404	31/10/2018	PASS

Released under the Official Information Act 1982

Plate	Vehicle Make	Vehicle Model	CoF Date	Result
R179F	KRAFT	404	05/11/2018	PASS
PHL18	KENWORTH	T	05/11/2018	PASS
PHL35	KENWORTH	T	07/11/2018	PASS
PHL41	KENWORTH	T	12/11/2018	PASS
PHL06	KENWORTH	T	14/11/2018	PASS
Z505Y	KRAFT	404	14/11/2018	PASS
PHL38	KENWORTH	T	19/11/2018	PASS
H469A	EVANS	4AC	21/11/2018	PASS
PHL07	KENWORTH	T	21/11/2018	PASS
PHL13	KENWORTH	T	26/11/2018	PASS
J816F	KRAFT	400	28/11/2018	PASS
PHL08	KENWORTH	T	28/11/2018	PASS
PHL37	KENWORTH	T	03/12/2018	PASS
S532N	KRAFT	404	05/12/2018	PASS
GDU506	KENWORTH	T	05/12/2018	PASS
W970G	KRAFT	404	10/12/2018	PASS
PHL31	KENWORTH	T	10/12/2018	PASS
PHL42	KENWORTH	T	12/12/2018	PASS
6F838	KRAFT	400	17/12/2018	PASS
PHL28	KENWORTH	T	17/12/2018	PASS
U789M	KRAFT	404	19/12/2018	PASS
PHL29	KENWORTH	K108	19/12/2018	PASS
PHL03	KENWORTH	T	20/12/2018	PASS
S25E	KRAFT	404	27/12/2018	PASS
PHL16	KENWORTH	K108	27/12/2018	PASS
4Z305	KRAFT	404	28/12/2018	PASS
PHL26	KENWORTH	T	28/12/2018	PASS
PHL43	KENWORTH	T	03/01/2019	PASS
PHL17	KENWORTH	T	04/01/2019	PASS
PHL10	KENWORTH	T	07/01/2019	PASS
R462K	KRAFT	404	09/01/2019	PASS
PHL04	KENWORTH	T	10/01/2019	PASS
W198L	KRAFT	404	04/02/2019	PASS
PHL32	KENWORTH	T	04/02/2019	PASS
J169L	KRAFT	400	05/02/2019	PASS
PHL34	KENWORTH	T	11/02/2019	PASS
Y951K	KRAFT	404	11/02/2019	PASS
P352C	KRAFT	404	13/02/2019	PASS
PHL15	KENWORTH	T	13/02/2019	PASS
PHL30	KENWORTH	K	20/02/2019	PASS
R443P	KRAFT	404	20/02/2019	PASS
PHL20	KENWORTH	K108	27/02/2019	PASS
T674A	KRAFT	404	27/02/2019	PASS

Released under the Official Information Act 1982

### Summary of Passes and Fails

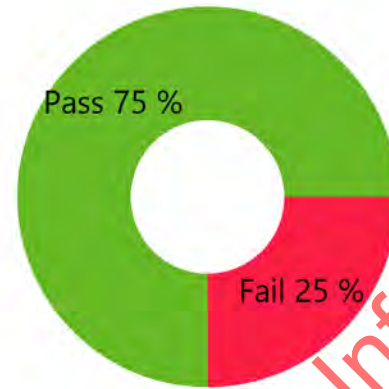

Total Fails:	5
% of Vehicles Failed:	25.0%
Total Passes:	15
% of Vehicles Passed:	75.0%
No. Faults Found:	6

### Frequency of Faults



Fault Category	# Faults	% of Vehicles
Brakes	2	33%
Lighting	1	17%
Motive	1	17%
Suspension	1	17%
Wheels, Tyres & Mudguards	1	17%
<b>Total</b>	<b>6</b>	<b>100%</b>

Released under the Official Information Act 1982

### Summary of Passes and Fails

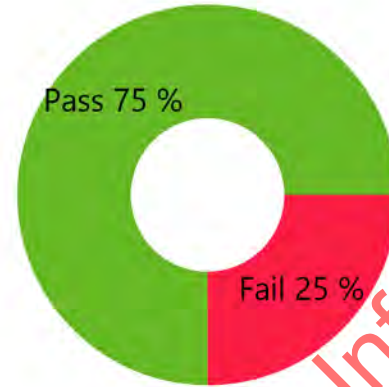

Total Fails:	5
% of Vehicles Failed:	25.0%
Total Passes:	15
% of Vehicles Passed:	75.0%
No. Faults Found:	6

### Frequency of Faults

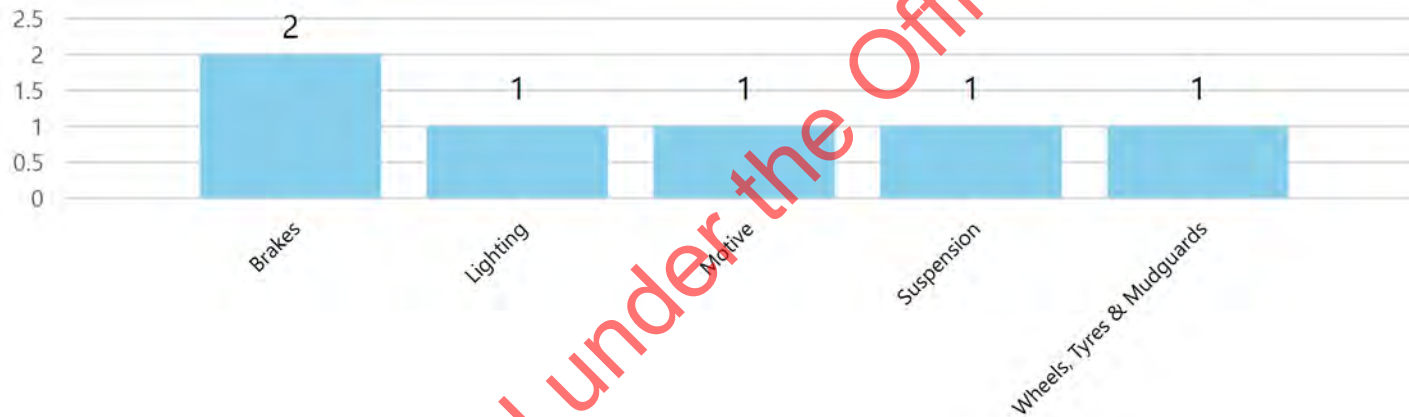

Fault Category	# Faults	% of Vehicles
Brakes	2	33%
Lighting	1	17%
Motive	1	17%
Suspension	1	17%
Wheels, Tyres & Mudguards	1	17%
<b>Total</b>	<b>6</b>	<b>100%</b>

### Summary of Passes and Fails

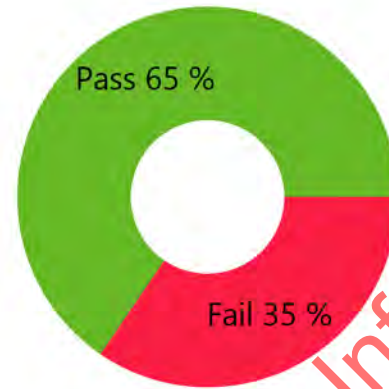

Total Fails:	97
% of Vehicles Failed:	34.5%
Total Passes:	184
% of Vehicles Passed:	65.5%
No. Faults Found:	130

### Frequency of Faults



Fault Category	# Faults	% of Vehicles
Brakes	33	25%
Cab, Chassis and Body	5	4%
Exhaust System	2	2%
Exterior	8	6%
Interior	2	2%
Lighting	44	34%
Motive	5	4%
PSV Wheels and Tyres	1	1%
Suspension	8	6%
Towing & 5th Wheel	5	4%
Wheels, Tyres & Mudguards	17	13%
<b>Total</b>	<b>130</b>	<b>100%</b>



### Summary of Passes and Fails

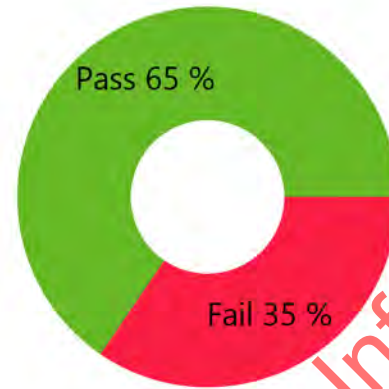

Total Fails:	97
% of Vehicles Failed:	34.5%
Total Passes:	184
% of Vehicles Passed:	65.5%
No. Faults Found:	130

### Frequency of Faults



Fault Category	# Faults	% of Vehicles
Brakes	33	25%
Cab, Chassis and Body	5	4%
Exhaust System	2	2%
Exterior	8	6%
Interior	2	2%
Lighting	44	34%
Motive	5	4%
PSV Wheels and Tyres	1	1%
Suspension	8	6%
Towing & 5th Wheel	5	4%
Wheels, Tyres & Mudguards	17	13%
<b>Total</b>	<b>130</b>	<b>100%</b>

09 August 2019

s9(2)(a)

Pacific Haulage Limited  
107 Aerodrome Road  
Gisborne 4071

Dear s9(2)(a)

### Audit Outcome

I would like to thank you and s9(2)(a) for your time on Thursday the 25<sup>th</sup> of July 2019 at your office in Gisborne.

Both Wendy & I felt that the meeting was hugely beneficial to both parties and were very impressed with the proactive approach that s9(2)(a) has taken with the company since he has come onboard. In many instances the concerns we had have already been addressed, with programs and processes put in place.

Through the conversations we had with s9(2)(a) he was able to provide the answers we were after, but at the same time was willing to take on some of the advice we also provided around managing driver offending and improving roadside pass rates. This cooperative approach is the best way forward, and I have been pleased to see this continue with s9(2)(a) contacting me directly on a number of occasions since our meeting.

The outcome of the roadside operations was also pleasing to see with a reduction in roadside faults located. There was also a noticeable difference in the quality of the logbooks produced. At the beginning of the audit your RID pass rate was 54%. Prior to our meeting this had increased to 63% and following the two days of roadside inspections it has continued to rise.

Therefore, we are pleased to advise that we have concluded our audit. We will however undertake a 3-monthly review over the next 12 months to monitor the progress of Pacific Haulage and ensure that improvements are continued to be made.

We look forward to maintaining contact with both yourself and s9(2)(a) and are more than happy to offer our services at any stage if we are able to be of any further assistance.

Yours sincerely,

s9(2)(a)

**Nathan Murrell**  
Commercial Transport Officer

Released under the Official Information Act 1982

Operation:	<b>Roadside Inspection Checks</b>			
	From 22/07/2017 To 22/07/2019			
Operator:	s18(c)(i)			
Operator Name:	<b>PACIFIC HAULAGE LIMITED</b>			
Roadside Inspections:	<b>119</b>	Vehicles Inspected:	<b>212</b>	Vehicles with Faults: <b>78</b>

Insp Date	CVIR Sheet #	QID	Plate	Vehicle Types Meaning	Insp Result	Insp Lvl	Fault Action	Fault Category	Fault desc	COF Expiry Date
22/07/2017	768999	ATY330	7P447	Trailer/caravan	Pass	5	No Action			12/01/2018
22/07/2017	768999	ATY330	PHL37	Goods van/truck/utility	Pass	5	No Action			20/01/2018
01/08/2017	822421	RBC411	H469A	Trailer/caravan	Fail	5, 3	Green 2 action	Brakes	Air leaks any other system	03/12/2017
01/08/2017	822421	RBC411	PHL07	Goods van/truck/utility	Pass	5, 3	No Action			16/12/2017
11/08/2017	822440	RBC411	PHL13	Goods van/truck/utility	Fail	5, 3	Green 2 action	Brakes	Air leaks any other system	30/01/2018
22/08/2017	826921	RBC411	K898F	Trailer/caravan	Pass	5, 3	No Action			13/10/2017
22/08/2017	826921	RBC411	PHL05	Goods van/truck/utility	Fail	5, 3	Green 2 action	Lighting	One direction Indicator lamp not working	08/11/2017
05/09/2017	826949	RBC411	PHL35	Goods van/truck/utility	Pass	3	No Action			17/11/2017
05/09/2017	826949	RBC411	T672A	Trailer/caravan	Pass	3	No Action			08/11/2017
08/09/2017	826958	RBC411	L402L	Trailer/caravan	Fail	3	Pink sticker	Lighting	All side marker lamps not operational (during darkness)	13/01/2018
08/09/2017	826958	RBC411	L402L	Trailer/caravan	Fail	3	Pink sticker	Lighting	A rear tail lamp is not operational (during darkness) no other rear right lamp operational	13/01/2018
08/09/2017	826958	RBC411	PHL11	Goods van/truck/utility	Pass	3	No Action			13/01/2018
11/09/2017	830316	RBC411	PHL01	Goods van/truck/utility	Pass	3	No Action			04/11/2017
03/10/2017	832193	GGI670	PHL23	Goods van/truck/utility	Fail	5, 3	Green 2 action	Load Anchorage	Bolster not securely fitted or attachment is damaged – no immediate risk of failure	21/11/2017
03/10/2017	832193	GGI670	Q884L	Trailer/caravan	Fail	5, 3	Green sticker	Brakes	Stroke of brake chamber exceeds manufacturer's limit - service brake performance doesn't meet legal requirements	30/10/2017
03/10/2017	828698	GME708	J880M	Trailer/caravan	Pass	5, 3	No Action			22/12/2017
03/10/2017	828698	GME708	PHL29	Goods van/truck/utility	Pass	5, 3	No Action			21/12/2017
03/10/2017	833892	PJAT18	M829A	Trailer/caravan	Fail	5, 3	Pink sticker	Suspension	Leaf spring or coil spring broken, missing or seriously damaged.	03/04/2018

Insp Date	CVIR Sheet #	QID	Plate	Vehicle Types Meaning	Insp Result	Insp Lvl	Fault Action	Fault Category	Fault desc	COF Expiry Date
03/10/2017	833892	PJAT18	PHL12	Goods van/truck/utility	Fail	5, 3	Pink sticker	Brakes	Park brake actuator missing/not operational/does not lock into position, remains applied when released, is not securely fastened & may detach. Risk of inadvertent release	24/10/2017
03/10/2017	830350	RBC411	7B837	Trailer/caravan	Fail	5, 3	Green 2 action	Cab, Chassis and Body	Load containment structure damaged or not securely fitted - risk of failure, vehicle unloaded (includes cab guard)	28/10/2017
03/10/2017	830350	RBC411	PHL25	Goods van/truck/utility	Pass	5, 3	No Action			02/11/2017
03/10/2017	833895	PJAT18	5W717	Trailer/caravan	Pass	5, 3	No Action			31/10/2017
03/10/2017	833895	PJAT18	PHL27	Goods van/truck/utility	Pass	5, 3	No Action			19/10/2017
04/10/2017	832202	GGI670	J880M	Trailer/caravan	Fail	5, 3	Pink sticker	Wheels and Tyres	A tyre is damaged – operation affected and/or failure imminent	22/12/2017
04/10/2017	832202	GGI670	PHL29	Goods van/truck/utility	Pass	5, 3	No Action			21/12/2017
04/10/2017	832205	GGI670	PHL20	Goods van/truck/utility	Pass	5, 3	No Action			06/03/2018
04/10/2017	832205	GGI670	T674A	Trailer/caravan	Pass	5, 3	No Action			07/03/2018
04/10/2017	832209	GGI670	GDU506	Goods van/truck/utility	Pass	5, 3	No Action			05/12/2017
04/10/2017	832209	GGI670	S532N	Trailer/caravan	Pass	5, 3	No Action			20/12/2017
04/10/2017	832115	GME708	7K728	Trailer/caravan	Pass	5, 3	No Action			21/12/2017
04/10/2017	832115	GME708	PHL38	Goods van/truck/utility	Pass	5, 3	No Action			22/11/2017
04/10/2017	830360	RBC411	K239N	Trailer/caravan	Pass	5, 3	No Action			30/03/2018
04/10/2017	830360	RBC411	PHL10	Goods van/truck/utility	Pass	5, 3	No Action			30/03/2018
05/10/2017	834833	NRV683	PHL35	Goods van/truck/utility	Fail	5, 3	Green 2 action	Lighting	A headlamp is damaged failure is imminent or light output on either side is not approx equal	17/11/2017
05/10/2017	834833	NRV683	T672A	Trailer/caravan	Fail	5, 3	Green 2 action	PSV Wheels and Tyres	Tread in dual set 1 tyre below minimum	08/11/2017
05/10/2017	836073	PJAT18	PHL22	Goods van/truck/utility	Fail	5, 3	Pink sticker	Brakes	Park brake actuator missing/not operational/does not lock into position, remains applied when released, is not securely fastened & may detach. Risk of inadvertent release	26/01/2018
05/10/2017	836073	PJAT18	R462K	Trailer/caravan	Pass	5, 3	No Action			26/01/2018
11/10/2017	833637	RBC411	H469A	Trailer/caravan	Fail	3	Green 2 action	Brakes	Air leaks any other system	03/12/2017
11/10/2017	833637	RBC411	PHL07	Goods van/truck/utility	Pass	3	No Action			16/12/2017
19/10/2017	833650	RBC411	K438A	Trailer/caravan	Fail	3	Pink sticker	Wheels and Tyres	A tyre is damaged – operation affected and/or failure imminent	17/11/2017
19/10/2017	833650	RBC411	PHL04	Goods van/truck/utility	Fail	3	Green 2 action	Load Anchorage	Bolster not securely fitted or attachment is damaged – no immediate risk of failure	02/11/2017

Insp Date	CVIR Sheet #	QID	Plate	Vehicle Types Meaning	Insp Result	Insp Lvl	Fault Action	Fault Category	Fault desc	COF Expiry Date
01/11/2017	837227	RBC411	PHL36	Goods van/truck/utility	Fail	3	Green sticker	Lighting	Direction indicator lamp is damaged, fully obscured or output affected/failure imminent or is not securely fitted (detachment is imminent)	30/03/2018
02/11/2017	837235	RBC411	5W717	Trailer/caravan	Fail	3	Pink sticker	Lighting	No stop lamps fitted, no stop lamps working, are excessively damaged or fully obscured. Single vehicle or rear unit of combo	30/04/2018
02/11/2017	837235	RBC411	PHL27	Goods van/truck/utility	Fail	3	Green sticker	Lighting	One or more than two daytime running lamps fitted	19/04/2018
02/11/2017	837235	RBC411	PHL27	Goods van/truck/utility	Fail	3	Green 2 action	Lighting	A headlamp is damaged failure is imminent or light output on either side is not approx equal	19/04/2018
14/11/2017	814676	BLDA87	K438A	Trailer/caravan	Fail	5	Pink sticker	Lighting	No stop lamps fitted, no stop lamps working, are excessively damaged or fully obscured. Single vehicle or rear unit of combo	17/05/2018
14/11/2017	814676	BLDA87	PHL04	Goods van/truck/utility	Pass	5	No Action			02/05/2018
30/11/2017	837267	RBC411	K239N	Trailer/caravan	Fail	5, 3	Green 2 action	Lighting	Side marker lamp not operational, not secure, damaged or obscured	30/03/2018
30/11/2017	837267	RBC411	PHL10	Goods van/truck/utility	Fail	5, 3	Green 2 action	Lighting	One or more front park lamps not operational (anytime)	30/03/2018
05/12/2017	839682	RBC411	PHL10	Goods van/truck/utility	Fail	3	Green 2 action	Lighting	One or more front park lamps not operational (anytime)	30/03/2018
05/12/2017	839683	RBC411	PHL04	Goods van/truck/utility	Pass	3	No Action			02/05/2018
11/01/2018	841627	BWD335	PHL16	Goods van/truck/utility	Fail	5, 3	Green sticker	Mudguards	One mudguard missing/does not comply or a mudflap not fitted to a twin tyred axle	26/07/2018
11/01/2018	841627	BWD335	PHL16	Goods van/truck/utility	Fail	5, 3	Pink sticker	Wheels and Tyres	A tyre is damaged – operation affected and/or failure imminent	26/07/2018
11/01/2018	841627	BWD335	S25E	Trailer/caravan	Pass	5, 3	No Action			26/07/2018
18/01/2018	837646	BLDA87	6Y910	Trailer/caravan	Pass	5	No Action			18/01/2018
18/01/2018	837646	BLDA87	PHL36	Goods van/truck/utility	Pass	5	No Action			18/01/2018
08/02/2018	843246	BLDA87	PHL31	Goods van/truck/utility	Fail	5	Green 2 action	Lighting	A headlamp is damaged failure is imminent or light output on either side is not approx equal	18/06/2018
08/02/2018	843246	BLDA87	W970G	Trailer/caravan	Pass	5	No Action			18/06/2018
27/02/2018	854254	BWD335	PHL06	Goods van/truck/utility	Pass	5, 3	No Action			26/05/2018
27/02/2018	854254	BWD335	Z505Y	Trailer/caravan	Pass	5, 3	No Action			21/05/2018
03/04/2018	854929	RBC411	PHL26	Goods van/truck/utility	Pass	3	No Action			01/08/2018

Insp Date	CVIR Sheet #	QID	Plate	Vehicle Types Meaning	Insp Result	Insp Lvl	Fault Action	Fault Category	Fault desc	COF Expiry Date
13/04/2018	850703	BLDA87	PHL02	Goods van/truck/utility	Fail	5	Green 2 action	Wheels and Tyres	1 wheel nut loose/missing, 1 stud damaged/missing	07/10/2018
13/04/2018	850703	BLDA87	R177T	Trailer/caravan	Pass	5	No Action			07/10/2018
16/04/2018	854940	RBC411	P352C	Trailer/caravan	Pass	3	No Action			20/09/2018
16/04/2018	854940	RBC411	PHL15	Goods van/truck/utility	Fail	3	Green 2 action	Load Anchorage	Bolster not securely fitted or attachment is damaged – no immediate risk of failure	01/09/2018
26/04/2018	857314	RBC411	PHL02	Goods van/truck/utility	Pass	3	No Action			07/10/2018
26/04/2018	857314	RBC411	R177T	Trailer/caravan	Fail	3	Green 2 action	Lighting	One required rear reflector fitted, not securely fitted, colour other than red, anytime	07/10/2018
03/05/2018	854337	BWD335	PHL18	Goods van/truck/utility	Pass	5, 3	No Action			08/11/2018
11/05/2018	850731	BLDA87	PHL29	Goods van/truck/utility	Pass	5	No Action			21/06/2018
11/05/2018	850731	BLDA87	U789M	Trailer/caravan	Pass	5	No Action			21/06/2018
17/05/2018	850732	BLDA87	PHL23	Goods van/truck/utility	Pass	5	No Action			21/11/2018
20/06/2018	857357	RBC411	PHL32	Goods van/truck/utility	Pass	3	No Action			26/08/2018
20/06/2018	857358	RBC411	PHL27	Goods van/truck/utility	Fail	3	Pink sticker	Lighting	No stop lamps fitted, no stop lamps working, are excessively damaged or fully obscured. Single vehicle or rear unit of combo	19/10/2018
20/06/2018	857359	RBC411	GDU506	Goods van/truck/utility	Fail	3	Green 2 action	Lighting	Daytime running lamp works intermittently/operates with fog lights, not securely fitted or damaged	06/12/2018
25/06/2018	861239	RBC411	PHL20	Goods van/truck/utility	Fail	3	Green 2 action	Lighting	A fog lamp is insecure, damaged or out of alignment	07/09/2018
25/06/2018	861239	RBC411	PHL20	Goods van/truck/utility	Fail	3	Green 2 action	Lighting	One direction Indicator lamp not working	07/09/2018
25/06/2018	861239	RBC411	PHL20	Goods van/truck/utility	Fail	3	Green 2 action	Lighting	One required rear reflector fitted, not securely fitted, colour other than red, anytime	07/09/2018
25/06/2018	861240	RBC411	PHL02	Goods van/truck/utility	Fail	3	Green sticker	Lighting	Direction indicator lamp is damaged, fully obscured or output affected/failure imminent or is not securely fitted (detachment is imminent)	07/10/2018
25/06/2018	861241	RBC411	PHL12	Goods van/truck/utility	Fail	3	Green 2 action	Lighting	One direction Indicator lamp not working	24/10/2018
25/06/2018	861241	RBC411	PHL12	Goods van/truck/utility	Fail	3	Green 2 action	Lighting	One or more front park lamps not operational (anytime)	24/10/2018
07/07/2018	861259	RBC411	7P447	Trailer/caravan	Pass	3	No Action			06/01/2019
07/07/2018	861259	RBC411	PHL37	Goods van/truck/utility	Pass	3	No Action			06/01/2019
13/07/2018	861267	RBC411	PHL37	Goods van/truck/utility	Fail	3	Green sticker	Mudguards	One mudguard missing/does not comply or a mudflap not fitted to a twin tyred axle	06/01/2019

Insp Date	CVIR Sheet #	QID	Plate	Vehicle Types Meaning	Insp Result	Insp Lvl	Fault Action	Fault Category	Fault desc	COF Expiry Date
17/07/2018	861276	RBC411	PHL07	Goods van/truck/utility	Fail	3	Green 2 action	Lighting	Stop lamp emits colour other than red, or is obscured	16/12/2018
10/08/2018	867923	RBC411	PHL02	Goods van/truck/utility	Pass	2	No Action			07/10/2018
10/08/2018	867923	RBC411	R177T	Trailer/caravan	Fail	2	Pink sticker	Load Anchorage	Sliding bolster – no locking mechanism	07/10/2018
10/08/2018	867923	RBC411	R177T	Trailer/caravan	Fail	2	Green 2 action	Lighting	One direction Indicator lamp not working	07/10/2018
10/08/2018	867925	RBC411	GDU506	Goods van/truck/utility	Fail	3	Green 2 action	Lighting	Daytime running lamp works intermittently/operates with fog lights, not securely fitted or damaged	06/12/2018
16/08/2018	872864	RBC411	M829A	Trailer/caravan	Fail	3	Green 2 action	Lighting	One required rear reflector fitted, not securely fitted, colour other than red, anytime	03/10/2018
16/08/2018	872864	RBC411	PHL12	Goods van/truck/utility	Pass	3	No Action			24/10/2018
17/08/2018	872868	RBC411	9Z516	Trailer/caravan	Pass	3	No Action			24/01/2019
17/08/2018	872868	RBC411	PHL43	Goods van/truck/utility	Pass	3	No Action			24/01/2019
17/09/2018	872898	RBC411	PHL01	Goods van/truck/utility	Pass	5, 3	No Action			04/11/2018
17/09/2018	872898	RBC411	Z760L	Trailer/caravan	Fail	5, 3	Pink sticker	Lighting	No stop lamps fitted, no stop lamps working, are excessively damaged or fully obscured. Single vehicle or rear unit of combo	23/10/2018
27/09/2018	097707	RBC411	PHL05	Goods van/truck/utility	Fail	5, 3	Green 2 action	Lighting	One required headlamp is not fitted, not securely attached or is not operational	02/11/2018
03/10/2018	114451	RBC411	PHL30	Goods van/truck/utility	Pass	5, 3	No Action			04/03/2019
03/10/2018	114451	RBC411	R443P	Trailer/caravan	Fail	5, 3	Pink sticker	Load Anchorage	Sliding bolster – no locking mechanism	02/03/2019
26/10/2018	105572	BWD335	K898F	Trailer/caravan	Fail	5, 3	Pink sticker	Lighting	No stop lamps fitted, no stop lamps working, are excessively damaged or fully obscured. Single vehicle or rear unit of combo	13/04/2019
26/10/2018	105572	BWD335	PHL05	Goods van/truck/utility	Pass	5, 3	No Action			02/05/2019
30/10/2018	105582	BWD335	PHL12	Goods van/truck/utility	Pass	5, 3	No Action			24/04/2019
08/11/2018	114485	RBC411	PHL06	Goods van/truck/utility	Pass	5, 3	No Action			26/11/2018
08/11/2018	114485	RBC411	Z505Y	Trailer/caravan	Pass	5, 3	No Action			21/11/2018
12/11/2018	117905	JB227	PHL32	Goods van/truck/utility	Fail	5, 3	Green sticker	Exhaust System	Exhaust system not effective, loose, leaks or excessive noise	26/02/2019
12/11/2018	117905	JB227	W198L	Trailer/caravan	Fail	5, 3	Pink sticker	Brakes	ABS/EBS system is not operating - Combination vehicle	21/02/2019
13/11/2018	117057	BWD335	9Z511	Trailer/caravan	Pass	5, 3	No Action			13/01/2019
13/11/2018	117057	BWD335	PHL42	Goods van/truck/utility	Pass	5, 3	No Action			13/01/2019

Insp Date	CVIR Sheet #	QID	Plate	Vehicle Types Meaning	Insp Result	Insp Lvl	Fault Action	Fault Category	Fault desc	COF Expiry Date
13/11/2018	117159	WHG676	PHL16	Goods van/truck/utility	Pass	5, 3	No Action			26/01/2019
13/11/2018	117159	WHG676	S25E	Trailer/caravan	Pass	5, 3	No Action			26/01/2019
13/11/2018	114496	RBC411	PHL35	Goods van/truck/utility	Fail	5, 3	Green sticker	Brakes	Spring brake/electric brake control for parking brakes not protected from inadvertent release	17/05/2019
13/11/2018	114496	RBC411	T672A	Trailer/caravan	Pass	5, 3	No Action			08/05/2019
13/11/2018	105599	BWD335	6Y910	Trailer/caravan	Fail	5, 3	Green 2 action	Brakes	Suzie coil hose does not comply, support spring missing/ineffective	19/03/2019
13/11/2018	105599	BWD335	PHL36	Goods van/truck/utility	Pass	5, 3	No Action			14/03/2019
13/11/2018	114499	RBC411	K898F	Trailer/caravan	Fail	5, 3	Green 2 action	Load Anchorage	Bolster not securely fitted or attachment is damaged – no immediate risk of failure	13/04/2019
13/11/2018	114499	RBC411	PHL05	Goods van/truck/utility	Fail	5, 3	Green sticker	Brakes	Spring brake/electric brake control for parking brakes not protected from inadvertent release	02/05/2019
13/11/2018	114499	RBC411	PHL05	Goods van/truck/utility	Fail	5, 3	Pink sticker	Wheels and Tyres	Wheel nuts loose/missing or studs damaged/missing - safety risk	02/05/2019
14/11/2018	117925	JB227	PHL23	Goods van/truck/utility	Pass	5, 3	No Action			21/05/2019
14/11/2018	117925	JB227	Q884L	Trailer/caravan	Fail	5, 3	Pink sticker	Suspension	Suspension component not fitted/not securely fitted	30/04/2019
14/11/2018	117925	JB227	Q884L	Trailer/caravan	Fail	5, 3	Green 2 action	Wheels and Tyres	Tyre not correctly inflated – operation/control not affected	30/04/2019
14/11/2018	114553	RBC411	PHL20	Goods van/truck/utility	Fail	5, 3	Green sticker	Brakes	Spring brake/electric brake control for parking brakes not protected from inadvertent release	07/03/2019
14/11/2018	114553	RBC411	PHL20	Goods van/truck/utility	Fail	5, 3	Green sticker	Suspension	Shock absorber missing, damaged or leaking excessively (wet or dripping)	07/03/2019
14/11/2018	114553	RBC411	T674A	Trailer/caravan	Fail	5, 3	Pink sticker	Brakes	Air leak low air pressure <30 seconds	07/03/2019
14/11/2018	114553	RBC411	T674A	Trailer/caravan	Fail	5, 3	Green 2 action	Load Anchorage	Bolster not securely fitted or attachment is damaged – no immediate risk of failure	07/03/2019
14/11/2018	114556	RBC411	6F838	Trailer/caravan	Fail	5, 3	Green 2 action	Brakes	Suzie coil hose does not comply, support spring missing/ineffective	18/01/2019
14/11/2018	114556	RBC411	6F838	Trailer/caravan	Fail	5, 3	Pink sticker	Brakes	ABS/EBS system is not operating - Combination vehicle	18/01/2019
14/11/2018	114556	RBC411	6F838	Trailer/caravan	Fail	5, 3	Green 2 action	Lighting	One required rear reflector fitted, not securely fitted, colour other than red, anytime	18/01/2019
14/11/2018	114556	RBC411	6F838	Trailer/caravan	Fail	5, 3	Green 2 action	Ball-race Turntables	Ball-race turntable fasteners loose (other)	18/01/2019
14/11/2018	114556	RBC411	PHL28	Goods van/truck/utility	Fail	5, 3	Green 2 action	Lighting	Daytime running lamp works intermittently/operates with fog lights, not securely fitted or damaged	18/01/2019



Insp Date	CVIR Sheet #	QID	Plate	Vehicle Types Meaning	Insp Result	Insp Lvl	Fault Action	Fault Category	Fault desc	COF Expiry Date
14/11/2018	114556	RBC411	PHL28	Goods van/truck/utility	Fail	5, 3	Green 2 action	Lighting	One required headlamp is not fitted, not securely attached or is not operational	18/01/2019
14/11/2018	117929	JB227	PHL18	Goods van/truck/utility	Pass	5, 3	No Action			08/05/2019
14/11/2018	117929	JB227	R179F	Trailer/caravan	Pass	5, 3	No Action			24/05/2019
14/11/2018	114558	RBC411	N102T	Trailer/caravan	Fail	5, 3	Green 2 action	Lighting	One direction Indicator lamp not working	30/04/2019
14/11/2018	114558	RBC411	PHL14	Goods van/truck/utility	Fail	5, 3	Green sticker	Brakes	Spring brake/electric brake control for parking brakes not protected from inadvertent release	30/04/2019
14/11/2018	114558	RBC411	PHL14	Goods van/truck/utility	Fail	5, 3	Green sticker	Exhaust System	Exhaust system not effective, loose, leaks or excessive noise	30/04/2019
14/11/2018	114558	RBC411	PHL14	Goods van/truck/utility	Fail	5, 3	Green 2 action	Fluid Leaks	Fluid leaks other	30/04/2019
15/11/2018	117173	WHG676	4Z305	Trailer/caravan	Pass	5, 3	No Action			01/02/2019
15/11/2018	117173	WHG676	PHL26	Goods van/truck/utility	Pass	5, 3	No Action			01/02/2019
15/11/2018	117175	WHG676	5W717	Trailer/caravan	Fail	5, 3	Green sticker	Brakes	Stroke of brake chamber exceeds manufacturer's limit - service brake performance doesn't meet legal requirements	30/04/2019
15/11/2018	117175	WHG676	PHL27	Goods van/truck/utility	Pass	5, 3	No Action			19/04/2019
15/11/2018	114567	RBC411	PHL34	Goods van/truck/utility	Pass	5, 3	No Action			27/02/2019
15/11/2018	114567	RBC411	Y951K	Trailer/caravan	Fail	5, 3	Green sticker	Brakes	Air leak low air pressure >30 seconds	28/02/2019
15/11/2018	114567	RBC411	Y951K	Trailer/caravan	Fail	5, 3	Green sticker	Brakes	Reservoir/master cylinder/servo unit leaks, or is loose/otherwise damaged or worn	28/02/2019
15/11/2018	121785	WDJ177	9Z506	Trailer/caravan	Pass	5, 3	No Action			09/06/2019
15/11/2018	121785	WDJ177	PHL41	Goods van/truck/utility	Pass	5, 3	No Action			17/05/2019
15/11/2018	121783	WDJ177	PHL02	Goods van/truck/utility	Pass	5, 3	No Action			08/04/2019
15/11/2018	121783	WDJ177	R177T	Trailer/caravan	Fail	5, 3	Pink sticker	Wheels and Tyres	Side wall unzipping	08/04/2019
15/11/2018	117941	JB227	9Z516	Trailer/caravan	Pass	5, 3	No Action			24/01/2019
15/11/2018	117941	JB227	PHL43	Goods van/truck/utility	Pass	5, 3	No Action			24/01/2019
26/11/2018	114589	RBC411	4Z305	Trailer/caravan	Pass	5, 3	No Action			01/02/2019
26/11/2018	114589	RBC411	PHL26	Goods van/truck/utility	Pass	5, 3	No Action			01/02/2019
03/12/2018	114599	RBC411	PHL33	Goods van/truck/utility	Fail	5, 3	Green sticker	Brakes	Spring brake/electric brake control for parking brakes not protected from inadvertent release	03/04/2019
03/12/2018	114599	RBC411	PHL33	Goods van/truck/utility	Fail	5, 3	Green 2 action	Lighting	One required headlamp is not fitted, not securely attached or is not operational	03/04/2019
03/12/2018	123554	RBC411	PHL09	Goods van/truck/utility	Pass	5, 3	No Action			25/03/2019

Insp Date	CVIR Sheet #	QID	Plate	Vehicle Types Meaning	Insp Result	Insp Lvl	Fault Action	Fault Category	Fault desc	COF Expiry Date
03/12/2018	123554	RBC411	Z745L	Trailer/caravan	Pass	5, 3	No Action			24/03/2019
12/12/2018	107316	PNIQ51	4Z305	Trailer/caravan	Pass	5, 3	No Action			01/02/2019
12/12/2018	107316	PNIQ51	PHL26	Goods van/truck/utility	Pass	5, 3	No Action			01/02/2019
12/12/2018	107318	PNIQ51	PHL20	Goods van/truck/utility	Pass	5, 3	No Action			07/03/2019
12/12/2018	107318	PNIQ51	T674A	Trailer/caravan	Fail	5, 3	Pink sticker	Suspension	Air bag damaged/fully deflated – laden	07/03/2019
13/12/2018	107324	PNIQ51	7B837	Trailer/caravan	Fail	5, 3	Pink sticker	Brakes	Air brake pipe, hose, connector or component leaking - audible air leak from a pipe, hose, connector or component.	29/04/2019
13/12/2018	107324	PNIQ51	7B837	Trailer/caravan	Fail	5, 3	Green sticker	Ball-race Turntables	Ball-race turntable bolts loose – up to 25% (max 3)	29/04/2019
13/12/2018	107324	PNIQ51	PHL25	Goods van/truck/utility	Pass	5, 3	No Action			02/05/2019
18/12/2018	107332	PNIQ51	8K642	Trailer/caravan	Pass	5, 3	No Action			29/05/2019
18/12/2018	107332	PNIQ51	PHL13	Goods van/truck/utility	Pass	5, 3	No Action			15/06/2019
19/12/2018	123569	RBC411	PHL30	Goods van/truck/utility	Fail	5, 3	Green 2 action	Fluid Leaks	Fluid leaks other	04/03/2019
19/12/2018	123569	RBC411	R443P	Trailer/caravan	Fail	5, 3	Pink sticker	Suspension	Suspension component not fitted/not securely fitted	02/03/2019
19/12/2018	123569	RBC411	R443P	Trailer/caravan	Fail	5, 3	Green 2 action	Wheels and Tyres	A tyre is damaged/imbedded object – operation not affected	02/03/2019
05/02/2019	123590	RBC411	K898F	Trailer/caravan	Fail	6, 3	Green 2 action	Lighting	A rear tail lamp is not operating, damaged or fully obscured	13/04/2019
05/02/2019	123590	RBC411	K898F	Trailer/caravan	Fail	6, 3	Green 2 action	Suspension	Axle locating device loose – includes loose “U” bolts	13/04/2019
05/02/2019	123590	RBC411	PHL05	Goods van/truck/utility	Fail	6, 3	Green 2 action	Lighting	A headlamp is damaged failure is imminent or light output on either side is not approx equal	02/05/2019
08/02/2019	123597	RBC411	P352C	Trailer/caravan	Pass	5, 3	No Action			10/09/2019
08/02/2019	123597	RBC411	PHL15	Goods van/truck/utility	Pass	5, 3	No Action			01/09/2019
14/02/2019	107362	PNIQ51	7P447	Trailer/caravan	Pass	5, 3	No Action			01/07/2019
14/02/2019	107362	PNIQ51	PHL37	Goods van/truck/utility	Pass	5, 3	No Action			01/07/2019
19/02/2019	126815	RBC411	7K728	Trailer/caravan	Pass	5, 3	No Action			07/06/2019
19/02/2019	126815	RBC411	PHL38	Goods van/truck/utility	Pass	5, 3	No Action			22/05/2019
19/02/2019	126816	RBC411	PHL01	Goods van/truck/utility	Pass	5, 3	No Action			04/05/2019
19/02/2019	126816	RBC411	Z760L	Trailer/caravan	Pass	5, 3	No Action			23/04/2019
20/02/2019	126823	RBC411	PHL06	Goods van/truck/utility	Fail	5, 3	Green 2 action	Lighting	Side marker lamp not operational, not secure, damaged or obscured	26/05/2019

Insp Date	CVIR Sheet #	QID	Plate	Vehicle Types Meaning	Insp Result	Insp Lvl	Fault Action	Fault Category	Fault desc	COF Expiry Date
20/02/2019	126823	RBC411	Z505Y	Trailer/caravan	Pass	5, 3	No Action			21/05/2019
21/02/2019	126828	RBC411	PHL35	Goods van/truck/utility	Pass	5, 3	No Action			17/05/2019
21/02/2019	126828	RBC411	T672A	Trailer/caravan	Fail	5, 3	Pink sticker	Brakes	Air brake pipe, hose, connector or component leaking - audible air leak from a pipe, hose, connector or component.	08/05/2019
21/02/2019	126829	RBC411	PHL02	Goods van/truck/utility	Pass	5, 3	No Action			08/04/2019
21/02/2019	126829	RBC411	R177T	Trailer/caravan	Fail	5, 3	Pink sticker	Lighting	No stop lamps fitted, no stop lamps working, are excessively damaged or fully obscured. Single vehicle or rear unit of combo	08/04/2019
21/02/2019	126829	RBC411	R177T	Trailer/caravan	Fail	5, 3	Pink sticker	Lighting	Whole indicator system does not operate	08/04/2019
21/02/2019	126829	RBC411	R177T	Trailer/caravan	Fail	5, 3	Green 2 action	Lighting	Side marker lamp not operational, not secure, damaged or obscured	08/04/2019
21/02/2019	126829	RBC411	R177T	Trailer/caravan	Fail	5, 3	Green 2 action	Lighting	A rear tail lamp is not operating, damaged or fully obscured	08/04/2019
27/02/2019	126839	RBC411	4Z305	Trailer/caravan	Fail	5, 3	Green sticker	Suspension	Shock absorber missing, damaged or leaking excessively (wet or dripping)	26/07/2019
27/02/2019	126839	RBC411	PHL26	Goods van/truck/utility	Pass	5, 3	No Action			26/07/2019
28/02/2019	107378	PNIQ51	9Z506	Trailer/caravan	Pass	5, 3	No Action			09/06/2019
28/02/2019	107378	PNIQ51	PHL41	Goods van/truck/utility	Pass	5, 3	No Action			17/05/2019
04/03/2019	126843	RBC411	7U983	Trailer/caravan	Pass	5, 3	No Action			26/03/2019
04/03/2019	126843	RBC411	PHL40	Goods van/truck/utility	Pass	5, 3	No Action			03/04/2019
25/03/2019	142401	RBC411	PHL16	Goods van/truck/utility	Pass	5, 3	No Action			25/07/2019
25/03/2019	142401	RBC411	S25E	Trailer/caravan	Pass	5, 3	No Action			25/07/2019
26/03/2019	137249	RSJ147	9Z506	Trailer/caravan	Pass	5, 3	No Action			09/06/2019
26/03/2019	137249	RSJ147	PHL41	Goods van/truck/utility	Pass	5, 3	No Action			17/05/2019
26/03/2019	141801	RSJ147	PHL20	Goods van/truck/utility	Pass	5, 3	No Action			07/09/2019
26/03/2019	141801	RSJ147	T674A	Trailer/caravan	Fail	5, 3	Pink sticker	Wheels and Tyres	A tyre is damaged – operation affected and/or failure imminent	07/09/2019
27/03/2019	136324	PNIQ51	9Z511	Trailer/caravan	Fail	5, 3	Pink sticker	Brakes	Air tank mounts broken – tanks insecure	10/07/2019
27/03/2019	136324	PNIQ51	PHL42	Goods van/truck/utility	Pass	5, 3	No Action			10/07/2019
27/03/2019	136326	WHG676	7B837	Trailer/caravan	Fail	5, 3	Green sticker	Ball-race Turntables	Ball-race turntable bolts loose – up to 25% (max 3)	29/04/2019
27/03/2019	136326	WHG676	PHL25	Goods van/truck/utility	Pass	5, 3	No Action			02/05/2019
27/03/2019	136101	PNIQ51	8K642	Trailer/caravan	Pass	5, 3	No Action			29/05/2019

Insp Date	CVIR Sheet #	QID	Plate	Vehicle Types Meaning	Insp Result	Insp Lvl	Fault Action	Fault Category	Fault desc	COF Expiry Date
27/03/2019	136101	PNIQ51	PHL13	Goods van/truck/utility	Pass	5, 3	No Action			15/06/2019
27/03/2019	141821	RSJ147	PHL30	Goods van/truck/utility	Fail	5, 3	Green sticker	Brakes	Stroke of brake chamber exceeds manufacturer's limit - service brake performance doesn't meet legal requirements	04/09/2019
27/03/2019	141821	RSJ147	R443P	Trailer/caravan	Pass	5, 3	No Action			02/09/2019
01/04/2019	136110	PNIQ51	6Y910	Trailer/caravan	Pass	5, 3	No Action			19/09/2019
01/04/2019	136110	PNIQ51	PHL36	Goods van/truck/utility	Pass	5, 3	No Action			14/09/2019
05/04/2019	142423	RBC411	PHL41	Goods van/truck/utility	Pass	3	No Action			17/05/2019
11/04/2019	142437	RBC411	PHL37	Goods van/truck/utility	Pass	5, 3	No Action			01/07/2019
10/05/2019	136118	PNIQ51	9Z516	Trailer/caravan	Pass	5, 3	No Action			24/07/2019
10/05/2019	136118	PNIQ51	PHL43	Goods van/truck/utility	Pass	5, 3	No Action			24/07/2019
16/05/2019	136121	PNIQ51	13Q38	Trailer/caravan	Pass	5, 3	No Action			04/08/2019
16/05/2019	136121	PNIQ51	PHL10	Goods van/truck/utility	Fail	5, 3	Pink sticker	Vision	Windscreen not fitted or damaged in CVA compromising driver's vision/structural strength/windscreen wiper operation	03/08/2019
16/05/2019	136123	PNIQ51	7P447	Trailer/caravan	Pass	5, 3	No Action			01/07/2019
16/05/2019	136123	PNIQ51	PHL37	Goods van/truck/utility	Pass	5, 3	No Action			01/07/2019
17/05/2019	150763	BWD335	8A839	Trailer/caravan	Pass	5, 3	No Action			19/09/2019
17/05/2019	150763	BWD335	PHL39	Goods van/truck/utility	Pass	5, 3	No Action			29/09/2019
21/05/2019	146922	RBC411	PHL02	Goods van/truck/utility	Pass	3	No Action			08/10/2019
21/05/2019	146922	RBC411	R177T	Trailer/caravan	Pass	3	No Action			08/10/2019
22/05/2019	150780	BWD335	6F838	Trailer/caravan	Pass	5, 3	No Action			15/07/2019
22/05/2019	150780	BWD335	PHL28	Goods van/truck/utility	Pass	5, 3	No Action			15/07/2019
23/05/2019	150773	BWD335	PHL27	Goods van/truck/utility	Fail	5, 3	Green sticker	Mudguards	One mudguard missing/does not comply or a mudflap not fitted to a twin tyred axle	21/12/2019
23/05/2019	150773	BWD335	PHL27	Goods van/truck/utility	Fail	5, 3	Green sticker	Wheels and Tyres	Tread insufficient, any other tyres – not operated in rain	21/12/2019
27/05/2019	136136	PNIQ51	K898F	Trailer/caravan	Pass	5, 3	No Action			13/10/2019
27/05/2019	136136	PNIQ51	PHL05	Goods van/truck/utility	Fail	5, 3	Green 2 action	Fluid Leaks	Fluid leaks other	31/10/2019
27/05/2019	136139	PNIQ51	9C103	Trailer/caravan	Pass	5, 3	No Action			01/08/2019
27/05/2019	136139	PNIQ51	PHL17	Goods van/truck/utility	Pass	5, 3	No Action			01/08/2019
29/05/2019	136143	PNIQ51	PHL19	Goods van/truck/utility	Pass	5, 3	No Action			30/10/2019
29/05/2019	136143	PNIQ51	S597H	Trailer/caravan	Pass	5, 3	No Action			30/10/2019

Insp Date	CVIR Sheet #	QID	Plate	Vehicle Types Meaning	Insp Result	Insp Lvl	Fault Action	Fault Category	Fault desc	COF Expiry Date
29/05/2019	136145	PNIQ51	GDU506	Goods van/truck/utility	Fail	5, 3	Green 2 action	Vision	Windscreen wiper not fitted, not operational, loose or damaged	06/06/2019
05/06/2019	150784	BWD335	PHL01	Goods van/truck/utility	Pass	5, 3	No Action			04/11/2019
05/06/2019	150784	BWD335	Z760L	Trailer/caravan	Pass	5, 3	No Action			23/10/2019
21/06/2019	147695	PNIQ51	PHL35	Goods van/truck/utility	Pass	5, 3	No Action			17/11/2019
27/06/2019	152251	RBC411	PHL25	Goods van/truck/utility	Pass	3	No Action			02/11/2019
02/07/2019	158561	PNIQ51	9Z506	Trailer/caravan	Pass	5, 3	No Action			09/12/2019
02/07/2019	158561	PNIQ51	PHL41	Goods van/truck/utility	Pass	5, 3	No Action			17/11/2019
04/07/2019	152263	RBC411	J816F	Trailer/caravan	Fail	5, 3	Pink sticker	Cab, Chassis and Body	Chassis rail, cross members, deck attachments, or cab and body attachments damaged - risk of failure/unsafe operation, vehicle loaded	08/01/2020
04/07/2019	152263	RBC411	J816F	Trailer/caravan	Fail	5, 3	Green 2 action	Lighting	A direction indicator lamp works intermittently and flickers when tapped.	08/01/2020
04/07/2019	152263	RBC411	PHL08	Goods van/truck/utility	Pass	5, 3	No Action			30/11/2019

Total Vehicles Inspected:	212	Fault Action	Total	Vehicle Action	Total
Total Faults:	105	Pink sticker	31	Compliance	11
Total Fails:	78	Green sticker	23	No Action	133
Total Passes:	134	Green 2 action	51	Pink	2
Total Fault Actions:	105	No Action	134	Roadside Remedy	18
Avg No Faults per Vehicle:	0.50		239	Verbal Direction	48
Avg No. Faults per Failed Vehicle:	1.35				212

### Inspections by Driver

DL Number: s9(2)(a)

Driver: s9(2)(a)

Insp Date	CVIR Sheet #	QID	Plate	Vehicle Types Meaning	Insp Result	Insp Lvl	Fault Action	Fault Category	Fault desc	COF Expiry Date
08/02/2018	843246	BLDA87	PHL31	Goods van/truck/utility	Fail	5	Green 2 action	Lighting	A headlamp is damaged failure is imminent or light output on either side is not approx equal	18/06/2018
08/02/2018	843246	BLDA87	W970G	Trailer/caravan	Pass	5	No Action			18/06/2018
30/10/2018	105582	BWD335	PHL12	Goods van/truck/utility	Pass	5, 3	No Action			24/04/2019

DL Number: s9(2)(a)

Driver: s9(2)(a)

Insp Date	CVIR Sheet #	QID	Plate	Vehicle Types Meaning	Insp Result	Insp Lvl	Fault Action	Fault Category	Fault desc	COF Expiry Date
15/11/2018	114567	RBC411	PHL34	Goods van/truck/utility	Pass	5, 3	No Action			27/02/2019
15/11/2018	114567	RBC411	Y951K	Trailer/caravan	Fail	5, 3	Green sticker	Brakes	Air leak low air pressure >30 seconds	28/02/2019
15/11/2018	114567	RBC411	Y951K	Trailer/caravan	Fail	5, 3	Green sticker	Brakes	Reservoir/master cylinder/servo unit leaks, or is loose/otherwise damaged or worn	28/02/2019

DL Number: s9(2)(a)

Driver: s9(2)(a)

Insp Date	CVIR Sheet #	QID	Plate	Vehicle Types Meaning	Insp Result	Insp Lvl	Fault Action	Fault Category	Fault desc	COF Expiry Date
04/07/2019	152263	RBC411	J816F	Trailer/caravan	Fail	5, 3	Pink sticker	Cab, Chassis and Body	Chassis rail, cross members, deck attachments, or cab and body attachments damaged - risk of failure/unsafe operation, vehicle loaded	08/01/2020
04/07/2019	152263	RBC411	J816F	Trailer/caravan	Fail	5, 3	Green 2 action	Lighting	A direction indicator lamp works intermittently and flickers when tapped.	08/01/2020
04/07/2019	152263	RBC411	PHL08	Goods van/truck/utility	Pass	5, 3	No Action			30/11/2019

DL Number: s9(2)(a)

Driver: s9(2)(a)

Insp Date	CVIR Sheet #	QID	Plate	Vehicle Types Meaning	Insp Result	Insp Lvl	Fault Action	Fault Category	Fault desc	COF Expiry Date
21/06/2019	147695	PNIQ51	PHL35	Goods van/truck/utility	Pass	5, 3	No Action			17/11/2019

DL Number: s9(2)(a)

Driver: s9(2)(a)

Insp Date	CVIR Sheet #	QID	Plate	Vehicle Types Meaning	Insp Result	Insp Lvl	Fault Action	Fault Category	Fault desc	COF Expiry Date
13/11/2018	114496	RBC411	PHL35	Goods van/truck/utility	Fail	5, 3	Green sticker	Brakes	Spring brake/electric brake control for parking brakes not protected from inadvertent release	17/05/2019
13/11/2018	114496	RBC411	T672A	Trailer/caravan	Pass	5, 3	No Action			08/05/2019
21/02/2019	126828	RBC411	PHL35	Goods van/truck/utility	Pass	5, 3	No Action			17/05/2019
21/02/2019	126828	RBC411	T672A	Trailer/caravan	Fail	5, 3	Pink sticker	Brakes	Air brake pipe, hose, connector or component leaking - audible air leak from a pipe, hose, connector or component.	08/05/2019

DL Number: s9(2)(a)

Driver: s9(2)(a)

Insp Date	CVIR Sheet #	QID	Plate	Vehicle Types Meaning	Insp Result	Insp Lvl	Fault Action	Fault Category	Fault desc	COF Expiry Date
25/03/2019	142401	RBC411	PHL16	Goods van/truck/utility	Pass	5, 3	No Action			25/07/2019
25/03/2019	142401	RBC411	S25E	Trailer/caravan	Pass	5, 3	No Action			25/07/2019

DL Number: s9(2)(a)

Driver: s9(2)(a)

Insp Date	CVIR Sheet #	QID	Plate	Vehicle Types Meaning	Insp Result	Insp Lvl	Fault Action	Fault Category	Fault desc	COF Expiry Date
19/10/2017	833650	RBC411	K438A	Trailer/caravan	Fail	3	Pink sticker	Wheels and Tyres	A tyre is damaged – operation affected and/or failure imminent	17/11/2017
19/10/2017	833650	RBC411	PHL04	Goods van/truck/utility	Fail	3	Green 2 action	Load Anchorage	Bolster not securely fitted or attachment is damaged – no immediate risk of failure	02/11/2017

Released under the Official Information Act 1982

DL Number: s9(2)(a)

Driver: s9(2)(a)

Insp Date	CVIR Sheet #	QID	Plate	Vehicle Types Meaning	Insp Result	Insp Lvl	Fault Action	Fault Category	Fault desc	COF Expiry Date
04/10/2017	832202	GGI670	J880M	Trailer/caravan	Fail	5, 3	Pink sticker	Wheels and Tyres	A tyre is damaged – operation affected and/or failure imminent	22/12/2017
04/10/2017	832202	GGI670	PHL29	Goods van/truck/utility	Pass	5, 3	No Action			21/12/2017
11/05/2018	850731	BLDA87	PHL29	Goods van/truck/utility	Pass	5	No Action			21/06/2018
11/05/2018	850731	BLDA87	U789M	Trailer/caravan	Pass	5	No Action			21/06/2018
14/11/2018	117929	JB227	PHL18	Goods van/truck/utility	Pass	5, 3	No Action			08/05/2019
14/11/2018	117929	JB227	R179F	Trailer/caravan	Pass	5, 3	No Action			24/05/2019

DL Number: s9(2)(a)

Driver: s9(2)(a)

Insp Date	CVIR Sheet #	QID	Plate	Vehicle Types Meaning	Insp Result	Insp Lvl	Fault Action	Fault Category	Fault desc	COF Expiry Date
15/11/2018	117173	WHG676	4Z305	Trailer/caravan	Pass	5, 3	No Action			01/02/2019
15/11/2018	117173	WHG676	PHL26	Goods van/truck/utility	Pass	5, 3	No Action			01/02/2019
26/11/2018	114589	RBC411	4Z305	Trailer/caravan	Pass	5, 3	No Action			01/02/2019
26/11/2018	114589	RBC411	PHL26	Goods van/truck/utility	Pass	5, 3	No Action			01/02/2019
12/12/2018	107316	PNIQ51	4Z305	Trailer/caravan	Pass	5, 3	No Action			01/02/2019
12/12/2018	107316	PNIQ51	PHL26	Goods van/truck/utility	Pass	5, 3	No Action			01/02/2019
27/02/2019	126839	RBC411	4Z305	Trailer/caravan	Fail	5, 3	Green sticker	Suspension	Shock absorber missing, damaged or leaking excessively (wet or dripping)	26/07/2019
27/02/2019	126839	RBC411	PHL26	Goods van/truck/utility	Pass	5, 3	No Action			26/07/2019



DL Number: s9(2)(a)

Driver: s9(2)(a)

Insp Date	CVIR Sheet #	QID	Plate	Vehicle Types Meaning	Insp Result	Insp Lvl	Fault Action	Fault Category	Fault desc	COF Expiry Date
03/10/2017	830350	RBC411	7B837	Trailer/caravan	Fail	5, 3	Green 2 action	Cab, Chassis and Body	Load containment structure damaged or not securely fitted - risk of failure, vehicle unloaded (includes cab guard)	28/10/2017
03/10/2017	830350	RBC411	PHL25	Goods van/truck/utility	Pass	5, 3	No Action			02/11/2017
13/12/2018	107324	PNIQ51	7B837	Trailer/caravan	Fail	5, 3	Pink sticker	Brakes	Air brake pipe, hose, connector or component leaking - audible air leak from a pipe, hose, connector or component.	29/04/2019
13/12/2018	107324	PNIQ51	7B837	Trailer/caravan	Fail	5, 3	Green sticker	Ball-race Turntables	Ball-race turntable bolts loose - up to 25% (max 3)	29/04/2019
13/12/2018	107324	PNIQ51	PHL25	Goods van/truck/utility	Pass	5, 3	No Action			02/05/2019
27/03/2019	136326	WHG676	7B837	Trailer/caravan	Fail	5, 3	Green sticker	Ball-race Turntables	Ball-race turntable bolts loose - up to 25% (max 3)	29/04/2019
27/03/2019	136326	WHG676	PHL25	Goods van/truck/utility	Pass	5, 3	No Action			02/05/2019
27/06/2019	152251	RBC411	PHL25	Goods van/truck/utility	Pass	3	No Action			02/11/2019

DL Number: s9(2)(a)

Driver: s9(2)(a)

Insp Date	CVIR Sheet #	QID	Plate	Vehicle Types Meaning	Insp Result	Insp Lvl	Fault Action	Fault Category	Fault desc	COF Expiry Date
03/10/2017	833892	PJAT18	M829A	Trailer/caravan	Fail	5, 3	Pink sticker	Suspension	Leaf spring or coil spring broken, missing or seriously damaged.	03/04/2018
03/10/2017	833892	PJAT18	PHL12	Goods van/truck/utility	Fail	5, 3	Pink sticker	Brakes	Park brake actuator missing/not operational/does not lock into position, remains applied when released, is not securely fastened & may detach. Risk of inadvertent release	24/10/2017
20/06/2018	857357	RBC411	PHL32	Goods van/truck/utility	Pass	3	No Action			26/08/2018
12/11/2018	117905	JB227	PHL32	Goods van/truck/utility	Fail	5, 3	Green sticker	Exhaust System	Exhaust system not effective, loose, leaks or excessive noise	26/02/2019
12/11/2018	117905	JB227	W198L	Trailer/caravan	Fail	5, 3	Pink sticker	Brakes	ABS/EBS system is not operating - Combination vehicle	21/02/2019
27/05/2019	136139	PNIQ51	9C103	Trailer/caravan	Pass	5, 3	No Action			01/08/2019
27/05/2019	136139	PNIQ51	PHL17	Goods van/truck/utility	Pass	5, 3	No Action			01/08/2019

DL Number: s9(2)(a)

Driver: s9(2)(a)

Insp Date	CVIR Sheet #	QID	Plate	Vehicle Types Meaning	Insp Result	Insp Lvl	Fault Action	Fault Category	Fault desc	COF Expiry Date
01/08/2017	822421	RBC411	H469A	Trailer/caravan	Fail	5, 3	Green 2 action	Brakes	Air leaks any other system	03/12/2017
01/08/2017	822421	RBC411	PHL07	Goods van/truck/utility	Pass	5, 3	No Action			16/12/2017
11/10/2017	833637	RBC411	H469A	Trailer/caravan	Fail	3	Green 2 action	Brakes	Air leaks any other system	03/12/2017
11/10/2017	833637	RBC411	PHL07	Goods van/truck/utility	Pass	3	No Action			16/12/2017
15/11/2018	121785	WDJ177	9Z506	Trailer/caravan	Pass	5, 3	No Action			09/06/2019
15/11/2018	121785	WDJ177	PHL41	Goods van/truck/utility	Pass	5, 3	No Action			17/05/2019
28/02/2019	107378	PNIQ51	9Z506	Trailer/caravan	Pass	5, 3	No Action			09/06/2019
28/02/2019	107378	PNIQ51	PHL41	Goods van/truck/utility	Pass	5, 3	No Action			17/05/2019
26/03/2019	137249	RSJ147	9Z506	Trailer/caravan	Pass	5, 3	No Action			09/06/2019
26/03/2019	137249	RSJ147	PHL41	Goods van/truck/utility	Pass	5, 3	No Action			17/05/2019
05/04/2019	142423	RBC411	PHL41	Goods van/truck/utility	Pass	3	No Action			17/05/2019
02/07/2019	158561	PNIQ51	9Z506	Trailer/caravan	Pass	5, 3	No Action			09/12/2019
02/07/2019	158561	PNIQ51	PHL41	Goods van/truck/utility	Pass	5, 3	No Action			17/11/2019

DL Number: s9(2)(a)

Driver: s9(2)(a)

Insp Date	CVIR Sheet #	QID	Plate	Vehicle Types Meaning	Insp Result	Insp Lvl	Fault Action	Fault Category	Fault desc	COF Expiry Date
11/09/2017	830316	RBC411	PHL01	Goods van/truck/utility	Pass	3	No Action			04/11/2017

Released under the Official Information Act 1982

DL Number: s9(2)(a)

Driver: s9(2)(a)

Insp Date	CVIR Sheet #	QID	Plate	Vehicle Types Meaning	Insp Result	Insp Lvl	Fault Action	Fault Category	Fault desc	COF Expiry Date
22/08/2017	826921	RBC411	K898F	Trailer/caravan	Pass	5, 3	No Action			13/10/2017
22/08/2017	826921	RBC411	PHL05	Goods van/truck/utility	Fail	5, 3	Green 2 action	Lighting	One direction Indicator lamp not working	08/11/2017
27/09/2018	097707	RBC411	PHL05	Goods van/truck/utility	Fail	5, 3	Green 2 action	Lighting	One required headlamp is not fitted, not securely attached or is not operational	02/11/2018
26/10/2018	105572	BWD335	K898F	Trailer/caravan	Fail	5, 3	Pink sticker	Lighting	No stop lamps fitted, no stop lamps working, are excessively damaged or fully obscured. Single vehicle or rear unit of combo	13/04/2019
26/10/2018	105572	BWD335	PHL05	Goods van/truck/utility	Pass	5, 3	No Action			02/05/2019
13/11/2018	114499	RBC411	K898F	Trailer/caravan	Fail	5, 3	Green 2 action	Load Anchorage	Bolster not securely fitted or attachment is damaged – no immediate risk of failure	13/04/2019
13/11/2018	114499	RBC411	PHL05	Goods van/truck/utility	Fail	5, 3	Green sticker	Brakes	Spring brake/electric brake control for parking brakes not protected from inadvertent release	02/05/2019
13/11/2018	114499	RBC411	PHL05	Goods van/truck/utility	Fail	5, 3	Pink sticker	Wheels and Tyres	Wheel nuts loose/missing or studs damaged/missing - safety risk	02/05/2019
05/02/2019	123590	RBC411	K898F	Trailer/caravan	Fail	6, 3	Green 2 action	Lighting	A rear tail lamp is not operating, damaged or fully obscured	13/04/2019
05/02/2019	123590	RBC411	K898F	Trailer/caravan	Fail	6, 3	Green 2 action	Suspension	Axle locating device loose – includes loose "U" bolts	13/04/2019
05/02/2019	123590	RBC411	PHL05	Goods van/truck/utility	Fail	6, 3	Green 2 action	Lighting	A headlamp is damaged failure is imminent or light output on either side is not approx equal	02/05/2019
27/05/2019	136136	PNIQ51	K898F	Trailer/caravan	Pass	5, 3	No Action			13/10/2019
27/05/2019	136136	PNIQ51	PHL05	Goods van/truck/utility	Fail	5, 3	Green 2 action	Fluid Leaks	Fluid leaks other	31/10/2019

Released under the Official Information Act 1982

DL Number: s9(2)(a)

Driver: s9(2)(a)

Insp Date	CVIR Sheet #	QID	Plate	Vehicle Types Meaning	Insp Result	Insp Lvl	Fault Action	Fault Category	Fault desc	COF Expiry Date
07/07/2018	861259	RBC411	7P447	Trailer/caravan	Pass	3	No Action			06/01/2019
07/07/2018	861259	RBC411	PHL37	Goods van/truck/utility	Pass	3	No Action			06/01/2019
13/07/2018	861267	RBC411	PHL37	Goods van/truck/utility	Fail	3	Green sticker	Mudguards	One mudguard missing/does not comply or a mudflap not fitted to a twin tyred axle	06/01/2019
14/02/2019	107362	PNIQ51	7P447	Trailer/caravan	Pass	5, 3	No Action			01/07/2019
14/02/2019	107362	PNIQ51	PHL37	Goods van/truck/utility	Pass	5, 3	No Action			01/07/2019
11/04/2019	142437	RBC411	PHL37	Goods van/truck/utility	Pass	5, 3	No Action			01/07/2019
16/05/2019	136123	PNIQ51	7P447	Trailer/caravan	Pass	5, 3	No Action			01/07/2019
16/05/2019	136123	PNIQ51	PHL37	Goods van/truck/utility	Pass	5, 3	No Action			01/07/2019

DL Number: s9(2)(a)

Driver: s9(2)(a)

Insp Date	CVIR Sheet #	QID	Plate	Vehicle Types Meaning	Insp Result	Insp Lvl	Fault Action	Fault Category	Fault desc	COF Expiry Date
17/05/2019	150763	BWD335	8A839	Trailer/caravan	Pass	5, 3	No Action			19/09/2019
17/05/2019	150763	BWD335	PHL39	Goods van/truck/utility	Pass	5, 3	No Action			29/09/2019

DL Number: s9(2)(a)

Driver: s9(2)(a)

Insp Date	CVIR Sheet #	QID	Plate	Vehicle Types Meaning	Insp Result	Insp Lvl	Fault Action	Fault Category	Fault desc	COF Expiry Date
08/02/2019	123597	RBC411	P352C	Trailer/caravan	Pass	5, 3	No Action			10/09/2019
08/02/2019	123597	RBC411	PHL15	Goods van/truck/utility	Pass	5, 3	No Action			01/09/2019

Released under the Official Information Act 1982

DL Number: s9(2)(a)

Driver: s9(2)(a)

Insp Date	CVIR Sheet #	QID	Plate	Vehicle Types Meaning	Insp Result	Insp Lvl	Fault Action	Fault Category	Fault desc	COF Expiry Date
04/10/2017	830360	RBC411	K239N	Trailer/caravan	Pass	5, 3	No Action			30/03/2018
04/10/2017	830360	RBC411	PHL10	Goods van/truck/utility	Pass	5, 3	No Action			30/03/2018
30/11/2017	837267	RBC411	K239N	Trailer/caravan	Fail	5, 3	Green 2 action	Lighting	Side marker lamp not operational, not secure, damaged or obscured	30/03/2018
30/11/2017	837267	RBC411	PHL10	Goods van/truck/utility	Fail	5, 3	Green 2 action	Lighting	One or more front park lamps not operational (anytime)	30/03/2018
05/12/2017	839682	RBC411	PHL10	Goods van/truck/utility	Fail	3	Green 2 action	Lighting	One or more front park lamps not operational (anytime)	30/03/2018

DL Number: s9(2)(a)

Driver: s9(2)(a)

Insp Date	CVIR Sheet #	QID	Plate	Vehicle Types Meaning	Insp Result	Insp Lvl	Fault Action	Fault Category	Fault desc	COF Expiry Date
03/12/2018	123554	RBC411	PHL09	Goods van/truck/utility	Pass	5, 3	No Action			25/03/2019
03/12/2018	123554	RBC411	Z745L	Trailer/caravan	Pass	5, 3	No Action			24/03/2019

DL Number: s9(2)(a)

Driver: s9(2)(a)

Insp Date	CVIR Sheet #	QID	Plate	Vehicle Types Meaning	Insp Result	Insp Lvl	Fault Action	Fault Category	Fault desc	COF Expiry Date
05/10/2017	834833	NRY683	PHL35	Goods van/truck/utility	Fail	5, 3	Green 2 action	Lighting	A headlamp is damaged failure is imminent or light output on either side is not approx equal	17/11/2017
05/10/2017	834833	NRY683	T672A	Trailer/caravan	Fail	5, 3	Green 2 action	PSV Wheels and Tyres	Tread in dual set 1 tyre below minimum	08/11/2017
03/05/2018	854337	BWD335	PHL18	Goods van/truck/utility	Pass	5, 3	No Action			08/11/2018

DL Number: s9(2)(a)

Driver: s9(2)(a)

Insp Date	CVIR Sheet #	QID	Plate	Vehicle Types Meaning	Insp Result	Insp Lvl	Fault Action	Fault Category	Fault desc	COF Expiry Date
11/08/2017	822440	RBC411	PHL13	Goods van/truck/utility	Fail	5, 3	Green 2 action	Brakes	Air leaks any other system	30/01/2018

DL Number: s9(2)(a)

Driver: s9(2)(a)

Insp Date	CVIR Sheet #	QID	Plate	Vehicle Types Meaning	Insp Result	Insp Lvl	Fault Action	Fault Category	Fault desc	COF Expiry Date
14/11/2018	114558	RBC411	N102T	Trailer/caravan	Fail	5, 3	Green 2 action	Lighting	One direction Indicator lamp not working	30/04/2019
14/11/2018	114558	RBC411	PHL14	Goods van/truck/utility	Fail	5, 3	Green sticker	Brakes	Spring brake/electric brake control for parking brakes not protected from inadvertent release	30/04/2019
14/11/2018	114558	RBC411	PHL14	Goods van/truck/utility	Fail	5, 3	Green sticker	Exhaust System	Exhaust system not effective, loose, leaks or excessive noise	30/04/2019
14/11/2018	114558	RBC411	PHL14	Goods van/truck/utility	Fail	5, 3	Green 2 action	Fluid Leaks	Fluid leaks other	30/04/2019
27/03/2019	141821	RSJ147	PHL30	Goods van/truck/utility	Fail	5, 3	Green sticker	Brakes	Stroke of brake chamber exceeds manufacturer's limit - service brake performance doesn't meet legal requirements	04/09/2019
27/03/2019	141821	RSJ147	R443P	Trailer/caravan	Pass	5, 3	No Action			02/09/2019

DL Number: s9(2)(a)

Driver: s9(2)(a)

Insp Date	CVIR Sheet #	QID	Plate	Vehicle Types Meaning	Insp Result	Insp Lvl	Fault Action	Fault Category	Fault desc	COF Expiry Date
03/10/2017	832193	GGI670	PHL23	Goods van/truck/utility	Fail	5, 3	Green 2 action	Load Anchorage	Bolster not securely fitted or attachment is damaged – no immediate risk of failure	21/11/2017
03/10/2017	832193	GGI670	Q884L	Trailer/caravan	Fail	5, 3	Green sticker	Brakes	Stroke of brake chamber exceeds manufacturer's limit - service brake performance doesn't meet legal requirements	30/10/2017
17/05/2018	850732	BLDA87	PHL23	Goods van/truck/utility	Pass	5	No Action			21/11/2018
03/12/2018	114599	RBC411	PHL33	Goods van/truck/utility	Fail	5, 3	Green sticker	Brakes	Spring brake/electric brake control for parking brakes not protected from inadvertent release	03/04/2019
03/12/2018	114599	RBC411	PHL33	Goods van/truck/utility	Fail	5, 3	Green 2 action	Lighting	One required headlamp is not fitted, not securely attached or is not operational	03/04/2019

DL Number: s9(2)(a)

Driver: s9(2)(a)

Insp Date	CVIR Sheet #	QID	Plate	Vehicle Types Meaning	Insp Result	Insp Lvl	Fault Action	Fault Category	Fault desc	COF Expiry Date
16/08/2018	872864	RBC411	M829A	Trailer/caravan	Fail	3	Green 2 action	Lighting	One required rear reflector fitted, not securely fitted, colour other than red, anytime	03/10/2018
16/08/2018	872864	RBC411	PHL12	Goods van/truck/utility	Pass	3	No Action			24/10/2018
16/05/2019	136121	PNIQ51	13Q38	Trailer/caravan	Pass	5, 3	No Action			04/08/2019
16/05/2019	136121	PNIQ51	PHL10	Goods van/truck/utility	Fail	5, 3	Pink sticker	Vision	Windscreen not fitted or damaged in CVA compromising driver's vision/structural strength/windscreen wiper operation	03/08/2019

DL Number: s9(2)(a)

Driver: s9(2)(a)

Insp Date	CVIR Sheet #	QID	Plate	Vehicle Types Meaning	Insp Result	Insp Lvl	Fault Action	Fault Category	Fault desc	COF Expiry Date
16/04/2018	854940	RBC411	P352C	Trailer/caravan	Pass	3	No Action			20/09/2018
16/04/2018	854940	RBC411	PHL15	Goods van/truck/utility	Fail	3	Green 2 action	Load Anchorage	Bolster not securely fitted or attachment is damaged – no immediate risk of failure	01/09/2018

DL Number: s9(2)(a)

Driver: s9(2)(a)

Insp Date	CVIR Sheet #	QID	Plate	Vehicle Types Meaning	Insp Result	Insp Lvl	Fault Action	Fault Category	Fault desc	COF Expiry Date
21/05/2019	146922	RBC411	PHL02	Goods van/truck/utility	Pass	3	No Action			08/10/2019
21/05/2019	146922	RBC411	R177T	Trailer/caravan	Pass	3	No Action			08/10/2019

DL Number: s9(2)(a)

Driver: s9(2)(a)

Insp Date	CVIR Sheet #	QID	Plate	Vehicle Types Meaning	Insp Result	Insp Lvl	Fault Action	Fault Category	Fault desc	COF Expiry Date
08/09/2017	826958	RBC411	L402L	Trailer/caravan	Fail	3	Pink sticker	Lighting	All side marker lamps not operational (during darkness)	13/01/2018
08/09/2017	826958	RBC411	L402L	Trailer/caravan	Fail	3	Pink sticker	Lighting	A rear tail lamp is not operational (during darkness) no other rear right lamp operational	13/01/2018
08/09/2017	826958	RBC411	PHL11	Goods van/truck/utility	Pass	3	No Action			13/01/2018

DL Number: s9(2)(a)

Driver: s9(2)(a)

Insp Date	CVIR Sheet #	QID	Plate	Vehicle Types Meaning	Insp Result	Insp Lvl	Fault Action	Fault Category	Fault desc	COF Expiry Date
14/11/2018	117925	JBJ227	PHL23	Goods van/truck/utility	Pass	5, 3	No Action			21/05/2019
14/11/2018	117925	JBJ227	Q884L	Trailer/caravan	Fail	5, 3	Pink sticker	Suspension	Suspension component not fitted/not securely fitted	30/04/2019
14/11/2018	117925	JBJ227	Q884L	Trailer/caravan	Fail	5, 3	Green 2 action	Wheels and Tyres	Tyre not correctly inflated – operation/control not affected	30/04/2019

DL Number: s9(2)(a)

Driver: s9(2)(a)

Insp Date	CVIR Sheet #	QID	Plate	Vehicle Types Meaning	Insp Result	Insp Lvl	Fault Action	Fault Category	Fault desc	COF Expiry Date
29/05/2019	136143	PNIQ51	PHL19	Goods van/truck/utility	Pass	5, 3	No Action			30/10/2019
29/05/2019	136143	PNIQ51	S597H	Trailer/caravan	Pass	5, 3	No Action			30/10/2019

DL Number: s9(2)(a)

Driver: s9(2)(a)

Insp Date	CVIR Sheet #	QID	Plate	Vehicle Types Meaning	Insp Result	Insp Lvl	Fault Action	Fault Category	Fault desc	COF Expiry Date
05/09/2017	826949	RBC411	PHL35	Goods van/truck/utility	Pass	3	No Action			17/11/2017
05/09/2017	826949	RBC411	T672A	Trailer/caravan	Pass	3	No Action			08/11/2017

DL Number: s9(2)(a)

Driver: s9(2)(a)

Insp Date	CVIR Sheet #	QID	Plate	Vehicle Types Meaning	Insp Result	Insp Lvl	Fault Action	Fault Category	Fault desc	COF Expiry Date
22/07/2017	768999	ATY330	7P447	Trailer/caravan	Pass	5	No Action			12/01/2018
22/07/2017	768999	ATY330	PHL37	Goods van/truck/utility	Pass	5	No Action			20/01/2018

Released under the Official Information Act 1982



DL Number: s9(2)(a)

Driver: s9(2)(a)

Insp Date	CVIR Sheet #	QID	Plate	Vehicle Types Meaning	Insp Result	Insp Lvl	Fault Action	Fault Category	Fault desc	COF Expiry Date
03/10/2018	114451	RBC411	PHL30	Goods van/truck/utility	Pass	5, 3	No Action			04/03/2019
03/10/2018	114451	RBC411	R443P	Trailer/caravan	Fail	5, 3	Pink sticker	Load Anchorage	Sliding bolster – no locking mechanism	02/03/2019
19/12/2018	123569	RBC411	PHL30	Goods van/truck/utility	Fail	5, 3	Green 2 action	Fluid Leaks	Fluid leaks other	04/03/2019
19/12/2018	123569	RBC411	R443P	Trailer/caravan	Fail	5, 3	Pink sticker	Suspension	Suspension component not fitted/not securely fitted	02/03/2019
19/12/2018	123569	RBC411	R443P	Trailer/caravan	Fail	5, 3	Green 2 action	Wheels and Tyres	A tyre is damaged/imbedded object – operation not affected	02/03/2019

DL Number: s9(2)(a)

Driver: s9(2)(a)

Insp Date	CVIR Sheet #	QID	Plate	Vehicle Types Meaning	Insp Result	Insp Lvl	Fault Action	Fault Category	Fault desc	COF Expiry Date
04/10/2017	832115	GME708	7K728	Trailer/caravan	Pass	5, 3	No Action			21/12/2017
04/10/2017	832115	GME708	PHL38	Goods van/truck/utility	Pass	5, 3	No Action			22/11/2017
19/02/2019	126815	RBC411	7K728	Trailer/caravan	Pass	5, 3	No Action			07/06/2019
19/02/2019	126815	RBC411	PHL38	Goods van/truck/utility	Pass	5, 3	No Action			22/05/2019

DL Number: s9(2)(a)

Driver: s9(2)(a)

Insp Date	CVIR Sheet #	QID	Plate	Vehicle Types Meaning	Insp Result	Insp Lvl	Fault Action	Fault Category	Fault desc	COF Expiry Date
27/02/2018	854254	BWD335	PHL06	Goods van/truck/utility	Pass	5, 3	No Action			26/05/2018
27/02/2018	854254	BWD335	Z505Y	Trailer/caravan	Pass	5, 3	No Action			21/05/2018
08/11/2018	114485	RBC411	PHL06	Goods van/truck/utility	Pass	5, 3	No Action			26/11/2018
08/11/2018	114485	RBC411	Z505Y	Trailer/caravan	Pass	5, 3	No Action			21/11/2018

DL Number: s9(2)(a)

Driver: s9(2)(a)

Insp Date	CVIR Sheet #	QID	Plate	Vehicle Types Meaning	Insp Result	Insp Lvl	Fault Action	Fault Category	Fault desc	COF Expiry Date
01/11/2017	837227	RBC411	PHL36	Goods van/truck/utility	Fail	3	Green sticker	Lighting	Direction indicator lamp is damaged, fully obscured or output affected/failure imminent or is not securely fitted (detachment is imminent)	30/03/2018
18/01/2018	837646	BLDA87	6Y910	Trailer/caravan	Pass	5	No Action			18/01/2018
18/01/2018	837646	BLDA87	PHL36	Goods van/truck/utility	Pass	5	No Action			18/01/2018
13/11/2018	105599	BWD335	6Y910	Trailer/caravan	Fail	5, 3	Green 2 action	Brakes	Suzie coil hose does not comply, support spring missing/ineffective	19/03/2019
13/11/2018	105599	BWD335	PHL36	Goods van/truck/utility	Pass	5, 3	No Action			14/03/2019
01/04/2019	136110	PNIQ51	6Y910	Trailer/caravan	Pass	5, 3	No Action			19/09/2019
01/04/2019	136110	PNIQ51	PHL36	Goods van/truck/utility	Pass	5, 3	No Action			14/09/2019

DL Number: s9(2)(a)

Driver: s9(2)(a)

Insp Date	CVIR Sheet #	QID	Plate	Vehicle Types Meaning	Insp Result	Insp Lvl	Fault Action	Fault Category	Fault desc	COF Expiry Date
13/11/2018	117159	WHG676	PHL16	Goods van/truck/utility	Pass	5, 3	No Action			26/01/2019
13/11/2018	117159	WHG676	S25E	Trailer/caravan	Pass	5, 3	No Action			26/01/2019
04/03/2019	126843	RBC411	7U983	Trailer/caravan	Pass	5, 3	No Action			26/03/2019
04/03/2019	126843	RBC411	PHL40	Goods van/truck/utility	Pass	5, 3	No Action			03/04/2019

DL Number: s9(2)(a)

Driver: s9(2)(a)

Insp Date	CVIR Sheet #	QID	Plate	Vehicle Types Meaning	Insp Result	Insp Lvl	Fault Action	Fault Category	Fault desc	COF Expiry Date
17/09/2018	872898	RBC411	PHL01	Goods van/truck/utility	Pass	5, 3	No Action			04/11/2018
17/09/2018	872898	RBC411	Z760L	Trailer/caravan	Fail	5, 3	Pink sticker	Lighting	No stop lamps fitted, no stop lamps working, are excessively damaged or fully obscured. Single vehicle or rear unit of combo	23/10/2018

DL Number: s9(2)(a)

Driver: s9(2)(a)

Insp Date	CVIR Sheet #	QID	Plate	Vehicle Types Meaning	Insp Result	Insp Lvl	Fault Action	Fault Category	Fault desc	COF Expiry Date
19/02/2019	126816	RBC411	PHL01	Goods van/truck/utility	Pass	5, 3	No Action			04/05/2019
19/02/2019	126816	RBC411	Z760L	Trailer/caravan	Pass	5, 3	No Action			23/04/2019

DL Number: s9(2)(a)

Driver: s9(2)(a)

Insp Date	CVIR Sheet #	QID	Plate	Vehicle Types Meaning	Insp Result	Insp Lvl	Fault Action	Fault Category	Fault desc	COF Expiry Date
18/12/2018	107332	PNIQ51	8K642	Trailer/caravan	Pass	5, 3	No Action			29/05/2019
18/12/2018	107332	PNIQ51	PHL13	Goods van/truck/utility	Pass	5, 3	No Action			15/06/2019
27/03/2019	136101	PNIQ51	8K642	Trailer/caravan	Pass	5, 3	No Action			29/05/2019
27/03/2019	136101	PNIQ51	PHL13	Goods van/truck/utility	Pass	5, 3	No Action			15/06/2019

DL Number: s9(2)(a)

Driver: s9(2)(a)

Insp Date	CVIR Sheet #	QID	Plate	Vehicle Types Meaning	Insp Result	Insp Lvl	Fault Action	Fault Category	Fault desc	COF Expiry Date
04/10/2017	832209	GGI670	GDU506	Goods van/truck/utility	Pass	5, 3	No Action			05/12/2017
04/10/2017	832209	GGI670	S532N	Trailer/caravan	Pass	5, 3	No Action			20/12/2017

DL Number: s9(2)(a)

Driver: s9(2)(a)

Insp Date	CVIR Sheet #	QID	Plate	Vehicle Types Meaning	Insp Result	Insp Lvl	Fault Action	Fault Category	Fault desc	COF Expiry Date
20/06/2018	857359	RBC411	GDU506	Goods van/truck/utility	Fail	3	Green 2 action	Lighting	Daytime running lamp works intermittently/operates with fog lights, not securely fitted or damaged	06/12/2018
10/08/2018	867925	RBC411	GDU506	Goods van/truck/utility	Fail	3	Green 2 action	Lighting	Daytime running lamp works intermittently/operates with fog lights, not securely fitted or damaged	06/12/2018
20/02/2019	126823	RBC411	PHL06	Goods van/truck/utility	Fail	5, 3	Green 2 action	Lighting	Side marker lamp not operational, not secure, damaged or obscured	26/05/2019
20/02/2019	126823	RBC411	Z505Y	Trailer/caravan	Pass	5, 3	No Action			21/05/2019

DL Number: s9(2)(a)

Driver: s9(2)(a)

Insp Date	CVIR Sheet #	QID	Plate	Vehicle Types Meaning	Insp Result	Insp Lvl	Fault Action	Fault Category	Fault desc	COF Expiry Date
03/04/2018	854929	RBC411	PHL26	Goods van/truck/utility	Pass	3	No Action			01/08/2018
13/11/2018	117057	BWD335	9Z511	Trailer/caravan	Pass	5, 3	No Action			13/01/2019
13/11/2018	117057	BWD335	PHL42	Goods van/truck/utility	Pass	5, 3	No Action			13/01/2019
27/03/2019	136324	PNIQ51	9Z511	Trailer/caravan	Fail	5, 3	Pink sticker	Brakes	Air tank mounts broken – tanks insecure	10/07/2019
27/03/2019	136324	PNIQ51	PHL42	Goods van/truck/utility	Pass	5, 3	No Action			10/07/2019

DL Number: s9(2)(a)

Driver: s9(2)(a)

Insp Date	CVIR Sheet #	QID	Plate	Vehicle Types Meaning	Insp Result	Insp Lvl	Fault Action	Fault Category	Fault desc	COF Expiry Date
05/12/2017	839683	RBC411	PHL04	Goods van/truck/utility	Pass	3	No Action			02/05/2018

DL Number: s9(2)(a)

Driver: s9(2)(a)

Insp Date	CVIR Sheet #	QID	Plate	Vehicle Types Meaning	Insp Result	Insp Lvl	Fault Action	Fault Category	Fault desc	COF Expiry Date
11/01/2018	841627	BWD335	PHL16	Goods van/truck/utility	Fail	5, 3	Green sticker	Mudguards	One mudguard missing/does not comply or a mudflap not fitted to a twin tyred axle	26/07/2018
11/01/2018	841627	BWD335	PHL16	Goods van/truck/utility	Fail	5, 3	Pink sticker	Wheels and Tyres	A tyre is damaged – operation affected and/or failure imminent	26/07/2018
11/01/2018	841627	BWD335	S25E	Trailer/caravan	Pass	5, 3	No Action			26/07/2018

DL Number: s9(2)(a)

Driver: s9(2)(a)

Insp Date	CVIR Sheet #	QID	Plate	Vehicle Types Meaning	Insp Result	Insp Lvl	Fault Action	Fault Category	Fault desc	COF Expiry Date
25/06/2018	861241	RBC411	PHL12	Goods van/truck/utility	Fail	3	Green 2 action	Lighting	One direction Indicator lamp not working	24/10/2018
25/06/2018	861241	RBC411	PHL12	Goods van/truck/utility	Fail	3	Green 2 action	Lighting	One or more front park lamps not operational (anytime)	24/10/2018

DL Number: s9(2)(a)

Driver: s9(2)(a)

Insp Date	CVIR Sheet #	QID	Plate	Vehicle Types Meaning	Insp Result	Insp Lvl	Fault Action	Fault Category	Fault desc	COF Expiry Date
03/10/2017	828698	GME708	J880M	Trailer/caravan	Pass	5, 3	No Action			22/12/2017
03/10/2017	828698	GME708	PHL29	Goods van/truck/utility	Pass	5, 3	No Action			21/12/2017
14/11/2017	814676	BLDA87	K438A	Trailer/caravan	Fail	5	Pink sticker	Lighting	No stop lamps fitted, no stop lamps working, are excessively damaged or fully obscured. Single vehicle or rear unit of combo	17/05/2018
14/11/2017	814676	BLDA87	PHL04	Goods van/truck/utility	Pass	5	No Action			02/05/2018
13/04/2018	850703	BLDA87	PHL02	Goods van/truck/utility	Fail	5	Green 2 action	Wheels and Tyres	1 wheel nut loose/missing, 1 stud damaged/missing	07/10/2018
13/04/2018	850703	BLDA87	R177T	Trailer/caravan	Pass	5	No Action			07/10/2018
26/04/2018	857314	RBC411	PHL02	Goods van/truck/utility	Pass	3	No Action			07/10/2018
26/04/2018	857314	RBC411	R177T	Trailer/caravan	Fail	3	Green 2 action	Lighting	One required rear reflector fitted, not securely fitted, colour other than red, anytime	07/10/2018
25/06/2018	861240	RBC411	PHL02	Goods van/truck/utility	Fail	3	Green sticker	Lighting	Direction indicator lamp is damaged, fully obscured or output affected/failure imminent or is not securely fitted (detachment is imminent)	07/10/2018
10/08/2018	867923	RBC411	PHL02	Goods van/truck/utility	Pass	2	No Action			07/10/2018
10/08/2018	867923	RBC411	R177T	Trailer/caravan	Fail	2	Pink sticker	Load Anchorage	Sliding bolster – no locking mechanism	07/10/2018
10/08/2018	867923	RBC411	R177T	Trailer/caravan	Fail	2	Green 2 action	Lighting	One direction Indicator lamp not working	07/10/2018
15/11/2018	121783	WDJ177	PHL02	Goods van/truck/utility	Pass	5, 3	No Action			08/04/2019
15/11/2018	121783	WDJ177	R177T	Trailer/caravan	Fail	5, 3	Pink sticker	Wheels and Tyres	Side wall unzipping	08/04/2019
21/02/2019	126829	RBC411	PHL02	Goods van/truck/utility	Pass	5, 3	No Action			08/04/2019
21/02/2019	126829	RBC411	R177T	Trailer/caravan	Fail	5, 3	Pink sticker	Lighting	No stop lamps fitted, no stop lamps working, are excessively damaged or fully obscured. Single vehicle or rear unit of combo	08/04/2019
21/02/2019	126829	RBC411	R177T	Trailer/caravan	Fail	5, 3	Pink sticker	Lighting	Whole indicator system does not operate	08/04/2019
21/02/2019	126829	RBC411	R177T	Trailer/caravan	Fail	5, 3	Green 2 action	Lighting	Side marker lamp not operational, not secure, damaged or obscured	08/04/2019
21/02/2019	126829	RBC411	R177T	Trailer/caravan	Fail	5, 3	Green 2 action	Lighting	A rear tail lamp is not operating, damaged or fully obscured	08/04/2019

DL Number: s9(2)(a)

Driver: s9(2)(a)

Insp Date	CVIR Sheet #	QID	Plate	Vehicle Types Meaning	Insp Result	Insp Lvl	Fault Action	Fault Category	Fault desc	COF Expiry Date
17/07/2018	861276	RBC411	PHL07	Goods van/truck/utility	Fail	3	Green 2 action	Lighting	Stop lamp emits colour other than red, or is obscured	16/12/2018

DL Number: s9(2)(a)

Driver: s9(2)(a)

Insp Date	CVIR Sheet #	QID	Plate	Vehicle Types Meaning	Insp Result	Insp Lvl	Fault Action	Fault Category	Fault desc	COF Expiry Date
29/05/2019	136145	PNIQ51	GDU506	Goods van/truck/utility	Fail	5, 3	Green 2 action	Vision	Windscreen wiper not fitted, not operational, loose or damaged	06/06/2019
05/06/2019	150784	BWD335	PHL01	Goods van/truck/utility	Pass	5, 3	No Action			04/11/2019
05/06/2019	150784	BWD335	Z760L	Trailer/caravan	Pass	5, 3	No Action			23/10/2019

Released under the Official Information Act 1982

DL Number: s9(2)(a)

Driver: s9(2)(a)

Insp Date	CVIR Sheet #	QID	Plate	Vehicle Types Meaning	Insp Result	Insp Lvl	Fault Action	Fault Category	Fault desc	COF Expiry Date
03/10/2017	833895	PJAT18	5W717	Trailer/caravan	Pass	5, 3	No Action			31/10/2017
03/10/2017	833895	PJAT18	PHL27	Goods van/truck/utility	Pass	5, 3	No Action			19/10/2017
02/11/2017	837235	RBC411	5W717	Trailer/caravan	Fail	3	Pink sticker	Lighting	No stop lamps fitted, no stop lamps working, are excessively damaged or fully obscured. Single vehicle or rear unit of combo	30/04/2018
02/11/2017	837235	RBC411	PHL27	Goods van/truck/utility	Fail	3	Green sticker	Lighting	One or more than two daytime running lamps fitted	19/04/2018
02/11/2017	837235	RBC411	PHL27	Goods van/truck/utility	Fail	3	Green 2 action	Lighting	A headlamp is damaged failure is imminent or light output on either side is not approx equal	19/04/2018
20/06/2018	857358	RBC411	PHL27	Goods van/truck/utility	Fail	3	Pink sticker	Lighting	No stop lamps fitted, no stop lamps working, are excessively damaged or fully obscured. Single vehicle or rear unit of combo	19/10/2018
15/11/2018	117175	WHG676	5W717	Trailer/caravan	Fail	5, 3	Green sticker	Brakes	Stroke of brake chamber exceeds manufacturer's limit - service brake performance doesn't meet legal requirements	30/04/2019
15/11/2018	117175	WHG676	PHL27	Goods van/truck/utility	Pass	5, 3	No Action			19/04/2019
23/05/2019	150773	BWD335	PHL27	Goods van/truck/utility	Fail	5, 3	Green sticker	Mudguards	One mudguard missing/does not comply or a mudflap not fitted to a twin tyred axle	21/12/2019
23/05/2019	150773	BWD335	PHL27	Goods van/truck/utility	Fail	5, 3	Green sticker	Wheels and Tyres	Tread insufficient, any other tyres – not operated in rain	21/12/2019

Released under the Official Information Act 1982

DL Number: s9(2)(a)

Driver: s9(2)(a)

Insp Date	CVIR Sheet #	QID	Plate	Vehicle Types Meaning	Insp Result	Insp Lvl	Fault Action	Fault Category	Fault desc	COF Expiry Date
14/11/2018	114553	RBC411	PHL2O	Goods van/truck/utility	Fail	5, 3	Green sticker	Brakes	Spring brake/electric brake control for parking brakes not protected from inadvertent release	07/03/2019
14/11/2018	114553	RBC411	PHL2O	Goods van/truck/utility	Fail	5, 3	Green sticker	Suspension	Shock absorber missing, damaged or leaking excessively (wet or dripping)	07/03/2019
14/11/2018	114553	RBC411	T674A	Trailer/caravan	Fail	5, 3	Pink sticker	Brakes	Air leak low air pressure <30 seconds	07/03/2019
14/11/2018	114553	RBC411	T674A	Trailer/caravan	Fail	5, 3	Green 2 action	Load Anchorage	Bolster not securely fitted or attachment is damaged – no immediate risk of failure	07/03/2019
12/12/2018	107318	PNIQ51	PHL2O	Goods van/truck/utility	Pass	5, 3	No Action			07/03/2019
12/12/2018	107318	PNIQ51	T674A	Trailer/caravan	Fail	5, 3	Pink sticker	Suspension	Air bag damaged/fully deflated – laden	07/03/2019
26/03/2019	141801	RSJ147	PHL2O	Goods van/truck/utility	Pass	5, 3	No Action			07/09/2019
26/03/2019	141801	RSJ147	T674A	Trailer/caravan	Fail	5, 3	Pink sticker	Wheels and Tyres	A tyre is damaged – operation affected and/or failure imminent	07/09/2019

Released under the Official Information Act 1982



DL Number: s9(2)(a)

Driver: s9(2)(a)

Insp Date	CVIR Sheet #	QID	Plate	Vehicle Types Meaning	Insp Result	Insp Lvl	Fault Action	Fault Category	Fault desc	COF Expiry Date
04/10/2017	832205	GGI670	PHL20	Goods van/truck/utility	Pass	5, 3	No Action			06/03/2018
04/10/2017	832205	GGI670	T674A	Trailer/caravan	Pass	5, 3	No Action			07/03/2018
14/11/2018	114556	RBC411	6F838	Trailer/caravan	Fail	5, 3	Green 2 action	Brakes	Suzie coil hose does not comply, support spring missing/ineffective	18/01/2019
14/11/2018	114556	RBC411	6F838	Trailer/caravan	Fail	5, 3	Pink sticker	Brakes	ABS/EBS system is not operating - Combination vehicle	18/01/2019
14/11/2018	114556	RBC411	6F838	Trailer/caravan	Fail	5, 3	Green 2 action	Lighting	One required rear reflector fitted, not securely fitted, colour other than red, anytime	18/01/2019
14/11/2018	114556	RBC411	6F838	Trailer/caravan	Fail	5, 3	Green 2 action	Ball-race Turntables	Ball-race turntable fasteners loose (other)	18/01/2019
14/11/2018	114556	RBC411	PHL28	Goods van/truck/utility	Fail	5, 3	Green 2 action	Lighting	Daytime running lamp works intermittently/operates with fog lights, not securely fitted or damaged	18/01/2019
14/11/2018	114556	RBC411	PHL28	Goods van/truck/utility	Fail	5, 3	Green 2 action	Lighting	One required headlamp is not fitted, not securely attached or is not operational	18/01/2019
22/05/2019	150780	BWD335	6F838	Trailer/caravan	Pass	5, 3	No Action			15/07/2019
22/05/2019	150780	BWD335	PHL28	Goods van/truck/utility	Pass	5, 3	No Action			15/07/2019

Released under the Official Information Act 1982

DL Number: s9(2)(a)

Driver: s9(2)(a)

Insp Date	CVIR Sheet #	QID	Plate	Vehicle Types Meaning	Insp Result	Insp Lvl	Fault Action	Fault Category	Fault desc	COF Expiry Date
05/10/2017	836073	PJAT18	PHL22	Goods van/truck/utility	Fail	5, 3	Pink sticker	Brakes	Park brake actuator missing/not operational/does not lock into position, remains applied when released, is not securely fastened & may detach. Risk of inadvertent release	26/01/2018
05/10/2017	836073	PJAT18	R462K	Trailer/caravan	Pass	5, 3	No Action			26/01/2018
25/06/2018	861239	RBC411	PHL20	Goods van/truck/utility	Fail	3	Green 2 action	Lighting	A fog lamp is insecure, damaged or out of alignment	07/09/2018
25/06/2018	861239	RBC411	PHL20	Goods van/truck/utility	Fail	3	Green 2 action	Lighting	One direction Indicator lamp not working	07/09/2018
25/06/2018	861239	RBC411	PHL20	Goods van/truck/utility	Fail	3	Green 2 action	Lighting	One required rear reflector fitted, not securely fitted, colour other than red, anytime	07/09/2018
17/08/2018	872868	RBC411	9Z516	Trailer/caravan	Pass	3	No Action			24/01/2019
17/08/2018	872868	RBC411	PHL43	Goods van/truck/utility	Pass	3	No Action			24/01/2019
15/11/2018	117941	JB227	9Z516	Trailer/caravan	Pass	5, 3	No Action			24/01/2019
15/11/2018	117941	JB227	PHL43	Goods van/truck/utility	Pass	5, 3	No Action			24/01/2019
10/05/2019	136118	PNIQ51	9Z516	Trailer/caravan	Pass	5, 3	No Action			24/07/2019
10/05/2019	136118	PNIQ51	PHL43	Goods van/truck/utility	Pass	5, 3	No Action			24/07/2019

Total Vehicles Inspected:	212	Fault Action	Total	Vehicle Action	Total
Total Faults:	105	Pink sticker	31	Compliance	11
Total Fails:	78	Green sticker	23	No Action	133
Total Passes:	134	Green 2 action	51	Pink	2
Total Fault Actions:	105	No Action	134	Roadside Remedy	18
Avg No Faults per Vehicle:	0.50		239	Verbal Direction	48
Avg No. Faults per Failed Vehicle:	1.35				212

### Summary of Passes and Fails

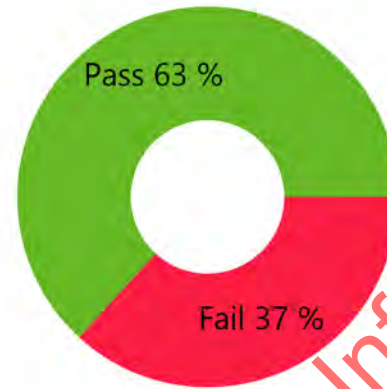

Total Fails:	78
% of Vehicles Failed:	36.8%
Total Passes:	134
% of Vehicles Passed:	63.2%
No. Faults Found:	105

### Frequency of Faults

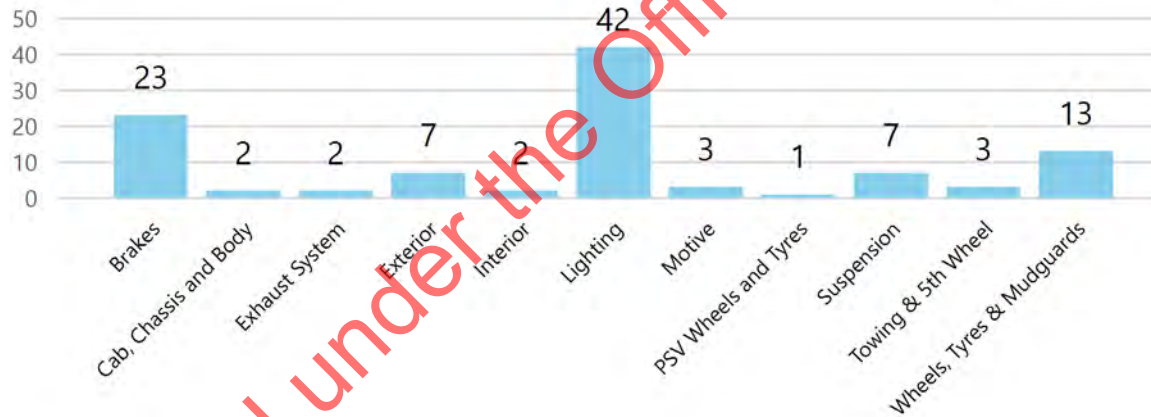

Fault Category	# Faults	% of Vehicles
Brakes	23	22%
Cab, Chassis and Body	2	2%
Exhaust System	2	2%
Exterior	7	7%
Interior	2	2%
Lighting	42	40%
Motive	3	3%
PSV Wheels and Tyres	1	1%
Suspension	7	7%
Towing & 5th Wheel	3	3%
Wheels, Tyres & Mudguards	13	12%
<b>Total</b>	<b>105</b>	<b>100%</b>

### Fails By Month

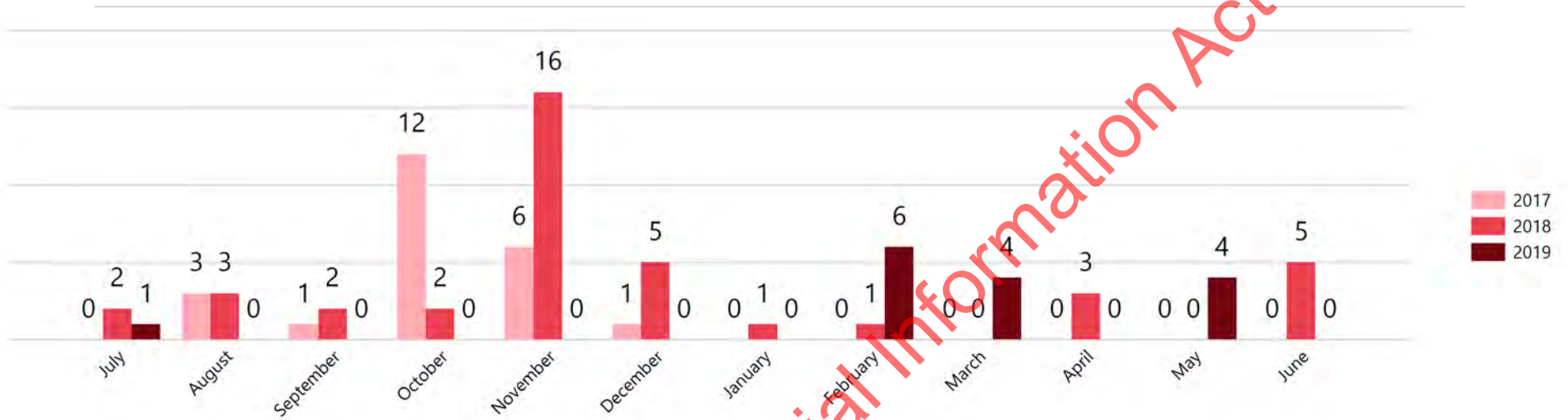

### Passes By Month

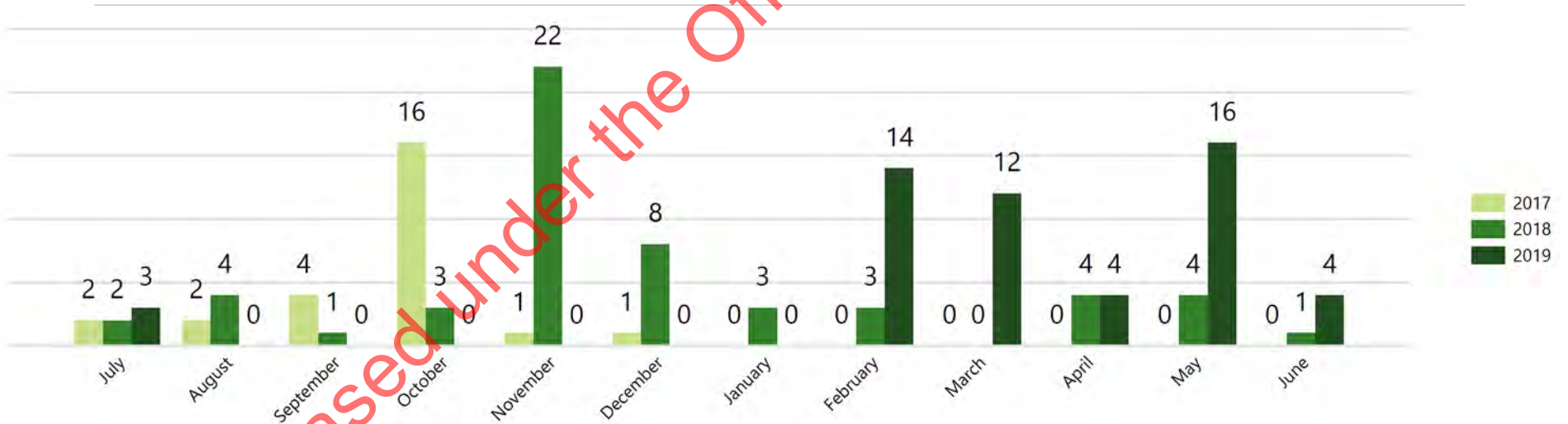

### Pass / Fail Per Inspection Level by Vehicle

Level	Fail	Pass	Total
2	1	1	2
3	19	19	38
5	3	10	13
5, 3	53	104	157
6, 3	2	0	2
<b>Total</b>	<b>78</b>	<b>134</b>	<b>212</b>

### Number of Faults Per Inspection Level

Highest Level	No of Faults
2	2
3	24
5	3
5, 3	73
6, 3	3
<b>Total</b>	<b>105</b>

### Fault Action by Inspection Level

Level	Fault Action	Fail	Pass
2	Green 2 action	1	0
	No Action	0	1
	Pink sticker	1	0
3	Green 2 action	15	0
	Green sticker	4	0
	No Action	0	19
	Pink sticker	5	0
	Green 2 action	2	0
5	No Action	0	10
	Pink sticker	1	0
	Green 2 action	30	0
5, 3	Green sticker	19	0
	No Action	0	104
	Pink sticker	24	0
6, 3	Green 2 action	3	0
	<b>Total</b>	<b>105</b>	<b>134</b>

Released under the Official Information Act 1982

### Inspection Notes

Date/Time	Plate	Vehicle Details	Inspection Notes
22/07/17 11:18 AM	7P447 PHL37	2017 KENWORTH T 2017 KRAFT 400	Log Book Page: Rtfn220322-6
1/08/17 1:49 PM	H469A PHL07	2006 EVANS 4AC 2009 KENWORTH T	Log Book Page: RTFNZ 002979-27
11/08/17 8:05 AM	PHL13	2001 KENWORTH K104	Log Book Page: RTF 459426-50.
22/08/17 4:24 PM	K898F PHL05	2007 KENWORTH T 2007 KRAFT 400	Log Book Page: PHL 0061-7
5/09/17 12:25 PM	PHL35 T672A	2012 KRAFT 400 2014 KENWORTH T	Log Book Page: RTF 459409-50
8/09/17 5:59 AM	L402L PHL11	2008 KENWORTH T 2008 KRAFT 404	Log Book Page: PHL 0084-7
11/09/17 6:36 AM	PHL01	2014 KENWORTH T	Log Book Page: PHL 0099-7
3/10/17 10:12 AM	PHL23 Q884L	2010 KENWORTH T408 2010 KRAFT 404	Log Book Page: Phl026
3/10/17 10:22 AM	J880M PHL29	2001 EVANS 4AS 2010 KENWORTH K108	Log Book Page: PHL 0052-5
3/10/17 12:15 PM	M829A PHL12	2008 KENWORTH T 2008 KRAFT 404	Log Book Page: Phl 0069-28 Driver notes: Driver advised of repair to be completed and given pink sticker.
3/10/17 2:18 PM	7B837 PHL25	2017 KENWORTH T 2017 KRAFT 400	Log Book Page: PHL 0058-38
3/10/17 2:52 PM	5W717 PHL27	2016 KENWORTH T 2016 KRAFT 400	Log Book Page: PHL 0072-20
4/10/17 7:24 AM	J880M PHL29	2001 EVANS 4AS 2010 KENWORTH K108	Log Book Page: Phl091 Driver notes: Compliance ticket for tyre.
4/10/17 8:32 AM	PHL20 T674A	2012 KENWORTH K108 2012 KRAFT 404	Log Book Page: Phl090
4/10/17 11:06 AM	GDU506 S532N	2011 KENWORTH T 2011 KRAFT 404	Log Book Page: Phl074
4/10/17 1:14 PM	7K728 PHL38	2017 KENWORTH T 2017 KRAFT 400	Log Book Page: PHL0089-34
4/10/17 3:36 PM	K239N PHL10	2007 KENWORTH T 2007 KRAFT 404	Log Book Page: PHL 0078-28

5/10/17 8:30 AM	PHL35 T672A	2012 KRAFT 400 2014 KENWORTH T	Log Book Page: Phl 0022-2
5/10/17 2:48 PM	PHL22 R462K	2011 KENWORTH K 2011 KRAFT 404	Log Book Page: Nza 6567-04 Driver notes: Ion with compliance for company.
11/10/17 7:38 AM	H469A PHL07	2006 EVANS 4AC 2009 KENWORTH T	Log Book Page: PHL 0064-49
19/10/17 10:53 AM	K438A PHL04	2007 KENWORTH K104 2007 KRAFT 404	Log Book Page: PHL 0032-27
1/11/17 6:11 AM	PHL36	2017 KENWORTH T	Log Book Page: PHL 0083-47
2/11/17 11:00 AM	5W717 PHL27	2016 KENWORTH T 2016 KRAFT 400	Log Book Page: PHL 0072-42
14/11/17 10:02 AM	K438A PHL04	2007 KENWORTH K104 2007 KRAFT 404	Log Book Page: 0052-26
30/11/17 1:58 PM	K239N PHL10	2007 KENWORTH T 2007 KRAFT 404	Log Book Page: PHL 0053-14
5/12/17 2:57 AM	PHL10	2007 KENWORTH T	Log Book Page: PHL 0053-18
5/12/17 3:32 AM	PHL04	2007 KENWORTH K104	Log Book Page: PHL 0019-39
11/01/18 2:18 PM	PHL16 S25E	2011 KENWORTH K108 2011 KRAFT 404	Log Book Page: Phl004549
18/01/18 12:10 PM	6Y910 PHL36	2017 KENWORTH T 2017 KRAFT 400	Log Book Page: PHL 0034-39
8/02/18 10:31 AM	PHL31 W970G	2013 KENWORTH T 2013 KRAFT 404	Log Book Page: PHL 008-6 Driver notes: Windscreen damaged LHS.
27/02/18 6:53 AM	PHL06 Z505Y	2014 KENWORTH T 2014 KRAFT 404	Log Book Page: Phl01158
3/04/18 1:39 PM	PHL26	2016 KENWORTH T	Log Book Page: PHL 0118-21
13/04/18 7:03 AM	PHL02 R177T	2011 KENWORTH K108 2011 KRAFT 404	
16/04/18 7:04 AM	P352C PHL15	2009 KENWORTH T 2009 KRAFT 404	Log Book Page: PHL 0112-42 Driver notes: I-Bright RUC machine to be able to be viewed by enforcement officer out side of truck (either door).
26/04/18 7:42 AM	PHL02 R177T	2011 KENWORTH K108 2011 KRAFT 404	Log Book Page: PHL 0191-15

Released under the Official Information Act 1982

3/05/18 7:38 AM	PHL18	2010 KENWORTH T	ADDITIONAL NOTES: 508482,
11/05/18 7:13 AM	PHL29 U789M	2010 KENWORTH K108 2013 KRAFT 404	Log Book Page: PHL 0124-46
17/05/18 11:50 AM	PHL23	2010 KENWORTH T408	Log Book Page: PHL 0171-6 Driver notes: LHS mirror marker lamps to operate.
20/06/18 6:05 AM	PHL32	2013 KENWORTH T	Log Book Page: PHL 0199-41
20/06/18 8:29 AM	PHL27	2016 KENWORTH T	Log Book Page: PHL 000266-34
20/06/18 9:48 AM	GDU506	2011 KENWORTH T	Log Book Page: PHL0215-17
25/06/18 2:35 PM	PHL20	2012 KENWORTH K108	Log Book Page: PHL 0166-21
25/06/18 3:08 PM	PHL02	2011 KENWORTH K108	Log Book Page: PHL0191-49
25/06/18 3:32 PM	PHL12	2008 KENWORTH T	Log Book Page: PHL 0160-2
7/07/18 6:40 AM	7P447 PHL37	2017 KENWORTH T 2017 KRAFT 400	Log Book Page: PHL 000270-42
13/07/18 10:47 AM	PHL37	2017 KENWORTH T	Log Book Page: PHL 000270-47
17/07/18 12:02 PM	PHL07	2009 KENWORTH T	Log Book Page: PHL 0136-4
10/08/18 7:00 AM	PHL02 R177T	2011 KENWORTH K108 2011 KRAFT 404	Log Book Page: PHL 0153-23
10/08/18 12:04 PM	GDU506	2011 KENWORTH T	Log Book Page: PHL 000210-01
16/08/18 10:08 AM	M829A PHL12	2008 KENWORTH T 2008 KRAFT 404	Log Book Page: PHL 0150-28
17/08/18 7:17 AM	92516 PHL43	2018 KENWORTH T 2018 KRAFT 505	Log Book Page: PHL 000219-09
17/09/18 2:10 PM	PHL01 Z760L	2014 KENWORTH T 2014 KRAFT 404	Log Book Page: PHL 000225-15
27/09/18 11:57 AM	PHL05	2007 KENWORTH T	Log Book Page: PHL 000228-24
3/10/18 7:28 AM	PHL30 R443P	2011 KENWORTH K 2011 KRAFT 404	Log Book Page: PHL 000207-23 Driver notes: Washers to operate



26/10/18 1:22 PM	K898F PHL05	2007 KENWORTH T 2007 KRAFT 400	Log Book Page: Phl00022843
30/10/18 2:41 AM	PHL12	2008 KENWORTH T	Log Book Page: Phl000284 18 Driver notes: Trailer lights not operating
8/11/18 1:52 PM	PHL06 Z505Y	2014 KENWORTH T 2014 KRAFT 404	Log Book Page: PHL 000277-31
12/11/18 12:03 PM	PHL32 W198L	2013 KENWORTH T 2013 KRAFT 404	Log Book Page: PHL 000223-38
13/11/18 5:44 AM	9Z511 PHL42	2018 KENWORTH T 2018 KRAFT 505	Log Book Page: Phl00028233
13/11/18 7:10 AM	PHL16 S25E	2011 KENWORTH K108 2011 KRAFT 404	Log Book Page: Phl224-31 0430 gisborne
13/11/18 8:45 AM	PHL35 T672A	2012 KRAFT 400 2014 KENWORTH T	Log Book Page: PHL 000231-14
13/11/18 8:48 AM	6Y910 PHL36	2017 KENWORTH T 2017 KRAFT 400	Log Book Page: Phl00028737 Driver notes: Made a visit to s9(2)(b)(ii) and spoke to s9(2)(b)(ii) the workshop manager. I Explained the requirements for a full trailer operating with suzi coils as per Heavy brake rule.
13/11/18 1:26 PM	K898F PHL05	2007 KENWORTH T 2007 KRAFT 400	Log Book Page: PHL 000238-0
14/11/18 7:40 AM	PHL23 Q884L	2010 KENWORTH T408 2010 KRAFT 404	Log Book Page: PHL 000243-09 Driver notes: Verbal Warning given bolster pins not in 2nd bolster
14/11/18 8:18 AM	PHL20 T674A	2012 KENWORTH K108 2012 KRAFT 404	Log Book Page: PHL 000237-13
14/11/18 9:41 AM	6F838 PHL28	2017 KENWORTH T 2017 KRAFT 400	Log Book Page: PHL276-33
14/11/18 11:06 AM	PHL18 R179F	2010 KENWORTH T 2011 KRAFT 404	Log Book Page: PHL 000295-14
14/11/18 11:46 AM	N102T PHL14	2009 KENWORTH K108 2009 KRAFT 404	Log Book Page: PHL 000234-22
15/11/18 7:13 AM	4Z305 PHL26	2016 KENWORTH T 2016 KRAFT 404	Log Book Page: Phl236-05 0400 gisborne
15/11/18 8:43 AM	5W717 PHL27	2016 KENWORTH T 2016 KRAFT 400	Log Book Page: Phl280-38 0000 awapuni road
15/11/18 10:58 AM	PHL34 Y951K	2014 KENWORTH T 2014 KRAFT 404	Log Book Page: PHL 0229-43
15/11/18 1:26 PM	9Z506 PHL41	2018 KENWORTH T 2018 KRAFT 507	Log Book Page: PHL 000297-22 Gisborne 0400

15/11/18 1:48 PM	PHL02 R177T	2011 KENWORTH K108 2011 KRAFT 404	Log Book Page: PHL 000279-39 Gisborne 0500 Driver notes: Chip in windscreen in upper part of drivers CVA. Windscreen to be replaced within 14 days. 3rd axle LHS outer tyre un zipping. Photos taken. Bar between 1st and 2nd axle under transmission cracked RHS. Driver informed of faults.
15/11/18 1:52 PM	9Z516 PHL43	2018 KENWORTH T 2018 KRAFT 505	Log Book Page: PHL 000232-24
26/11/18 5:59 AM	4Z305 PHL26	2016 KENWORTH T 2016 KRAFT 404	Log Book Page: PHL 000236-13
3/12/18 6:09 AM	PHL33	2013 KENWORTH T	Log Book Page: PHL 0294-33
3/12/18 10:46 AM	PHL09 Z745L	2014 KENWORTH T 2014 KRAFT 404	Log Book Page: PHL 0281-43
12/12/18 6:46 AM	4Z305 PHL26	2016 KENWORTH T 2016 KRAFT 404	Log Book Page: PHL 0236-26
12/12/18 7:31 AM	PHL20 T674A	2012 KENWORTH K108 2012 KRAFT 404	Log Book Page: 000237-33
13/12/18 10:20 AM	7B837 PHL25	2017 KENWORTH T 2017 KRAFT 400	Log Book Page: PHL 000260-02
18/12/18 3:07 PM	8K642 PHL13	2017 KENWORTH T 2017 KRAFT 404	Log Book Page: Phl 000247-26
19/12/18 7:48 AM	PHL30 R443P	2011 KENWORTH K 2011 KRAFT 404	Log Book Page: PHL 000253-10
5/02/19 3:26 PM	K898F PHL05	2007 KENWORTH T 2007 KRAFT 400	Log Book Page: PHL 000323-02
8/02/19 10:32 AM	P352C PHL15	2009 KENWORTH T 2009 KRAFT 404	Log Book Page: PHL 000318-09
14/02/19 3:28 PM	7P447 PHL37	2017 KENWORTH T 2017 KRAFT 400	Log Book Page: PHL 000264-37
19/02/19 6:27 AM	7K728 PHL38	2017 KENWORTH T 2017 KRAFT 400	Log Book Page: PHL 000254-38
19/02/19 7:27 AM	PHL01 Z760L	2014 KENWORTH T 2014 KRAFT 404	Log Book Page: PHL 000303-30
20/02/19 6:51 AM	PHL06 Z505Y	2014 KENWORTH T 2014 KRAFT 404	Log Book Page: PHL 000240-49
21/02/19 5:54 AM	PHL35 T672A	2012 KRAFT 400 2014 KENWORTH T	Log Book Page: PHL 000315-21

21/02/19 6:27 AM	PHL02 R177T	2011 KENWORTH K108 2011 KRAFT 404	Log Book Page: PHL 00026-46
27/02/19 5:56 AM	4Z305 PHL26	2016 KENWORTH T 2016 KRAFT 404	Log Book Page: PHL 000317-21
28/02/19 8:14 AM	9Z506 PHL41	2018 KENWORTH T 2018 KRAFT 507	Log Book Page: PHL 0301-40
4/03/19 5:51 AM	7U983 PHL40	2017 KENWORTH T 2017 KRAFT 404	Log Book Page: Yes Log Book Page: PHL 000256-33
25/03/19 9:18 AM	PHL16 S25E	2011 KENWORTH K108 2011 KRAFT 404	Log Book Page: Yes Log Book Page: PHL 0313-38
26/03/19 7:15 AM	9Z506 PHL41	2018 KENWORTH T 2018 KRAFT 507	Log Book Page: Yes Log Book Page: PHL41 000342-09
26/03/19 8:05 AM	PHL20 T674A	2012 KENWORTH K108 2012 KRAFT 404	Log Book Page: Yes Log Book Page: PHL 0311-36 Driver notes: Driver spoken to about front 'H' on front of truck is damaged/torn to be replaced. Tyre on trailer right side 3rd axle outside tyre damaged to be replaced (Advised to re-configure chain restraints as chains getting damaged/worn). Infringement notice to follow with compliance.
27/03/19 5:24 AM	9Z511 PHL42	2018 KENWORTH T 2018 KRAFT 505	Log Book Page: Yes Log Book Page: Phl389-17 0200 gisborne
27/03/19 5:57 AM	7B837 PHL25	2017 KENWORTH T 2017 KRAFT 400	Log Book Page: Yes Log Book Page: Phl260-47 0215 matawhero
27/03/19 11:35 AM	8K642 PHL13	2017 KENWORTH T 2017 KRAFT 404	Log Book Page: Yes Log Book Page: PHL 000330-27
27/03/19 3:56 PM	PHL30 R443P	2011 KENWORTH K 2011 KRAFT 404	Log Book Page: Yes Log Book Page: PHL 000376-01 Driver notes: Driver spoken to about Trailer rear axle brakes require adjustment, shows excessive travel in slack adjuster. Suggest all trailer brakes to be adjusted.
1/04/19 3:44 PM	6Y910 PHL36	2017 KENWORTH T 2017 KRAFT 400	Log Book Page: Yes Log Book Page: PHL 0329-23

5/04/19 2:16 PM		PHL41	2018 KENWORTH T	Log Book Page: Yes Log Book Page: PHL 0342-18
11/04/19 3:07 AM		PHL37	2017 KENWORTH T	Log Book Page: Yes Log Book Page: PHL 000360-26
10/05/19 7:55 AM		9Z516 PHL43	2018 KENWORTH T 2018 KRAFT 505	Log Book Page: Yes Log Book Page: PHL 000361-16
16/05/19 11:41 AM		13Q38 PHL10	2018 KENWORTH T 2018 KRAFT 505	Log Book Page: Yes Log Book Page: PHL 000365-02
16/05/19 2:59 PM		7P447 PHL37	2017 KENWORTH T 2017 KRAFT 400	Log Book Page: Yes Log Book Page: PHL 000360-45
17/05/19 8:39 AM		8A839 PHL39	2017 KENWORTH T 2017 KRAFT 404	Log Book Page: Yes Log Book Page: Phl00029650
21/05/19 6:44 AM		PHL02 R177T	2011 KENWORTH K108 2011 KRAFT 404	Log Book Page: Yes Log Book Page: PHL 0372-46
22/05/19 2:30 PM		6F838 PHL28	2017 KENWORTH T 2017 KRAFT 400	Log Book Page: No Log Book Not Produced Reason: Not required
23/05/19 8:29 AM		PHL27	2016 KENWORTH T	Log Book Page: Yes Log Book Page: Phl00035203
27/05/19 7:57 AM		K898F PHL05	2007 KENWORTH T 2007 KRAFT 400	Log Book Page: Yes Log Book Page: PHL 000338-16
27/05/19 11:37 AM		9C103 PHL17	2018 KENWORTH T 2018 KRAFT 505	Log Book Page: Yes Log Book Page: PHL 0328-43
29/05/19 6:17 AM		PHL19 S597H	2011 KENWORTH K 2011 KRAFT 404	Log Book Page: Yes Log Book Page: PHL 000354-06
29/05/19 8:04 AM		GDU506	2011 KENWORTH T	Log Book Page: Yes Log Book Page: PHL 000392-19

5/06/19 8:11 AM	PHL01 Z760L	2014 KENWORTH T 2014 KRAFT 404	Log Book Page: Yes Log Book Page: Phl000392 23
21/06/19 9:54 AM	PHL35	2014 KENWORTH T	Log Book Page: Yes Log Book Page: PHL 000356-18
27/06/19 10:59 AM	PHL25	2017 KENWORTH T	Log Book Page: Yes Log Book Page: PHL 0404-7
2/07/19 11:27 AM	9Z506 PHL41	2018 KENWORTH T 2018 KRAFT 507	Log Book Page: Yes Log Book Page: PHL41 000351-36
4/07/19 9:57 AM	J816F PHL08	2007 KRAFT 400 2016 KENWORTH T	Log Book Page: Yes Log Book Page: PHL 000362-49

Released under the Official Information Act 1982

Operation:	<b>Roadside Inspection Checks</b>			
	From 28/02/2017 To 28/02/2019			
Operator:	§18(c)(i)			
Operator Name:	<b>PACIFIC HAULAGE LIMITED</b>			
Roadside Inspections:	<b>105</b>	Vehicles Inspected:	<b>188</b>	Vehicles with Faults: <b>82</b>

Insp Date	CVIR Sheet #	QID	Plate	Vehicle Types Meaning	Insp Result	Insp Lvl	Fault Action	Fault Category	Fault desc	COF Expiry Date
07/03/2017	805596	RBC411	M829A	Trailer/caravan	Fail	5, 3	Green 2 action	Lighting	One indicator light is not working on the rear of combination	24/04/2017
07/03/2017	805596	RBC411	PHL12	Goods van/truck/utility	Pass	5, 3	No Action			24/04/2017
14/03/2017	805609	RBC411	5W717	Trailer/caravan	Pass	3	No Action			22/05/2017
14/03/2017	805609	RBC411	PHL27	Goods van/truck/utility	Pass	3	No Action			19/04/2017
15/03/2017	801635	BWD335	PHL06	Goods van/truck/utility	Pass	5, 3	No Action			26/05/2017
15/03/2017	801635	BWD335	Z505Y	Trailer/caravan	Fail	5, 3	Pink sticker	Suspension	Suspension component not fitted/not securely fitted	21/05/2017
03/04/2017	810486	RBC411	PHL15	Goods van/truck/utility	Fail	3	Green 2 action	Lighting	One required headlamp is not fitted, not securely attached or is not operational	01/09/2017
03/04/2017	810486	RBC411	PHL15	Goods van/truck/utility	Fail	3	Green 2 action	Lighting	Direction indicator lamp is damaged, partially obscured output not affected or is loose.	01/09/2017
03/04/2017	810486	RBC411	PHL15	Goods van/truck/utility	Fail	3	Green 2 action	Lighting	A rear tail lamp is not operating, damaged or fully obscured	01/09/2017
11/04/2017	801923	BLDA87	PHL01	Goods van/truck/utility	Fail	5	Green 2 action	Fluid Leaks	Fluid leaks other	04/05/2017
11/04/2017	801923	BLDA87	Z760L	Trailer/caravan	Pass	5	No Action			23/04/2017
16/05/2017	815293	BWD335	PHL34	Goods van/truck/utility	Pass	5, 3	No Action			27/08/2017
16/05/2017	815293	BWD335	Y951K	Trailer/caravan	Pass	5, 3	No Action			28/08/2017
17/05/2017	815297	BWD335	PHL35	Goods van/truck/utility	Fail	5, 3	Green 2 action	Brakes	Air leaks any other system	17/11/2017
17/05/2017	815297	BWD335	T672A	Trailer/caravan	Pass	5, 3	No Action			08/11/2017
31/05/2017	815336	BWD335	7B837	Trailer/caravan	Pass	5, 3	No Action			28/10/2017
31/05/2017	815336	BWD335	PHL25	Goods van/truck/utility	Fail	5, 3	Green 2 action	Brakes	Air leaks any other system	02/11/2017
15/06/2017	816149	RBC411	PHL35	Goods van/truck/utility	Fail	5, 3	Green 2 action	Lighting	One stop lamp is fitted, not working, excessively damaged or fully obscured. Single vehicle or rear unit of combo	17/11/2017
15/06/2017	816149	RBC411	PHL35	Goods van/truck/utility	Fail	5, 3	Green 2 action	Lighting	One required headlamp is not fitted, not securely attached or is not operational	17/11/2017

Insp Date	CVIR Sheet #	QID	Plate	Vehicle Types Meaning	Insp Result	Insp Lvl	Fault Action	Fault Category	Fault desc	COF Expiry Date
15/06/2017	816151	RBC411	L402L	Trailer/caravan	Pass	5, 3	No Action			13/07/2017
15/06/2017	816151	RBC411	PHL11	Goods van/truck/utility	Fail	5, 3	Green 2 action	Load Anchorage	Bolster not securely fitted or attachment is damaged - no immediate risk of failure	13/07/2017
04/07/2017	816172	RBC411	PHL35	Goods van/truck/utility	Fail	3	Green 2 action	Lighting	Daytime running lamp works intermittently/operates with fog lights, not securely fitted or damaged	17/11/2017
04/07/2017	816172	RBC411	PHL35	Goods van/truck/utility	Fail	3	Green 2 action	Lighting	One required headlamp is not fitted, not securely attached or is not operational	17/11/2017
04/07/2017	816172	RBC411	T672A	Trailer/caravan	Pass	3	No Action			08/11/2017
05/07/2017	816174	RBC411	PHL08	Goods van/truck/utility	Fail	3	Green sticker	Lighting	One or more than two daytime running lamps fitted	30/11/2017
05/07/2017	816174	RBC411	U789M	Trailer/caravan	Fail	3	Green 2 action	Brakes	Air leaks any other system	21/12/2017
05/07/2017	816174	RBC411	U789M	Trailer/caravan	Fail	3	Pink sticker	Lighting	No stop lamps fitted, no stop lamps working, are excessively damaged or fully obscured. Single vehicle or rear unit of combo	21/12/2017
06/07/2017	818086	BWD335	PHL32	Goods van/truck/utility	Fail	5, 3	Green sticker	Exhaust System	Exhaust system not effective, loose, leaks or excessive noise	26/08/2017
06/07/2017	818086	BWD335	W198L	Trailer/caravan	Fail	5, 3	Green sticker	Lighting	One side indicator system does not operate	21/08/2017
17/07/2017	816188	RBC411	H469A	Trailer/caravan	Pass	3	No Action			03/12/2017
17/07/2017	816188	RBC411	PHL07	Goods van/truck/utility	Pass	3	No Action			16/12/2017
22/07/2017	768999	ATY330	7P447	Trailer/caravan	Pass	5	No Action			12/01/2018
22/07/2017	768999	ATY330	PHL37	Goods van/truck/utility	Pass	5	No Action			20/01/2018
01/08/2017	822421	RBC411	H469A	Trailer/caravan	Fail	5, 3	Green 2 action	Brakes	Air leaks any other system	03/12/2017
01/08/2017	822421	RBC411	PHL07	Goods van/truck/utility	Pass	5, 3	No Action			16/12/2017
11/08/2017	822440	RBC411	PHL13	Goods van/truck/utility	Fail	5, 3	Green 2 action	Brakes	Air leaks any other system	30/01/2018
22/08/2017	826921	RBC411	K898F	Trailer/caravan	Pass	5, 3	No Action			13/10/2017
22/08/2017	826921	RBC411	PHL05	Goods van/truck/utility	Fail	5, 3	Green 2 action	Lighting	One direction Indicator lamp not working	08/11/2017
05/09/2017	826949	RBC411	PHL35	Goods van/truck/utility	Pass	3	No Action			17/11/2017
05/09/2017	826949	RBC411	T672A	Trailer/caravan	Pass	3	No Action			08/11/2017
08/09/2017	826958	RBC411	L402L	Trailer/caravan	Fail	3	Pink sticker	Lighting	All side marker lamps not operational (during darkness)	13/01/2018
08/09/2017	826958	RBC411	L402L	Trailer/caravan	Fail	3	Pink sticker	Lighting	A rear tail lamp is not operational (during darkness) no other rear right lamp operational	13/01/2018
08/09/2017	826958	RBC411	PHL11	Goods van/truck/utility	Pass	3	No Action			13/01/2018

Insp Date	CVIR Sheet #	QID	Plate	Vehicle Types Meaning	Insp Result	Insp Lvl	Fault Action	Fault Category	Fault desc	COF Expiry Date
11/09/2017	830316	RBC411	PHL01	Goods van/truck/utility	Pass	3	No Action			04/11/2017
03/10/2017	832193	GGI670	PHL23	Goods van/truck/utility	Fail	5, 3	Green 2 action	Load Anchorage	Bolster not securely fitted or attachment is damaged - no immediate risk of failure	21/11/2017
03/10/2017	832193	GGI670	Q884L	Trailer/caravan	Fail	5, 3	Green sticker	Brakes	Stroke of brake chamber exceeds manufacturer's limit - service brake performance doesn't meet legal requirements	30/10/2017
03/10/2017	828698	GME708	J880M	Trailer/caravan	Pass	5, 3	No Action			22/12/2017
03/10/2017	828698	GME708	PHL29	Goods van/truck/utility	Pass	5, 3	No Action			21/12/2017
03/10/2017	833892	PJAT18	M829A	Trailer/caravan	Fail	5, 3	Pink sticker	Suspension	Leaf spring or coil spring broken, missing or seriously damaged.	03/04/2018
03/10/2017	833892	PJAT18	PHL12	Goods van/truck/utility	Fail	5, 3	Pink sticker	Brakes	Park brake actuator missing/not operational/does not lock into position, remains applied when released, is not securely fastened & may detach. Risk of inadvertent release	24/10/2017
03/10/2017	830350	RBC411	7B837	Trailer/caravan	Fail	5, 3	Green 2 action	Cab, Chassis and Body	Load containment structure damaged or not securely fitted - risk of failure, vehicle unloaded (includes cab guard)	28/10/2017
03/10/2017	830350	RBC411	PHL25	Goods van/truck/utility	Pass	5, 3	No Action			02/11/2017
03/10/2017	833895	PJAT18	5W717	Trailer/caravan	Pass	5, 3	No Action			31/10/2017
03/10/2017	833895	PJAT18	PHL27	Goods van/truck/utility	Pass	5, 3	No Action			19/10/2017
04/10/2017	832202	GGI670	J880M	Trailer/caravan	Fail	5, 3	Pink sticker	Wheels and Tyres	A tyre is damaged - operation affected and/or failure imminent	22/12/2017
04/10/2017	832202	GGI670	PHL29	Goods van/truck/utility	Pass	5, 3	No Action			21/12/2017
04/10/2017	832205	GGI670	PHL20	Goods van/truck/utility	Pass	5, 3	No Action			06/03/2018
04/10/2017	832205	GGI670	T674A	Trailer/caravan	Pass	5, 3	No Action			07/03/2018
04/10/2017	832209	GGI670	GDU506	Goods van/truck/utility	Pass	5, 3	No Action			05/12/2017
04/10/2017	832209	GGI670	S532N	Trailer/caravan	Pass	5, 3	No Action			20/12/2017
04/10/2017	832115	GME708	7K728	Trailer/caravan	Pass	5, 3	No Action			21/12/2017
04/10/2017	832115	GME708	PHL38	Goods van/truck/utility	Pass	5, 3	No Action			22/11/2017
04/10/2017	830360	RBC411	K239N	Trailer/caravan	Pass	5, 3	No Action			30/03/2018
04/10/2017	830360	RBC411	PHL10	Goods van/truck/utility	Pass	5, 3	No Action			30/03/2018
05/10/2017	834833	NRV683	PHL35	Goods van/truck/utility	Fail	5, 3	Green 2 action	Lighting	A headlamp is damaged failure is imminent or light output on either side is not approx equal	17/11/2017
05/10/2017	834833	NRV683	T672A	Trailer/caravan	Fail	5, 3	Green 2 action	PSV Wheels and Tyres	Tread in dual set 1 tyre below minimum	08/11/2017



Insp Date	CVIR Sheet #	QID	Plate	Vehicle Types Meaning	Insp Result	Insp Lvl	Fault Action	Fault Category	Fault desc	COF Expiry Date
05/10/2017	836073	PJAT18	PHL22	Goods van/truck/utility	Fail	5, 3	Pink sticker	Brakes	Park brake actuator missing/not operational/does not lock into position, remains applied when released, is not securely fastened & may detach. Risk of inadvertent release	26/01/2018
05/10/2017	836073	PJAT18	R462K	Trailer/caravan	Pass	5, 3	No Action			26/01/2018
11/10/2017	833637	RBC411	H469A	Trailer/caravan	Fail	3	Green 2 action	Brakes	Air leaks any other system	03/12/2017
11/10/2017	833637	RBC411	PHL07	Goods van/truck/utility	Pass	3	No Action			16/12/2017
19/10/2017	833650	RBC411	K438A	Trailer/caravan	Fail	3	Pink sticker	Wheels and Tyres	A tyre is damaged – operation affected and/or failure imminent	17/11/2017
19/10/2017	833650	RBC411	PHL04	Goods van/truck/utility	Fail	3	Green 2 action	Load Anchorage	Bolster not securely fitted or attachment is damaged – no immediate risk of failure	02/11/2017
01/11/2017	837227	RBC411	PHL36	Goods van/truck/utility	Fail	3	Green sticker	Lighting	Direction indicator lamp is damaged, fully obscured or output affected/failure imminent or is not securely fitted (detachment is imminent)	30/03/2018
02/11/2017	837235	RBC411	5W717	Trailer/caravan	Fail	3	Pink sticker	Lighting	No stop lamps fitted, no stop lamps working, are excessively damaged or fully obscured. Single vehicle or rear unit of combo	30/04/2018
02/11/2017	837235	RBC411	PHL27	Goods van/truck/utility	Fail	3	Green sticker	Lighting	One or more than two daytime running lamps fitted	19/04/2018
02/11/2017	837235	RBC411	PHL27	Goods van/truck/utility	Fail	3	Green 2 action	Lighting	A headlamp is damaged failure is imminent or light output on either side is not approx equal	19/04/2018
14/11/2017	814676	BLDA87	K438A	Trailer/caravan	Fail	5	Pink sticker	Lighting	No stop lamps fitted, no stop lamps working, are excessively damaged or fully obscured. Single vehicle or rear unit of combo	17/05/2018
14/11/2017	814676	BLDA87	PHL04	Goods van/truck/utility	Pass	5	No Action			02/05/2018
30/11/2017	837267	RBC411	K239N	Trailer/caravan	Fail	5, 3	Green 2 action	Lighting	Side marker lamp not operational, not secure, damaged or obscured	30/03/2018
30/11/2017	837267	RBC411	PHL10	Goods van/truck/utility	Fail	5, 3	Green 2 action	Lighting	One or more front park lamps not operational (anytime)	30/03/2018
05/12/2017	839682	RBC411	PHL10	Goods van/truck/utility	Fail	3	Green 2 action	Lighting	One or more front park lamps not operational (anytime)	30/03/2018
05/12/2017	839683	RBC411	PHL04	Goods van/truck/utility	Pass	3	No Action			02/05/2018
11/01/2018	841627	BWD335	PHL16	Goods van/truck/utility	Fail	5, 3	Green sticker	Mudguards	One mudguard missing/does not comply or a mudflap not fitted to a twin tyred axle	26/07/2018
11/01/2018	841627	BWD335	PHL16	Goods van/truck/utility	Fail	5, 3	Pink sticker	Wheels and Tyres	A tyre is damaged – operation affected and/or failure imminent	26/07/2018

Insp Date	CVIR Sheet #	QID	Plate	Vehicle Types Meaning	Insp Result	Insp Lvl	Fault Action	Fault Category	Fault desc	COF Expiry Date
11/01/2018	841627	BWD335	S25E	Trailer/caravan	Pass	5, 3	No Action			26/07/2018
18/01/2018	837646	BLDA87	6Y910	Trailer/caravan	Pass	5	No Action			18/01/2018
18/01/2018	837646	BLDA87	PHL36	Goods van/truck/utility	Pass	5	No Action			18/01/2018
08/02/2018	843246	BLDA87	PHL31	Goods van/truck/utility	Fail	5	Green 2 action	Lighting	A headlamp is damaged failure is imminent or light output on either side is not approx equal	18/06/2018
08/02/2018	843246	BLDA87	W970G	Trailer/caravan	Pass	5	No Action			18/06/2018
27/02/2018	854254	BWD335	PHL06	Goods van/truck/utility	Pass	5, 3	No Action			26/05/2018
27/02/2018	854254	BWD335	Z505Y	Trailer/caravan	Pass	5, 3	No Action			21/05/2018
03/04/2018	854929	RBC411	PHL26	Goods van/truck/utility	Pass	3	No Action			01/08/2018
13/04/2018	850703	BLDA87	PHL02	Goods van/truck/utility	Fail	5	Green 2 action	Wheels and Tyres	1 wheel nut loose/missing, 1 stud damaged/missing	07/10/2018
13/04/2018	850703	BLDA87	R177T	Trailer/caravan	Pass	5	No Action			07/10/2018
16/04/2018	854940	RBC411	P352C	Trailer/caravan	Pass	3	No Action			20/09/2018
16/04/2018	854940	RBC411	PHL15	Goods van/truck/utility	Fail	3	Green 2 action	Load Anchorage	Bolster not securely fitted or attachment is damaged – no immediate risk of failure	01/09/2018
26/04/2018	857314	RBC411	PHL02	Goods van/truck/utility	Pass	3	No Action			07/10/2018
26/04/2018	857314	RBC411	R177T	Trailer/caravan	Fail	3	Green 2 action	Lighting	One required rear reflector fitted, not securely fitted, colour other than red, anytime	07/10/2018
03/05/2018	854337	BWD335	PHL18	Goods van/truck/utility	Pass	5, 3	No Action			08/11/2018
11/05/2018	850731	BLDA87	PHL29	Goods van/truck/utility	Pass	5	No Action			21/06/2018
11/05/2018	850731	BLDA87	U789M	Trailer/caravan	Pass	5	No Action			21/06/2018
17/05/2018	850732	BLDA87	PHL23	Goods van/truck/utility	Pass	5	No Action			21/11/2018
20/06/2018	857357	RBC411	PHL32	Goods van/truck/utility	Pass	3	No Action			26/08/2018
20/06/2018	857358	RBC411	PHL27	Goods van/truck/utility	Fail	3	Pink sticker	Lighting	No stop lamps fitted, no stop lamps working, are excessively damaged or fully obscured. Single vehicle or rear unit of combo	19/10/2018
20/06/2018	857359	RBC411	GDU506	Goods van/truck/utility	Fail	3	Green 2 action	Lighting	Daytime running lamp works intermittently/operates with fog lights, not securely fitted or damaged	06/12/2018
25/06/2018	861239	RBC411	PHL20	Goods van/truck/utility	Fail	3	Green 2 action	Lighting	A fog lamp is insecure, damaged or out of alignment	07/09/2018
25/06/2018	861239	RBC411	PHL20	Goods van/truck/utility	Fail	3	Green 2 action	Lighting	One direction Indicator lamp not working	07/09/2018
25/06/2018	861239	RBC411	PHL20	Goods van/truck/utility	Fail	3	Green 2 action	Lighting	One required rear reflector fitted, not securely fitted, colour other than red, anytime	07/09/2018

Insp Date	CVIR Sheet #	QID	Plate	Vehicle Types Meaning	Insp Result	Insp Lvl	Fault Action	Fault Category	Fault desc	COF Expiry Date
25/06/2018	861240	RBC411	PHL02	Goods van/truck/utility	Fail	3	Green sticker	Lighting	Direction indicator lamp is damaged, fully obscured or output affected/failure imminent or is not securely fitted (detachment is imminent)	07/10/2018
25/06/2018	861241	RBC411	PHL12	Goods van/truck/utility	Fail	3	Green 2 action	Lighting	One direction Indicator lamp not working	24/10/2018
25/06/2018	861241	RBC411	PHL12	Goods van/truck/utility	Fail	3	Green 2 action	Lighting	One or more front park lamps not operational (anytime)	24/10/2018
07/07/2018	861259	RBC411	7P447	Trailer/caravan	Pass	3	No Action			06/01/2019
07/07/2018	861259	RBC411	PHL37	Goods van/truck/utility	Pass	3	No Action			06/01/2019
13/07/2018	861267	RBC411	PHL37	Goods van/truck/utility	Fail	3	Green sticker	Mudguards	One mudguard missing/does not comply or a mudflap not fitted to a twin tyred axle	06/01/2019
17/07/2018	861276	RBC411	PHL07	Goods van/truck/utility	Fail	3	Green 2 action	Lighting	Stop lamp emits colour other than red, or is obscured	16/12/2018
10/08/2018	867923	RBC411	PHL02	Goods van/truck/utility	Pass	2	No Action			07/10/2018
10/08/2018	867923	RBC411	R177T	Trailer/caravan	Fail	2	Pink sticker	Load Anchorage	Sliding bolster – no locking mechanism	07/10/2018
10/08/2018	867923	RBC411	R177T	Trailer/caravan	Fail	2	Green 2 action	Lighting	One direction Indicator lamp not working	07/10/2018
10/08/2018	867925	RBC411	GDU506	Goods van/truck/utility	Fail	3	Green 2 action	Lighting	Daytime running lamp works intermittently/operates with fog lights, not securely fitted or damaged	06/12/2018
16/08/2018	872864	RBC411	M829A	Trailer/caravan	Fail	3	Green 2 action	Lighting	One required rear reflector fitted, not securely fitted, colour other than red, anytime	03/10/2018
16/08/2018	872864	RBC411	PHL12	Goods van/truck/utility	Pass	3	No Action			24/10/2018
17/08/2018	872868	RBC411	9Z516	Trailer/caravan	Pass	3	No Action			24/01/2019
17/08/2018	872868	RBC411	PHL43	Goods van/truck/utility	Pass	3	No Action			24/01/2019
17/09/2018	872898	RBC411	PHL01	Goods van/truck/utility	Pass	5, 3	No Action			04/11/2018
17/09/2018	872898	RBC411	Z760L	Trailer/caravan	Fail	5, 3	Pink sticker	Lighting	No stop lamps fitted, no stop lamps working, are excessively damaged or fully obscured. Single vehicle or rear unit of combo	23/10/2018
27/09/2018	097707	RBC411	PHL05	Goods van/truck/utility	Fail	5, 3	Green 2 action	Lighting	One required headlamp is not fitted, not securely attached or is not operational	02/11/2018
03/10/2018	114451	RBC411	PHL30	Goods van/truck/utility	Pass	5, 3	No Action			04/03/2019
03/10/2018	114451	RBC411	R443P	Trailer/caravan	Fail	5, 3	Pink sticker	Load Anchorage	Sliding bolster – no locking mechanism	02/03/2019
26/10/2018	105572	BWD335	K898F	Trailer/caravan	Fail	5, 3	Pink sticker	Lighting	No stop lamps fitted, no stop lamps working, are excessively damaged or fully obscured. Single vehicle or rear unit of combo	13/04/2019
26/10/2018	105572	BWD335	PHL05	Goods van/truck/utility	Pass	5, 3	No Action			02/05/2019

Insp Date	CVIR Sheet #	QID	Plate	Vehicle Types Meaning	Insp Result	Insp Lvl	Fault Action	Fault Category	Fault desc	COF Expiry Date
30/10/2018	105582	BWD335	PHL12	Goods van/truck/utility	Pass	5, 3	No Action			24/04/2019
08/11/2018	114485	RBC411	PHL06	Goods van/truck/utility	Pass	5, 3	No Action			26/11/2018
08/11/2018	114485	RBC411	Z505Y	Trailer/caravan	Pass	5, 3	No Action			21/11/2018
12/11/2018	117905	JB227	PHL32	Goods van/truck/utility	Fail	5, 3	Green sticker	Exhaust System	Exhaust system not effective, loose, leaks or excessive noise	26/02/2019
12/11/2018	117905	JB227	W198L	Trailer/caravan	Fail	5, 3	Pink sticker	Brakes	ABS/EBS system is not operating - Combination vehicle	21/02/2019
13/11/2018	117057	BWD335	9Z511	Trailer/caravan	Pass	5, 3	No Action			13/01/2019
13/11/2018	117057	BWD335	PHL42	Goods van/truck/utility	Pass	5, 3	No Action			13/01/2019
13/11/2018	117159	WHG676	PHL16	Goods van/truck/utility	Pass	5, 3	No Action			26/01/2019
13/11/2018	117159	WHG676	S25E	Trailer/caravan	Pass	5, 3	No Action			26/01/2019
13/11/2018	114496	RBC411	PHL35	Goods van/truck/utility	Fail	5, 3	Green sticker	Brakes	Spring brake/electric brake control for parking brakes not protected from inadvertent release	17/05/2019
13/11/2018	114496	RBC411	T672A	Trailer/caravan	Pass	5, 3	No Action			08/05/2019
13/11/2018	105599	BWD335	6Y910	Trailer/caravan	Fail	5, 3	Green 2 action	Brakes	Suzie coil hose does not comply, support spring missing/ineffective	19/03/2019
13/11/2018	105599	BWD335	PHL36	Goods van/truck/utility	Pass	5, 3	No Action			14/03/2019
13/11/2018	114499	RBC411	K898F	Trailer/caravan	Fail	5, 3	Green 2 action	Load Anchorage	Bolster not securely fitted or attachment is damaged – no immediate risk of failure	13/04/2019
13/11/2018	114499	RBC411	PHL05	Goods van/truck/utility	Fail	5, 3	Green sticker	Brakes	Spring brake/electric brake control for parking brakes not protected from inadvertent release	02/05/2019
13/11/2018	114499	RBC411	PHL05	Goods van/truck/utility	Fail	5, 3	Pink sticker	Wheels and Tyres	Wheel nuts loose/missing or studs damaged/missing - safety risk	02/05/2019
14/11/2018	117925	JB227	PHL23	Goods van/truck/utility	Pass	5, 3	No Action			21/05/2019
14/11/2018	117925	JB227	Q884L	Trailer/caravan	Fail	5, 3	Pink sticker	Suspension	Suspension component not fitted/not securely fitted	30/04/2019
14/11/2018	117925	JB227	Q884L	Trailer/caravan	Fail	5, 3	Green 2 action	Wheels and Tyres	Tyre not correctly inflated – operation/control not affected	30/04/2019
14/11/2018	114553	RBC411	PHL2O	Goods van/truck/utility	Fail	5, 3	Green sticker	Brakes	Spring brake/electric brake control for parking brakes not protected from inadvertent release	07/03/2019
14/11/2018	114553	RBC411	PHL2O	Goods van/truck/utility	Fail	5, 3	Green sticker	Suspension	Shock absorber missing, damaged or leaking excessively (wet or dripping)	07/03/2019
14/11/2018	114553	RBC411	T674A	Trailer/caravan	Fail	5, 3	Pink sticker	Brakes	Air leak low air pressure <30 seconds	07/03/2019
14/11/2018	114553	RBC411	T674A	Trailer/caravan	Fail	5, 3	Green 2 action	Load Anchorage	Bolster not securely fitted or attachment is damaged – no immediate risk of failure	07/03/2019

Insp Date	CVIR Sheet #	QID	Plate	Vehicle Types Meaning	Insp Result	Insp Lvl	Fault Action	Fault Category	Fault desc	COF Expiry Date
14/11/2018	114556	RBC411	6F838	Trailer/caravan	Fail	5, 3	Green 2 action	Brakes	Suzie coil hose does not comply, support spring missing/ineffective	18/01/2019
14/11/2018	114556	RBC411	6F838	Trailer/caravan	Fail	5, 3	Pink sticker	Brakes	ABS/EBS system is not operating - Combination vehicle	18/01/2019
14/11/2018	114556	RBC411	6F838	Trailer/caravan	Fail	5, 3	Green 2 action	Lighting	One required rear reflector fitted, not securely fitted, colour other than red, anytime	18/01/2019
14/11/2018	114556	RBC411	6F838	Trailer/caravan	Fail	5, 3	Green 2 action	Ball-race Turntables	Ball-race turntable fasteners loose (other)	18/01/2019
14/11/2018	114556	RBC411	PHL28	Goods van/truck/utility	Fail	5, 3	Green 2 action	Lighting	Daytime running lamp works intermittently/operates with fog lights, not securely fitted or damaged	18/01/2019
14/11/2018	114556	RBC411	PHL28	Goods van/truck/utility	Fail	5, 3	Green 2 action	Lighting	One required headlamp is not fitted, not securely attached or is not operational	18/01/2019
14/11/2018	117929	JB227	PHL18	Goods van/truck/utility	Pass	5, 3	No Action			08/05/2019
14/11/2018	117929	JB227	R179F	Trailer/caravan	Pass	5, 3	No Action			24/05/2019
14/11/2018	114558	RBC411	N102T	Trailer/caravan	Fail	5, 3	Green 2 action	Lighting	One direction Indicator lamp not working	30/04/2019
14/11/2018	114558	RBC411	PHL14	Goods van/truck/utility	Fail	5, 3	Green sticker	Brakes	Spring brake/electric brake control for parking brakes not protected from inadvertent release	30/04/2019
14/11/2018	114558	RBC411	PHL14	Goods van/truck/utility	Fail	5, 3	Green sticker	Exhaust System	Exhaust system not effective, loose, leaks or excessive noise	30/04/2019
14/11/2018	114558	RBC411	PHL14	Goods van/truck/utility	Fail	5, 3	Green 2 action	Fluid Leaks	Fluid leaks other	30/04/2019
15/11/2018	117173	WHG676	4Z305	Trailer/caravan	Pass	5, 3	No Action			01/02/2019
15/11/2018	117173	WHG676	PHL26	Goods van/truck/utility	Pass	5, 3	No Action			01/02/2019
15/11/2018	117175	WHG676	5W717	Trailer/caravan	Fail	5, 3	Green sticker	Brakes	Stroke of brake chamber exceeds manufacturer's limit - service brake performance doesn't meet legal requirements	30/04/2019
15/11/2018	117175	WHG676	PHL27	Goods van/truck/utility	Pass	5, 3	No Action			19/04/2019
15/11/2018	114567	RBC411	PHL34	Goods van/truck/utility	Pass	5, 3	No Action			27/02/2019
15/11/2018	114567	RBC411	Y951K	Trailer/caravan	Fail	5, 3	Green sticker	Brakes	Air leak low air pressure >30 seconds	28/02/2019
15/11/2018	114567	RBC411	Y951K	Trailer/caravan	Fail	5, 3	Green sticker	Brakes	Reservoir/master cylinder/servo unit leaks, or is loose/otherwise damaged or worn	28/02/2019
15/11/2018	121785	WDJ177	9Z506	Trailer/caravan	Pass	5, 3	No Action			09/06/2019
15/11/2018	121785	WDJ177	PHL41	Goods van/truck/utility	Pass	5, 3	No Action			17/05/2019
15/11/2018	121783	WDJ177	PHL02	Goods van/truck/utility	Pass	5, 3	No Action			08/04/2019
15/11/2018	121783	WDJ177	R177T	Trailer/caravan	Fail	5, 3	Pink sticker	Wheels and Tyres	Side wall unzipping	08/04/2019

Insp Date	CVIR Sheet #	QID	Plate	Vehicle Types Meaning	Insp Result	Insp Lvl	Fault Action	Fault Category	Fault desc	COF Expiry Date
15/11/2018	117941	JB227	9Z516	Trailer/caravan	Pass	5, 3	No Action			24/01/2019
15/11/2018	117941	JB227	PHL43	Goods van/truck/utility	Pass	5, 3	No Action			24/01/2019
26/11/2018	114589	RBC411	4Z305	Trailer/caravan	Pass	5, 3	No Action			01/02/2019
26/11/2018	114589	RBC411	PHL26	Goods van/truck/utility	Pass	5, 3	No Action			01/02/2019
03/12/2018	114599	RBC411	PHL33	Goods van/truck/utility	Fail	5, 3	Green sticker	Brakes	Spring brake/electric brake control for parking brakes not protected from inadvertent release	03/04/2019
03/12/2018	114599	RBC411	PHL33	Goods van/truck/utility	Fail	5, 3	Green 2 action	Lighting	One required headlamp is not fitted, not securely attached or is not operational	03/04/2019
03/12/2018	123554	RBC411	PHL09	Goods van/truck/utility	Pass	5, 3	No Action			25/03/2019
03/12/2018	123554	RBC411	Z745L	Trailer/caravan	Pass	5, 3	No Action			24/03/2019
12/12/2018	107316	PNIQ51	4Z305	Trailer/caravan	Pass	5, 3	No Action			01/02/2019
12/12/2018	107316	PNIQ51	PHL26	Goods van/truck/utility	Pass	5, 3	No Action			01/02/2019
12/12/2018	107318	PNIQ51	PHL20	Goods van/truck/utility	Pass	5, 3	No Action			07/03/2019
12/12/2018	107318	PNIQ51	T674A	Trailer/caravan	Fail	5, 3	Pink sticker	Suspension	Air bag damaged/fully deflated – laden	07/03/2019
13/12/2018	107324	PNIQ51	7B837	Trailer/caravan	Fail	5, 3	Pink sticker	Brakes	Air brake pipe, hose, connector or component leaking - audible air leak from a pipe, hose, connector or component.	29/04/2019
13/12/2018	107324	PNIQ51	7B837	Trailer/caravan	Fail	5, 3	Green sticker	Ball-race Turntables	Ball-race turntable bolts loose – up to 25% (max 3)	29/04/2019
13/12/2018	107324	PNIQ51	PHL25	Goods van/truck/utility	Pass	5, 3	No Action			02/05/2019
18/12/2018	107332	PNIQ51	8K642	Trailer/caravan	Pass	5, 3	No Action			29/05/2019
18/12/2018	107332	PNIQ51	PHL13	Goods van/truck/utility	Pass	5, 3	No Action			15/06/2019
19/12/2018	123569	RBC411	PHL30	Goods van/truck/utility	Fail	5, 3	Green 2 action	Fluid Leaks	Fluid leaks other	04/03/2019
19/12/2018	123569	RBC411	R443P	Trailer/caravan	Fail	5, 3	Pink sticker	Suspension	Suspension component not fitted/not securely fitted	02/03/2019
19/12/2018	123569	RBC411	R443P	Trailer/caravan	Fail	5, 3	Green 2 action	Wheels and Tyres	A tyre is damaged/imbedded object – operation not affected	02/03/2019
05/02/2019	123590	RBC411	K898F	Trailer/caravan	Fail	6, 3	Green 2 action	Lighting	A rear tail lamp is not operating, damaged or fully obscured	13/04/2019
05/02/2019	123590	RBC411	K898F	Trailer/caravan	Fail	6, 3	Green 2 action	Suspension	Axle locating device loose – includes loose “U” bolts	13/04/2019
05/02/2019	123590	RBC411	PHL05	Goods van/truck/utility	Fail	6, 3	Green 2 action	Lighting	A headlamp is damaged failure is imminent or light output on either side is not approx equal	02/05/2019
08/02/2019	123597	RBC411	P352C	Trailer/caravan	Pass	5, 3	No Action			10/09/2019

Insp Date	CVIR Sheet #	QID	Plate	Vehicle Types Meaning	Insp Result	Insp Lvl	Fault Action	Fault Category	Fault desc	COF Expiry Date
08/02/2019	123597	RBC411	PHL15	Goods van/truck/utility	Pass	5, 3	No Action			01/09/2019
14/02/2019	107362	PNIQ51	7P447	Trailer/caravan	Pass	5, 3	No Action			01/07/2019
14/02/2019	107362	PNIQ51	PHL37	Goods van/truck/utility	Pass	5, 3	No Action			01/07/2019
19/02/2019	126815	RBC411	7K728	Trailer/caravan	Pass	5, 3	No Action			07/06/2019
19/02/2019	126815	RBC411	PHL38	Goods van/truck/utility	Pass	5, 3	No Action			22/05/2019
19/02/2019	126816	RBC411	PHL01	Goods van/truck/utility	Pass	5, 3	No Action			04/05/2019
19/02/2019	126816	RBC411	Z760L	Trailer/caravan	Pass	5, 3	No Action			23/04/2019
20/02/2019	126823	RBC411	PHL06	Goods van/truck/utility	Fail	5, 3	Green 2 action	Lighting	Side marker lamp not operational, not secure, damaged or obscured	26/05/2019
20/02/2019	126823	RBC411	Z505Y	Trailer/caravan	Pass	5, 3	No Action			21/05/2019
21/02/2019	126828	RBC411	PHL35	Goods van/truck/utility	Pass	5, 3	No Action			17/05/2019
21/02/2019	126828	RBC411	T672A	Trailer/caravan	Fail	5, 3	Pink sticker	Brakes	Air brake pipe, hose, connector or component leaking - audible air leak from a pipe, hose, connector or component.	08/05/2019
21/02/2019	126829	RBC411	PHL02	Goods van/truck/utility	Pass	5, 3	No Action			08/04/2019
21/02/2019	126829	RBC411	R177T	Trailer/caravan	Fail	5, 3	Pink sticker	Lighting	No stop lamps fitted, no stop lamps working, are excessively damaged or fully obscured. Single vehicle or rear unit of combo	08/04/2019
21/02/2019	126829	RBC411	R177T	Trailer/caravan	Fail	5, 3	Pink sticker	Lighting	Whole indicator system does not operate	08/04/2019
21/02/2019	126829	RBC411	R177T	Trailer/caravan	Fail	5, 3	Green 2 action	Lighting	Side marker lamp not operational, not secure, damaged or obscured	08/04/2019
21/02/2019	126829	RBC411	R177T	Trailer/caravan	Fail	5, 3	Green 2 action	Lighting	A rear tail lamp is not operating, damaged or fully obscured	08/04/2019
27/02/2019	126839	RBC411	4Z305	Trailer/caravan	Fail	5, 3	Green sticker	Suspension	Shock absorber missing, damaged or leaking excessively (wet or dripping)	26/07/2019
27/02/2019	126839	RBC411	PHL26	Goods van/truck/utility	Pass	5, 3	No Action			26/07/2019

Total Vehicles Inspected:	188	Fault Action	Total	Vehicle Action	Total
Total Faults:	112	Pink sticker	29	Compliance	9
Total Fails:	82	Green sticker	22	No Action	105
Total Passes:	106	Green 2 action	61	Ordered to comply/Green 2	2
Total Fault Actions:	112	No Action	106	Pink	1
Avg No Faults per Vehicle:	0.60		218	Roadside Remedy	20
Avg No. Faults per Failed Vehicle:	1.37			Verbal Direction	51
					188

### Inspections by Driver

DL Number: s9(2)(a)

Driver: s9(2)(a)

Insp Date	CVIR Sheet #	QID	Plate	Vehicle Types Meaning	Insp Result	Insp Lvl	Fault Action	Fault Category	Fault desc	COF Expiry Date
08/02/2018	843246	BLDA87	PHL31	Goods van/truck/utility	Fail	5	Green 2 action	Lighting	A headlamp is damaged failure is imminent or light output on either side is not approx equal	18/06/2018
08/02/2018	843246	BLDA87	W970G	Trailer/caravan	Pass	5	No Action			18/06/2018
30/10/2018	105582	BWD335	PHL12	Goods van/truck/utility	Pass	5, 3	No Action			24/04/2019

DL Number: s9(2)(a)

Driver: s9(2)(a)

Insp Date	CVIR Sheet #	QID	Plate	Vehicle Types Meaning	Insp Result	Insp Lvl	Fault Action	Fault Category	Fault desc	COF Expiry Date
16/05/2017	815293	BWD335	PHL34	Goods van/truck/utility	Pass	5, 3	No Action			27/08/2017
16/05/2017	815293	BWD335	Y951K	Trailer/caravan	Pass	5, 3	No Action			28/08/2017
15/11/2018	114567	RBC411	PHL34	Goods van/truck/utility	Pass	5, 3	No Action			27/02/2019
15/11/2018	114567	RBC411	Y951K	Trailer/caravan	Fail	5, 3	Green sticker	Brakes	Air leak low air pressure >30 seconds	28/02/2019
15/11/2018	114567	RBC411	Y951K	Trailer/caravan	Fail	5, 3	Green sticker	Brakes	Reservoir/master cylinder/servo unit leaks, or is loose/otherwise damaged or worn	28/02/2019



DL Number: s9(2)(a)

Driver: s9(2)(a)

Insp Date	CVIR Sheet #	QID	Plate	Vehicle Types Meaning	Insp Result	Insp Lvl	Fault Action	Fault Category	Fault desc	COF Expiry Date
15/03/2017	801635	BWD335	PHL06	Goods van/truck/utility	Pass	5, 3	No Action			26/05/2017
15/03/2017	801635	BWD335	Z505Y	Trailer/caravan	Fail	5, 3	Pink sticker	Suspension	Suspension component not fitted/not securely fitted	21/05/2017

DL Number: s9(2)(a)

Driver: s9(2)(a)

Insp Date	CVIR Sheet #	QID	Plate	Vehicle Types Meaning	Insp Result	Insp Lvl	Fault Action	Fault Category	Fault desc	COF Expiry Date
13/11/2018	114496	RBC411	PHL35	Goods van/truck/utility	Fail	5, 3	Green sticker	Brakes	Spring brake/electric brake control for parking brakes not protected from inadvertent release	17/05/2019
13/11/2018	114496	RBC411	T672A	Trailer/caravan	Pass	5, 3	No Action			08/05/2019
21/02/2019	126828	RBC411	PHL35	Goods van/truck/utility	Pass	5, 3	No Action			17/05/2019
21/02/2019	126828	RBC411	T672A	Trailer/caravan	Fail	5, 3	Pink sticker	Brakes	Air brake pipe, hose, connector or component leaking - audible air leak from a pipe, hose, connector or component.	08/05/2019

DL Number: s9(2)(a)

Driver: s9(2)(a)

Insp Date	CVIR Sheet #	QID	Plate	Vehicle Types Meaning	Insp Result	Insp Lvl	Fault Action	Fault Category	Fault desc	COF Expiry Date
06/07/2017	818086	BWD335	PHL32	Goods van/truck/utility	Fail	5, 3	Green sticker	Exhaust System	Exhaust system not effective, loose, leaks or excessive noise	26/08/2017
06/07/2017	818086	BWD335	W198L	Trailer/caravan	Fail	5, 3	Green sticker	Lighting	One side indicator system does not operate	21/08/2017

DL Number: s9(2)(a)

Driver: s9(2)(a)

Insp Date	CVIR Sheet #	QID	Plate	Vehicle Types Meaning	Insp Result	Insp Lvl	Fault Action	Fault Category	Fault desc	COF Expiry Date
19/10/2017	833650	RBC411	K438A	Trailer/caravan	Fail	3	Pink sticker	Wheels and Tyres	A tyre is damaged – operation affected and/or failure imminent	17/11/2017
19/10/2017	833650	RBC411	PHL04	Goods van/truck/utility	Fail	3	Green 2 action	Load Anchorage	Bolster not securely fitted or attachment is damaged – no immediate risk of failure	02/11/2017

DL Number: s9(2)(a)

Driver: s9(2)(a)

Insp Date	CVIR Sheet #	QID	Plate	Vehicle Types Meaning	Insp Result	Insp Lvl	Fault Action	Fault Category	Fault desc	COF Expiry Date
03/04/2017	810486	RBC411	PHL15	Goods van/truck/utility	Fail	3	Green 2 action	Lighting	One required headlamp is not fitted, not securely attached or is not operational	01/09/2017
03/04/2017	810486	RBC411	PHL15	Goods van/truck/utility	Fail	3	Green 2 action	Lighting	Direction indicator lamp is damaged, partially obscured output not affected or is loose.	01/09/2017
03/04/2017	810486	RBC411	PHL15	Goods van/truck/utility	Fail	3	Green 2 action	Lighting	A rear tail lamp is not operating, damaged or fully obscured	01/09/2017

DL Number: s9(2)(a)

Driver: s9(2)(a)

Insp Date	CVIR Sheet #	QID	Plate	Vehicle Types Meaning	Insp Result	Insp Lvl	Fault Action	Fault Category	Fault desc	COF Expiry Date
04/10/2017	832202	GGI670	J880M	Trailer/caravan	Fail	5, 3	Pink sticker	Wheels and Tyres	A tyre is damaged – operation affected and/or failure imminent	22/12/2017
04/10/2017	832202	GGI670	PHL29	Goods van/truck/utility	Pass	5, 3	No Action			21/12/2017
11/05/2018	850731	BLDA87	PHL29	Goods van/truck/utility	Pass	5	No Action			21/06/2018
11/05/2018	850731	BLDA87	U789M	Trailer/caravan	Pass	5	No Action			21/06/2018
14/11/2018	117929	JB227	PHL18	Goods van/truck/utility	Pass	5, 3	No Action			08/05/2019
14/11/2018	117929	JB227	R179F	Trailer/caravan	Pass	5, 3	No Action			24/05/2019

Released under the Official Information Act 1982

DL Number: s9(2)(a)

Driver: s9(2)(a)

Insp Date	CVIR Sheet #	QID	Plate	Vehicle Types Meaning	Insp Result	Insp Lvl	Fault Action	Fault Category	Fault desc	COF Expiry Date
15/11/2018	117173	WHG676	4Z305	Trailer/caravan	Pass	5, 3	No Action			01/02/2019
15/11/2018	117173	WHG676	PHL26	Goods van/truck/utility	Pass	5, 3	No Action			01/02/2019
26/11/2018	114589	RBC411	4Z305	Trailer/caravan	Pass	5, 3	No Action			01/02/2019
26/11/2018	114589	RBC411	PHL26	Goods van/truck/utility	Pass	5, 3	No Action			01/02/2019
12/12/2018	107316	PNIQ51	4Z305	Trailer/caravan	Pass	5, 3	No Action			01/02/2019
12/12/2018	107316	PNIQ51	PHL26	Goods van/truck/utility	Pass	5, 3	No Action			01/02/2019
27/02/2019	126839	RBC411	4Z305	Trailer/caravan	Fail	5, 3	Green sticker	Suspension	Shock absorber missing, damaged or leaking excessively (wet or dripping)	26/07/2019
27/02/2019	126839	RBC411	PHL26	Goods van/truck/utility	Pass	5, 3	No Action			26/07/2019

DL Number: s9(2)(a)

Driver: s9(2)(a)

Insp Date	CVIR Sheet #	QID	Plate	Vehicle Types Meaning	Insp Result	Insp Lvl	Fault Action	Fault Category	Fault desc	COF Expiry Date
31/05/2017	815336	BWD335	7B837	Trailer/caravan	Pass	5, 3	No Action			28/10/2017
31/05/2017	815336	BWD335	PHL25	Goods van/truck/utility	Fail	5, 3	Green 2 action	Brakes	Air leaks any other system	02/11/2017
03/10/2017	830350	RBC411	7B837	Trailer/caravan	Fail	5, 3	Green 2 action	Cab, Chassis and Body	Load containment structure damaged or not securely fitted - risk of failure, vehicle unloaded (includes cab guard)	28/10/2017
03/10/2017	830350	RBC411	PHL25	Goods van/truck/utility	Pass	5, 3	No Action			02/11/2017
13/12/2018	107324	PNIQ51	7B837	Trailer/caravan	Fail	5, 3	Pink sticker	Brakes	Air brake pipe, hose, connector or component leaking - audible air leak from a pipe, hose, connector or component.	29/04/2019
13/12/2018	107324	PNIQ51	7B837	Trailer/caravan	Fail	5, 3	Green sticker	Ball-race Turntables	Ball-race turntable bolts loose – up to 25% (max 3)	29/04/2019
13/12/2018	107324	PNIQ51	PHL25	Goods van/truck/utility	Pass	5, 3	No Action			02/05/2019

DL Number: s9(2)(a)

Driver: s9(2)(a)

Insp Date	CVIR Sheet #	QID	Plate	Vehicle Types Meaning	Insp Result	Insp Lvl	Fault Action	Fault Category	Fault desc	COF Expiry Date
03/10/2017	833892	PJAT18	M829A	Trailer/caravan	Fail	5, 3	Pink sticker	Suspension	Leaf spring or coil spring broken, missing or seriously damaged.	03/04/2018
03/10/2017	833892	PJAT18	PHL12	Goods van/truck/utility	Fail	5, 3	Pink sticker	Brakes	Park brake actuator missing/not operational/does not lock into position, remains applied when released, is not securely fastened & may detach. Risk of inadvertent release	24/10/2017
20/06/2018	857357	RBC411	PHL32	Goods van/truck/utility	Pass	3	No Action			26/08/2018
12/11/2018	117905	JB227	PHL32	Goods van/truck/utility	Fail	5, 3	Green sticker	Exhaust System	Exhaust system not effective, loose, leaks or excessive noise	26/02/2019
12/11/2018	117905	JB227	W198L	Trailer/caravan	Fail	5, 3	Pink sticker	Brakes	ABS/EBS system is not operating - Combination vehicle	21/02/2019

DL Number: s9(2)(a)

Driver: s9(2)(a)

Insp Date	CVIR Sheet #	QID	Plate	Vehicle Types Meaning	Insp Result	Insp Lvl	Fault Action	Fault Category	Fault desc	COF Expiry Date
17/07/2017	816188	RBC411	H469A	Trailer/caravan	Pass	3	No Action			03/12/2017
17/07/2017	816188	RBC411	PHL07	Goods van/truck/utility	Pass	3	No Action			16/12/2017
01/08/2017	822421	RBC411	H469A	Trailer/caravan	Fail	5, 3	Green 2 action	Brakes	Air leaks any other system	03/12/2017
01/08/2017	822421	RBC411	PHL07	Goods van/truck/utility	Pass	5, 3	No Action			16/12/2017
11/10/2017	833637	RBC411	H469A	Trailer/caravan	Fail	3	Green 2 action	Brakes	Air leaks any other system	03/12/2017
11/10/2017	833637	RBC411	PHL07	Goods van/truck/utility	Pass	3	No Action			16/12/2017
15/11/2018	121785	WDJ177	9Z506	Trailer/caravan	Pass	5, 3	No Action			09/06/2019
15/11/2018	121785	WDJ177	PHL41	Goods van/truck/utility	Pass	5, 3	No Action			17/05/2019

DL Number: s9(2)(a)

Driver: s9(2)(a)

Insp Date	CVIR Sheet #	QID	Plate	Vehicle Types Meaning	Insp Result	Insp Lvl	Fault Action	Fault Category	Fault desc	COF Expiry Date
11/04/2017	801923	BLDA87	PHL01	Goods van/truck/utility	Fail	5	Green 2 action	Fluid Leaks	Fluid leaks other	04/05/2017
11/04/2017	801923	BLDA87	Z760L	Trailer/caravan	Pass	5	No Action			23/04/2017
11/09/2017	830316	RBC411	PHL01	Goods van/truck/utility	Pass	3	No Action			04/11/2017

DL Number: s9(2)(a)

Driver: s9(2)(a)

Insp Date	CVIR Sheet #	QID	Plate	Vehicle Types Meaning	Insp Result	Insp Lvl	Fault Action	Fault Category	Fault desc	COF Expiry Date
22/08/2017	826921	RBC411	K898F	Trailer/caravan	Pass	5, 3	No Action			13/10/2017
22/08/2017	826921	RBC411	PHL05	Goods van/truck/utility	Fail	5, 3	Green 2 action	Lighting	One direction Indicator lamp not working	08/11/2017
27/09/2018	097707	RBC411	PHL05	Goods van/truck/utility	Fail	5, 3	Green 2 action	Lighting	One required headlamp is not fitted, not securely attached or is not operational	02/11/2018
26/10/2018	105572	BWD335	K898F	Trailer/caravan	Fail	5, 3	Pink sticker	Lighting	No stop lamps fitted, no stop lamps working, are excessively damaged or fully obscured. Single vehicle or rear unit of combo	13/04/2019
26/10/2018	105572	BWD335	PHL05	Goods van/truck/utility	Pass	5, 3	No Action			02/05/2019
13/11/2018	114499	RBC411	K898F	Trailer/caravan	Fail	5, 3	Green 2 action	Load Anchorage	Bolster not securely fitted or attachment is damaged – no immediate risk of failure	13/04/2019
13/11/2018	114499	RBC411	PHL05	Goods van/truck/utility	Fail	5, 3	Green sticker	Brakes	Spring brake/electric brake control for parking brakes not protected from inadvertent release	02/05/2019
13/11/2018	114499	RBC411	PHL05	Goods van/truck/utility	Fail	5, 3	Pink sticker	Wheels and Tyres	Wheel nuts loose/missing or studs damaged/missing - safety risk	02/05/2019
05/02/2019	123590	RBC411	K898F	Trailer/caravan	Fail	6, 3	Green 2 action	Lighting	A rear tail lamp is not operating, damaged or fully obscured	13/04/2019
05/02/2019	123590	RBC411	K898F	Trailer/caravan	Fail	6, 3	Green 2 action	Suspension	Axle locating device loose – includes loose "U" bolts	13/04/2019
05/02/2019	123590	RBC411	PHL05	Goods van/truck/utility	Fail	6, 3	Green 2 action	Lighting	A headlamp is damaged failure is imminent or light output on either side is not approx equal	02/05/2019

DL Number: s9(2)(a)

Driver: s9(2)(a)

Insp Date	CVIR Sheet #	QID	Plate	Vehicle Types Meaning	Insp Result	Insp Lvl	Fault Action	Fault Category	Fault desc	COF Expiry Date
07/07/2018	861259	RBC411	7P447	Trailer/caravan	Pass	3	No Action			06/01/2019
07/07/2018	861259	RBC411	PHL37	Goods van/truck/utility	Pass	3	No Action			06/01/2019
13/07/2018	861267	RBC411	PHL37	Goods van/truck/utility	Fail	3	Green sticker	Mudguards	One mudguard missing/does not comply or a mudflap not fitted to a twin tyred axle	06/01/2019
14/02/2019	107362	PNIQ51	7P447	Trailer/caravan	Pass	5, 3	No Action			01/07/2019
14/02/2019	107362	PNIQ51	PHL37	Goods van/truck/utility	Pass	5, 3	No Action			01/07/2019

DL Number: s9(2)(a)

Driver: s9(2)(a)

Insp Date	CVIR Sheet #	QID	Plate	Vehicle Types Meaning	Insp Result	Insp Lvl	Fault Action	Fault Category	Fault desc	COF Expiry Date
05/07/2017	816174	RBC411	PHL08	Goods van/truck/utility	Fail	3	Green sticker	Lighting	One or more than two daytime running lamps fitted	30/11/2017
05/07/2017	816174	RBC411	U789M	Trailer/caravan	Fail	3	Green 2 action	Brakes	Air leaks any other system	21/12/2017
05/07/2017	816174	RBC411	U789M	Trailer/caravan	Fail	3	Pink sticker	Lighting	No stop lamps fitted, no stop lamps working, are excessively damaged or fully obscured. Single vehicle or rear unit of combo	21/12/2017

DL Number: s9(2)(a)

Driver: s9(2)(a)

Insp Date	CVIR Sheet #	QID	Plate	Vehicle Types Meaning	Insp Result	Insp Lvl	Fault Action	Fault Category	Fault desc	COF Expiry Date
08/02/2019	123597	RBC411	P352C	Trailer/caravan	Pass	5, 3	No Action			10/09/2019
08/02/2019	123597	RBC411	PHL15	Goods van/truck/utility	Pass	5, 3	No Action			01/09/2019

Released under the Official Information Act 1982

DL Number: s9(2)(a)

Driver: s9(2)(a)

Insp Date	CVIR Sheet #	QID	Plate	Vehicle Types Meaning	Insp Result	Insp Lvl	Fault Action	Fault Category	Fault desc	COF Expiry Date
04/10/2017	830360	RBC411	K239N	Trailer/caravan	Pass	5, 3	No Action			30/03/2018
04/10/2017	830360	RBC411	PHL10	Goods van/truck/utility	Pass	5, 3	No Action			30/03/2018
30/11/2017	837267	RBC411	K239N	Trailer/caravan	Fail	5, 3	Green 2 action	Lighting	Side marker lamp not operational, not secure, damaged or obscured	30/03/2018
30/11/2017	837267	RBC411	PHL10	Goods van/truck/utility	Fail	5, 3	Green 2 action	Lighting	One or more front park lamps not operational (anytime)	30/03/2018
05/12/2017	839682	RBC411	PHL10	Goods van/truck/utility	Fail	3	Green 2 action	Lighting	One or more front park lamps not operational (anytime)	30/03/2018

DL Number: s9(2)(a)

Driver: s9(2)(a)

Insp Date	CVIR Sheet #	QID	Plate	Vehicle Types Meaning	Insp Result	Insp Lvl	Fault Action	Fault Category	Fault desc	COF Expiry Date
03/12/2018	123554	RBC411	PHL09	Goods van/truck/utility	Pass	5, 3	No Action			25/03/2019
03/12/2018	123554	RBC411	Z745L	Trailer/caravan	Pass	5, 3	No Action			24/03/2019

DL Number: s9(2)(a)

Driver: s9(2)(a)

Insp Date	CVIR Sheet #	QID	Plate	Vehicle Types Meaning	Insp Result	Insp Lvl	Fault Action	Fault Category	Fault desc	COF Expiry Date
05/10/2017	834833	NRY683	PHL35	Goods van/truck/utility	Fail	5, 3	Green 2 action	Lighting	A headlamp is damaged failure is imminent or light output on either side is not approx equal	17/11/2017
05/10/2017	834833	NRY683	T672A	Trailer/caravan	Fail	5, 3	Green 2 action	PSV Wheels and Tyres	Tread in dual set 1 tyre below minimum	08/11/2017
03/05/2018	854337	BWD335	PHL18	Goods van/truck/utility	Pass	5, 3	No Action			08/11/2018

DL Number: s9(2)(a)

Driver: s9(2)(a)

Insp Date	CVIR Sheet #	QID	Plate	Vehicle Types Meaning	Insp Result	Insp Lvl	Fault Action	Fault Category	Fault desc	COF Expiry Date
11/08/2017	822440	RBC411	PHL13	Goods van/truck/utility	Fail	5, 3	Green 2 action	Brakes	Air leaks any other system	30/01/2018

DL Number: s9(2)(a)

Driver: s9(2)(a)

Insp Date	CVIR Sheet #	QID	Plate	Vehicle Types Meaning	Insp Result	Insp Lvl	Fault Action	Fault Category	Fault desc	COF Expiry Date
14/11/2018	114558	RBC411	N102T	Trailer/caravan	Fail	5, 3	Green 2 action	Lighting	One direction Indicator lamp not working	30/04/2019
14/11/2018	114558	RBC411	PHL14	Goods van/truck/utility	Fail	5, 3	Green sticker	Brakes	Spring brake/electric brake control for parking brakes not protected from inadvertent release	30/04/2019
14/11/2018	114558	RBC411	PHL14	Goods van/truck/utility	Fail	5, 3	Green sticker	Exhaust System	Exhaust system not effective, loose, leaks or excessive noise	30/04/2019
14/11/2018	114558	RBC411	PHL14	Goods van/truck/utility	Fail	5, 3	Green 2 action	Fluid Leaks	Fluid leaks other	30/04/2019

DL Number: s9(2)(a)

Driver: s9(2)(a)

Insp Date	CVIR Sheet #	QID	Plate	Vehicle Types Meaning	Insp Result	Insp Lvl	Fault Action	Fault Category	Fault desc	COF Expiry Date
03/10/2017	832193	GGI670	PHL23	Goods van/truck/utility	Fail	5, 3	Green 2 action	Load Anchorage	Bolster not securely fitted or attachment is damaged – no immediate risk of failure	21/11/2017
03/10/2017	832193	GGI670	Q884L	Trailer/caravan	Fail	5, 3	Green sticker	Brakes	Stroke of brake chamber exceeds manufacturer's limit - service brake performance doesn't meet legal requirements	30/10/2017
17/05/2018	850732	BLDA87	PHL23	Goods van/truck/utility	Pass	5	No Action			21/11/2018
03/12/2018	114599	RBC411	PHL33	Goods van/truck/utility	Fail	5, 3	Green sticker	Brakes	Spring brake/electric brake control for parking brakes not protected from inadvertent release	03/04/2019
03/12/2018	114599	RBC411	PHL33	Goods van/truck/utility	Fail	5, 3	Green 2 action	Lighting	One required headlamp is not fitted, not securely attached or is not operational	03/04/2019

DL Number: s9(2)(a)

Driver: s9(2)(a)

Insp Date	CVIR Sheet #	QID	Plate	Vehicle Types Meaning	Insp Result	Insp Lvl	Fault Action	Fault Category	Fault desc	COF Expiry Date
16/08/2018	872864	RBC411	M829A	Trailer/caravan	Fail	3	Green 2 action	Lighting	One required rear reflector fitted, not securely fitted, colour other than red, anytime	03/10/2018
16/08/2018	872864	RBC411	PHL12	Goods van/truck/utility	Pass	3	No Action			24/10/2018



DL Number: s9(2)(a)

Driver: s9(2)(a)

Insp Date	CVIR Sheet #	QID	Plate	Vehicle Types Meaning	Insp Result	Insp Lvl	Fault Action	Fault Category	Fault desc	COF Expiry Date
16/04/2018	854940	RBC411	P352C	Trailer/caravan	Pass	3	No Action			20/09/2018
16/04/2018	854940	RBC411	PHL15	Goods van/truck/utility	Fail	3	Green 2 action	Load Anchorage	Bolster not securely fitted or attachment is damaged – no immediate risk of failure	01/09/2018

DL Number: s9(2)(a)

Driver: s9(2)(a)

Insp Date	CVIR Sheet #	QID	Plate	Vehicle Types Meaning	Insp Result	Insp Lvl	Fault Action	Fault Category	Fault desc	COF Expiry Date
08/09/2017	826958	RBC411	L402L	Trailer/caravan	Fail	3	Pink sticker	Lighting	All side marker lamps not operational (during darkness)	13/01/2018
08/09/2017	826958	RBC411	L402L	Trailer/caravan	Fail	3	Pink sticker	Lighting	A rear tail lamp is not operational (during darkness) no other rear right lamp operational	13/01/2018
08/09/2017	826958	RBC411	PHL11	Goods van/truck/utility	Pass	3	No Action			13/01/2018

DL Number: s9(2)(a)

Driver: s9(2)(a)

Insp Date	CVIR Sheet #	QID	Plate	Vehicle Types Meaning	Insp Result	Insp Lvl	Fault Action	Fault Category	Fault desc	COF Expiry Date
14/11/2018	117925	JBJ227	PHL23	Goods van/truck/utility	Pass	5, 3	No Action			21/05/2019
14/11/2018	117925	JBJ227	Q884L	Trailer/caravan	Fail	5, 3	Pink sticker	Suspension	Suspension component not fitted/not securely fitted	30/04/2019
14/11/2018	117925	JBJ227	Q884L	Trailer/caravan	Fail	5, 3	Green 2 action	Wheels and Tyres	Tyre not correctly inflated – operation/control not affected	30/04/2019

Released under the Official Information Act 1983

DL Number: s9(2)(a)

Driver: s9(2)(a)

Insp Date	CVIR Sheet #	QID	Plate	Vehicle Types Meaning	Insp Result	Insp Lvl	Fault Action	Fault Category	Fault desc	COF Expiry Date
17/05/2017	815297	BWD335	PHL35	Goods van/truck/utility	Fail	5, 3	Green 2 action	Brakes	Air leaks any other system	17/11/2017
17/05/2017	815297	BWD335	T672A	Trailer/caravan	Pass	5, 3	No Action			08/11/2017
15/06/2017	816149	RBC411	PHL35	Goods van/truck/utility	Fail	5, 3	Green 2 action	Lighting	One stop lamp is fitted, not working, excessively damaged or fully obscured. Single vehicle or rear unit of combo	17/11/2017
15/06/2017	816149	RBC411	PHL35	Goods van/truck/utility	Fail	5, 3	Green 2 action	Lighting	One required headlamp is not fitted, not securely attached or is not operational	17/11/2017
04/07/2017	816172	RBC411	PHL35	Goods van/truck/utility	Fail	3	Green 2 action	Lighting	Daytime running lamp works intermittently/operates with fog lights, not securely fitted or damaged	17/11/2017
04/07/2017	816172	RBC411	PHL35	Goods van/truck/utility	Fail	3	Green 2 action	Lighting	One required headlamp is not fitted, not securely attached or is not operational	17/11/2017
04/07/2017	816172	RBC411	T672A	Trailer/caravan	Pass	3	No Action			08/11/2017
05/09/2017	826949	RBC411	PHL35	Goods van/truck/utility	Pass	3	No Action			17/11/2017
05/09/2017	826949	RBC411	T672A	Trailer/caravan	Pass	3	No Action			08/11/2017

DL Number: s9(2)(a)

Driver: s9(2)(a)

Insp Date	CVIR Sheet #	QID	Plate	Vehicle Types Meaning	Insp Result	Insp Lvl	Fault Action	Fault Category	Fault desc	COF Expiry Date
22/07/2017	768999	ATY330	7P447	Trailer/caravan	Pass	5	No Action			12/01/2018
22/07/2017	768999	ATY330	PHL37	Goods van/truck/utility	Pass	5	No Action			20/01/2018

Released under the Official Information Act 1982

DL Number: s9(2)(a)

Driver: s9(2)(a)

Insp Date	CVIR Sheet #	QID	Plate	Vehicle Types Meaning	Insp Result	Insp Lvl	Fault Action	Fault Category	Fault desc	COF Expiry Date
03/10/2018	114451	RBC411	PHL30	Goods van/truck/utility	Pass	5, 3	No Action			04/03/2019
03/10/2018	114451	RBC411	R443P	Trailer/caravan	Fail	5, 3	Pink sticker	Load Anchorage	Sliding bolster – no locking mechanism	02/03/2019
19/12/2018	123569	RBC411	PHL30	Goods van/truck/utility	Fail	5, 3	Green 2 action	Fluid Leaks	Fluid leaks other	04/03/2019
19/12/2018	123569	RBC411	R443P	Trailer/caravan	Fail	5, 3	Pink sticker	Suspension	Suspension component not fitted/not securely fitted	02/03/2019
19/12/2018	123569	RBC411	R443P	Trailer/caravan	Fail	5, 3	Green 2 action	Wheels and Tyres	A tyre is damaged/imbedded object – operation not affected	02/03/2019

DL Number: s9(2)(a)

Driver: s9(2)(a)

Insp Date	CVIR Sheet #	QID	Plate	Vehicle Types Meaning	Insp Result	Insp Lvl	Fault Action	Fault Category	Fault desc	COF Expiry Date
04/10/2017	832115	GME708	7K728	Trailer/caravan	Pass	5, 3	No Action			21/12/2017
04/10/2017	832115	GME708	PHL38	Goods van/truck/utility	Pass	5, 3	No Action			22/11/2017
19/02/2019	126815	RBC411	7K728	Trailer/caravan	Pass	5, 3	No Action			07/06/2019
19/02/2019	126815	RBC411	PHL38	Goods van/truck/utility	Pass	5, 3	No Action			22/05/2019

DL Number: s9(2)(a)

Driver: s9(2)(a)

Insp Date	CVIR Sheet #	QID	Plate	Vehicle Types Meaning	Insp Result	Insp Lvl	Fault Action	Fault Category	Fault desc	COF Expiry Date
27/02/2018	854254	BWD335	PHL06	Goods van/truck/utility	Pass	5, 3	No Action			26/05/2018
27/02/2018	854254	BWD335	Z505Y	Trailer/caravan	Pass	5, 3	No Action			21/05/2018
08/11/2018	114485	RBC411	PHL06	Goods van/truck/utility	Pass	5, 3	No Action			26/11/2018
08/11/2018	114485	RBC411	Z505Y	Trailer/caravan	Pass	5, 3	No Action			21/11/2018

Released under the Official Information Act 1982

DL Number: s9(2)(a)

Driver: s9(2)(a)

Insp Date	CVIR Sheet #	QID	Plate	Vehicle Types Meaning	Insp Result	Insp Lvl	Fault Action	Fault Category	Fault desc	COF Expiry Date
01/11/2017	837227	RBC411	PHL36	Goods van/truck/utility	Fail	3	Green sticker	Lighting	Direction indicator lamp is damaged, fully obscured or output affected/failure imminent or is not securely fitted (detachment is imminent)	30/03/2018
18/01/2018	837646	BLDA87	6Y910	Trailer/caravan	Pass	5	No Action			18/01/2018
18/01/2018	837646	BLDA87	PHL36	Goods van/truck/utility	Pass	5	No Action			18/01/2018
13/11/2018	105599	BWD335	6Y910	Trailer/caravan	Fail	5, 3	Green 2 action	Brakes	Suzie coil hose does not comply, support spring missing/ineffective	19/03/2019
13/11/2018	105599	BWD335	PHL36	Goods van/truck/utility	Pass	5, 3	No Action			14/03/2019

DL Number: s9(2)(a)

Driver: s9(2)(a)

Insp Date	CVIR Sheet #	QID	Plate	Vehicle Types Meaning	Insp Result	Insp Lvl	Fault Action	Fault Category	Fault desc	COF Expiry Date
13/11/2018	117159	WHG676	PHL16	Goods van/truck/utility	Pass	5, 3	No Action			26/01/2019
13/11/2018	117159	WHG676	S25E	Trailer/caravan	Pass	5, 3	No Action			26/01/2019

DL Number: s9(2)(a)

Driver: s9(2)(a)

Insp Date	CVIR Sheet #	QID	Plate	Vehicle Types Meaning	Insp Result	Insp Lvl	Fault Action	Fault Category	Fault desc	COF Expiry Date
17/09/2018	872898	RBC411	PHL01	Goods van/truck/utility	Pass	5, 3	No Action			04/11/2018
17/09/2018	872898	RBC411	Z760L	Trailer/caravan	Fail	5, 3	Pink sticker	Lighting	No stop lamps fitted, no stop lamps working, are excessively damaged or fully obscured. Single vehicle or rear unit of combo	23/10/2018

DL Number: s9(2)(a)

Driver: s9(2)(a)

Insp Date	CVIR Sheet #	QID	Plate	Vehicle Types Meaning	Insp Result	Insp Lvl	Fault Action	Fault Category	Fault desc	COF Expiry Date
19/02/2019	126816	RBC411	PHL01	Goods van/truck/utility	Pass	5, 3	No Action			04/05/2019
19/02/2019	126816	RBC411	Z760L	Trailer/caravan	Pass	5, 3	No Action			23/04/2019

DL Number: s9(2)(a)

Driver: s9(2)(a)

Insp Date	CVIR Sheet #	QID	Plate	Vehicle Types Meaning	Insp Result	Insp Lvl	Fault Action	Fault Category	Fault desc	COF Expiry Date
15/06/2017	816151	RBC411	L402L	Trailer/caravan	Pass	5, 3	No Action			13/07/2017
15/06/2017	816151	RBC411	PHL11	Goods van/truck/utility	Fail	5, 3	Green 2 action	Load Anchorage	Bolster not securely fitted or attachment is damaged – no immediate risk of failure	13/07/2017
18/12/2018	107332	PNIQ51	8K642	Trailer/caravan	Pass	5, 3	No Action			29/05/2019
18/12/2018	107332	PNIQ51	PHL13	Goods van/truck/utility	Pass	5, 3	No Action			15/06/2019

DL Number: s9(2)(a)

Driver: s9(2)(a)

Insp Date	CVIR Sheet #	QID	Plate	Vehicle Types Meaning	Insp Result	Insp Lvl	Fault Action	Fault Category	Fault desc	COF Expiry Date
07/03/2017	805596	RBC411	M829A	Trailer/caravan	Fail	5, 3	Green 2 action	Lighting	One indicator light is not working on the rear of combination	24/04/2017
07/03/2017	805596	RBC411	PHL12	Goods van/truck/utility	Pass	5, 3	No Action			24/04/2017
04/10/2017	832209	GGI670	GDU506	Goods van/truck/utility	Pass	5, 3	No Action			05/12/2017
04/10/2017	832209	GGI670	S532N	Trailer/caravan	Pass	5, 3	No Action			20/12/2017

DL Number: s9(2)(a)

Driver: s9(2)(a)

Insp Date	CVIR Sheet #	QID	Plate	Vehicle Types Meaning	Insp Result	Insp Lvl	Fault Action	Fault Category	Fault desc	COF Expiry Date
20/06/2018	857359	RBC411	GDU506	Goods van/truck/utility	Fail	3	Green 2 action	Lighting	Daytime running lamp works intermittently/operates with fog lights, not securely fitted or damaged	06/12/2018
10/08/2018	867925	RBC411	GDU506	Goods van/truck/utility	Fail	3	Green 2 action	Lighting	Daytime running lamp works intermittently/operates with fog lights, not securely fitted or damaged	06/12/2018
20/02/2019	126823	RBC411	PHL06	Goods van/truck/utility	Fail	5, 3	Green 2 action	Lighting	Side marker lamp not operational, not secure, damaged or obscured	26/05/2019
20/02/2019	126823	RBC411	Z505Y	Trailer/caravan	Pass	5, 3	No Action			21/05/2019

DL Number: s9(2)(a)

Driver: s9(2)(a)

Insp Date	CVIR Sheet #	QID	Plate	Vehicle Types Meaning	Insp Result	Insp Lvl	Fault Action	Fault Category	Fault desc	COF Expiry Date
03/04/2018	854929	RBC411	PHL26	Goods van/truck/utility	Pass	3	No Action			01/08/2018
13/11/2018	117057	BWD335	9Z511	Trailer/caravan	Pass	5, 3	No Action			13/01/2019
13/11/2018	117057	BWD335	PHL42	Goods van/truck/utility	Pass	5, 3	No Action			13/01/2019

DL Number: s9(2)(a)

Driver: s9(2)(a)

Insp Date	CVIR Sheet #	QID	Plate	Vehicle Types Meaning	Insp Result	Insp Lvl	Fault Action	Fault Category	Fault desc	COF Expiry Date
05/12/2017	839683	RBC411	PHL04	Goods van/truck/utility	Pass	3	No Action			02/05/2018

DL Number: s9(2)(a)

Driver: s9(2)(a)

Insp Date	CVIR Sheet #	QID	Plate	Vehicle Types Meaning	Insp Result	Insp Lvl	Fault Action	Fault Category	Fault desc	COF Expiry Date
11/01/2018	841627	BWD335	PHL16	Goods van/truck/utility	Fail	5, 3	Green sticker	Mudguards	One mudguard missing/does not comply or a mudflap not fitted to a twin tyred axle	26/07/2018
11/01/2018	841627	BWD335	PHL16	Goods van/truck/utility	Fail	5, 3	Pink sticker	Wheels and Tyres	A tyre is damaged – operation affected and/or failure imminent	26/07/2018
11/01/2018	841627	BWD335	S25E	Trailer/caravan	Pass	5, 3	No Action			26/07/2018

DL Number: s9(2)(a)

Driver: s9(2)(a)

Insp Date	CVIR Sheet #	QID	Plate	Vehicle Types Meaning	Insp Result	Insp Lvl	Fault Action	Fault Category	Fault desc	COF Expiry Date
25/06/2018	861241	RBC411	PHL12	Goods van/truck/utility	Fail	3	Green 2 action	Lighting	One direction Indicator lamp not working	24/10/2018
25/06/2018	861241	RBC411	PHL12	Goods van/truck/utility	Fail	3	Green 2 action	Lighting	One or more front park lamps not operational (anytime)	24/10/2018

DL Number: s9(2)(a)

Driver: s9(2)(a)

Insp Date	CVIR Sheet #	QID	Plate	Vehicle Types Meaning	Insp Result	Insp Lvl	Fault Action	Fault Category	Fault desc	COF Expiry Date
03/10/2017	828698	GME708	J880M	Trailer/caravan	Pass	5, 3	No Action			22/12/2017

Insp Date	CVIR Sheet #	QID	Plate	Vehicle Types Meaning	Insp Result	Insp Lvl	Fault Action	Fault Category	Fault desc	COF Expiry Date
03/10/2017	828698	GME708	PHL29	Goods van/truck/utility	Pass	5, 3	No Action			21/12/2017
14/11/2017	814676	BLDA87	K438A	Trailer/caravan	Fail	5	Pink sticker	Lighting	No stop lamps fitted, no stop lamps working, are excessively damaged or fully obscured. Single vehicle or rear unit of combo	17/05/2018
14/11/2017	814676	BLDA87	PHL04	Goods van/truck/utility	Pass	5	No Action			02/05/2018
13/04/2018	850703	BLDA87	PHL02	Goods van/truck/utility	Fail	5	Green 2 action	Wheels and Tyres	1 wheel nut loose/missing, 1 stud damaged/missing	07/10/2018
13/04/2018	850703	BLDA87	R177T	Trailer/caravan	Pass	5	No Action			07/10/2018
26/04/2018	857314	RBC411	PHL02	Goods van/truck/utility	Pass	3	No Action			07/10/2018
26/04/2018	857314	RBC411	R177T	Trailer/caravan	Fail	3	Green 2 action	Lighting	One required rear reflector fitted, not securely fitted, colour other than red, anytime	07/10/2018
25/06/2018	861240	RBC411	PHL02	Goods van/truck/utility	Fail	3	Green sticker	Lighting	Direction indicator lamp is damaged, fully obscured or output affected/failure imminent or is not securely fitted (detachment is imminent)	07/10/2018
10/08/2018	867923	RBC411	PHL02	Goods van/truck/utility	Pass	2	No Action			07/10/2018
10/08/2018	867923	RBC411	R177T	Trailer/caravan	Fail	2	Pink sticker	Load Anchorage	Sliding bolster – no locking mechanism	07/10/2018
10/08/2018	867923	RBC411	R177T	Trailer/caravan	Fail	2	Green 2 action	Lighting	One direction Indicator lamp not working	07/10/2018
15/11/2018	121783	WDJ177	PHL02	Goods van/truck/utility	Pass	5, 3	No Action			08/04/2019
15/11/2018	121783	WDJ177	R177T	Trailer/caravan	Fail	5, 3	Pink sticker	Wheels and Tyres	Side wall unzipping	08/04/2019
21/02/2019	126829	RBC411	PHL02	Goods van/truck/utility	Pass	5, 3	No Action			08/04/2019
21/02/2019	126829	RBC411	R177T	Trailer/caravan	Fail	5, 3	Pink sticker	Lighting	No stop lamps fitted, no stop lamps working, are excessively damaged or fully obscured. Single vehicle or rear unit of combo	08/04/2019
21/02/2019	126829	RBC411	R177T	Trailer/caravan	Fail	5, 3	Pink sticker	Lighting	Whole indicator system does not operate	08/04/2019
21/02/2019	126829	RBC411	R177T	Trailer/caravan	Fail	5, 3	Green 2 action	Lighting	Side marker lamp not operational, not secure, damaged or obscured	08/04/2019
21/02/2019	126829	RBC411	R177T	Trailer/caravan	Fail	5, 3	Green 2 action	Lighting	A rear tail lamp is not operating, damaged or fully obscured	08/04/2019

DL Number: s9(2)(a)

Driver: s9(2)(a)

Insp Date	CVIR Sheet #	QID	Plate	Vehicle Types Meaning	Insp Result	Insp Lvl	Fault Action	Fault Category	Fault desc	COF Expiry Date
17/07/2018	861276	RBC411	PHL07	Goods van/truck/utility	Fail	3	Green 2 action	Lighting	Stop lamp emits colour other than red, or is obscured	16/12/2018

DL Number: s9(2)(a)

Driver: s9(2)(a)

Insp Date	CVIR Sheet #	QID	Plate	Vehicle Types Meaning	Insp Result	Insp Lvl	Fault Action	Fault Category	Fault desc	COF Expiry Date
14/03/2017	805609	RBC411	5W717	Trailer/caravan	Pass	3	No Action			22/05/2017
14/03/2017	805609	RBC411	PHL27	Goods van/truck/utility	Pass	3	No Action			19/04/2017
03/10/2017	833895	PJAT18	5W717	Trailer/caravan	Pass	5, 3	No Action			31/10/2017
03/10/2017	833895	PJAT18	PHL27	Goods van/truck/utility	Pass	5, 3	No Action			19/10/2017
02/11/2017	837235	RBC411	5W717	Trailer/caravan	Fail	3	Pink sticker	Lighting	No stop lamps fitted, no stop lamps working, are excessively damaged or fully obscured. Single vehicle or rear unit of combo	30/04/2018
02/11/2017	837235	RBC411	PHL27	Goods van/truck/utility	Fail	3	Green sticker	Lighting	One or more than two daytime running lamps fitted	19/04/2018
02/11/2017	837235	RBC411	PHL27	Goods van/truck/utility	Fail	3	Green 2 action	Lighting	A headlamp is damaged failure is imminent or light output on either side is not approx equal	19/04/2018
20/06/2018	857358	RBC411	PHL27	Goods van/truck/utility	Fail	3	Pink sticker	Lighting	No stop lamps fitted, no stop lamps working, are excessively damaged or fully obscured. Single vehicle or rear unit of combo	19/10/2018
15/11/2018	117175	WHG676	5W717	Trailer/caravan	Fail	5, 3	Green sticker	Brakes	Stroke of brake chamber exceeds manufacturer's limit - service brake performance doesn't meet legal requirements	30/04/2019
15/11/2018	117175	WHG676	PHL27	Goods van/truck/utility	Pass	5, 3	No Action			19/04/2019

Released under the Official Information Act 1982



DL Number: s9(2)(a)

Driver: s9(2)(a)

Insp Date	CVIR Sheet #	QID	Plate	Vehicle Types Meaning	Insp Result	Insp Lvl	Fault Action	Fault Category	Fault desc	COF Expiry Date
14/11/2018	114553	RBC411	PHL20	Goods van/truck/utility	Fail	5, 3	Green sticker	Brakes	Spring brake/electric brake control for parking brakes not protected from inadvertent release	07/03/2019
14/11/2018	114553	RBC411	PHL20	Goods van/truck/utility	Fail	5, 3	Green sticker	Suspension	Shock absorber missing, damaged or leaking excessively (wet or dripping)	07/03/2019
14/11/2018	114553	RBC411	T674A	Trailer/caravan	Fail	5, 3	Pink sticker	Brakes	Air leak low air pressure <30 seconds	07/03/2019
14/11/2018	114553	RBC411	T674A	Trailer/caravan	Fail	5, 3	Green 2 action	Load Anchorage	Bolster not securely fitted or attachment is damaged – no immediate risk of failure	07/03/2019
12/12/2018	107318	PNIQ51	PHL20	Goods van/truck/utility	Pass	5, 3	No Action			07/03/2019
12/12/2018	107318	PNIQ51	T674A	Trailer/caravan	Fail	5, 3	Pink sticker	Suspension	Air bag damaged/fully deflated – laden	07/03/2019

DL Number: s9(2)(a)

Driver: s9(2)(a)

Insp Date	CVIR Sheet #	QID	Plate	Vehicle Types Meaning	Insp Result	Insp Lvl	Fault Action	Fault Category	Fault desc	COF Expiry Date
04/10/2017	832205	GGI670	PHL20	Goods van/truck/utility	Pass	5, 3	No Action			06/03/2018
04/10/2017	832205	GGI670	T674A	Trailer/caravan	Pass	5, 3	No Action			07/03/2018
14/11/2018	114556	RBC411	6F838	Trailer/caravan	Fail	5, 3	Green 2 action	Brakes	Suzie coil hose does not comply, support spring missing/ineffective	18/01/2019
14/11/2018	114556	RBC411	6F838	Trailer/caravan	Fail	5, 3	Pink sticker	Brakes	ABS/EBS system is not operating - Combination vehicle	18/01/2019
14/11/2018	114556	RBC411	6F838	Trailer/caravan	Fail	5, 3	Green 2 action	Lighting	One required rear reflector fitted, not securely fitted, colour other than red, anytime	18/01/2019
14/11/2018	114556	RBC411	6F838	Trailer/caravan	Fail	5, 3	Green 2 action	Ball-race Turntables	Ball-race turntable fasteners loose (other)	18/01/2019
14/11/2018	114556	RBC411	PHL28	Goods van/truck/utility	Fail	5, 3	Green 2 action	Lighting	Daytime running lamp works intermittently/operates with fog lights, not securely fitted or damaged	18/01/2019
14/11/2018	114556	RBC411	PHL28	Goods van/truck/utility	Fail	5, 3	Green 2 action	Lighting	One required headlamp is not fitted, not securely attached or is not operational	18/01/2019

DL Number: s9(2)(a)

Driver: s9(2)(a)

Insp Date	CVIR Sheet #	QID	Plate	Vehicle Types Meaning	Insp Result	Insp Lvl	Fault Action	Fault Category	Fault desc	COF Expiry Date
05/10/2017	836073	PJAT18	PHL22	Goods van/truck/utility	Fail	5, 3	Pink sticker	Brakes	Park brake actuator missing/not operational/does not lock into position, remains applied when released, is not securely fastened & may detach. Risk of inadvertent release	26/01/2018
05/10/2017	836073	PJAT18	R462K	Trailer/caravan	Pass	5, 3	No Action			26/01/2018
25/06/2018	861239	RBC411	PHL20	Goods van/truck/utility	Fail	3	Green 2 action	Lighting	A fog lamp is insecure, damaged or out of alignment	07/09/2018
25/06/2018	861239	RBC411	PHL20	Goods van/truck/utility	Fail	3	Green 2 action	Lighting	One direction Indicator lamp not working	07/09/2018
25/06/2018	861239	RBC411	PHL20	Goods van/truck/utility	Fail	3	Green 2 action	Lighting	One required rear reflector fitted, not securely fitted, colour other than red, anytime	07/09/2018
17/08/2018	872868	RBC411	9Z516	Trailer/caravan	Pass	3	No Action			24/01/2019
17/08/2018	872868	RBC411	PHL43	Goods van/truck/utility	Pass	3	No Action			24/01/2019
15/11/2018	117941	JB227	9Z516	Trailer/caravan	Pass	5, 3	No Action			24/01/2019
15/11/2018	117941	JB227	PHL43	Goods van/truck/utility	Pass	5, 3	No Action			24/01/2019

Total Vehicles Inspected:	188	Fault Action	Tota	Vehicle Action	Total
Total Faults:	112	Pink sticker	29	Compliance	9
Total Fails:	82	Green sticker	22	No Action	105
Total Passes:	106	Green 2 action	61	Ordered to comply/Green 2	2
Total Fault Actions:	112	No Action	106	Pink	1
Avg No Faults per Vehicle:	0.60		218	Roadside Remedy	20
Avg No. Faults per Failed Vehicle:	1.37			Verbal Direction	51
					188

### Summary of Passes and Fails

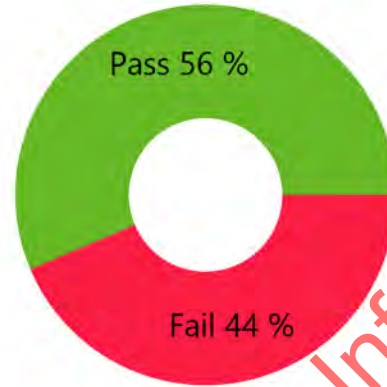

Total Fails:	82
% of Vehicles Failed:	43.6%
Total Passes:	106
% of Vehicles Passed:	56.4%
No. Faults Found:	112

### Frequency of Faults



Fault Category	# Faults	% of Vehicles
Brakes	24	21%
Cab, Chassis and Body	1	1%
Exhaust System	3	3%
Exterior	8	7%
Lighting	52	46%
Motive	3	3%
PSV Wheels and Tyres	1	1%
Suspension	8	7%
Towing & 5th Wheel	2	2%
Wheels, Tyres & Mudguards	10	9%
<b>Total</b>	<b>112</b>	<b>100%</b>

### Fails By Month

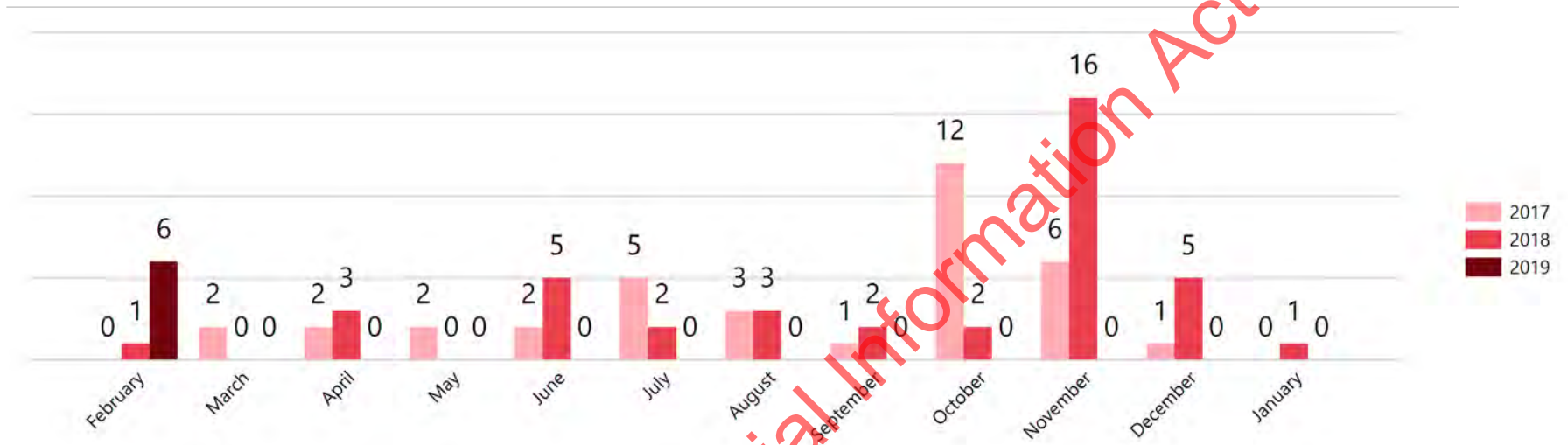

### Passes By Month

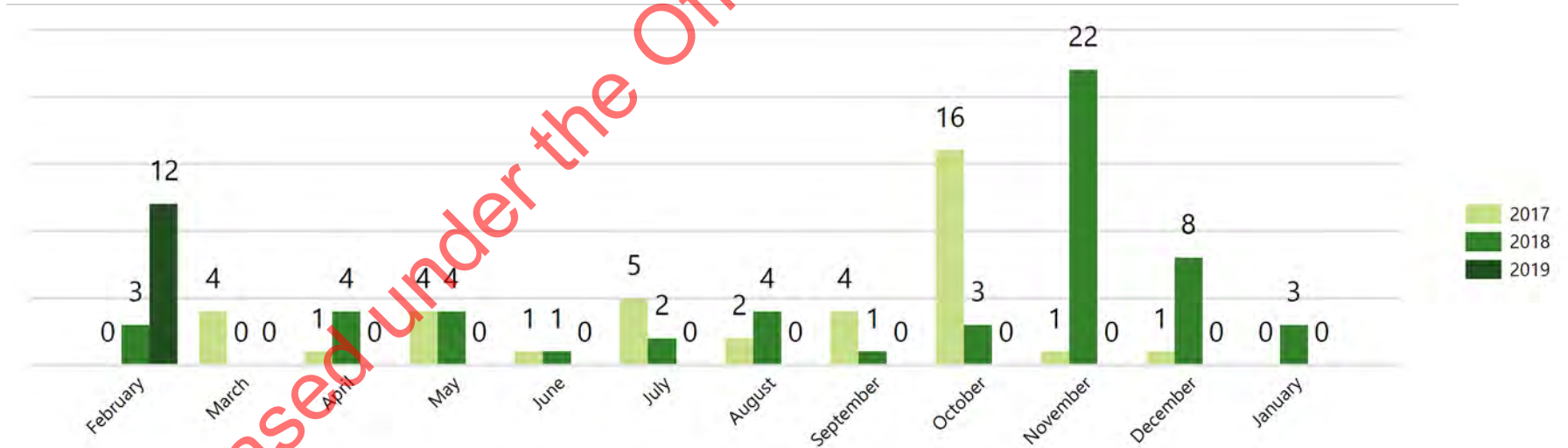

### Pass / Fail Per Inspection Level by Vehicle

Level	Fail	Pass	Total
2	1	1	2
3	23	20	43
5	4	11	15
5, 3	52	74	126
6, 3	2	0	2
<b>Total</b>	<b>82</b>	<b>106</b>	<b>188</b>

### Number of Faults Per Inspection Level

Highest Level	No of Faults
2	2
3	32
5	4
5, 3	71
6, 3	3
<b>Total</b>	<b>112</b>

### Fault Action by Inspection Level

Level	Fault Action	Fail	Pass
2	Green 2 action	1	0
	No Action	0	1
	Pink sticker	1	0
3	Green 2 action	21	0
	Green sticker	5	0
	No Action	0	20
	Pink sticker	6	0
	Green 2 action	3	0
5	No Action	0	11
	Pink sticker	1	0
	Green 2 action	33	0
5, 3	Green sticker	17	0
	No Action	0	74
	Pink sticker	21	0
6, 3	Green 2 action	3	0
	<b>Total</b>	<b>112</b>	<b>106</b>

Released under the Official Information Act 1983

### Inspection Notes

Date/Time	Plate	Vehicle Details	Inspection Notes
7/03/17 4:45 PM	M829A PHL12	2008 KENWORTH T 2008 KRAFT 404	Additional Notes Log Book Page: RTF 432703-29  DEFECT INFORMATION FAULT 1: Indicator to operate.
14/03/17 9:56 AM	5W717 PHL27	2016 KENWORTH T 2016 KRAFT 400	Additional Notes Log Book Page: RTFNZ 20324-1
15/03/17 11:21 AM	PHL06 Z505Y	2014 KENWORTH T 2014 KRAFT 404	DEFECT INFORMATION FAULT 1: Top shock bolt loose.  Additional Notes Log Book Page: Rtfnz2034333.
3/04/17 11:15 AM	PHL15	2009 KENWORTH T	Log Book Page: RTFNZ 20345-40.
11/04/17 9:22 AM	PHL01 Z760L	2014 KENWORTH T 2014 KRAFT 404	Log Book Page: Rtfnz-1
16/05/17 2:31 PM	PHL34 Y951K	2014 KENWORTH T 2014 KRAFT 404	Log Book Page: Rtfnz2032037
17/05/17 2:52 PM	PHL35 T672A	2012 KRAFT 400 2014 KENWORTH T	Log Book Page: Rtfnz2030728
31/05/17 10:53 AM	7B837 PHL25	2017 KENWORTH T 2017 KRAFT 400	Log Book Page: Rtf45943012
15/06/17 7:41 AM	PHL35	2014 KENWORTH T	Log Book Page: RTFNZ 20307-46
15/06/17 12:15 PM	402L PHL11	2008 KENWORTH T 2008 KRAFT 404	Log Book Page: RTFNZ 20349-47
4/07/17 12:31 PM	PHL35 T672A	2012 KRAFT 400 2014 KENWORTH T	Log Book Page: RTF 459409-8
5/07/17 10:33 AM	PHL08 U789M	2013 KRAFT 404 2016 KENWORTH T	Log Book Page: RTFNZ 20321-33
6/07/17 7:00 AM	PHL32 W198L	2013 KENWORTH T 2013 KRAFT 404	Log Book Page: Rtf45941513

Released under the Official Information Act 1982

17/07/17 6:50 AM	H469A PHL07	2006 EVANS 4AC 2009 KENWORTH T	Log Book Page: RTFNZ002979-17
22/07/17 11:18 AM	7P447 PHL37	2017 KENWORTH T 2017 KRAFT 400	Log Book Page: Rtfn220322-6
1/08/17 1:49 PM	H469A PHL07	2006 EVANS 4AC 2009 KENWORTH T	Log Book Page: RTFNZ 002979-27
11/08/17 8:05 AM	PHL13	2001 KENWORTH K104	Log Book Page: RTF 459426-50.
22/08/17 4:24 PM	K898F PHL05	2007 KENWORTH T 2007 KRAFT 400	Log Book Page: PHL 0061-7
5/09/17 12:25 PM	PHL35 T672A	2012 KRAFT 400 2014 KENWORTH T	Log Book Page: RTF 459409-50
8/09/17 5:59 AM	L402L PHL11	2008 KENWORTH T 2008 KRAFT 404	Log Book Page: PHL 0084-7
11/09/17 6:36 AM	PHL01	2014 KENWORTH T	Log Book Page: PHL 0099-7
3/10/17 10:12 AM	PHL23 Q884L	2010 KENWORTH T408 2010 KRAFT 404	Log Book Page: Phl026
3/10/17 10:22 AM	J880M PHL29	2001 EVANS 4AS 2010 KENWORTH K108	Log Book Page: PHL 0052-5
3/10/17 12:15 PM	M829A PHL12	2008 KENWORTH T 2008 KRAFT 404	Log Book Page: Phl 0069-28 Driver notes: Driver advised of repair to be completed and given pink sticker.
3/10/17 2:18 PM	7B837 PHL25	2017 KENWORTH T 2017 KRAFT 400	Log Book Page: PHL 0058-38
3/10/17 2:52 PM	5W717 PHL27	2016 KENWORTH T 2016 KRAFT 400	Log Book Page: PHL 0072-20
4/10/17 7:24 AM	J880M PHL29	2001 EVANS 4AS 2010 KENWORTH K108	Log Book Page: Phl091 Driver notes: Compliance ticket for tyre.
4/10/17 8:32 AM	PHL20 T674A	2012 KENWORTH K108 2012 KRAFT 404	Log Book Page: Phl090
4/10/17 11:06 AM	GDJ506 S532N	2011 KENWORTH T 2011 KRAFT 404	Log Book Page: Phl074
4/10/17 1:14 PM	7K728 PHL38	2017 KENWORTH T 2017 KRAFT 400	Log Book Page: PHL0089-34
4/10/17 3:36 PM	K239N PHL10	2007 KENWORTH T 2007 KRAFT 404	Log Book Page: PHL 0078-28
5/10/17 8:30 AM	PHL35 T672A	2012 KRAFT 400 2014 KENWORTH T	Log Book Page: Phl 0022-2

5/10/17 2:48 PM	PHL22 R462K	2011 KENWORTH K 2011 KRAFT 404	Log Book Page: Nza 6567-04 Driver notes: Ion with compliance for company.
11/10/17 7:38 AM	H469A PHL07	2006 EVANS 4AC 2009 KENWORTH T	Log Book Page: PHL 0064-49
19/10/17 10:53 AM	K438A PHL04	2007 KENWORTH K104 2007 KRAFT 404	Log Book Page: PHL 0032-27
1/11/17 6:11 AM	PHL36	2017 KENWORTH T	Log Book Page: PHL 0083-47
2/11/17 11:00 AM	5W717 PHL27	2016 KENWORTH T 2016 KRAFT 400	Log Book Page: PHL 0072-42
14/11/17 10:02 AM	K438A PHL04	2007 KENWORTH K104 2007 KRAFT 404	Log Book Page: 0052-26
30/11/17 1:58 PM	K239N PHL10	2007 KENWORTH T 2007 KRAFT 404	Log Book Page: PHL 0053-14
5/12/17 2:57 AM	PHL10	2007 KENWORTH T	Log Book Page: PHL 0053-18
5/12/17 3:32 AM	PHL04	2007 KENWORTH K104	Log Book Page: PHL 0019-39
11/01/18 2:18 PM	PHL16 S25E	2011 KENWORTH K108 2011 KRAFT 404	Log Book Page: Phl004549
18/01/18 12:10 PM	6Y910 PHL36	2017 KENWORTH T 2017 KRAFT 400	Log Book Page: PHL 0034-39
8/02/18 10:31 AM	PHL31 W970G	2013 KENWORTH T 2013 KRAFT 404	Log Book Page: PHL 008-6 Driver notes: Windscreen damaged LHS.
27/02/18 6:53 AM	PHL06 Z505Y	2014 KENWORTH T 2014 KRAFT 404	Log Book Page: Phl01158
3/04/18 1:39 PM	PHL26	2016 KENWORTH T	Log Book Page: PHL 0118-21
13/04/18 7:03 AM	PHL02 R177T	2011 KENWORTH K108 2011 KRAFT 404	
16/04/18 7:04 AM	P352C PHL15	2009 KENWORTH T 2009 KRAFT 404	Log Book Page: PHL 0112-42 Driver notes: I-Bright RUC machine to be able to be viewed by enforcement officer out side of truck (either door).
26/04/18 7:42 AM	PHL02 R177T	2011 KENWORTH K108 2011 KRAFT 404	Log Book Page: PHL 0191-15
3/05/18 7:38 AM	PHL18	2010 KENWORTH T	ADDITIONAL NOTES: 508482,

Released under the Official Information Act 1982



11/05/18 7:13 AM	PHL29 U789M	2010 KENWORTH K108 2013 KRAFT 404	Log Book Page: PHL 0124-46
17/05/18 11:50 AM	PHL23	2010 KENWORTH T408	Log Book Page: PHL 0171-6 Driver notes: LHS mirror marker lamps to operate.
20/06/18 6:05 AM	PHL32	2013 KENWORTH T	Log Book Page: PHL 0199-41
20/06/18 8:29 AM	PHL27	2016 KENWORTH T	Log Book Page: PHL 000266-34
20/06/18 9:48 AM	GDU506	2011 KENWORTH T	Log Book Page: PHL0215-17
25/06/18 2:35 PM	PHL20	2012 KENWORTH K108	Log Book Page: PHL 0166-21
25/06/18 3:08 PM	PHL02	2011 KENWORTH K108	Log Book Page: PHL0191-49
25/06/18 3:32 PM	PHL12	2008 KENWORTH T	Log Book Page: PHL 0160-2
7/07/18 6:40 AM	7P447 PHL37	2017 KENWORTH T 2017 KRAFT 400	Log Book Page: PHL 000270-42
13/07/18 10:47 AM	PHL37	2017 KENWORTH T	Log Book Page: PHL 000270-47
17/07/18 12:02 PM	PHL07	2009 KENWORTH T	Log Book Page: PHL 0136-4
10/08/18 7:00 AM	PHL02 R177T	2011 KENWORTH K108 2011 KRAFT 404	Log Book Page: PHL 0153-23
10/08/18 12:04 PM	GDU506	2011 KENWORTH T	Log Book Page: PHL 000210-01
16/08/18 10:08 AM	M829A PHL12	2008 KENWORTH T 2008 KRAFT 404	Log Book Page: PHL 0150-28
17/08/18 7:17 AM	9Z516 PHL43	2018 KENWORTH T 2018 KRAFT 505	Log Book Page: PHL 000219-09
17/09/18 2:10 PM	PHL01 Z760L	2014 KENWORTH T 2014 KRAFT 404	Log Book Page: PHL 000225-15
27/09/18 11:57 AM	PHL05	2007 KENWORTH T	Log Book Page: PHL 000228-24
3/10/18 7:28 AM	PHL30 R443P	2011 KENWORTH K 2011 KRAFT 404	Log Book Page: PHL 000207-23 Driver notes: Washers to operate
26/10/18 1:22 PM	K898F PHL05	2007 KENWORTH T 2007 KRAFT 400	Log Book Page: Phl00022843

30/10/18 2:41 AM	[REDACTED]	PHL12	2008 KENWORTH T	Log Book Page: Phl000284 18 Driver notes: Trailer lights not operating
8/11/18 1:52 PM	[REDACTED]	PHL06 Z505Y	2014 KENWORTH T 2014 KRAFT 404	Log Book Page: PHL 000277-31
12/11/18 12:03 PM	[REDACTED]	PHL32 W198L	2013 KENWORTH T 2013 KRAFT 404	Log Book Page: PHL 000223-38
13/11/18 5:44 AM	[REDACTED]	9Z511 PHL42	2018 KENWORTH T 2018 KRAFT 505	Log Book Page: Phl00028233
13/11/18 7:10 AM	[REDACTED]	PHL16 S25E	2011 KENWORTH K108 2011 KRAFT 404	Log Book Page: Phl224-31 0430 gisborne
13/11/18 8:45 AM	[REDACTED]	PHL35 T672A	2012 KRAFT 400 2014 KENWORTH T	Log Book Page: PHL 000231-14
13/11/18 8:48 AM	[REDACTED]	6Y910 PHL36	2017 KENWORTH T 2017 KRAFT 400	Log Book Page: Phl00028737 Driver notes: Made a visit to [REDACTED] and spoke to [REDACTED] the workshop manager. I Explained the requirements for a full trailer operating with suzi coils as per Heavy brake rule.
13/11/18 1:26 PM	[REDACTED]	K898F PHL05	2007 KENWORTH T 2007 KRAFT 400	Log Book Page: PHL 000238-0
14/11/18 7:40 AM	[REDACTED]	PHL23 Q884L	2010 KENWORTH T408 2010 KRAFT 404	Log Book Page: PHL 000243-09 Driver notes: Verbal Warning given bolster pins not in 2nd bolster
14/11/18 8:18 AM	[REDACTED]	PHL20 T674A	2012 KENWORTH K108 2012 KRAFT 404	Log Book Page: PHL 000237-13
14/11/18 9:41 AM	[REDACTED]	6F838 PHL28	2017 KENWORTH T 2017 KRAFT 400	Log Book Page: PHL276-33
14/11/18 11:06 AM	[REDACTED]	PHL18 R179F	2010 KENWORTH T 2011 KRAFT 404	Log Book Page: PHL 000295-14
14/11/18 11:46 AM	[REDACTED]	N102T PHL14	2009 KENWORTH K108 2009 KRAFT 404	Log Book Page: PHL 000234-22
15/11/18 7:13 AM	[REDACTED]	4Z305 PHL26	2016 KENWORTH T 2016 KRAFT 404	Log Book Page: Phl236-05 0400 gisborne
15/11/18 8:43 AM	[REDACTED]	5W717 PHL27	2016 KENWORTH T 2016 KRAFT 400	Log Book Page: Phl280-38 0000 awapuni road
15/11/18 10:58 AM	[REDACTED]	PHL34 Y951K	2014 KENWORTH T 2014 KRAFT 404	Log Book Page: PHL 0229-43
15/11/18 1:26 PM	[REDACTED]	9Z506 PHL41	2018 KENWORTH T 2018 KRAFT 507	Log Book Page: PHL 000297-22 Gisborne 0400

15/11/18 1:48 PM	[REDACTED]	PHL02 R177T	2011 KENWORTH K108 2011 KRAFT 404	Log Book Page: PHL 000279-39 Gisborne 0500 Driver notes: Chip in windscreen in upper part of drivers CVA. Windscreen to be replaced within 14 days. 3rd axle LHS outer tyre un zipping. Photos taken. Bar between 1st and 2nd axle under transmission cracked RHS. Driver informed of faults.
15/11/18 1:52 PM	[REDACTED]	9Z516 PHL43	2018 KENWORTH T 2018 KRAFT 505	Log Book Page: PHL 000232-24
26/11/18 5:59 AM	[REDACTED]	4Z305 PHL26	2016 KENWORTH T 2016 KRAFT 404	Log Book Page: PHL 000236-13
3/12/18 6:09 AM	[REDACTED]	PHL33	2013 KENWORTH T	Log Book Page: PHL 0294-33
3/12/18 10:46 AM	[REDACTED]	PHL09 Z745L	2014 KENWORTH T 2014 KRAFT 404	Log Book Page: PHL 0281-43
12/12/18 6:46 AM	[REDACTED]	4Z305 PHL26	2016 KENWORTH T 2016 KRAFT 404	Log Book Page: PHL 0236-26
12/12/18 7:31 AM	[REDACTED]	PHL20 T674A	2012 KENWORTH K108 2012 KRAFT 404	Log Book Page: 000237-33
13/12/18 10:20 AM	[REDACTED]	7B837 PHL25	2017 KENWORTH T 2017 KRAFT 400	Log Book Page: PHL 000260-02
18/12/18 3:07 PM	[REDACTED]	8K642 PHL13	2017 KENWORTH T 2017 KRAFT 404	Log Book Page: Phl 000247-26
19/12/18 7:48 AM	[REDACTED]	PHL30 R443P	2011 KENWORTH K 2011 KRAFT 404	Log Book Page: PHL 000253-10
5/02/19 3:26 PM	[REDACTED]	K898F PHL05	2007 KENWORTH T 2007 KRAFT 400	Log Book Page: PHL 000323-02
8/02/19 10:32 AM	[REDACTED]	P352C PHL15	2009 KENWORTH T 2009 KRAFT 404	Log Book Page: PHL 000318-09
14/02/19 3:28 PM	[REDACTED]	7P447 PHL37	2017 KENWORTH T 2017 KRAFT 400	Log Book Page: PHL 000264-37
19/02/19 6:27 AM	[REDACTED]	7K728 PHL38	2017 KENWORTH T 2017 KRAFT 400	Log Book Page: PHL 000254-38
19/02/19 7:27 AM	[REDACTED]	PHL01 Z760L	2014 KENWORTH T 2014 KRAFT 404	Log Book Page: PHL 000303-30
20/02/19 6:51 AM	[REDACTED]	PHL06 Z505Y	2014 KENWORTH T 2014 KRAFT 404	Log Book Page: PHL 000240-49
21/02/19 5:54 AM	[REDACTED]	PHL35 T672A	2012 KRAFT 400 2014 KENWORTH T	Log Book Page: PHL 000315-21

s9(2)(a)

21/02/19 6:27 AM	PHL02 R177T	2011 KENWORTH K108 2011 KRAFT 404	Log Book Page: PHL 00026-46
27/02/19 5:56 AM	4Z305 PHL26	2016 KENWORTH T 2016 KRAFT 404	Log Book Page: PHL 000317-21

Released under the Official Information Act 1982

Pacific Haulage Limited

107 Aerodrome Road

Matawhero

GISBORNE

To 

**Notice of Audit**

Section 198 Land Transport Act 1998 (PART A)

**PART A**

Pursuant to section 198 of the Land Transport Act 1998, the NZ Transport Agency (the Agency) may, in writing, require any person who holds a land transport document that authorises the provision of a service in the land transport system to undergo such inspections and audits as the Agency reasonably considers necessary in the interests of land transport safety.

The Agency may require any information that it reasonably considers to be relevant to the inspection or audit.

A person who is required by the Agency to provide information under section 198 must comply with that requirement, and there is a related offence in section 51 of the Land Transport Act 1998 for failing or refusing (without reasonable excuse) to comply with a requirement in relation to an audit or inspection.

Relevant sections of the Land Transport Act 1998 are attached at **Appendix 1** for your information.

You are hereby advised of the Agency's intention to conduct an audit of the vehicles and records in respect of the transport services provided under the Transport Service Licence (TSL) number  issued in the name Pacific Haulage Limited.

In order to facilitate the audit, **you are required to provide the following information:**

1. Copies of current employment and/or contractual agreements for the following drivers:

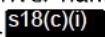

These are to be provided regardless of whether the driver is or is not currently employed by or contracted to Pacific Haulage Limited.

2. A GPS Overspeed summary report for the calendar month of February 2019 for all vehicles, showing overspeed events by "Number of Events by Vehicle" and "Number of Events by Speed Band", and showing both the driver name and vehicle identification, for all vehicles operated by Pacific Haulage Limited, TSL 

Released under the Official Information Act 1982

3. Detailed GPS Overspeed reports for the following six vehicles, showing the time, date, location and speed for all individual overspeed occurrences for the calendar month of February 2019.
  - PHL02
  - PHL13
  - PHL26
  - PHL34
  - PHL39
  - PHL40
4. All documentation and correspondence related to the identification and reporting of all overspeed related incidents for those six vehicles listed above for the calendar month of February 2019. This is to include all correspondence between the company and drivers showing where action has been taken to address overspeed incidents, and any remedial action taken where required.
5. All documentation relating to traffic offending, work time and/or logbook breaches for all drivers for the 3 month period from 10<sup>th</sup> December 2019 to 10<sup>th</sup> March 2019 inclusive.
6. All documentation relating to drug testing of all drivers for the 12 month period ending Sunday 10<sup>th</sup> of March 2019, including but not limited to requests for testing, results for testing and employment action taken as a result of test results. This is to include all testing for pre-employment purposes whether the subject was or was not subsequently employed by Pacific Haulage Limited.
7. All or any documentation, whether written or electronically recorded by drivers for the purpose of daily vehicle pre-deployment checks for all vehicles operated by Pacific Haulage Limited, TSL s18(c)(i) for a one month period from Monday 11<sup>th</sup> February 2019 to Sunday 10<sup>th</sup> of March 2019 inclusive.
8. All vehicle maintenance records for vehicles operated by Pacific Haulage Limited, TSL s18(c)(i) including but not limited to fault sheets, job sheets or cards, service and maintenance records, check sheets and reports from Monday 11<sup>th</sup> February 2019 to Sunday 10<sup>th</sup> of March 2019 inclusive. Invoices provided by s9(2)(b)(ii) previously submitted are to be excluded.

All items must be sent to the Agency either in person or by courier to NZTA, Level 2, 50 Victoria Street, Wellington, Attention Nathan Murrell or electronically via email to nathan.murrell@nzta.govt.nz by 5pm on Monday the 1<sup>st</sup> of July 2019.

Please be advised that failing or refusing to comply with any requirements of sections 30ZD or 30ZH is an offence under sections 79N and 79Q of the Land Transport Act 1998.

Yours Sincerely

s9(2)(a)

Nathan Murrell

Commercial Transport Officer

## Appendix 1

### LAND TRANSPORT ACT 1998

#### **198 Inspections and audits**

- (1) The Agency may in writing require any person who holds a land transport document that authorises the provision of a service in the land transport system to undergo such inspections and audits as the Agency reasonably considers necessary in the interests of land transport safety (including inspections and audits of vehicles operated by such persons).
- (2) The Agency may carry out such inspections and audits as the Agency reasonably considers necessary in the interests of land transport safety.
- (3) For the purposes of any inspection or audit carried out in respect of any person under this section, the Agency may in writing require that person to provide such information as the Agency reasonably considers relevant to the inspection or audit.
- (4) A person to whom a requirement is made under this section must comply with that requirement.

#### **51 Contravention of section 198(4)**

- (1) A person commits an offence if the person, without reasonable excuse, fails or refuses to comply with a requirement made under section 198 in relation to an audit or inspection.
- (2) The maximum penalty on conviction for an offence against subsection (1) is a fine not exceeding \$5,000.

#### **30A Requirements for vehicles**

- (1) A holder of a transport service licence must ensure that—
  - (a) every vehicle to be used in the service is maintained in a fit and proper condition and that the requirements of any Act, regulation, or rule made for this purpose are met;
  - (b) no vehicle is used in the service unless and until all fees payable in respect of the vehicle and the service under any Act, regulation, or bylaw have been duly paid or appropriate arrangements have been made for payment.
- (2) The holder of any transport service licence must, whenever required to do so by the Agency, present for inspection any transport service vehicle used in the service.
- (2A) The driver of a small passenger service vehicle must, whenever required to do so by the Agency, present the vehicle for inspection.
- (3) No evidence of vehicle inspection may be issued in respect of a transport service vehicle unless the person issuing the evidence of vehicle inspection has been notified of the transport service licence number under which the vehicle is being operated.
- (4) No person may use a transport service vehicle if that vehicle has suffered serious damage until the vehicle has been inspected and passed as being safe by a person authorised by the Agency, or the owner of the vehicle has been informed by such a person that the vehicle is not to be inspected.
- (5) Nothing in subsection (1), (3), or (4) applies to a vehicle used in a small passenger service.
- (6) Nothing in this section applies to—
  - (a) the facilitator of a facilitated cost-sharing arrangement; or
  - (b) a vehicle used in a facilitated cost-sharing arrangement; or
  - (c) a vehicle designed or adapted to carry 12 or fewer persons (including the driver) provided by one of the passengers being carried.

#### **30ZD Records must be kept**

- (1AA) Subsection (1) applies to—
  - (a) a person who employs a person to drive a vehicle referred to in section 30ZB; and
  - (b) a self-employed driver who drives a vehicle referred to in section 30ZB; and
  - (c) a facilitator who facilitates a driver who drives a vehicle referred to in section 30ZB to connect with passengers.

- (1) A person to whom this section applies must keep all—
  - (a) time records, records of payments to the driver, and employment or contractual records relating to the driver; and
  - (b) accommodation records and receipts for the driver that are relevant to the driver's transport service or transport service vehicle; and
  - (c) fuel records and receipts for the relevant transport service vehicles.
- (2) The person who keeps the records required under subsection (1) must—
  - (a) keep each record for 12 months from the date it is made; and
  - (b) make all relevant records referred to in subsection (1) in the possession or control of that person available for immediate inspection on demand at any reasonable time by an enforcement officer.
- (3) Every enforcement officer to whom records are made available for inspection under subsection (2)(b) is entitled to make copies of those records.

#### **79N Failure to keep or produce records or comply with conditions of exemption or approval**

Every person commits an offence who fails or refuses to comply with any of the requirements of section 30ZD or the conditions of any exemption granted or approval given under section 30ZA(1)(a) or (c), and is liable on conviction,—

- (a) in the case of a driver, to a fine not exceeding \$2,000, and the person may, for a period of 1 calendar month or such greater period as the court thinks fit, be disqualified from holding or obtaining a licence to drive any vehicle that—
  - (i) requires a class 2, 3, 4, or 5 licence (as specified in the rules); or
  - (ii) is used in the relevant transport service; or
  - (iii) is used to carry goods for hire or reward; or
- (b) in any other case, to a fine not exceeding \$100,000.

#### **30ZH Duties regarding logbooks**

- (1) A driver must—
  - (a) retain a logbook required to be maintained by that driver under section 30ZF for a period of 12 months after the date of the last entry in that logbook; and
  - (b) in the case of a driver who is an employee, or who is driving on behalf of a transport service operator, or who is facilitated to connect with passengers by a small passenger service operator, deliver a copy of each completed logbook record to the driver's employer or transport service operator within 14 days after completing that record, and the employer or transport service operator must retain the copy of each logbook record for a period of 12 months from the date of the record.
- (1A) Despite anything in subsection (1), if the logbook only contains entries for a light RUC vehicle (as defined in section 5(1) of the Road User Charges Act 2012), the driver must retain the logbook only for a period of 12 months.
- (2) A driver must—
  - (a) carry a logbook with him or her at all times when driving a vehicle to which section 30ZE applies; and
  - (b) produce, on demand by any enforcement officer and without delay, any logbook that—
    - (i) the driver is required to maintain; and
    - (ii) relates to—
      - (A) the day of the driver's last rest time of at least 24 hours; and
      - (B) all the days since that rest time.
- (3) If the form of the logbook required to be maintained under section 30ZF includes an identical copy made simultaneously with the original of that logbook, and the logbook has been produced to an enforcement officer, that enforcement officer is entitled, on demand,—
  - (a) to remove that identical copy; or
  - (b) if that identical copy has previously been removed or is illegible, to make a copy of that logbook.
- (4) A person who is required to retain a logbook or a copy of a logbook under subsection (1) must make it and all relevant time records, records of payments to the driver, and employment or contractual records relating to the driver available for immediate inspection on demand by an



enforcement officer at any reasonable time during the period for which it is required to be retained.

- (5) A person to whom a logbook or a copy of a logbook or records are required to be made available for inspection under subsection (4) is entitled to make a copy of that logbook or that copy or those records.

**79Q Failure to discharge duties regarding logbooks**

Every person who fails or refuses to comply with any requirement of or demand made under section 30ZH commits an offence and is liable on conviction,—

- (a) in the case of a driver, to a fine not exceeding \$2,000, and the person may, for a period of 1 calendar month or any greater period that the court thinks fit, be disqualified from holding or obtaining a licence to drive any vehicle that—
- (i) requires a class 2, 3, 4, or 5 licence (as specified in the rules); or
  - (ii) is used in the relevant transport service; or
  - (iii) is—
    - (A) a heavy motor vehicle; and
    - (B) used to carry goods for hire or reward:
- (b) in any other case, to a fine not exceeding \$25,000.

**113A Power to inspect records**

- (1) For the purpose of ascertaining whether this Act has been or is being complied with by any person to whom this Act applies, any enforcement officer in uniform or in possession of a warrant or other evidence of his or her authority as an enforcement officer may require that person to produce without delay for inspection all relevant books or records in that person's possession or over which that person has control, including (but not limited to) records kept under section 65 of the Road User Charges Act 2012, logbooks, records associated with logbooks, financial records relating to expenditure on fuel, invoices, vehicle maintenance records, depreciation records for vehicles, time and wage records, and waybills.
- (2) The enforcement officer may take extracts from or make copies of any books or records so produced.

Released under the Official Information Act 1982



**To** Rob Montgomery  
Commercial Transport Advisor

**From** Nathan Murrell  
Commercial Transport Officer

**Date** 17<sup>th</sup> May 2019

**Subject** Pacific Haulage Limited  
TSL: s18(c)(i)  
Pseudo: s18(c)(i)

---

## BACKGROUND

Pacific Haulage Limited is a Gisborne based goods transport licence operator based in Gisborne. Their primary business is the transportation of logs from forestry sites to Gisborne Port and local processing plants. They operate a modern fleet of approximately 40 truck and trailer units with similar staff numbers. A small portion of the fleet is operated to contracted owner/operators.

In 2018 company s9(2)(a) The company is now under the management of two directors, Calvin John Paddon and Warwick Kenneth Wilshier. Paddon is a 50% shareholder of the business, while the other 50% is held by Wilshier Management Limited of which Wilshier is the sole director.

s9(2)(ba)(i)

A desktop analysis was undertaken for Pacific Haulage Limited in early February 2019. The company showed a 94% pass rate at COF inspections for the last two-year period, approximately 60% of which were related to brake issues. However, the pass rates for roadside (RID) inspections has fallen to 56%, which is well below the national average at the time of 82.9%.

When the RID and COF rates are compared they show an imbalance of nearly 40%. This would indicate on face value that there is an inadequate system of daily pre-deployment vehicle checks being undertaken, or that no system is in place at all.

On the 12<sup>th</sup> of March 2019 the agency issued Pacific Haulage Limited a "Notice of Audit" under s198 of the Land Transport Act 1998 to produce records for the purpose of an analysis of the company's operations.

On Wednesday the 27<sup>th</sup> of March 2019, along with Ben Gamboni, I attended a meeting at Pacific Haulage Limited in Gisborne, primarily for the collection of the above records. The meeting was held at the request of s9(2)(a) who was present with s9(2)(a) and other company management.

s9(2)(a) was wanting to question the reasoning behind the agency undertaking the audit of his company. I was direct in telling him about the concerns of CVST staff, and that a desktop audit had shown a very low RID inspection pass rate. In reply, Wilshier was dismissive of the RID inspections, saying that CVST staff were being "nit-picky" with faults, and putting too much emphasis on lighting and other "minor issues".

## ANALYSIS OF RECORDS

Analysis of the records produced by Pacific Haulage Limited has been completed as of Friday the 17<sup>th</sup> of May 2019. The initial analysis looks at the submitted records and follows the points as outlined in the s198 request as follows:

1. A complete list of the vehicle fleet was provided, including all tractor unit registrations, corresponding fleet numbers and trailer registrations as a combination.
2. A list of all drivers was provided but did not meet the requirements of the s198 request. The first and last names, along with driver's licence number were provided, however no home address details or contact phone numbers were listed. A cross check of the TORO system, which the company uses, showed this list to be mostly complete.
3. No information has been provided in relation to drivers traffic offending, work time and/or logbook breaches, nor drug testing of drivers. Included in the submission in reply to point 7, is a copy of an accident investigation dated 12<sup>th</sup> February 2019. The incident report notes under the heading "Action Taken", s9(2)(a) *taken for post incident drug test (copy attached)*". There is no copy of the drug test attached to the incident report, nor submitted under this request.
4. All driver logbooks were submitted for the period requested. No other records were submitted regarding employment or contractual agreements, time records, running sheets, accommodation or other related receipts.
5. Although comprehensive fuel receipts were supplied in this instance, due to the nature of the business being localised haulage, this is not a focus of this audit.
6. Four comprehensive folders were supplied with GPS reports taken from each vehicles E-Road unit. The folders were indexed by vehicle registration and all reports placed in chronological order. Some of the data has been removed identifying why some of the events were recorded i.e. overspeed events, however the remaining data was useful for analysis of logbook records.
7. Only a single incident report was submitted for a vehicle crash that had occurred on the 12<sup>th</sup> of February 2019.

8. Two folders were presented, broken down into registration order with invoices in chronological order. Very few contained any fault sheets, and there were no corresponding maintenance records or daily vehicle check sheets.

In summary, the company has failed to meet the demands of the s198 request, submitting insufficient records or no records at all for some of the items requested.

#### **DRIVER LOGBOOKS AND GPS RECORDS**

Analysis of the driver logbooks was done with cross reference to the GPS records. The initial focus was placed on those drivers who were regularly being paid 70 hours per week, being the maximum hours a driver can work in a cumulative work week under the "Work Time and Logbooks Rule 2007".

From the sample that was analysed, most drivers had omissions, false entries and rest break breaches. The reasons for these varied but examples are:

- Break times recorded in logbooks showing a full 30-minute break, but GPS records show the vehicle moving inside this break time.
- Recording start and end times in logbooks to comply with 10-hour break rules, but GPS records show the vehicle moving outside of these times.
- Incorrectly recording locations where breaks have been taken i.e. recorded as "Gisborne" when the vehicle GPS records show the vehicle in Tolaga Bay.

In a lot of instances, the driver's logbook entries constitute false entries. Recording of breaks when GPS records show that a vehicle was only stopped for 20 minutes, means that a break has not actually legally been taken, and leads to a breach of the "5.5-hour rule". Some drivers are therefore driving between 10 and 14 hours without taking a legal break.

Daily end and start times have been entered to show compliance with the "10-hour break rule", when GPS records clearly show that the rule has been breached. There was also one instance of a driver recording a 15-hour work day.

It appears clear that there is no system in place for the company to scrutinise driver logbooks for errors, omissions and false entries. These should have been addressed with the drivers responsible and remedial training given in logbook requirements. Ongoing breaches should be dealt with by way of a disciplinary processes.

This would also indicate that the company is not fulfilling its obligations in managing driver fatigue correctly, as many of the drivers are failing to comply with compulsory rest breaks. This poses a serious risk to the roading network and the safety of all users.

## VEHICLE CRASH & INCIDENT REPORTS

Only a single vehicle accident report was submitted, for an incident that occurred on the 12<sup>th</sup> of February 2019, involving the rollover of a trailer following separation of a brake line.

Although the report appears to be well presented, I found its contents, investigations, conclusions and recommendations are very poorly undertaken and lacking any real conclusion as to how or why the incident occurred. None of the accompanying material as mentioned in the report was submitted i.e. copies of the drug testing and results, and the actual reason for the brake line separating was not identified.

Incidents such as this one have happened on private roads, so are not attended by Police. However, the potential for serious harm or a fatality on public roads if this scenario was to occur is very real, and these incidents should be treated seriously and correctly investigated and reported. It is imperative therefore that the actual cause of incidents such as this are identified, not just the symptoms.

## DAILY VEHICLE INSPECTIONS

No documentation was provided to show that drivers are undertaking daily vehicle pre-deployment inspections at the beginning of their work day. Although verbal reassurance was given that checks are undertaken, without written or recorded evidence of this occurring we can only conclude that pre-deployment checks are not performed.

This finding is backed up by the fact that RID inspections for the two-year period to date are showing a very low 56% pass rate. This compares poorly to the national average of 82.9%

Most of the RID inspection faults relate to lighting faults (47%), brakes (22%) and wheels and tyres (9%). These three items are fundamental to the safe operation of any vehicle, even more so for heavy vehicles operating under heavy vehicle permits conditions or driving on roads such as those found in this area.

## MAINTENANCE

The workshop operates on the same premises, but is operated as a separate business, TPW Workshop Limited. Although the records have been submitted in a very neat and tidy manner, all that has been submitted are copies of invoices from the workshop, a very small selection of vehicle fault sheets completed by some drivers and some vehicles have service cards attached.

Verbal discussions with management and workshop staff on the 27<sup>th</sup> of March 2019 established that each vehicle is bought in for a weekly grease. Set intervals by KM's driven are used for the servicing of brakes.

In analysis of the invoices by Vehicle Specialist Neil McAlpine, there appears to be absolutely no system or integration between the operation of the vehicles or maintenance in the workshop.

Records show mostly reactive maintenance repairs, such as replacing lights, damaged fixtures and fittings like chains and securing points, trailer plugs and sockets, and leaking shock and brake components as examples. There is no clear pattern to suggest that a proactive maintenance programme is in place.

The workshop service cards that are attached to some of the records don't match up in any way to any of the invoices by date. Some invoices list "Safety Check" as one of the items, but there is nothing attached to describe what checks were undertaken on that date, or who was responsible for those checks.

There does not appear to be a robust end to end system in place to ensure vehicle faults are checked for daily pre-deployment, recorded and reported, and appropriate action taken and also clearly recorded. If this system was in place it would dramatically decrease the number of faults that are being found at roadside inspections, increasing the RID pass rate.

## RECOMMENDATION

It has become evident through the analysis of the supplied information, that Pacific Haulage Limited have failed to provide a large portion of the information requested.

Areas of concern are the total lack of employee contracts, no drug testing records and the manipulation of E-road data by removing some information. This would lead me to believe that there are aspects of the business that the company do not want to disclose, and non-disclosure is an attempt to hide information. If this is the case, then the company have done so at their own detriment.

With consideration to s9(2)(a) the position that this company is in currently with regards to its poor RID pass rates shows a lack of "practicing what they preach."

Excerpts from the LTSC website include the following:

- "A log truck-trailer combination typically travels over 100,000km per year often in harsh conditions. Maintaining a log truck under these conditions means that it should be checked daily by the driver..."
- "The operator should establish, implement and maintain documented procedures for undertaking daily roadworthiness checks and have processes in place for rectify the faults that are identified."
- "Any faults should to be recorded and systems should be in-place that ensures faults are repaired before they adversely affect the performance of the vehicle and its safety."
- "The transport operator has a responsibility to ensure appropriate training is provided for all of the people involved. This includes drivers, managers and maintenance personnel."

This audit has found that there can be no formal systems in place for daily driver vehicle checks to be performed, and if there are, then there is a serious lack of recording and system coherency. Since absolutely no information in regards to these checks has been supplied for audit, then we can only assume that this is the case.

It is my recommendation that Pacific Haulage Limited be served with a "Notice of Proposal to Revoke", with consideration to implementing some or all of the following points:

- A daily vehicle pre-deployment check system be implemented for all fleet vehicles/drivers.
- A plan showing how identified faults are to be triaged and reported for repair to the workshop.
- A programme is in place to review and monitor the pre-deployment checks system and address any issues identified with drivers. This includes remedial training if required.
- Provide proof to the agency that there is a full, proper and proactive maintenance programme in place, with accurate recording of maintenance.
- A monitoring system is implemented for driver logbooks to identify non-compliance with the "Work Time and Logbook Rule 2007", with a clear written plan showing how drivers are held to account for errors and a record of training provided.
- All drivers to undergo a remedial "Drivers Logbook Course" to ensure that they are all brought up to an acceptable standard with consideration to implementing the daily vehicle checks.
- The agency is to review all incident reports for the last two year period, in order to assist in developing a more thorough investigation protocol around serious incidents.

I also recommend that all vehicles that have failed RID inspections over the last 2 years be placed on 3-month COF inspections until such point the RID pass rates improve to the satisfaction of the agency. This is to be implemented at the same time that the Notice of Proposal is put in place, as an immediate measure to reduce the risk of a serious harm incident due to poor vehicle conditions.

s9(2)(a)



Nathan Murrell  
Commercial Transport Officer

Released under the Official Information Act 1982



## Vehicle Specialist Report Operator Vehicle Maintenance Records Assessment for PACIFIC HAULAGE LIMITED

TSL number:	s18(c)(i)
Operator's name:	PACIFIC HAULAGE LIMITED
Operator type:	GOODS SERVICE
Industry/vehicle type:	LOG HAULAGE.
Vehicle Specialist:	NEIL McALPINE

Vehicle Data	Current Results Date: 28/02/2019 COF and 1/03/2019 RID
COF Pass rate:	94%
COF Faults Per Failed Vehicle (FPFV):	1.26
COF Average faults on all inspections:	0.07
Total number of COF inspections:	340
Total number of COF passes:	321
Total number of COF fails:	19
Total number of COF faults:	24
Total number of vehicles inspected:	97
Average age of Fleet	6.66 years
RID pass rate:	56%
Total of RID passes	103
Total of RID fails	81
Total number of RID faults:	111
RID Faults Per Failed Vehicle (FPFV):	1.37037
RID Average faults on all inspections:	0.60326
Total number of RID inspections:	103
Total number of vehicles inspected: (some more than once)	184

Released under the Official Information Act 1982



The below COF percentages are out of 100% for each category

Main COF Faults as percentage of failed inspections:	% of all faults and number of faults per-category
Air Systems	5% / 1
Brakes	68% / 13
Chassis	11% / 2
Exterior	11% / 2
Lighting	11% / 2
Suspension	16% / 3
Towing	5% / 1
Main Roadside faults as percentage of failed inspections:	% of all faults and number of faults
Air Systems	9% / 10
Brakes	22% / 24
Exterior	7% / 8
Lighting	47% / 52
Motive	6% / 6
Suspension	6% / 7
Towing	2% / 2
Vehicle	2% / 2
	100% / 111

The COF and Roadside Inspection Databases records show that this operator's COF pass rate of (95%) is above the national average pass rate of 84% and the Roadside pass rate of (56%) is lower than the national RID pass rate of 84%.

The below average roadside pass rate indicates a problem either the drivers not doing walkaround inspection on these failed vehicles or the workshop isn't addressing faults identified to them, it's most likely a driver issue when looking at the number of lighting faults at 52.

#### Maintenance Document Review:

A review of the service records supplied, were checked to ensure that the servicing, maintenance and repairs undertaken in-house is being done in a regular proactive manner and in-line with the requirements of the Land Transport Act 1998 section 30A (1), and Land Transport Rule: Vehicle Repair 1998.

A review of the records shows that while the invoices have brief notes about repairs or a safety check being done, there was one (1) workshop document to show a service but nothing to confirm what repairs were done, this would show sign off on faults found. The records should include service or check sheets, or any forms used by the workshop staff to say what servicing is done and what items are included in the service, or what has been repaired.

When looking through the first combination (Truck and Trailer) PHL01 – Z760L, there are a lot of invoices dating from the 31<sup>st</sup> December 2018 to 11<sup>th</sup> March 2019. These are a tax invoices with very brief notes e.g. carry out safety check, grease vehicle. There is one invoice for each vehicle, an example is Tax Invoice 226115-1 for PHL01, this invoice notes the service date, speedo and hubometer readings, one and a half hours labour with carry out safety check, grease vehicle. The trailer invoice 226130-1

has service date, no hubometer reading, carry out service check and replace bolster chain, one and a half hours labour, and not much else. Neither vehicle has a check sheet to indicate what items were checked as part of any service. While some documents provided have the hubometer readings noted, it isn't the norm from what can be seen. Two more documents were supplied and titled Vehicle Fault Sheet, these appear to be filled out by the driver to address faults they identify. I believe there would be more than two (2) of these documents for a 3-month period.

The documents provided are not the documents that should have been given to allow the audit to be undertaken, the documents that need to be retained and supplied on request are the workaround check sheets done by the driver and any service sheets used either by the in-house mechanics or outside service providers. These are the documents that show what has accurately happen during a service or repair in the workshop not the tax invoice. As a service provider, the workshop undertaking repairs on vehicles should be using a service or job sheet which the mechanics fill out and this should be scanned or photocopied and supplied to the customer with the tax invoice for their records.

After going through the documents provided it's become clear that the data on the invoices don't include speedo or hubo readings all the time and even when they are entered there are typo's where the hubometer readings change, some by 300,000kms. This makes it very difficult to ensure that servicing is be done within a set distance. The dates appear mostly weekly with a grease and a safety check once a month. Due to the inaccurate tax invoice information, it's difficult to sure what servicing is carried out and what is covered during the service.

Due to the information supplied it's not worth the time to go through each tax invoice for each truck and trailer to try to work out and correct typos to build a photo of what is actually done and at what distance. The service dates are included on the tax invoices which is helpful to see time frames for servicing, but with inconsistent speedo and hubometer readings, as well as not all the information appearing to be on the tax invoices, makes it very difficult to follow and check.

With a roadside pass rate of 56% and 111 faults being found on 81 vehicles, this is a disappointing result for an operator that has a large fleet and operates their own workshop, there is room to improve system that are currently in place and this would include working with the drivers and workshop staff to improve the roadside inspection outcomes.

The Land Transport Act 1998 section 30A (1) requires vehicles to be maintained to act, regulations and rule (see below).

### **30A Requirements for vehicles**

(1) A holder of a transport service licence must ensure that—  
(a) every vehicle to be used in the service is maintained in a fit and proper condition and that the requirements of any Act, regulation, or rule made for this purpose, are met:

Land Transport Rule: Vehicle Repair 1998, requires that vehicles are maintained

2.1(1) A repair to a vehicle, its structure, systems, components or equipment, must restore the damaged or worn vehicle, structure, system, component or equipment so that they are within safe tolerance of the state of the vehicle, structure, system, component or equipment when manufactured.

2.1(2) If the vehicle has been certified as a modified vehicle, the repair must restore the vehicle, structure, system, component or equipment so that the vehicle is within safe tolerance of its state when certified as a modified vehicle.

Anything less than 100% pass rates for both COF and Roadside inspections shows that Pacific Haulage Limited aren't complying with the above acts and rules.

In the first instance, I recommend monitoring the vehicles via COF and Roadside inspections three monthly over the next twelve months, this is to check the operator's compliance levels. The vehicles that are currently failing roadside inspections should be put on 3-month COF inspections to assist with ensuring that they are compliant at all times.

NZTA can assist Pacific Haulage Limited by supplying a roadside inspection report to assist the workshop and fleet manager address the current low roadside pass rate. This report will also assist with addressing the drivers that may not carry out a walkaround check and items that the workshop may be not picking up as part of their current service programme.

If things don't improve a fleet audit should be done to identify what the compliance level of the fleet is. The results of any audit (if carried out) can assessed at that time to gauge the operation compliance level.

s9(2)(a)



Neil McAlpine  
Vehicle Specialist  
Wellington

17<sup>th</sup> May 2019

Released under the Official Information Act 1982

**Details**

**Date:** Wednesday 27 February 2019      **Time:** 05:56      **Police QID/NZTA ID:** RBC411, PNIQ51  
**Location:** Awapuni Road, Awapuni  
**Direction:** E      **Area:** 3      **GPS:** -38.66881627593065, 178.0007574243266  
**Inspection Level:** 3, 5, Wgt

**Driver**

**DLICNO:** s9(2)(a)      **DOB:** s9(2)(a)  
**Name:** s9(2)(a)      **Class:** 6, 4, 3, 5, 1, 2  
**Address:** s9(2)(a)      **Endorsed:** F, R, T, W  
**Ph:**      **Cell:** s9(2)(a)

**Operator**

**TSL:** s18(c)(i)      **Fleet #:** 26      **Ph:**      **Cell:**  
**Name:** PACIFIC HAULAGE LIMITED  
**Address:**  
**Contracted To:**

**Vehicle(s)**

**Over Dimension Permit:** No  
**Loaded:** Yes - Logs

	(A)	(B)	(C)	(D)
<b>Reg#:</b>	PHL26	4Z305		
<b>Vehicle Type:</b>	Truck	Full Trailer		
<b>Make/Model:</b>	Kenworth	Kraft		
<b>COF Expiry:</b>	26/07/2019	26/07/2019		
<b>L/Label Expiry:</b>	02/08/2019	11/08/2019		
<b>GVM:</b>				
<b>GCM:</b>				
<b>Tare:</b>				
<b>Axle Rating Front:</b>				
<b>Axle Rating Rear:</b>				
<b>ODO:</b>	177981 KM			
<b>Defects Found:</b>		Yes		
<b>Action Taken:</b>		Verbal Direction		
<b>RuL#:</b>	596146808	595829425		
<b>Type:</b>	H94	951		
<b>Wgt:</b>	50			
<b>Max Distance:</b>	241000	129000		
<b>Distance Recorder:</b>	239522	128367		
<b>Hub Make:</b>	Ibright	Data Trac Pro		
<b>Hub Serial:</b>	51/1625270136	12/10817		
<b>Tyre Size:</b>				
<b>Hubo Size:</b>				
<b>Additional RUC:</b>				
<b>RuL#:</b>				
<b>Type:</b>				
<b>Wgt:</b>				
<b>Max Distance:</b>				

**Defects**

B	4Z305	SS61 - Shock absorber missing, damaged or leaking excessively (wet or dripping) 1 x Axle LH shocker Leaking	Left Front	Green Sticker
---	-------	--	------------	---------------

**Weight**

**Overweight Permit:** Yes - 50MAX- HPMV-18-19327

	L	R	Total	Spacing	Permit
(A)	S				
	S		8860	1.9	
	T			6.09	
	T		16630	7.41	
	<b>Vehicle Gross Weight</b>		25490		0
(B)	T			12.51	
	T			13.76	
	T			17.59	
	T			18.85	
	T		25280	20.1	
	<b>Vehicle Gross Weight</b>		25280		0
	<b>Gross Weight</b>		50770		

**Axle Groups**

Group	Axles	Total Weight	Spacing
-------	-------	--------------	---------

**Additional Notes**

**Log Book Page:** PHL 000317-21

**Driver Notes:**

**Contact Details**

NZ Police Commercial Vehicle Safety Team

CVST Ohakea  
PO Box 1  
Sanson 4862  
Ph 06 329 3594  
Fax 06 329 3562  
Email cvst3@police.govt.nz

FOR: PACIFIC HAULAGE LIMITED

TSL Licence Number: [REDACTED]

Report Run dates between 28/02/2017 and 27/02/2019

			Air Systems	Brakes	Chassis	Exterior	Interior	Lighting	Motive	Steering	Towing	Suspension	Vehicle	Tyres	Other
13Q38	07/01/19	PASS													
4Z305	02/08/17	PASS													
	04/01/18	PASS													
	01/08/18	PASS													
5W717	28/12/18	PASS													
	03/04/17	PASS													
	09/10/17	PASS													
6F838	16/04/18	PASS													
	15/10/18	PASS													
	21/07/17	PASS													
6Y910	20/12/17	PASS													
	04/07/18	PASS													
	17/12/18	PASS													
7B837	25/09/17	PASS													
	19/03/18	PASS													
	12/09/18	PASS													
7K728	16/10/17	PASS													
	27/04/18	PASS													
	29/10/18	PASS													
7P447	22/11/17	PASS													
	09/05/18	PASS													
	19/11/18	PASS													
7U983	08/12/17	PASS													
	27/06/18	PASS													
	03/12/18	PASS													
7U983	05/03/18	PASS													
	24/09/18	PASS													

Released under the Official Information Act 1982

FOR: PACIFIC HAULAGE LIMITED

TSL Licence Number:

§18(c)(i)

Report Run dates between 28/02/2017 and 27/02/2019

			Air Systems	Brakes	Chassis	Exterior	Interior	Lighting	Motive	Steering	Towing	Suspension	Vehicle	Tyres	Other
8A839	12/03/18	PASS													
	10/09/18	PASS													
8K642	21/05/18	PASS													
	26/11/18	PASS													
9C103	25/07/18	PASS													
	04/01/19	PASS													
9Z506	12/11/18	PASS													
9Z511	12/12/18	PASS													
9Z516	03/01/19	PASS													
AYC954	29/03/17	PASS													
	29/09/17	PASS													
	29/03/18	PASS													
	21/09/18	FAIL		1											
GDU506	29/05/17	PASS													
	04/12/17	PASS													
	06/06/18	PASS													
	05/12/18	PASS													
H469A	31/05/17	PASS													
	29/11/17	PASS													
	30/05/18	PASS													
	21/11/18	PASS													
J169L	15/08/17	PASS													
	05/02/19	PASS													
J765S	25/03/17	PASS													
	29/09/17	PASS													
	28/04/18	PASS													
	25/10/18	PASS													
J816F	21/06/17	PASS													

Released under the Official Information Act 1982

FOR: PACIFIC HAULAGE LIMITED

TSL Licence Number: s18(c)(i)

Report Run dates between 28/02/2017 and 27/02/2019

		Air Systems	Brakes	Chassis	Exterior	Interior	Lighting	Motive	Steering	Towing	Suspension	Vehicle	Tyres	Other
	20/11/17	PASS												
	28/05/18	PASS												
	28/11/18	PASS												
J880M	14/06/17	FAIL			1						1			
	11/12/17	PASS												
	10/10/18	PASS												
K239N	29/03/17	PASS												
	27/09/17	PASS												
	29/12/17	PASS												
	21/01/19	PASS												
K436A	03/05/17	PASS												
	06/11/17	PASS												
	18/04/18	PASS												
	05/11/18	PASS												
K438A	01/05/17	PASS												
	01/11/17	PASS												
	13/03/18	PASS												
	18/10/18	PASS												
K898F	10/04/17	PASS												
	04/10/17	PASS												
	11/04/18	PASS												
	10/10/18	PASS												
KWB512	26/07/17	PASS												
	12/09/17	PASS												
KYG607	21/06/17	FAIL												
	15/08/17	PASS												
L402L	05/07/17	PASS												
	27/12/17	PASS												

Released under the Official Information Act 1982



FOR: PACIFIC HAULAGE LIMITED

TSL Licence Number: s18(c)(i)

Report Run dates between 28/02/2017 and 27/02/2019

		Air Systems	Brakes	Chassis	Exterior	Interior	Lighting	Motive	Steering	Towing	Suspension	Vehicle	Tyres	Other
	14/06/18	PASS												
	11/01/19	PASS												
LCL769	29/03/17	PASS												
	27/09/17	PASS												
	29/12/17	PASS												
	02/07/18	FAIL	1											
	09/01/19	PASS												
LGC224	01/05/17	PASS												
	01/11/17	PASS												
	13/03/18	PASS												
	17/10/18	PASS												
LHM253	03/05/17	PASS												
	06/11/17	FAIL									1			
	18/04/18	PASS												
	05/11/18	PASS												
LMF809	05/07/17	PASS												
	27/12/17	PASS												
	14/06/18	PASS												
	16/01/19	PASS												
LUM43	19/04/17	PASS												
	18/10/17	PASS												
	28/03/18	PASS												
	03/10/18	PASS												
M675K	26/07/17	PASS												
	12/09/17	PASS												
	18/04/18	FAIL	1											
	06/11/18	FAIL							2					
M829A	19/04/17	PASS												

Released under the Official Information Act 1982

FOR: PACIFIC HAULAGE LIMITED

TSL Licence Number: s18(c)(i)

Report Run dates between 28/02/2017 and 27/02/2019

		Air Systems	Brakes	Chassis	Exterior	Interior	Lighting	Motive	Steering	Towing	Suspension	Vehicle	Tyres	Other
	03/10/17	PASS												
	28/03/18	PASS												
N102T	03/10/18	PASS												
	17/05/17	PASS												
	15/11/17	PASS												
	23/05/18	PASS												
P352C	30/10/18	PASS												
	23/08/17	PASS												
	21/02/18	PASS												
	22/08/18	PASS												
	13/02/19	PASS												
PHL01	12/04/17	PASS												
	11/10/17	PASS												
	18/04/18	PASS												
	17/10/18	PASS												
PHL02	05/04/17	PASS												
	02/10/17	PASS												
	04/04/18	PASS												
	08/10/18	PASS												
PHL03	20/12/18	PASS												
PHL04	10/01/19	PASS												
PHL05	10/04/17	PASS												
	04/10/17	PASS												
	11/04/18	PASS												
	10/10/18	PASS												
PHL06	10/05/17	PASS												
	13/11/17	PASS												
	16/05/18	PASS												

Released under the Official Information Act 1982

FOR: PACIFIC HAULAGE LIMITED

TSL Licence Number: s13(c)(i)

Report Run dates between 28/02/2017 and 27/02/2019

			Air Systems	Brakes	Chassis	Exterior	Interior	Lighting	Motive	Steering	Towing	Suspension	Vehicle	Tyres	Other
	14/11/18	PASS													
PHL07	31/05/17	PASS													
	29/11/17	PASS													
	30/05/18	PASS													
	21/11/18	PASS													
PHL08	24/05/17	PASS													
	20/11/17	PASS													
	28/05/18	PASS													
	28/11/18	PASS													
PHL09	08/03/17	PASS													
	18/09/17	PASS													
	21/03/18	FAIL		1											
	19/09/18	PASS													
PHL10	03/08/18	PASS													
	07/01/19	PASS													
PHL13	15/12/17	PASS													
	21/05/18	PASS													
	26/11/18	PASS													
PHL14	17/05/17	PASS													
	15/11/17	PASS													
	23/05/18	PASS													
	30/10/18	PASS													
PHL15	23/08/17	PASS													
	21/02/18	PASS													
	22/08/18	PASS													
	13/02/19	PASS													
PHL16	19/07/17	PASS													
	29/12/17	PASS													

Released under the Official Information Act 1982

FOR: PACIFIC HAULAGE LIMITED

TSL Licence Number:

s18(c)(i)

Report Run dates between 28/02/2017 and 27/02/2019

		Air Systems	Brakes	Chassis	Exterior	Interior	Lighting	Motive	Steering	Towing	Suspension	Vehicle	Tyres	Other
	11/07/18	PASS												
	27/12/18	PASS												
PHL17	07/02/18	PASS												
	25/07/18	PASS												
	04/01/19	PASS												
PHL18	28/06/17	PASS												
	13/12/17	PASS												
	08/05/18	PASS												
	05/11/18	PASS												
PHL19	26/04/17	PASS												
	25/10/17	PASS												
	30/04/18	PASS												
	31/10/18	PASS												
PHL21	15/03/17	PASS												
	13/09/17	PASS												
	14/03/18	PASS												
	17/09/18	PASS												
PHL22	12/07/17	FAIL	1	1										
	03/01/18	PASS												
	18/07/18	PASS												
PHL23	24/04/17	PASS												
	30/10/17	PASS												
	23/04/18	PASS												
	24/10/18	PASS												
PHL25	16/10/17	PASS												
	27/04/18	PASS												
	29/10/18	FAIL	1											
PHL26	02/08/17	PASS												

Released under the Official Information Act 1982

FOR: PACIFIC HAULAGE LIMITED

TSL Licence Number: §18(c)(i)

Report Run dates between 28/02/2017 and 27/02/2019

		Air Systems	Brakes	Chassis	Exterior	Interior	Lighting	Motive	Steering	Towing	Suspension	Vehicle	Tyres	Other
	04/01/18	PASS												
	01/08/18	PASS												
	28/12/18	PASS												
PHL27	03/04/17	PASS												
	09/10/17	PASS												
	16/04/18	PASS												
	15/10/18	PASS												
PHL28	21/07/17	PASS												
	20/12/17	PASS												
	04/07/18	PASS												
	17/12/18	PASS												
PHL29	14/06/17	PASS												
	11/12/17	PASS												
	20/06/18	PASS												
	19/12/18	PASS												
PHL20	06/03/17	PASS												
	06/09/17	PASS												
	07/03/18	PASS												
	05/09/18	PASS												
	27/02/19	PASS												
PHL30	01/03/17	PASS												
	30/08/17	PASS												
	28/02/18	PASS												
	29/08/18	PASS												
	20/02/19	PASS												
PHL31	07/06/17	PASS												
	06/12/17	PASS												
	13/06/18	PASS												

Released under the Official Information Act 1982

FOR: PACIFIC HAULAGE LIMITED

TSL Licence Number: s18(c)(i)

Report Run dates between 28/02/2017 and 27/02/2019

			Air Systems	Brakes	Chassis	Exterior	Interior	Lighting	Motive	Steering	Towing	Suspension	Vehicle	Tyres	Other
	10/12/18	PASS													
PHL32	09/08/17	PASS													
	07/02/18	PASS													
	08/08/18	PASS													
	04/02/19	PASS													
PHL33	22/03/17	PASS													
	20/09/17	PASS													
	26/03/18	PASS													
	26/09/18	PASS													
PHL34	16/08/17	FAIL		1											
	14/02/18	PASS													
	15/08/18	PASS													
	11/02/19	PASS													
PHL35	08/05/17	PASS													
	08/11/17	PASS													
	02/05/18	PASS													
	07/11/18	PASS													
PHL36	25/09/17	PASS													
	14/03/18	PASS													
	12/09/18	PASS													
PHL37	20/07/17	PASS													
	08/12/17	FAIL		1											
	27/06/18	PASS													
	03/12/18	PASS													
PHL38	22/11/17	PASS													
	09/05/18	PASS													
	19/11/18	PASS													
PHL39	29/09/17	PASS													

Released under the Official Information Act 1982

FOR: PACIFIC HAULAGE LIMITED

TSL Licence Number:

s18(c)(i)

Report Run dates between 28/02/2017 and 27/02/2019

		Air Systems	Brakes	Chassis	Exterior	Interior	Lighting	Motive	Steering	Towing	Suspension	Vehicle	Tyres	Other
	12/03/18	PASS												
	10/09/18	PASS												
PHL40	02/11/17	PASS												
	05/03/18	PASS												
	24/09/18	PASS												
PHL41	17/05/18	PASS												
	12/11/18	PASS												
PHL42	13/07/18	PASS												
	12/12/18	PASS												
PHL43	24/07/18	PASS												
	03/01/19	PASS												
Q884L	24/04/17	PASS												
	30/10/17	PASS												
	23/04/18	PASS												
	24/10/18	PASS												
R177T	05/04/17	PASS												
	02/10/17	FAIL												
	04/04/18	FAIL												
	08/10/18	PASS												
R179F	28/06/17	PASS												
	13/12/17	PASS												
	24/05/18	PASS												
	05/11/18	PASS												
R443P	01/03/17	PASS												
	30/08/17	PASS												
	28/02/18	PASS												
	29/08/18	PASS												

Released under the Official Information Act 1982

FOR: PACIFIC HAULAGE LIMITED

TSL Licence Number:

s18(c)(i)

Report Run dates between 28/02/2017 and 27/02/2019

		Air Systems	Brakes	Chassis	Exterior	Interior	Lighting	Motive	Steering	Towing	Suspension	Vehicle	Tyres	Other
	20/02/19	PASS												
R462K	12/07/17	PASS												
	03/01/18	PASS												
	18/07/18	PASS												
	09/01/19	PASS												
S25E	19/07/17	PASS												
	29/12/17	PASS												
	11/07/18	PASS												
	27/12/18	PASS												
S532N	29/05/17	PASS												
	04/12/17	PASS												
	06/06/18	PASS												
	05/12/18	PASS												
S597H	26/04/17	PASS												
	25/10/17	PASS												
	30/04/18	PASS												
	31/10/18	PASS												
T672A	08/05/17	PASS												
	08/11/17	PASS												
	02/05/18	PASS												
	07/11/18	PASS												
T674A	06/03/17	PASS												
	06/09/17	PASS												
	07/03/18	PASS												
	05/09/18	PASS												
	27/02/19	PASS												
U789M	24/05/17	PASS												
	14/12/17	PASS												

Released under the Official Information Act 1982



FOR: PACIFIC HAULAGE LIMITED

TSL Licence Number: s18(c)(i)

Report Run dates between 28/02/2017 and 27/02/2019

		Air Systems	Brakes	Chassis	Exterior	Interior	Lighting	Motive	Steering	Towing	Suspension	Vehicle	Tyres	Other
	20/06/18	PASS												
	19/12/18	PASS												
U800M	15/03/17	PASS												
	13/09/17	PASS												
	14/03/18	PASS												
	17/09/18	PASS												
W198L	09/08/17	PASS												
	07/02/18	PASS												
	08/08/18	PASS												
	04/02/19	PASS												
W730M	22/03/17	FAIL	1											
	20/09/17	PASS												
	26/03/18	PASS												
	26/09/18	PASS												
W970G	07/06/17	FAIL	1	1										
	06/12/17	PASS												
	13/06/18	PASS												
	10/12/18	PASS												
Y951K	16/08/17	FAIL			1						1			
	14/02/18	PASS												
	15/08/18	PASS												
	11/02/19	PASS												
Z505Y	10/05/17	PASS												
	13/11/17	FAIL	1											
	16/05/18	PASS												
	14/11/18	PASS												
Z745L	08/03/17	PASS												
	18/09/17	PASS												

Released under the Official Information Act 1982

FOR: PACIFIC HAULAGE s18(c)(i)

TSL Licence Number:

Report Run dates between 28/02/2017 and 27/02/2019

		Air Systems	Brakes	Chassis	Exterior	Interior	Lighting	Motive	Steering	Towing	Suspension	Vehicle	Tyres	Other
	21/03/18	FAIL	1											
	19/09/18	PASS												
Z760L	12/04/17	PASS												
	11/10/17	PASS												
	18/04/18	PASS												
	17/10/18	PASS												

	Air Systems	Brakes	Chassis	Exterior	Interior	Lighting	Motive	Steering	Towing	Suspension	Vehicle	Tyres	Other
Total all faults	1	13	2	2		2			1	3			

Total No. of Vehicles Tested:	97
Total No. of actual faults for all Inspections:	24
Total No. of Failures:	19
Total No. of Passes:	321
Faults Per Vehicle:	0.25
Average Age of Vehicles:	6.66
Average No. of Faults for All Inspections:	0.07
Average No. faults on Failed Inspections:	1.26

Released under the Official Information Act 1982

**DETAILED VEHICLE AND INSPECTION REPORT**

FOR: PACIFIC HAULAGE LIMITED

Report Printed:

28-Feb-2019

TSL Licence Number: s18(c)(i)

Report run dates between 28/02/2017 and 27/02/2019

13Q38 34000 2018 / KRAFT 505  
TRAILER/CARAVAN / TRANSPORT LICENSED GOODS  
PACIFIC HAULAGE LIMITED

Re Inspection	Inspection Date	Days Presented Since COF Expiry	Result	Fault Code	Component	Fault	Location	Distance Travelled Hubo	Hubodometer Reading	Distance Travelled Odo	Odometer Reading
	07-Jan-2019		PASS						14691		1

Released under the Official Information Act 1982

**DETAILED VEHICLE AND INSPECTION REPORT**

FOR: PACIFIC HAULAGE LIMITED

Report Printed:

28-Feb-2019

TSL Licence Number: s18(c)(i)

Report run dates between 28/02/2017 and 27/02/2019

4Z305 34000 2016 / KRAFT 404 5A  
TRAILER/CARAVAN / TRANSPORT LICENSED GOODS  
PACIFIC HAULAGE LTD

Re Inspection	Inspection Date	Days Presented Since COF Expiry	Result	Fault Code	Component	Fault	Location	Distance Travelled Hubo	Hubodometer Reading	Distance Travelled Odo	Odometer Reading
	02-Aug-2017		PASS						55669		1
	04-Jan-2018	-30	PASS						75143		1
	01-Aug-2018	0	PASS						101309		1
	28-Dec-2018	-35	PASS						122180		1

Released under the Official Information Act 1982

**DETAILED VEHICLE AND INSPECTION REPORT**

FOR: PACIFIC HAULAGE LIMITED

Report Printed: 28-Feb-2019

TSL Licence Number: s18(c)(i)

Report run dates between 28/02/2017 and 27/02/2019

5W717 34000 2016 / KRAFT 400 5A  
TRAILER/CARAVAN / TRANSPORT LICENSED GOODS  
PACIFIC HAULAGE LTD

Re Inspection	Inspection Date	Days Presented Since COF Expiry	Result	Fault Code	Component	Fault	Location	Distance Travelled Hubo	Hubodometer Reading	Distance Travelled Odo	Odometer Reading
	03-Apr-2017		PASS						5433		1
	09-Oct-2017	-22	PASS						36341		1
	16-Apr-2018	-14	PASS						66937		1
	15-Oct-2018	-15	PASS						96477		1

Released under the Official Information Act 1982

**DETAILED VEHICLE AND INSPECTION REPORT**

FOR: PACIFIC HAULAGE LIMITED

Report Printed:

28-Feb-2019

TSL Licence Number: s18(c)(i)

Report run dates between 28/02/2017 and 27/02/2019

6F838 34000 2017 / KRAFT 400 5A  
TRAILER/CARAVAN / TRANSPORT LICENSED GOODS  
PACIFIC HAULAGE LTD

Re Inspection	Inspection Date	Days Presented Since COF Expiry	Result	Fault Code	Component	Fault	Location	Distance Travelled Hubo	Hubodometer Reading	Distance Travelled Odo	Odometer Reading
	21-Jul-2017		PASS						17015		1
	20-Dec-2017	-44	PASS						37320		1
	04-Jul-2018	-14	PASS						59076		1
	17-Dec-2018	-32	PASS						82788		1

Released under the Official Information Act 1982

### DETAILED VEHICLE AND INSPECTION REPORT

FOR: PACIFIC HAULAGE LIMITED

Report Printed:

28-Feb-2019

TSL Licence Number: s18(c)(i)

Report run dates between 28/02/2017 and 27/02/2019

6Y910 34000 2017 / KRAFT 400 5A  
TRAILER/CARAVAN / TRANSPORT LICENSED GOODS  
PACIFIC HAULAGE LTD

Re Inspection	Inspection Date	Days Presented Since COF Expiry	Result	Fault Code	Component	Fault	Location	Distance Travelled Hubo	Hubodometer Reading	Distance Travelled Odo	Odometer Reading
	25-Sep-2017		PASS						23250		1
	19-Mar-2018	59	PASS						37557		1
	12-Sep-2018	-7	PASS						62031		1

Released under the Official Information Act 1982

**DETAILED VEHICLE AND INSPECTION REPORT**

FOR: PACIFIC HAULAGE LIMITED

Report Printed:

28-Feb-2019

TSL Licence Number: s18(c)(i)

Report run dates between 28/02/2017 and 27/02/2019

7B837 34000 2017 / KRAFT 400 5A  
TRAILER/CARAVAN / TRANSPORT LICENSED GOODS  
PACIFIC HAULAGE LTD

Re Inspection	Inspection Date	Days Presented Since COF Expiry	Result	Fault Code	Component	Fault	Location	Distance Travelled Hubo	Hubodometer Reading	Distance Travelled Odo	Odometer Reading
	16-Oct-2017		PASS						27415		1
	27-Apr-2018	-1	PASS						57843		1
	29-Oct-2018	0	PASS						82451		1

Released under the Official Information Act 1982



**DETAILED VEHICLE AND INSPECTION REPORT**

FOR: PACIFIC HAULAGE LIMITED

Report Printed:

28-Feb-2019

TSL Licence Number: s18(c)(i)

Report run dates between 28/02/2017 and 27/02/2019

7K728 34000 2017 / KRAFT 400 5A  
TRAILER/CARAVAN / TRANSPORT LICENSED GOODS  
PACIFIC HAULAGE LIMITED

Re Inspection	Inspection Date	Days Presented Since COF Expiry	Result	Fault Code	Component	Fault	Location	Distance Travelled Hubo	Hubodometer Reading	Distance Travelled Odo	Odometer Reading
	22-Nov-2017		PASS						25395		1
	09-May-2018	-41	PASS						50748		1
	19-Nov-2018	-18	PASS						82578		1

Released under the Official Information Act 1982

**DETAILED VEHICLE AND INSPECTION REPORT**

FOR: PACIFIC HAULAGE LIMITED

Report Printed: 28-Feb-2019

TSL Licence Number: s18(c)(i)

Report run dates between 28/02/2017 and 27/02/2019

7P447 34000 2017 / KRAFT 400 5A  
TRAILER/CARAVAN / TRANSPORT LICENSED GOODS  
PACIFIC HAULAGE LIMITED

Re Inspection	Inspection Date	Days Presented Since COF Expiry	Result	Fault Code	Component	Fault	Location	Distance Travelled Hubo	Hubodometer Reading	Distance Travelled Odo	Odometer Reading
	08-Dec-2017		PASS						16901		1
	27-Jun-2018	-9	PASS						31769		1
	03-Dec-2018	-34	PASS						52382		1

Released under the Official Information Act 1982

**DETAILED VEHICLE AND INSPECTION REPORT**

FOR: PACIFIC HAULAGE LIMITED

Report Printed:

28-Feb-2019

TSL Licence Number: s18(c)(i)

Report run dates between 28/02/2017 and 27/02/2019

7U983 34000 2017 / KRAFT 404 5A  
TRAILER/CARAVAN / TRANSPORT LICENSED GOODS  
PACIFIC HAULAGE LIMITED

Re Inspection	Inspection Date	Days Presented Since COF Expiry	Result	Fault Code	Component	Fault	Location	Distance Travelled Hubo	Hubodometer Reading	Distance Travelled Odo	Odometer Reading
	05-Mar-2018		PASS						16463		1
	24-Sep-2018	-2	PASS						41655		1

Released under the Official Information Act 1982

### DETAILED VEHICLE AND INSPECTION REPORT

FOR: PACIFIC HAULAGE LIMITED

Report Printed:

28-Feb-2019

TSL Licence Number: s18(c)(i)

Report run dates between 28/02/2017 and 27/02/2019

8A839 34000 2017 / KRAFT 404 5A  
TRAILER/CARAVAN / TRANSPORT LICENSED GOODS  
PACIFIC HAULAGE LIMITED

Re Inspection	Inspection Date	Days Presented Since COF Expiry	Result	Fault Code	Component	Fault	Location	Distance Travelled Hubo	Hubodometer Reading	Distance Travelled Odo	Odometer Reading
	12-Mar-2018		PASS						28370		1
	10-Sep-2018	-9	PASS						60776		1

Released under the Official Information Act 1982

**DETAILED VEHICLE AND INSPECTION REPORT**

FOR: PACIFIC HAULAGE LIMITED

Report Printed: 28-Feb-2019

TSL Licence Number: s18(c)(i)

Report run dates between 28/02/2017 and 27/02/2019

8K642 34000 2017 / KRAFT 404 5A  
TRAILER/CARAVAN / TRANSPORT LICENSED GOODS  
PACIFIC HAULAGE LIMITED

Re Inspection	Inspection Date	Days Presented Since COF Expiry	Result	Fault Code	Component	Fault	Location	Distance Travelled Hubo	Hubodometer Reading	Distance Travelled Odo	Odometer Reading
	21-May-2018		PASS						19961		1
	26-Nov-2018	-3	PASS						55261		1

Released under the Official Information Act 1982

### DETAILED VEHICLE AND INSPECTION REPORT

FOR: PACIFIC HAULAGE LIMITED

Report Printed:

28-Feb-2019

TSL Licence Number: s18(c)(i)

Report run dates between 28/02/2017 and 27/02/2019

9C103 34000 2018 / KRAFT 505  
TRAILER/CARAVAN / TRANSPORT LICENSED GOODS  
PACIFIC HAULAGE LIMITED

Re Inspection	Inspection Date	Days Presented Since COF Expiry	Result	Fault Code	Component	Fault	Location	Distance Travelled Hubo	Hubodometer Reading	Distance Travelled Odo	Odometer Reading
	25-Jul-2018		PASS						16233		1
	04-Jan-2019	-32	PASS						35425		1

Released under the Official Information Act 1982

**DETAILED VEHICLE AND INSPECTION REPORT**

FOR: PACIFIC HAULAGE LIMITED

Report Printed: 28-Feb-2019

TSL Licence Number: s18(c)(i)

Report run dates between 28/02/2017 and 27/02/2019

9Z506 34000 2018 / KRAFT 507  
TRAILER/CARAVAN / TRANSPORT LICENSED GOODS  
PACIFIC HAULAGE LIMITED

Re Inspection	Inspection Date	Days Presented Since COF Expiry	Result	Fault Code	Component	Fault	Location	Distance Travelled Hubo	Hubodometer Reading	Distance Travelled Odo	Odometer Reading
	12-Nov-2018		PASS						15896		1

Released under the Official Information Act 1982

**DETAILED VEHICLE AND INSPECTION REPORT**

FOR: PACIFIC HAULAGE LIMITED

Report Printed: 28-Feb-2019

TSL Licence Number: s18(c)(i)

Report run dates between 28/02/2017 and 27/02/2019

9Z511 34000 2018 / KRAFT 505  
TRAILER/CARAVAN / TRANSPORT LICENSED GOODS  
PACIFIC HAULAGE LIMITED

Re Inspection	Inspection Date	Days Presented Since COF Expiry	Result	Fault Code	Component	Fault	Location	Distance Travelled Hubo	Hubodometer Reading	Distance Travelled Odo	Odometer Reading
	12-Dec-2018		PASS						22468		1

Released under the Official Information Act 1982



**DETAILED VEHICLE AND INSPECTION REPORT**

FOR: PACIFIC HAULAGE LIMITED

Report Printed: 28-Feb-2019

TSL Licence Number: s18(c)(i)

Report run dates between 28/02/2017 and 27/02/2019

9Z516 34000 2018 / KRAFT 505  
TRAILER/CARAVAN / TRANSPORT LICENSED GOODS  
PACIFIC HAULAGE LIMITED

Re Inspection	Inspection Date	Days Presented Since COF Expiry	Result	Fault Code	Component	Fault	Location	Distance Travelled Hubo	Hubodometer Reading	Distance Travelled Odo	Odometer Reading
	03-Jan-2019		PASS						21269		1

Released under the Official Information Act 1982

**DETAILED VEHICLE AND INSPECTION REPORT**

FOR: PACIFIC HAULAGE LIMITED

Report Printed: 28-Feb-2019

TSL Licence Number: s18(c)(i)

Report run dates between 28/02/2017 and 27/02/2019

AYC954 8000 2002 / MITSUBISHI CANTER FE155F4  
GOODS VAN/TRUCK/UTILITY / TRANSPORT LICENSED GOODS  
PACIFIC HAULAGE LTD

Re Inspection	Inspection Date	Days Presented Since COF Expiry	Result	Fault Code	Component	Fault	Location	Distance Travelled Hubo	Hubodometer Reading	Distance Travelled Odo	Odometer Reading
	29-Mar-2017		PASS						91644		343696
	29-Sep-2017	-1	PASS						96147		348100
	29-Mar-2018	-1	PASS						101574		353414
	21-Sep-2018	-9	FAIL	BSI2	SERVICE BRAKE	TO IMPROVE	FRONT		103887		355681
*	25-Sep-2018		PASS					10	103897		355691

Released under the Official Information Act 1982

**DETAILED VEHICLE AND INSPECTION REPORT**

FOR: PACIFIC HAULAGE LIMITED

Report Printed:

28-Feb-2019

TSL Licence Number: s18(c)(i)

Report run dates between 28/02/2017 and 27/02/2019

GDU506 32900 2011 / KENWORTH T 408  
GOODS VAN/TRUCK/UTILITY / TRANSPORT LICENSED GOODS  
PACIFIC HAULAGE LTD

Re Inspection	Inspection Date	Days Presented Since COF Expiry	Result	Fault Code	Component	Fault	Location	Distance Travelled Hubo	Hubodometer Reading	Distance Travelled Odo	Odometer Reading
	29-May-2017		PASS						81993		1
	04-Dec-2017	-1	PASS						125994		1
	06-Jun-2018	0	PASS						160910		1
	05-Dec-2018	-1	PASS						197893		1

Released under the Official Information Act 1982

**DETAILED VEHICLE AND INSPECTION REPORT**

FOR: PACIFIC HAULAGE LIMITED

Report Printed: 28-Feb-2019

TSL Licence Number: s18(c)(i)

Report run dates between 28/02/2017 and 27/02/2019

H469A 25000 2006 / EVANS 4AC  
TRAILER/CARAVAN / TRANSPORT LICENSED GOODS  
PACIFIC HAULAGE LTD

Re Inspection	Inspection Date	Days Presented Since COF Expiry	Result	Fault Code	Component	Fault	Location	Distance Travelled Hubo	Hubodometer Reading	Distance Travelled Odo	Odometer Reading
	31-May-2017		PASS						0		1
	29-Nov-2017	-4	PASS						996		1
	30-May-2018	-4	PASS						14054		1
	21-Nov-2018	-12	PASS						36411		1

Released under the Official Information Act 1982

**DETAILED VEHICLE AND INSPECTION REPORT**

FOR: PACIFIC HAULAGE LIMITED

Report Printed: 28-Feb-2019

TSL Licence Number: s18(c)(i)

Report run dates between 28/02/2017 and 27/02/2019

J169L 30000 2007 / KRAFT 400  
TRAILER/CARAVAN / TRANSPORT LICENSED GOODS  
PACIFIC HAULAGE LTD

Re Inspection	Inspection Date	Days Presented Since COF Expiry	Result	Fault Code	Component	Fault	Location	Distance Travelled Hubo	Hubodometer Reading	Distance Travelled Odo	Odometer Reading
	15-Aug-2017		PASS						581		1
	05-Feb-2019	354	PASS						591		1

Released under the Official Information Act 1982

**DETAILED VEHICLE AND INSPECTION REPORT**

FOR: PACIFIC HAULAGE LIMITED

Report Printed:

28-Feb-2019

TSL Licence Number: s18(c)(i)

Report run dates between 28/02/2017 and 27/02/2019

J765S 30000 2007 / KRAFT 404  
TRAILER/CARAVAN / TRANSPORT LICENSED GOODS  
EARL JAMES ANDERSON

Re Inspection	Inspection Date	Days Presented Since COF Expiry	Result	Fault Code	Component	Fault	Location	Distance Travelled Hubo	Hubodometer Reading	Distance Travelled Odo	Odometer Reading
	25-Mar-2017		PASS						407576		0
	29-Sep-2017	-24	PASS						437019		0
	28-Apr-2018	4	PASS						14713		0
	25-Oct-2018	-3	PASS						44323		0

Released under the Official Information Act 1982

**DETAILED VEHICLE AND INSPECTION REPORT**

FOR: PACIFIC HAULAGE LIMITED

Report Printed: 28-Feb-2019

TSL Licence Number: s18(c)(i)

Report run dates between 28/02/2017 and 27/02/2019

J816F 30000 2007 / KRAFT 400  
TRAILER/CARAVAN / TRANSPORT LICENSED GOODS  
PACIFIC HAULAGE LTD

Re Inspection	Inspection Date	Days Presented Since COF Expiry	Result	Fault Code	Component	Fault	Location	Distance Travelled Hubo	Hubodometer Reading	Distance Travelled Odo	Odometer Reading
	21-Jun-2017		PASS						67554		0
	20-Nov-2017	-40	PASS						67843		0
	28-May-2018	-20	PASS						85464		0
	28-Nov-2018	-19	PASS						105561		0

Released under the Official Information Act 1982

**DETAILED VEHICLE AND INSPECTION REPORT**

FOR: PACIFIC HAULAGE LIMITED

Report Printed:

28-Feb-2019

TSL Licence Number: s18(c)(i)

Report run dates between 28/02/2017 and 27/02/2019

J880M 26000 2001 / EVANS 4AS 4A4B  
TRAILER/CARAVAN / TRANSPORT LICENSED GOODS  
GRAEME OWEN KELLY

Re Inspection	Inspection Date	Days Presented Since COF Expiry	Result	Fault Code	Component	Fault	Location	Distance Travelled Hubo	Hubodometer Reading	Distance Travelled Odo	Odometer Reading
	14-Jun-2017		FAIL	EAS1	STRUCTURE	CRACKED	ALL		152404		0
	14-Jun-2017		FAIL	UHS8	SPRING HNGR/SLIPR	CRACKED	LEFT REAR		152404		0
*	15-Jun-2017		PASS					8	152412	0	0
	11-Dec-2017	-11	PASS						174653		0
	10-Oct-2018	109	PASS						190049		0

Released under the Official Information Act 1982



**DETAILED VEHICLE AND INSPECTION REPORT**

FOR: PACIFIC HAULAGE LIMITED

Report Printed:

28-Feb-2019

TSL Licence Number: s9(2)

Report run dates between 28/02/2017 and 27/02/2019

K239N 30000 2007 / KRAFT 404  
TRAILER/CARAVAN / TRANSPORT LICENSED GOODS  
SHANE STEVEN HATCHER

Re Inspection	Inspection Date	Days Presented Since COF Expiry	Result	Fault Code	Component	Fault	Location	Distance Travelled Hubo	Hubodometer Reading	Distance Travelled Odo	Odometer Reading
	29-Mar-2017		PASS						170690		0
	27-Sep-2017	-3	PASS						192671		0
	29-Dec-2017	-91	PASS						201670		0
	02-Jul-2018	-25	PASS						221276		0
	21-Jan-2019	-6	PASS						10839		0

Released under the Official Information Act 1982

**DETAILED VEHICLE AND INSPECTION REPORT**

FOR: PACIFIC HAULAGE LIMITED

Report Printed:

28-Feb-2019

TSL Licence Number: s18(c)(i)

Report run dates between 28/02/2017 and 27/02/2019

K436A 30000 2007 / KRAFT 404  
TRAILER/CARAVAN / TRANSPORT LICENSED GOODS  
MCAULEYS TRANSPORT LIMITED

Re Inspection	Inspection Date	Days Presented Since COF Expiry	Result	Fault Code	Component	Fault	Location	Distance Travelled Hubo	Hubodometer Reading	Distance Travelled Odo	Odometer Reading
	03-May-2017		PASS						192525		0
	06-Nov-2017	1	PASS						215449		0
	18-Apr-2018	-18	PASS						224074		0
	05-Nov-2018	-1	PASS						247337		1

Released under the Official Information Act 1982

**DETAILED VEHICLE AND INSPECTION REPORT**

FOR: PACIFIC HAULAGE LIMITED

Report Printed:

28-Feb-2019

TSL Licence Number: s18(c)(i)

Report run dates between 28/02/2017 and 27/02/2019

K438A 30000 2007 / KRAFT 404  
TRAILER/CARAVAN / TRANSPORT LICENSED GOODS  
OM MIBILE FORKLIFT AND GENERAL MECHANICAL CONTRACTORS LT

Re Inspection	Inspection Date	Days Presented Since COF Expiry	Result	Fault Code	Component	Fault	Location	Distance Travelled Hubo	Hubodometer Reading	Distance Travelled Odo	Odometer Reading
	01-May-2017		PASS						99427		0
	01-Nov-2017	-16	PASS						13523		0
	13-Mar-2018	-65	PASS						21007		0
	18-Oct-2018	6	PASS						34222		0
*	14-Nov-2018	0	FAIL	CCW4	CROSS MEMBERS	WORN	LEFT	2,880	37102	0	0
	14-Nov-2018		FAIL	CRW4	CHASSIS RAILS	WORN	LEFT		37102		0
	14-Nov-2018		FAIL	EAW1	STRUCTURE	WORN	ALL		37102		0
	14-Nov-2018		FAIL	EAW3	STRUCTURE	WORN	REAR		37102		0
	14-Nov-2018		FAIL	EUU2	LOG BOLSTERS	LOOSE	FRONT		37102		0
*	15-Nov-2018		PASS					9	37111		0

Released under the Official Information Act 1982

**DETAILED VEHICLE AND INSPECTION REPORT**

FOR: PACIFIC HAULAGE LIMITED

Report Printed: 28-Feb-2019

TSL Licence Number: s18(c)(i)

Report run dates between 28/02/2017 and 27/02/2019

K898F 30000 2007 / KRAFT 400  
TRAILER/CARAVAN / TRANSPORT LICENSED GOODS  
PACIFIC HAULAGE LTD

Re Inspection	Inspection Date	Days Presented Since COF Expiry	Result	Fault Code	Component	Fault	Location	Distance Travelled Hubo	Hubodometer Reading	Distance Travelled Odo	Odometer Reading
	10-Apr-2017		PASS						26890		0
	04-Oct-2017	-9	PASS						42088		0
	11-Apr-2018	-2	PASS						61633		0
	10-Oct-2018	-3	PASS						83720		0

Released under the Official Information Act 1982

**DETAILED VEHICLE AND INSPECTION REPORT**

FOR: PACIFIC HAULAGE LIMITED

Report Printed:

28-Feb-2019

TSL Licence Number: s18(c)(i)

Report run dates between 28/02/2017 and 27/02/2019

KWB512 32000 2001 / KENWORTH K104  
GOODS VAN/TRUCK/UTILITY / TRANSPORT LICENSED GOODS

Re Inspection	Inspection Date	Days Presented Since COF Expiry	Result	Fault Code	Component	Fault	Location	Distance Travelled Hubo	Hubodometer Reading	Distance Travelled Odo	Odometer Reading
	26-Jul-2017		PASS						242666		1
	12-Sep-2017	-140	PASS						247137		1
	18-Apr-2018	8	FAIL	BSM2	SERVICE BRAKE	MATCH	FRONT		54472		1
	18-Apr-2018		FAIL	BSM3	SERVICE BRAKE	MATCH	REAR		54472		1
*	18-Apr-2018		PASS					23	54495	0	1
	30-Oct-2018	11	PASS						103601		1

Released under the Official Information Act 1982

**DETAILED VEHICLE AND INSPECTION REPORT**

FOR: PACIFIC HAULAGE LIMITED

Report Printed: 28-Feb-2019

TSL Licence Number: s18(c)(i)

Report run dates between 28/02/2017 and 27/02/2019

KYG607 26900 1994 / KENWORTH T 950  
GOODS VAN/TRUCK/UTILITY / TRANSPORT LICENSED GOODS  
ALAN G GIBSON LTD

Re Inspection	Inspection Date	Days Presented Since COF Expiry	Result	Fault Code	Component	Fault	Location	Distance Travelled Hubo	Hubodometer Reading	Distance Travelled Odo	Odometer Reading
	21-Jun-2017		FAIL	TMP3	DRAWBEAM	TO PRODUCE	REAR		163510		332234
	15-Aug-2017		PASS						163527		332234
	19-Feb-2018	3	PASS						1995		333223
	23-Jul-2018	-27	PASS						7675		332234

Released under the Official Information Act 1982

**DETAILED VEHICLE AND INSPECTION REPORT**

FOR: PACIFIC HAULAGE LIMITED

Report Printed:

28-Feb-2019

TSL Licence Number: s18(c)(i)

Report run dates between 28/02/2017 and 27/02/2019

L402L 30000 2008 / KRAFT 404  
TRAILER/CARAVAN / TRANSPORT LICENSED GOODS  
ABBOTT HOLDINGS LIMITED

Re Inspection	Inspection Date	Days Presented Since COF Expiry	Result	Fault Code	Component	Fault	Location	Distance Travelled Hubo	Hubodometer Reading	Distance Travelled Odo	Odometer Reading
	05-Jul-2017		PASS						136218		1
	27-Dec-2017	-17	PASS						157970		1
	14-Jun-2018	-29	PASS						169506		1
	11-Jan-2019	0	PASS						180409		1

Released under the Official Information Act 1982

**DETAILED VEHICLE AND INSPECTION REPORT**

FOR: PACIFIC HAULAGE LIMITED

Report Printed: 28-Feb-2019

TSL Licence Number: s18(c)(i)

Report run dates between 28/02/2017 and 27/02/2019

LCL769 32000 2007 / KENWORTH T 404S  
GOODS VAN/TRUCK/UTILITY / TRANSPORT LICENSED GOODS  
ABBOT HOLDINGS LIMITED

Re Inspection	Inspection Date	Days Presented Since COF Expiry	Result	Fault Code	Component	Fault	Location	Distance Travelled Hubo	Hubodometer Reading	Distance Travelled Odo	Odometer Reading
	29-Mar-2017		PASS						25820		1
	27-Sep-2017	-3	PASS						71224		1
	29-Dec-2017	-91	PASS						89534		1
	02-Jul-2018	-25	FAIL	BSM3	SERVICE BRAKE	MATCH	REAR		38835		1
*	03-Jul-2018		PASS					11	38846	0	1
	09-Jan-2019	-18	PASS						91900		1

Released under the Official Information Act 1982



**DETAILED VEHICLE AND INSPECTION REPORT**

FOR: PACIFIC HAULAGE LIMITED

Report Printed: 28-Feb-2019

TSL Licence Number: s18(c)(i)

Report run dates between 28/02/2017 and 27/02/2019

LGC224 32000 2007 / KENWORTH K104  
GOODS VAN/TRUCK/UTILITY / TRANSPORT LICENSED GOODS  
ON MOBILE FORKLIFT&GENERAL MECHANICAL CONTRACTORS LIMITE

Re Inspection	Inspection Date	Days Presented Since COF Expiry	Result	Fault Code	Component	Fault	Location	Distance Travelled Hubo	Hubodometer Reading	Distance Travelled Odo	Odometer Reading
	01-May-2017		PASS						204533		1
	01-Nov-2017	-1	PASS						241309		1
	13-Mar-2018	-50	PASS						256377		1
	17-Oct-2018	5	PASS						24735		1

Released under the Official Information Act 1982

**DETAILED VEHICLE AND INSPECTION REPORT**

FOR: PACIFIC HAULAGE LIMITED

Report Printed: 28-Feb-2019

TSL Licence Number: s18(c)(i)

Report run dates between 28/02/2017 and 27/02/2019

LHM253 32000 2007 / KENWORTH K104  
GOODS VAN/TRUCK/UTILITY / TRANSPORT LICENSED GOODS  
MCAULEYS TRANSPORT LIMITED

Re Inspection	Inspection Date	Days Presented Since COF Expiry	Result	Fault Code	Component	Fault	Location	Distance Travelled Hubo	Hubodometer Reading	Distance Travelled Odo	Odometer Reading
	03-May-2017		PASS						246893		887718
	06-Nov-2017	-4	FAIL	ULY1	SPRINGS	TO COMPLY	ALL		295940		933824
*	06-Nov-2017		PASS					11	295951	11	933835
	18-Apr-2018	-22	PASS						315175		951711
	05-Nov-2018	-5	PASS						45523		997702

Released under the Official Information Act 1982

DETAILED VEHICLE AND INSPECTION REPORT

FOR: PACIFIC HAULAGE LIMITED

Report Printed:

28-Feb-2019

TSL Licence Number: s18(c)(i)

Report run dates between 28/02/2017 and 27/02/2019

LMF809 32000 2008 / KENWORTH T 404S  
GOODS VAN/TRUCK/UTILITY / TRANSPORT LICENSED GOODS  
ABBOTT HOLDINGS LIMITED

Re Inspection	Inspection Date	Days Presented Since COF Expiry	Result	Fault Code	Component	Fault	Location	Distance Travelled Hubo	Hubodometer Reading	Distance Travelled Odo	Odometer Reading
	05-Jul-2017		PASS						287663		1
	27-Dec-2017	-17	PASS						330740		1
	14-Jun-2018	-29	PASS						353168		1
	16-Jan-2019	4	PASS						21507		1

Released under the Official Information Act 1982

**DETAILED VEHICLE AND INSPECTION REPORT**

FOR: PACIFIC HAULAGE LIMITED

Report Printed:

28-Feb-2019

TSL Licence Number: s18(c)(i)

Report run dates between 28/02/2017 and 27/02/2019

LUM43 32000 2008 / KENWORTH T 404S  
GOODS VAN/TRUCK/UTILITY / TRANSPORT LICENSED GOODS  
RALEIGH BULK HAULAGE LTD

Re Inspection	Inspection Date	Days Presented Since COF Expiry	Result	Fault Code	Component	Fault	Location	Distance Travelled Hubo	Hubodometer Reading	Distance Travelled Odo	Odometer Reading
	19-Apr-2017		PASS						266692		1
	18-Oct-2017	-6	PASS						310785		1
	28-Mar-2018	-27	PASS						348007		1
	03-Oct-2018	-21	PASS						376868		1

Released under the Official Information Act 1982

**DETAILED VEHICLE AND INSPECTION REPORT**

FOR: PACIFIC HAULAGE LIMITED

Report Printed: 28-Feb-2019

TSL Licence Number: s18(c)(i)

Report run dates between 28/02/2017 and 27/02/2019

M675K 30000 2008 / KRAFT 404  
TRAILER/CARAVAN / TRANSPORT LICENSED GOODS  
ABBOTT HOLDINGS LTD

Re Inspection	Inspection Date	Days Presented Since COF Expiry	Result	Fault Code	Component	Fault	Location	Distance Travelled Hubo	Hubodometer Reading	Distance Travelled Odo	Odometer Reading
	26-Jul-2017		PASS						138868		1
	12-Sep-2017	-140	PASS						140987		1
	18-Apr-2018	8	FAIL	BSM2	SERVICE BRAKE	MATCH	FRONT		167657		1
*	19-Apr-2018		PASS					13	167670	0	1
	06-Nov-2018	17	FAIL	LIO1	DIR INDCATR LAMPS	TO OPERATE	ALL		192156		1
	06-Nov-2018		FAIL	LSO1	STOP LAMPS	TO OPERATE	ALL		192156		1
*	07-Nov-2018		PASS					6	192162		1

Released under the Official Information Act 1982

**DETAILED VEHICLE AND INSPECTION REPORT**

FOR: PACIFIC HAULAGE LIMITED

Report Printed:

28-Feb-2019

TSL Licence Number: s18(c)(i)

Report run dates between 28/02/2017 and 27/02/2019

M829A 30000 2008 / KRAFT 404  
TRAILER/CARAVAN / TRANSPORT LICENSED GOODS  
RALEIGH BULK HAULAGE LTD

Re Inspection	Inspection Date	Days Presented Since COF Expiry	Result	Fault Code	Component	Fault	Location	Distance Travelled Hubo	Hubodometer Reading	Distance Travelled Odo	Odometer Reading
	19-Apr-2017		PASS						55502		1
	03-Oct-2017	0	PASS						75345		1
	28-Mar-2018	-6	PASS						95246		1
	03-Oct-2018	0	PASS						109359		1

Released under the Official Information Act 1982

**DETAILED VEHICLE AND INSPECTION REPORT**

FOR: PACIFIC HAULAGE LIMITED

Report Printed:

28-Feb-2019

TSL Licence Number: s18(c)(i)

Report run dates between 28/02/2017 and 27/02/2019

N102T 30000 2009 / KRAFT 404  
TRAILER/CARAVAN / TRANSPORT LICENSED GOODS  
PACIFIC HAULAGE LTD

Re Inspection	Inspection Date	Days Presented Since COF Expiry	Result	Fault Code	Component	Fault	Location	Distance Travelled Hubo	Hubodometer Reading	Distance Travelled Odo	Odometer Reading
	17-May-2017		PASS						115694		1
	15-Nov-2017	-11	PASS						25425		1
	23-May-2018	-3	PASS						50262		1
	30-Oct-2018	74	PASS						55797		1

Released under the Official Information Act 1982

DETAILED VEHICLE AND INSPECTION REPORT

FOR: PACIFIC HAULAGE LIMITED

Report Printed:

28-Feb-2019

TSL Licence Number: s18(c)(i)

Report run dates between 28/02/2017 and 27/02/2019

P352C 30000 2009 / KRAFT 404  
TRAILER/CARAVAN / TRANSPORT LICENSED GOODS  
PACIFIC HAULAGE LTD

Re Inspection	Inspection Date	Days Presented Since COF Expiry	Result	Fault Code	Component	Fault	Location	Distance Travelled Hubo	Hubodometer Reading	Distance Travelled Odo	Odometer Reading
	23-Aug-2017		PASS						216054		1
	21-Feb-2018	-27	PASS						240058		1
	22-Aug-2018	-29	PASS						260211		1
	13-Feb-2019	-37	PASS						289605		1

Released under the Official Information Act 1982



**DETAILED VEHICLE AND INSPECTION REPORT**

FOR: PACIFIC HAULAGE LIMITED

Report Printed:

28-Feb-2019

TSL Licence Number: s18(c)(i)

Report run dates between 28/02/2017 and 27/02/2019

PHL01 32900 2014 / KENWORTH T 659  
GOODS VAN/TRUCK/UTILITY / TRANSPORT LICENSED GOODS  
PACIFIC HAULAGE LTD

Re Inspection	Inspection Date	Days Presented Since COF Expiry	Result	Fault Code	Component	Fault	Location	Distance Travelled Hubo	Hubodometer Reading	Distance Travelled Odo	Odometer Reading
	12-Apr-2017		PASS						262427		262637
	11-Oct-2017	-24	PASS						13256		312888
	18-Apr-2018	-16	PASS						52962		352807
	17-Oct-2018	-18	PASS						105323		405401

Released under the Official Information Act 1982

**DETAILED VEHICLE AND INSPECTION REPORT**

FOR: PACIFIC HAULAGE LIMITED

Report Printed:

28-Feb-2019

TSL Licence Number: s18(c)(i)

Report run dates between 28/02/2017 and 27/02/2019

PHL02 32900 2011 / KENWORTH K108  
GOODS VAN/TRUCK/UTILITY / TRANSPORT LICENSED GOODS  
PACIFIC HAULAGE LTD

Re Inspection	Inspection Date	Days Presented Since COF Expiry	Result	Fault Code	Component	Fault	Location	Distance Travelled Hubo	Hubodometer Reading	Distance Travelled Odo	Odometer Reading
	05-Apr-2017		PASS						287721		1
	02-Oct-2017	-5	PASS						333961		1
	04-Apr-2018	-3	PASS						368365		1
	08-Oct-2018	0	PASS						410533		1

Released under the Official Information Act 1982

**DETAILED VEHICLE AND INSPECTION REPORT**

FOR: PACIFIC HAULAGE LIMITED

Report Printed: 28-Feb-2019

TSL Licence Number: s18(c)(i)

Report run dates between 28/02/2017 and 27/02/2019

PHL03 28500 2018 / KENWORTH T 659  
GOODS VAN/TRUCK/UTILITY / TRANSPORT LICENSED GOODS  
PACIFIC HAULAGE LTD

Re Inspection	Inspection Date	Days Presented Since COF Expiry	Result	Fault Code	Component	Fault	Location	Distance Travelled Hubo	Hubodometer Reading	Distance Travelled Odo	Odometer Reading
	20-Dec-2018		PASS						16		601

Released under the Official Information Act 1982

**DETAILED VEHICLE AND INSPECTION REPORT**

FOR: PACIFIC HAULAGE LIMITED

Report Printed: 28-Feb-2019

TSL Licence Number: s18(c)(i)

Report run dates between 28/02/2017 and 27/02/2019

PHL04 28500 2019 / KENWORTH T 659  
GOODS VAN/TRUCK/UTILITY / TRANSPORT LICENSED GOODS  
PACIFIC HAULAGE LTD

Re Inspection	Inspection Date	Days Presented Since COF Expiry	Result	Fault Code	Component	Fault	Location	Distance Travelled Hubo	Hubodometer Reading	Distance Travelled Odo	Odometer Reading
	10-Jan-2019		PASS						0		601

Released under the Official Information Act 1982

**DETAILED VEHICLE AND INSPECTION REPORT**

FOR: PACIFIC HAULAGE LIMITED

Report Printed: 28-Feb-2019

TSL Licence Number: s18(c)(i)

Report run dates between 28/02/2017 and 27/02/2019

PHL05 32000 2007 / KENWORTH T 404S  
GOODS VAN/TRUCK/UTILITY / TRANSPORT LICENSED GOODS  
PACIFIC HAULAGE LTD

Re Inspection	Inspection Date	Days Presented Since COF Expiry	Result	Fault Code	Component	Fault	Location	Distance Travelled Hubo	Hubodometer Reading	Distance Travelled Odo	Odometer Reading
	10-Apr-2017		PASS						259980		670153
	04-Oct-2017	-35	PASS						290645		1
	11-Apr-2018	-21	PASS						330348		1
	10-Oct-2018	-23	PASS						374852		1

Released under the Official Information Act 1982

## DETAILED VEHICLE AND INSPECTION REPORT

FOR: PACIFIC HAULAGE LIMITED

Report Printed:

28-Feb-2019

TSL Licence Number: s18(c)(i)

Report run dates between 28/02/2017 and 27/02/2019

PHL06 32900 2014 / KENWORTH T 659  
 GOODS VAN/TRUCK/UTILITY / TRANSPORT LICENSED GOODS  
 PACIFIC HAULAGE LTD

Re Inspection	Inspection Date	Days Presented Since COF Expiry	Result	Fault Code	Component	Fault	Location	Distance Travelled Hubo	Hubodometer Reading	Distance Travelled Odo	Odometer Reading
	10-May-2017		PASS						227618		225359
	13-Nov-2017	-13	PASS						271065		268311
	16-May-2018	-10	PASS						321608		318280
	14-Nov-2018	-12	PASS						374314		370381

Released under the Official Information Act 1982

## DETAILED VEHICLE AND INSPECTION REPORT

FOR: PACIFIC HAULAGE LIMITED

Report Printed:

28-Feb-2019

TSL Licence Number: s18(c)(i)

Report run dates between 28/02/2017 and 27/02/2019

PHL07 32000 2009 / KENWORTH T 408  
 GOODS VAN/TRUCK/UTILITY / TRANSPORT LICENSED GOODS  
 PACIFIC HAULAGE LTD

Re Inspection	Inspection Date	Days Presented Since COF Expiry	Result	Fault Code	Component	Fault	Location	Distance Travelled Hubo	Hubodometer Reading	Distance Travelled Odo	Odometer Reading
	31-May-2017		PASS						68977		789341
	29-Nov-2017	-17	PASS						12015		830539
	30-May-2018	-17	PASS						38408		856959
	21-Nov-2018	-25	PASS						83660		902274

Released under the Official Information Act 1982

**DETAILED VEHICLE AND INSPECTION REPORT**

FOR: PACIFIC HAULAGE LIMITED

Report Printed: 28-Feb-2019

TSL Licence Number: s18(c)(i)

Report run dates between 28/02/2017 and 27/02/2019

PHL08 32900 2016 / KENWORTH T 659  
GOODS VAN/TRUCK/UTILITY / TRANSPORT LICENSED GOODS  
PACIFIC HAULAGE LTD

Re Inspection	Inspection Date	Days Presented Since COF Expiry	Result	Fault Code	Component	Fault	Location	Distance Travelled Hubo	Hubodometer Reading	Distance Travelled Odo	Odometer Reading
	24-May-2017		PASS						90412		94519
	20-Nov-2017	-10	PASS						132938		138771
	28-May-2018	-2	PASS						167889		175108
	28-Nov-2018	-2	PASS						207363		216185

Released under the Official Information Act 1982



**DETAILED VEHICLE AND INSPECTION REPORT**

FOR: PACIFIC HAULAGE LIMITED

Report Printed:

28-Feb-2019

TSL Licence Number: s18(c)(i)

Report run dates between 28/02/2017 and 27/02/2019

PHL09 32900 2014 / KENWORTH T 659  
GOODS VAN/TRUCK/UTILITY / TRANSPORT LICENSED GOODS  
PACIFIC HAULAGE LTD

Re Inspection	Inspection Date	Days Presented Since COF Expiry	Result	Fault Code	Component	Fault	Location	Distance Travelled Hubo	Hubodometer Reading	Distance Travelled Odo	Odometer Reading
	08-Mar-2017		PASS						253912		260783
	18-Sep-2017	-7	PASS						306668		314717
	21-Mar-2018	-4	FAIL	BSM2	SERVICE BRAKE	MATCH	FRONT		343564		352116
*	22-Mar-2018		PASS					8	343572	8	352124
	19-Sep-2018	-6	PASS						385905		395332

Released under the Official Information Act 1982

**DETAILED VEHICLE AND INSPECTION REPORT**

FOR: PACIFIC HAULAGE LIMITED

Report Printed: 28-Feb-2019

TSL Licence Number: s18(c)(i)

Report run dates between 28/02/2017 and 27/02/2019

PHL10 28500 2018 / KENWORTH T 659  
GOODS VAN/TRUCK/UTILITY / TRANSPORT LICENSED GOODS  
PACIFIC HAULAGE LTD

Re Inspection	Inspection Date	Days Presented Since COF Expiry	Result	Fault Code	Component	Fault	Location	Distance Travelled Hubo	Hubodometer Reading	Distance Travelled Odo	Odometer Reading
	03-Aug-2018		PASS						0		584
	07-Jan-2019	-27	PASS						28763		29948

Released under the Official Information Act 1982

**DETAILED VEHICLE AND INSPECTION REPORT**

FOR: PACIFIC HAULAGE LIMITED

Report Printed: 28-Feb-2019

TSL Licence Number: s18(c)(i)

Report run dates between 28/02/2017 and 27/02/2019

PHL13 28500 2017 / KENWORTH T 659  
GOODS VAN/TRUCK/UTILITY / TRANSPORT LICENSED GOODS  
PACIFIC HAULAGE LTD

Re Inspection	Inspection Date	Days Presented Since COF Expiry	Result	Fault Code	Component	Fault	Location	Distance Travelled Hubo	Hubodometer Reading	Distance Travelled Odo	Odometer Reading
	15-Dec-2017		PASS						0		559
	21-May-2018	-25	PASS						39832		41390
	26-Nov-2018	-19	PASS						108406		111036

Released under the Official Information Act 1982

**DETAILED VEHICLE AND INSPECTION REPORT**

FOR: PACIFIC HAULAGE LIMITED

Report Printed:

28-Feb-2019

TSL Licence Number: s18(c)(i)

Report run dates between 28/02/2017 and 27/02/2019

PHL14 32600 2009 / KENWORTH K108  
GOODS VAN/TRUCK/UTILITY / TRANSPORT LICENSED GOODS  
PACIFIC HAULAGE LTD

Re Inspection	Inspection Date	Days Presented Since COF Expiry	Result	Fault Code	Component	Fault	Location	Distance Travelled Hubo	Hubodometer Reading	Distance Travelled Odo	Odometer Reading
	17-May-2017		PASS						284615		367138
	15-Nov-2017	-11	PASS						340332		423008
	23-May-2018	-3	PASS						390977		423008
	30-Oct-2018	74	PASS						402711		423008

Released under the Official Information Act 1982

**DETAILED VEHICLE AND INSPECTION REPORT**

FOR: PACIFIC HAULAGE LIMITED

Report Printed: 28-Feb-2019

TSL Licence Number: s18(c)(i)

Report run dates between 28/02/2017 and 27/02/2019

PHL15 32900 2009 / KENWORTH T 408  
GOODS VAN/TRUCK/UTILITY / TRANSPORT LICENSED GOODS  
PACIFIC HAULAGE LTD

Re Inspection	Inspection Date	Days Presented Since COF Expiry	Result	Fault Code	Component	Fault	Location	Distance Travelled Hubo	Hubodometer Reading	Distance Travelled Odo	Odometer Reading
	23-Aug-2017		PASS						288720		675959
	21-Feb-2018	-8	PASS						335599		1
	22-Aug-2018	-10	PASS						372862		1
	13-Feb-2019	-16	PASS						423630		1

Released under the Official Information Act 1982

**DETAILED VEHICLE AND INSPECTION REPORT**

FOR: PACIFIC HAULAGE LIMITED

Report Printed: 28-Feb-2019

TSL Licence Number: s18(c)(i)

Report run dates between 28/02/2017 and 27/02/2019

PHL16 32000 2011 / KENWORTH K108  
GOODS VAN/TRUCK/UTILITY / TRANSPORT LICENSED GOODS  
PACIFIC HAULAGE LTD

Re Inspection	Inspection Date	Days Presented Since COF Expiry	Result	Fault Code	Component	Fault	Location	Distance Travelled Hubo	Hubodometer Reading	Distance Travelled Odo	Odometer Reading
	19-Jul-2017		PASS						268816		1
	29-Dec-2017	-28	PASS						340024		1
	11-Jul-2018	-15	PASS						383534		1
	27-Dec-2018	-30	PASS						420284		1

Released under the Official Information Act 1982

## DETAILED VEHICLE AND INSPECTION REPORT

FOR: PACIFIC HAULAGE LIMITED

Report Printed: 28-Feb-2019

TSL Licence Number: s18(c)(i)

Report run dates between 28/02/2017 and 27/02/2019

PHL17 28500 2018 / KENWORTH T 659  
 GOODS VAN/TRUCK/UTILITY / TRANSPORT LICENSED GOODS  
 PACIFIC HAULAGE LTD

Re Inspection	Inspection Date	Days Presented Since COF Expiry	Result	Fault Code	Component	Fault	Location	Distance Travelled Hubo	Hubodometer Reading	Distance Travelled Odo	Odometer Reading
	07-Feb-2018		PASS						0		584
	25-Jul-2018	-13	PASS						31972		32880
	04-Jan-2019	-34	PASS						66961		68310

Released under the Official Information Act 1982

**DETAILED VEHICLE AND INSPECTION REPORT**

FOR: PACIFIC HAULAGE LIMITED

Report Printed:

28-Feb-2019

TSL Licence Number: s18(c)(i)

Report run dates between 28/02/2017 and 27/02/2019

PHL18 32900 2010 / KENWORTH T 408  
GOODS VAN/TRUCK/UTILITY / TRANSPORT LICENSED GOODS  
PACIFIC HAULAGE LTD

Re Inspection	Inspection Date	Days Presented Since COF Expiry	Result	Fault Code	Component	Fault	Location	Distance Travelled Hubo	Hubodometer Reading	Distance Travelled Odo	Odometer Reading
	28-Jun-2017		PASS						308574		1
	13-Dec-2017	-23	PASS						342473		1
	08-May-2018	4	PASS						371212		1
	05-Nov-2018	-3	PASS						410258		1

Released under the Official Information Act 1982



**DETAILED VEHICLE AND INSPECTION REPORT**

FOR: PACIFIC HAULAGE LIMITED

Report Printed:

28-Feb-2019

TSL Licence Number: s18(c)(i)

Report run dates between 28/02/2017 and 27/02/2019

PHL19 32000 2011 / KENWORTH K 108  
GOODS VAN/TRUCK/UTILITY / TRANSPORT LICENSED GOODS  
PACIFIC HAULAGE LTD

Re Inspection	Inspection Date	Days Presented Since COF Expiry	Result	Fault Code	Component	Fault	Location	Distance Travelled Hubo	Hubodometer Reading	Distance Travelled Odo	Odometer Reading
	26-Apr-2017		PASS						90467		1
	25-Oct-2017	-5	PASS						132730		1
	30-Apr-2018	0	PASS						170871		1
	31-Oct-2018	0	PASS						204182		1

Released under the Official Information Act 1982

**DETAILED VEHICLE AND INSPECTION REPORT**

FOR: PACIFIC HAULAGE LIMITED

Report Printed:

28-Feb-2019

TSL Licence Number: s18(c)(i)

Report run dates between 28/02/2017 and 27/02/2019

PHL21 32000 2013 / KENWORTH T 659  
GOODS VAN/TRUCK/UTILITY / TRANSPORT LICENSED GOODS  
PACIFIC HAULAGE LTD

Re Inspection	Inspection Date	Days Presented Since COF Expiry	Result	Fault Code	Component	Fault	Location	Distance Travelled Hubo	Hubodometer Reading	Distance Travelled Odo	Odometer Reading
	15-Mar-2017		PASS						229601		338240
	13-Sep-2017	-29	PASS						293722		402107
	14-Mar-2018	-27	PASS						343340		451520
	17-Sep-2018	-23	PASS						391034		498776

Released under the Official Information Act 1982

**DETAILED VEHICLE AND INSPECTION REPORT**

FOR: PACIFIC HAULAGE LIMITED

Report Printed: 28-Feb-2019

TSL Licence Number: s18(c)(i)

Report run dates between 28/02/2017 and 27/02/2019

PHL22 32900 2011 / KENWORTH K 108  
GOODS VAN/TRUCK/UTILITY / TRANSPORT LICENSED GOODS  
PACIFIC HAULAGE LTD

Re Inspection	Inspection Date	Days Presented Since COF Expiry	Result	Fault Code	Component	Fault	Location	Distance Travelled Hubo	Hubodometer Reading	Distance Travelled Odo	Odometer Reading
	12-Jul-2017		FAIL	BVL2	BRAKE VALVES	LEAKS	FRONT		258105		1
	12-Jul-2017		FAIL	CCS3	CROSS MEMBERS	CRACKED	REAR		258105		1
*	13-Jul-2017		PASS					10	258115	0	1
	03-Jan-2018	-23	PASS						297269		646403
	18-Jul-2018	-8	PASS						334677		646403

Released under the Official Information Act 1982

**DETAILED VEHICLE AND INSPECTION REPORT**

FOR: PACIFIC HAULAGE LIMITED

Report Printed:

28-Feb-2019

TSL Licence Number: s18(c)(i)

Report run dates between 28/02/2017 and 27/02/2019

PHL23 32900 2010 / KENWORTH T408  
GOODS VAN/TRUCK/UTILITY / TRANSPORT LICENSED GOODS  
PACIFIC HAULAGE LTD

Re Inspection	Inspection Date	Days Presented Since COF Expiry	Result	Fault Code	Component	Fault	Location	Distance Travelled Hubo	Hubodometer Reading	Distance Travelled Odo	Odometer Reading
	24-Apr-2017		PASS						354403		1
	30-Oct-2017	-22	PASS						401489		1
	23-Apr-2018	-28	PASS						441656		1
	24-Oct-2018	-28	PASS						482393		1

Released under the Official Information Act 1982

**DETAILED VEHICLE AND INSPECTION REPORT**

FOR: PACIFIC HAULAGE LIMITED

Report Printed:

28-Feb-2019

TSL Licence Number: s18(c)(i)

Report run dates between 28/02/2017 and 27/02/2019

PHL25 32000 2017 / KENWORTH T 659  
GOODS VAN/TRUCK/UTILITY / TRANSPORT LICENSED GOODS  
PACIFIC HAULAGE LTD

Re Inspection	Inspection Date	Days Presented Since COF Expiry	Result	Fault Code	Component	Fault	Location	Distance Travelled Hubo	Hubodometer Reading	Distance Travelled Odo	Odometer Reading
	16-Oct-2017		PASS						53636		56431
	27-Apr-2018	-5	PASS						113393		118618
	29-Oct-2018	-4	FAIL	BSI3	SERVICE BRAKE	TO IMPROVE	REAR		161702		168145
*	29-Oct-2018		PASS					9	161711		168154

Released under the Official Information Act 1982

**DETAILED VEHICLE AND INSPECTION REPORT**

FOR: PACIFIC HAULAGE LIMITED

Report Printed: 28-Feb-2019

TSL Licence Number: s18(c)(i)

Report run dates between 28/02/2017 and 27/02/2019

PHL26 32000 2016 / KENWORTH T 659  
GOODS VAN/TRUCK/UTILITY / TRANSPORT LICENSED GOODS  
PACIFIC HAULAGE LTD

Re Inspection	Inspection Date	Days Presented Since COF Expiry	Result	Fault Code	Component	Fault	Location	Distance Travelled Hubo	Hubodometer Reading	Distance Travelled Odo	Odometer Reading
	02-Aug-2017		PASS						97855		113465
	04-Jan-2018	-30	PASS						137027		123672
	01-Aug-2018	0	PASS						188896		142499
	28-Dec-2018	-35	PASS						227632		166044

Released under the Official Information Act 1982

## DETAILED VEHICLE AND INSPECTION REPORT

FOR: PACIFIC HAULAGE LIMITED

Report Printed:

28-Feb-2019

TSL Licence Number: s18(c)(i)

Report run dates between 28/02/2017 and 27/02/2019

PHL27 32000 2016 / KENWORTH T 659  
 GOODS VAN/TRUCK/UTILITY / TRANSPORT LICENSED GOODS  
 PACIFIC HAULAGE LTD

Re Inspection	Inspection Date	Days Presented Since COF Expiry	Result	Fault Code	Component	Fault	Location	Distance Travelled Hubo	Hubodometer Reading	Distance Travelled Odo	Odometer Reading
	03-Apr-2017		PASS						11639		12448
	09-Oct-2017	-10	PASS						73277		75548
	16-Apr-2018	-3	PASS						134524		135496
	15-Oct-2018	-4	PASS						195083		185851

Released under the Official Information Act 1982

**DETAILED VEHICLE AND INSPECTION REPORT**

FOR: PACIFIC HAULAGE LIMITED

Report Printed: 28-Feb-2019

TSL Licence Number: s18(c)(i)

Report run dates between 28/02/2017 and 27/02/2019

PHL28 32000 2017 / KENWORTH T 659  
GOODS VAN/TRUCK/UTILITY / TRANSPORT LICENSED GOODS  
PACIFIC HAULAGE LTD

Re Inspection	Inspection Date	Days Presented Since COF Expiry	Result	Fault Code	Component	Fault	Location	Distance Travelled Hubo	Hubodometer Reading	Distance Travelled Odo	Odometer Reading
	21-Jul-2017		PASS						31239		35419
	20-Dec-2017	-50	PASS						72787		77215
	04-Jul-2018	-14	PASS						117608		122391
	17-Dec-2018	-32	PASS						165943		169407

Released under the Official Information Act 1982



**DETAILED VEHICLE AND INSPECTION REPORT**

FOR: PACIFIC HAULAGE LIMITED

Report Printed: 28-Feb-2019

TSL Licence Number: s18(c)(i)

Report run dates between 28/02/2017 and 27/02/2019

PHL29 32000 2010 / KENWORTH K108  
GOODS VAN/TRUCK/UTILITY / TRANSPORT LICENSED GOODS  
PACIFIC HAULAGE LTD

Re Inspection	Inspection Date	Days Presented Since COF Expiry	Result	Fault Code	Component	Fault	Location	Distance Travelled Hubo	Hubodometer Reading	Distance Travelled Odo	Odometer Reading
	14-Jun-2017		PASS						41911		1
	11-Dec-2017	-10	PASS						87806		1
	20-Jun-2018	-1	PASS						124792		750591
	19-Dec-2018	-2	PASS						161814		1

Released under the Official Information Act 1982

**DETAILED VEHICLE AND INSPECTION REPORT**

FOR: PACIFIC HAULAGE LIMITED

Report Printed: 28-Feb-2019

TSL Licence Number: s18(c)(i)

Report run dates between 28/02/2017 and 27/02/2019

PHL20 32900 2012 / KENWORTH K108  
GOODS VAN/TRUCK/UTILITY / TRANSPORT LICENSED GOODS  
PACIFIC HAULAGE LTD

Re Inspection	Inspection Date	Days Presented Since COF Expiry	Result	Fault Code	Component	Fault	Location	Distance Travelled Hubo	Hubodometer Reading	Distance Travelled Odo	Odometer Reading
	06-Mar-2017		PASS						243393		1
	06-Sep-2017	0	PASS						298202		1
	07-Mar-2018	0	PASS						331689		1
	05-Sep-2018	-2	PASS						377129		1
	27-Feb-2019	-8	PASS						405707		1

Released under the Official Information Act 1982

**DETAILED VEHICLE AND INSPECTION REPORT**

FOR: PACIFIC HAULAGE LIMITED

Report Printed: 28-Feb-2019

TSL Licence Number: s18(c)(i)

Report run dates between 28/02/2017 and 27/02/2019

PHL30 32900 2011 / KENWORTH K 108  
GOODS VAN/TRUCK/UTILITY / TRANSPORT LICENSED GOODS  
PACIFIC HAULAGE LTD

Re Inspection	Inspection Date	Days Presented Since COF Expiry	Result	Fault Code	Component	Fault	Location	Distance Travelled Hubo	Hubodometer Reading	Distance Travelled Odo	Odometer Reading
	01-Mar-2017		PASS						240774		1
	30-Aug-2017	-5	PASS						284335		1
	28-Feb-2018	-4	PASS						325395		1
	29-Aug-2018	-6	PASS						357606		1
	20-Feb-2019	-12	PASS						383438		1

Released under the Official Information Act 1982

**DETAILED VEHICLE AND INSPECTION REPORT**

FOR: PACIFIC HAULAGE LIMITED

Report Printed: 28-Feb-2019

TSL Licence Number: s18(c)(i)

Report run dates between 28/02/2017 and 27/02/2019

PHL31 32900 2013 / KENWORTH T 659  
GOODS VAN/TRUCK/UTILITY / TRANSPORT LICENSED GOODS  
PACIFIC HAULAGE LTD

Re Inspection	Inspection Date	Days Presented Since COF Expiry	Result	Fault Code	Component	Fault	Location	Distance Travelled Hubo	Hubodometer Reading	Distance Travelled Odo	Odometer Reading
	07-Jun-2017		PASS						306559		393410
	06-Dec-2017	-12	PASS						353646		440918
	13-Jun-2018	-5	PASS						397711		485471
	10-Dec-2018	-8	PASS						443067		531295

Released under the Official Information Act 1982

**DETAILED VEHICLE AND INSPECTION REPORT**

FOR: PACIFIC HAULAGE LIMITED

Report Printed: 28-Feb-2019

TSL Licence Number: s18(c)(i)

Report run dates between 28/02/2017 and 27/02/2019

PHL32 32900 2013 / KENWORTH T 659  
 GOODS VAN/TRUCK/UTILITY / TRANSPORT LICENSED GOODS  
 PACIFIC HAULAGE LTD

Re Inspection	Inspection Date	Days Presented Since COF Expiry	Result	Fault Code	Component	Fault	Location	Distance Travelled Hubo	Hubodometer Reading	Distance Travelled Odo	Odometer Reading
	09-Aug-2017		PASS						357744		442440
	07-Feb-2018	-19	PASS						390977		476159
	08-Aug-2018	-18	PASS						432973		519014
	04-Feb-2019	-22	PASS						472009		559008

Released under the Official Information Act 1982

**DETAILED VEHICLE AND INSPECTION REPORT**

FOR: PACIFIC HAULAGE LIMITED

Report Printed:

28-Feb-2019

TSL Licence Number: s18(c)(i)

Report run dates between 28/02/2017 and 27/02/2019

PHL33 32900 2013 / KENWORTH T 659  
GOODS VAN/TRUCK/UTILITY / TRANSPORT LICENSED GOODS  
PACIFIC HAULAGE LTD

Re Inspection	Inspection Date	Days Presented Since COF Expiry	Result	Fault Code	Component	Fault	Location	Distance Travelled Hubo	Hubodometer Reading	Distance Travelled Odo	Odometer Reading
	22-Mar-2017		PASS						281924		333868
	20-Sep-2017	-13	PASS						338827		391395
	26-Mar-2018	-8	PASS						43862		438942
	26-Sep-2018	-7	PASS						84205		479781

Released under the Official Information Act 1982

**DETAILED VEHICLE AND INSPECTION REPORT**

FOR: PACIFIC HAULAGE LIMITED

Report Printed: 28-Feb-2019

TSL Licence Number: s18(c)(i)

Report run dates between 28/02/2017 and 27/02/2019

PHL34 32900 2014 / KENWORTH T 659  
GOODS VAN/TRUCK/UTILITY / TRANSPORT LICENSED GOODS  
PACIFIC HAULAGE LTD

Re Inspection	Inspection Date	Days Presented Since COF Expiry	Result	Fault Code	Component	Fault	Location	Distance Travelled Hubo	Hubodometer Reading	Distance Travelled Odo	Odometer Reading
	16-Aug-2017		FAIL	BSM3	SERVICE BRAKE	MATCH	REAR		333333		352833
*	17-Aug-2017		PASS					1	333334	9	352842
	14-Feb-2018	-13	PASS						375340		394765
	15-Aug-2018	-12	PASS						430961		450250
	11-Feb-2019	-16	PASS						470711		489998

Released under the Official Information Act 1982

**DETAILED VEHICLE AND INSPECTION REPORT**

FOR: PACIFIC HAULAGE LIMITED

Report Printed:

28-Feb-2019

TSL Licence Number: s18(c)(i)

Report run dates between 28/02/2017 and 27/02/2019

PHL35 32900 2014 / KENWORTH T 659  
GOODS VAN/TRUCK/UTILITY / TRANSPORT LICENSED GOODS  
PACIFIC HAULAGE LTD

Re Inspection	Inspection Date	Days Presented Since COF Expiry	Result	Fault Code	Component	Fault	Location	Distance Travelled Hubo	Hubodometer Reading	Distance Travelled Odo	Odometer Reading
	08-May-2017		PASS						216317		216791
	08-Nov-2017	-9	PASS						7268		257320
	02-May-2018	-15	PASS						43033		293227
	07-Nov-2018	-10	PASS						91196		340702

Released under the Official Information Act 1982



**DETAILED VEHICLE AND INSPECTION REPORT**

FOR: PACIFIC HAULAGE LIMITED

Report Printed: 28-Feb-2019

TSL Licence Number: s18(c)(i)

Report run dates between 28/02/2017 and 27/02/2019

PHL36 32000 2017 / KENWORTH T 659  
GOODS VAN/TRUCK/UTILITY / TRANSPORT LICENSED GOODS  
PACIFIC HAULAGE LTD

Re Inspection	Inspection Date	Days Presented Since COF Expiry	Result	Fault Code	Component	Fault	Location	Distance Travelled Hubo	Hubodometer Reading	Distance Travelled Odo	Odometer Reading
	25-Sep-2017		PASS						43394		48055
	14-Mar-2018	54	PASS						72321		77149
	12-Sep-2018	-2	PASS						121454		127094

Released under the Official Information Act 1982

**DETAILED VEHICLE AND INSPECTION REPORT**

FOR: PACIFIC HAULAGE LIMITED

Report Printed: 28-Feb-2019

TSL Licence Number: s18(c)(i)

Report run dates between 28/02/2017 and 27/02/2019

PHL37 32000 2017 / KENWORTH T 659  
GOODS VAN/TRUCK/UTILITY / TRANSPORT LICENSED GOODS  
PACIFIC HAULAGE LTD

Re Inspection	Inspection Date	Days Presented Since COF Expiry	Result	Fault Code	Component	Fault	Location	Distance Travelled Hubo	Hubodometer Reading	Distance Travelled Odo	Odometer Reading
	20-Jul-2017		PASS						0		644
	08-Dec-2017	-43	FAIL	BSM2	SERVICE BRAKE	MATCH	FRONT		34953		35592
*	08-Dec-2017		PASS					9	34962	9	35601
	27-Jun-2018	-9	PASS						65554		65903
	03-Dec-2018	-34	PASS						107662		108093

Released under the Official Information Act 1982

**DETAILED VEHICLE AND INSPECTION REPORT**

FOR: PACIFIC HAULAGE LIMITED

Report Printed:

28-Feb-2019

TSL Licence Number: s18(c)(i)

Report run dates between 28/02/2017 and 27/02/2019

PHL38 32000 2017 / KENWORTH T 659  
GOODS VAN/TRUCK/UTILITY / TRANSPORT LICENSED GOODS  
PACIFIC HAULAGE LTD

Re Inspection	Inspection Date	Days Presented Since COF Expiry	Result	Fault Code	Component	Fault	Location	Distance Travelled Hubo	Hubodometer Reading	Distance Travelled Odo	Odometer Reading
	22-Nov-2017		PASS						51683		52497
	09-May-2018	-13	PASS						103055		104389
	19-Nov-2018	-3	PASS						167824		169817

Released under the Official Information Act 1982

**DETAILED VEHICLE AND INSPECTION REPORT**

FOR: PACIFIC HAULAGE LIMITED

Report Printed: 28-Feb-2019

TSL Licence Number: s18(c)(i)

Report run dates between 28/02/2017 and 27/02/2019

PHL39 28500 2017 / KENWORTH T 659  
GOODS VAN/TRUCK/UTILITY / TRANSPORT LICENSED GOODS  
PACIFIC HAULAGE LTD

Re Inspection	Inspection Date	Days Presented Since COF Expiry	Result	Fault Code	Component	Fault	Location	Distance Travelled Hubo	Hubodometer Reading	Distance Travelled Odo	Odometer Reading
	29-Sep-2017		PASS						0		569
	12-Mar-2018	-17	PASS						45731		46453
	10-Sep-2018	-19	PASS						98727		99635

Released under the Official Information Act 1982

**DETAILED VEHICLE AND INSPECTION REPORT**

FOR: PACIFIC HAULAGE LIMITED

Report Printed: 28-Feb-2019

TSL Licence Number: s18(c)(i)

Report run dates between 28/02/2017 and 27/02/2019

PHL40 28500 2017 / KENWORTH T 659  
GOODS VAN/TRUCK/UTILITY / TRANSPORT LICENSED GOODS  
PACIFIC HAULAGE LTD

Re Inspection	Inspection Date	Days Presented Since COF Expiry	Result	Fault Code	Component	Fault	Location	Distance Travelled Hubo	Hubodometer Reading	Distance Travelled Odo	Odometer Reading
	02-Nov-2017		PASS						0		230
	05-Mar-2018	-58	PASS						31250		31982
	24-Sep-2018	-9	PASS						829864		83982

Released under the Official Information Act 1982

**DETAILED VEHICLE AND INSPECTION REPORT**

FOR: PACIFIC HAULAGE LIMITED

Report Printed:

28-Feb-2019

TSL Licence Number: s18(c)(i)

Report run dates between 28/02/2017 and 27/02/2019

PHL41 32000 2018 / KENWORTH T 659 8X4  
GOODS VAN/TRUCK/UTILITY / TRANSPORT LICENSED GOODS  
PACIFIC HAULAGE LTD

Re Inspection	Inspection Date	Days Presented Since COF Expiry	Result	Fault Code	Component	Fault	Location	Distance Travelled Hubo	Hubodometer Reading	Distance Travelled Odo	Odometer Reading
	17-May-2018		PASS						0		569
	12-Nov-2018	-5	PASS						34204		34359

Released under the Official Information Act 1982

**DETAILED VEHICLE AND INSPECTION REPORT**

FOR: PACIFIC HAULAGE LIMITED

Report Printed: 28-Feb-2019

TSL Licence Number: s18(c)(i)

Report run dates between 28/02/2017 and 27/02/2019

PHL42 28500 2018 / KENWORTH T 659  
GOODS VAN/TRUCK/UTILITY / TRANSPORT LICENSED GOODS  
PACIFIC HAULAGE LTD

Re Inspection	Inspection Date	Days Presented Since COF Expiry	Result	Fault Code	Component	Fault	Location	Distance Travelled Hubo	Hubodometer Reading	Distance Travelled Odo	Odometer Reading
	13-Jul-2018		PASS						0		208
	12-Dec-2018	-32	PASS						21931		45123

Released under the Official Information Act 1982

**DETAILED VEHICLE AND INSPECTION REPORT**

FOR: PACIFIC HAULAGE LIMITED

Report Printed: 28-Feb-2019

TSL Licence Number: s18(c)(i)

Report run dates between 28/02/2017 and 27/02/2019

PHL43 28500 2018 / KENWORTH T 659  
GOODS VAN/TRUCK/UTILITY / TRANSPORT LICENSED GOODS  
PACIFIC HAULAGE LTD

Re Inspection	Inspection Date	Days Presented Since COF Expiry	Result	Fault Code	Component	Fault	Location	Distance Travelled Hubo	Hubodometer Reading	Distance Travelled Odo	Odometer Reading
	24-Jul-2018		PASS						0		600
	03-Jan-2019	-21	PASS						47728		48742

Released under the Official Information Act 1982



**DETAILED VEHICLE AND INSPECTION REPORT**

FOR: PACIFIC HAULAGE LIMITED

Report Printed:

28-Feb-2019

TSL Licence Number: s18(c)(i)

Report run dates between 28/02/2017 and 27/02/2019

Q884L 30000 2010 / KRAFT 404  
TRAILER/CARAVAN / TRANSPORT LICENSED GOODS  
PACIFIC HAULAGE LTD

Re Inspection	Inspection Date	Days Presented Since COF Expiry	Result	Fault Code	Component	Fault	Location	Distance Travelled Hubo	Hubodometer Reading	Distance Travelled Odo	Odometer Reading
	24-Apr-2017		PASS						158168		1
	30-Oct-2017	0	PASS						184138		1
	23-Apr-2018	-7	PASS						203976		1
	24-Oct-2018	-6	PASS						223895		1

Released under the Official Information Act 1982

**DETAILED VEHICLE AND INSPECTION REPORT**

FOR: PACIFIC HAULAGE LIMITED

Report Printed:

28-Feb-2019

TSL Licence Number: s18(c)(i)

Report run dates between 28/02/2017 and 27/02/2019

R177T 30000 2011 / KRAFT 404  
TRAILER/CARAVAN / TRANSPORT LICENSED GOODS  
PACIFIC HAULAGE LTD

Re Inspection	Inspection Date	Days Presented Since COF Expiry	Result	Fault Code	Component	Fault	Location	Distance Travelled Hubo	Hubodometer Reading	Distance Travelled Odo	Odometer Reading
	05-Apr-2017		PASS						118011		1
	02-Oct-2017	-5	FAIL	BSM1	SERVICE BRAKE	MATCH	ALL		142092		1
*	02-Oct-2017		PASS					6	142098	0	1
	04-Apr-2018	-3	FAIL	CCS8	CROSS MEMBERS	CRACKED	LEFT REAR		15433		1
*	05-Apr-2018		PASS					10	15443	0	1
	08-Oct-2018	0	PASS						179894		1

Released under the Official Information Act 1982

## DETAILED VEHICLE AND INSPECTION REPORT

FOR: PACIFIC HAULAGE LIMITED

Report Printed:

28-Feb-2019

TSL Licence Number: s18(c)(i)

Report run dates between 28/02/2017 and 27/02/2019

R179F      30000      2011 / KRAFT 404  
 TRAILER/CARAVAN / TRANSPORT LICENSED GOODS  
 PACIFIC HAULAGE LTD

Re Inspection	Inspection Date	Days Presented Since COF Expiry	Result	Fault Code	Component	Fault	Location	Distance Travelled Hubo	Hubodometer Reading	Distance Travelled Odo	Odometer Reading
	28-Jun-2017		PASS						134564		0
	13-Dec-2017	-23	PASS						151148		0
	24-May-2018	20	PASS						165310		0
	05-Nov-2018	-19	PASS						185261		0

Released under the Official Information Act 1982

### DETAILED VEHICLE AND INSPECTION REPORT

FOR: PACIFIC HAULAGE LIMITED

Report Printed:

28-Feb-2019

TSL Licence Number: s18(c)(i)

Report run dates between 28/02/2017 and 27/02/2019

R443P 30000 2011 / KRAFT 404  
TRAILER/CARAVAN / TRANSPORT LICENSED GOODS  
PACIFIC HAULAGE LTD

Re Inspection	Inspection Date	Days Presented Since COF Expiry	Result	Fault Code	Component	Fault	Location	Distance Travelled Hubo	Hubodometer Reading	Distance Travelled Odo	Odometer Reading
	01-Mar-2017		PASS						143907		1
	30-Aug-2017	-3	PASS						165387		1
	28-Feb-2018	-2	PASS						185703		1
	29-Aug-2018	-4	PASS						201254		1
	20-Feb-2019	-10	PASS						214633		1

Released under the Official Information Act 1982

**DETAILED VEHICLE AND INSPECTION REPORT**

FOR: PACIFIC HAULAGE LIMITED

Report Printed:

28-Feb-2019

TSL Licence Number: s18(c)(i)

Report run dates between 28/02/2017 and 27/02/2019

R462K 30000 2011 / KRAFT 404  
TRAILER/CARAVAN / TRANSPORT LICENSED GOODS  
PACIFIC HAULAGE LTD

Re Inspection	Inspection Date	Days Presented Since COF Expiry	Result	Fault Code	Component	Fault	Location	Distance Travelled Hubo	Hubodometer Reading	Distance Travelled Odo	Odometer Reading
	12-Jul-2017		PASS						65552		1
	03-Jan-2018	-23	PASS						84736		1
	18-Jul-2018	-8	PASS						102954		1
	09-Jan-2019	-17	PASS						104053		1

Released under the Official Information Act 1982

**DETAILED VEHICLE AND INSPECTION REPORT**

FOR: PACIFIC HAULAGE LIMITED

Report Printed:

28-Feb-2019

TSL Licence Number: s18(c)(i)

Report run dates between 28/02/2017 and 27/02/2019

S25E 30000 2011 / KRAFT 404  
TRAILER/CARAVAN / TRANSPORT LICENSED GOODS  
PACIFIC HAULAGE LTD

Re Inspection	Inspection Date	Days Presented Since COF Expiry	Result	Fault Code	Component	Fault	Location	Distance Travelled Hubo	Hubodometer Reading	Distance Travelled Odo	Odometer Reading
	19-Jul-2017		PASS						21203		1
	29-Dec-2017	-28	PASS						37967		1
	11-Jul-2018	-15	PASS						59615		1
	27-Dec-2018	-30	PASS						78642		1

Released under the Official Information Act 1982

### DETAILED VEHICLE AND INSPECTION REPORT

FOR: PACIFIC HAULAGE LIMITED

Report Printed: 28-Feb-2019

TSL Licence Number: s18(c)(i)

Report run dates between 28/02/2017 and 27/02/2019

S532N 30000 2011 / KRAFT 404  
TRAILER/CARAVAN / TRANSPORT LICENSED GOODS  
PACIFIC HAULAGE LTD

Re Inspection	Inspection Date	Days Presented Since COF Expiry	Result	Fault Code	Component	Fault	Location	Distance Travelled Hubo	Hubodometer Reading	Distance Travelled Odo	Odometer Reading
	29-May-2017		PASS						198967		1
	04-Dec-2017	-16	PASS						6845		1
	06-Jun-2018	-14	PASS						24746		1
	05-Dec-2018	-15	PASS						42599		1

Released under the Official Information Act 1982

**DETAILED VEHICLE AND INSPECTION REPORT**

FOR: PACIFIC HAULAGE LIMITED

Report Printed: 28-Feb-2019

TSL Licence Number: s18(c)(i)

Report run dates between 28/02/2017 and 27/02/2019

S597H 30000 2011 / KRAFT 404  
TRAILER/CARAVAN / TRANSPORT LICENSED GOODS  
PACIFIC HAULAGE LTD

Re Inspection	Inspection Date	Days Presented Since COF Expiry	Result	Fault Code	Component	Fault	Location	Distance Travelled Hubo	Hubodometer Reading	Distance Travelled Odo	Odometer Reading
	26-Apr-2017		PASS						267527		1
	25-Oct-2017	-5	PASS						288343		1
	30-Apr-2018	0	PASS						307202		1
	31-Oct-2018	0	PASS						323738		1

Released under the Official Information Act 1982



## DETAILED VEHICLE AND INSPECTION REPORT

FOR: PACIFIC HAULAGE LIMITED

Report Printed:

28-Feb-2019

TSL Licence Number: s18(c)(i)

Report run dates between 28/02/2017 and 27/02/2019

T672A      30000      2012 / KRAFT 400  
 TRAILER/CARAVAN / TRANSPORT LICENSED GOODS  
 PACIFIC HAULAGE LTD

Re Inspection	Inspection Date	Days Presented Since COF Expiry	Result	Fault Code	Component	Fault	Location	Distance Travelled Hubo	Hubodometer Reading	Distance Travelled Odo	Odometer Reading
	08-May-2017		PASS						216584		1
	08-Nov-2017	0	PASS						236181		1
	02-May-2018	-6	PASS						1389		1
	07-Nov-2018	-1	PASS						24586		1

Released under the Official Information Act 1982

**DETAILED VEHICLE AND INSPECTION REPORT**

FOR: PACIFIC HAULAGE LIMITED

Report Printed:

28-Feb-2019

TSL Licence Number: s18(c)(i)

Report run dates between 28/02/2017 and 27/02/2019

T674A 30000 2012 / KRAFT 404  
TRAILER/CARAVAN / TRANSPORT LICENSED GOODS  
PACIFIC HAULAGE LTD

Re Inspection	Inspection Date	Days Presented Since COF Expiry	Result	Fault Code	Component	Fault	Location	Distance Travelled Hubo	Hubodometer Reading	Distance Travelled Odo	Odometer Reading
	06-Mar-2017		PASS						9047		1
	06-Sep-2017	-1	PASS						35630		1
	07-Mar-2018	0	PASS						51820		1
	05-Sep-2018	-2	PASS						74017		1
	27-Feb-2019	-8	PASS						87919		1

Released under the Official Information Act 1982

**DETAILED VEHICLE AND INSPECTION REPORT**

FOR: PACIFIC HAULAGE LIMITED

Report Printed: 28-Feb-2019

TSL Licence Number: s18(c)(i)

Report run dates between 28/02/2017 and 27/02/2019

U789M 30000 2013 / KRAFT 404  
TRAILER/CARAVAN / TRANSPORT LICENSED GOODS  
PACIFIC HAULAGE LTD

Re Inspection	Inspection Date	Days Presented Since COF Expiry	Result	Fault Code	Component	Fault	Location	Distance Travelled Hubo	Hubodometer Reading	Distance Travelled Odo	Odometer Reading
	24-May-2017		PASS						76427		1
	14-Dec-2017	-7	PASS						194		1
	20-Jun-2018	-1	PASS						6670		1
	19-Dec-2018	-2	PASS						25717		1

Released under the Official Information Act 1982

**DETAILED VEHICLE AND INSPECTION REPORT**

FOR: PACIFIC HAULAGE LIMITED

Report Printed:

28-Feb-2019

TSL Licence Number: s18(c)(i)

Report run dates between 28/02/2017 and 27/02/2019

U800M 34000 2013 / KRAFT 404  
TRAILER/CARAVAN / TRANSPORT LICENSED GOODS  
PACIFIC HAULAGE LTD

Re Inspection	Inspection Date	Days Presented Since COF Expiry	Result	Fault Code	Component	Fault	Location	Distance Travelled Hubo	Hubodometer Reading	Distance Travelled Odo	Odometer Reading
	15-Mar-2017		PASS						174844		1
	13-Sep-2017	-4	PASS						210694		1
	14-Mar-2018	-3	PASS						10248		1
	17-Sep-2018	0	PASS						36420		1

Released under the Official Information Act 1982

**DETAILED VEHICLE AND INSPECTION REPORT**

FOR: PACIFIC HAULAGE LIMITED

Report Printed: 28-Feb-2019

TSL Licence Number: s18(c)(i)

Report run dates between 28/02/2017 and 27/02/2019

W198L 30000 2013 / KRAFT 404  
TRAILER/CARAVAN / TRANSPORT LICENSED GOODS  
PACIFIC HAULAGE LTD

Re Inspection	Inspection Date	Days Presented Since COF Expiry	Result	Fault Code	Component	Fault	Location	Distance Travelled Hubo	Hubodometer Reading	Distance Travelled Odo	Odometer Reading
	09-Aug-2017		PASS						8581		1
	07-Feb-2018	-14	PASS						24571		1
	08-Aug-2018	-13	PASS						44953		1
	04-Feb-2019	-17	PASS						65687		1

Released under the Official Information Act 1982

**DETAILED VEHICLE AND INSPECTION REPORT**

FOR: PACIFIC HAULAGE LIMITED

Report Printed: 28-Feb-2019

TSL Licence Number: s18(c)(i)

Report run dates between 28/02/2017 and 27/02/2019

W730M 30000 2013 / KRAFT 404  
TRAILER/CARAVAN / TRANSPORT LICENSED GOODS  
PACIFIC HAULAGE LTD

Re Inspection	Inspection Date	Days Presented Since COF Expiry	Result	Fault Code	Component	Fault	Location	Distance Travelled Hubo	Hubodometer Reading	Distance Travelled Odo	Odometer Reading
	22-Mar-2017		FAIL	BVL6	BRAKE VALVES	LEAKS	LEFT FRONT		160714		1
*	22-Mar-2017		PASS					9	160723	0	1
	20-Sep-2017	-5	PASS						188482		1
	26-Mar-2018	0	PASS						212341		1
	26-Sep-2018	0	PASS						232390		1

Released under the Official Information Act 1982

**DETAILED VEHICLE AND INSPECTION REPORT**

FOR: PACIFIC HAULAGE LIMITED

Report Printed: 28-Feb-2019

TSL Licence Number: s18(c)(i)

Report run dates between 28/02/2017 and 27/02/2019

W970G 30000 2013 / KRAFT 404  
TRAILER/CARAVAN / TRANSPORT LICENSED GOODS  
PACIFIC HAULAGE LTD

Re Inspection	Inspection Date	Days Presented Since COF Expiry	Result	Fault Code	Component	Fault	Location	Distance Travelled Hubo	Hubodometer Reading	Distance Travelled Odo	Odometer Reading
	07-Jun-2017		FAIL	AWY1	WARNNG DEV-BRAKES	TO COMPLY	ALL		194866		1
	07-Jun-2017		FAIL	BSI1	SERVICE BRAKE	TO IMPROVE	ALL		194866		1
*	08-Jun-2017		PASS					9	194875	0	1
	06-Dec-2017	-12	PASS						218460		1
	13-Jun-2018	-5	PASS						240857		1
	10-Dec-2018	-8	PASS						263895		1

Released under the Official Information Act 1982

**DETAILED VEHICLE AND INSPECTION REPORT**

FOR: PACIFIC HAULAGE LIMITED

Report Printed: 28-Feb-2019

TSL Licence Number: s18(c)(i)

Report run dates between 28/02/2017 and 27/02/2019

Y951K 30000 2014 / KRAFT 404  
TRAILER/CARAVAN / TRANSPORT LICENSED GOODS  
PACIFIC HAULAGE LTD

Re Inspection	Inspection Date	Days Presented Since COF Expiry	Result	Fault Code	Component	Fault	Location	Distance Travelled Hubo	Hubodometer Reading	Distance Travelled Odo	Odometer Reading
	16-Aug-2017		FAIL	EAS3	STRUCTURE	CRACKED	REAR		36232		1
	16-Aug-2017		FAIL	UWY3	WHEEL BEARINGS	TO COMPLY	REAR		36232		1
*	17-Aug-2017		PASS					0	36232	-1	0
	14-Feb-2018	-14	PASS						57643		1
	15-Aug-2018	-13	PASS						84940		1
	11-Feb-2019	-17	PASS						105277		1

Released under the Official Information Act 1982



**DETAILED VEHICLE AND INSPECTION REPORT**

FOR: PACIFIC HAULAGE LIMITED

Report Printed:

28-Feb-2019

TSL Licence Number: s18(c)(i)

Report run dates between 28/02/2017 and 27/02/2019

Z505Y 34000 2014 / KRAFT 404 5A  
TRAILER/CARAVAN / TRANSPORT LICENSED GOODS  
PACIFIC HAULAGE LTD

Re Inspection	Inspection Date	Days Presented Since COF Expiry	Result	Fault Code	Component	Fault	Location	Distance Travelled Hubo	Hubodometer Reading	Distance Travelled Odo	Odometer Reading
	10-May-2017		PASS						90222		1
	13-Nov-2017	-8	FAIL	BSM3	SERVICE BRAKE	MATCH	REAR		113402		1
*	13-Nov-2017		PASS					89	113491	0	1
	16-May-2018	-5	PASS						137667		1
	14-Nov-2018	-7	PASS						163113		1

Released under the Official Information Act 1982

DETAILED VEHICLE AND INSPECTION REPORT

FOR: PACIFIC HAULAGE LIMITED

Report Printed:

28-Feb-2019

TSL Licence Number: s18(c)(i)

Report run dates between 28/02/2017 and 27/02/2019

Z745L 34000 2014 / KRAFT 404 5A  
TRAILER/CARAVAN / TRANSPORT LICENSED GOODS  
PACIFIC HAULAGE LTD

Re Inspection	Inspection Date	Days Presented Since COF Expiry	Result	Fault Code	Component	Fault	Location	Distance Travelled Hubo	Hubodometer Reading	Distance Travelled Odo	Odometer Reading
	08-Mar-2017		PASS						31895		1
	18-Sep-2017	-6	PASS						58683		1
	21-Mar-2018	-3	FAIL	BWL3	WHEEL CYL & CHAMB	LEAKS	REAR		77725		1
*	22-Mar-2018		PASS					5	77730	0	1
	19-Sep-2018	-5	PASS						99660		1

Released under the Official Information Act 1982

**DETAILED VEHICLE AND INSPECTION REPORT**

FOR: PACIFIC HAULAGE LIMITED

Report Printed:

28-Feb-2019

TSL Licence Number: s18(c)(i)

Report run dates between 28/02/2017 and 27/02/2019

Z760L 34000 2014 / KRAFT 404 5A  
TRAILER/CARAVAN / TRANSPORT LICENSED GOODS  
PACIFIC HAULAGE LTD

Re Inspection	Inspection Date	Days Presented Since COF Expiry	Result	Fault Code	Component	Fault	Location	Distance Travelled Hubo	Hubodometer Reading	Distance Travelled Odo	Odometer Reading
	12-Apr-2017		PASS						102370		1
	11-Oct-2017	-12	PASS						125865		1
	18-Apr-2018	-5	PASS						3174		1
	17-Oct-2018	-6	PASS						33955		1

Released under the Official Information Act 1982

Average Number of Faults Identified on all Failed Inspections

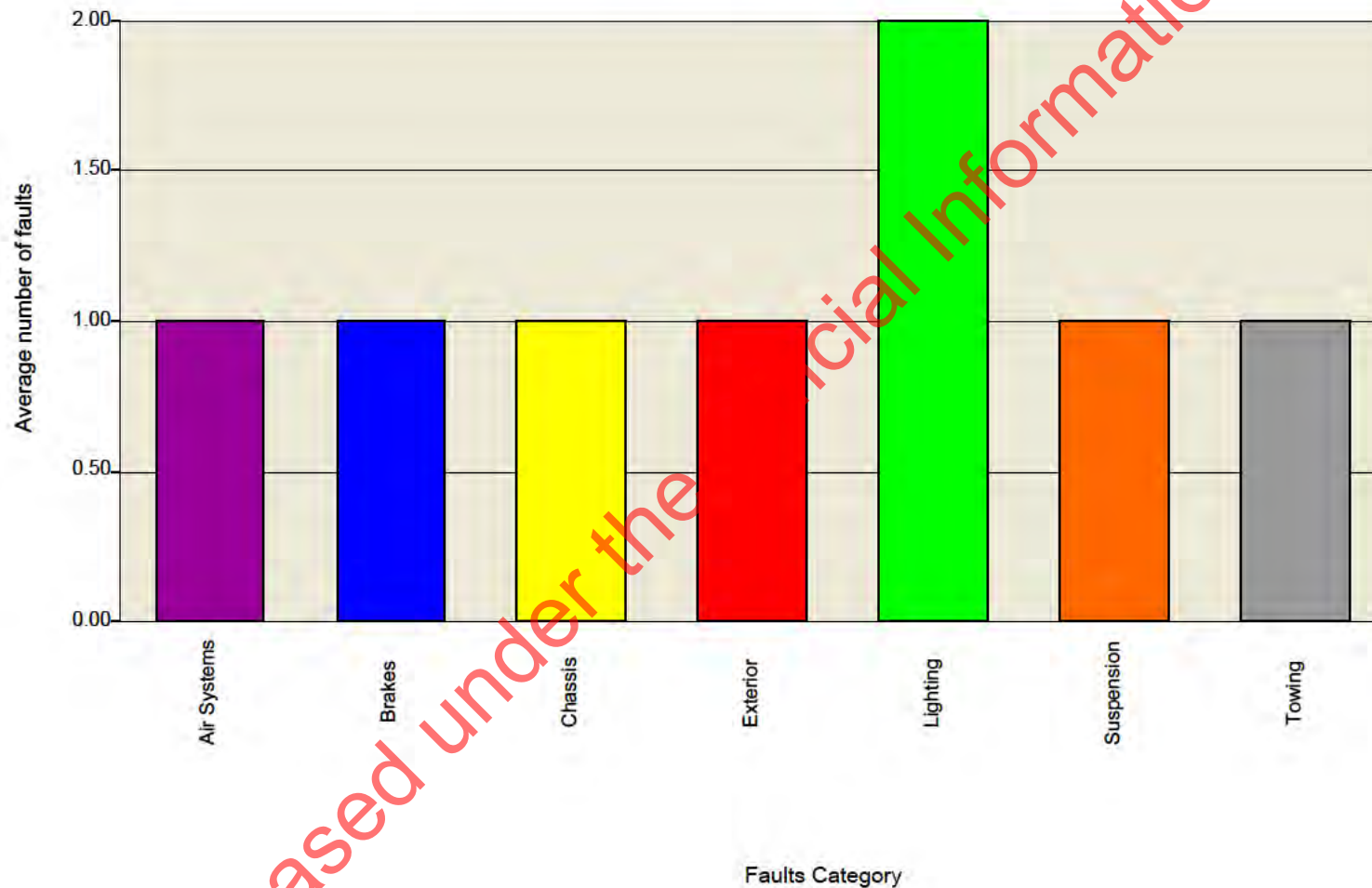

Released under the Official Information Act 1982

PASS RATE ON 1ST COF INSPECTION

PASS  
321 (94%)

Percentage Pass on  
First Inspection

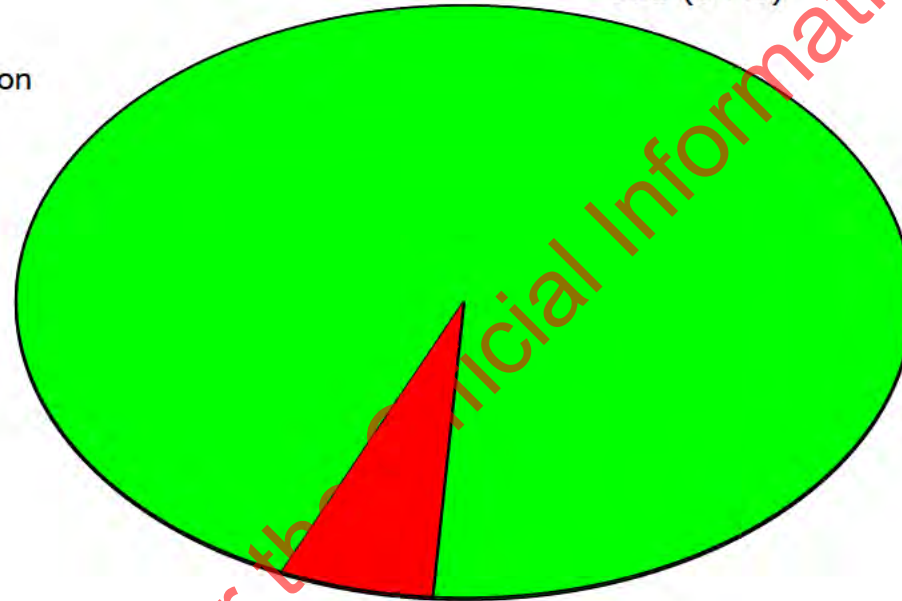

Percentage Fail on  
First Inspection  
FAIL  
19 (6%)

Released under the Official Information Act 1982

Frequency of Faults Identified on all Initial COF Inspections

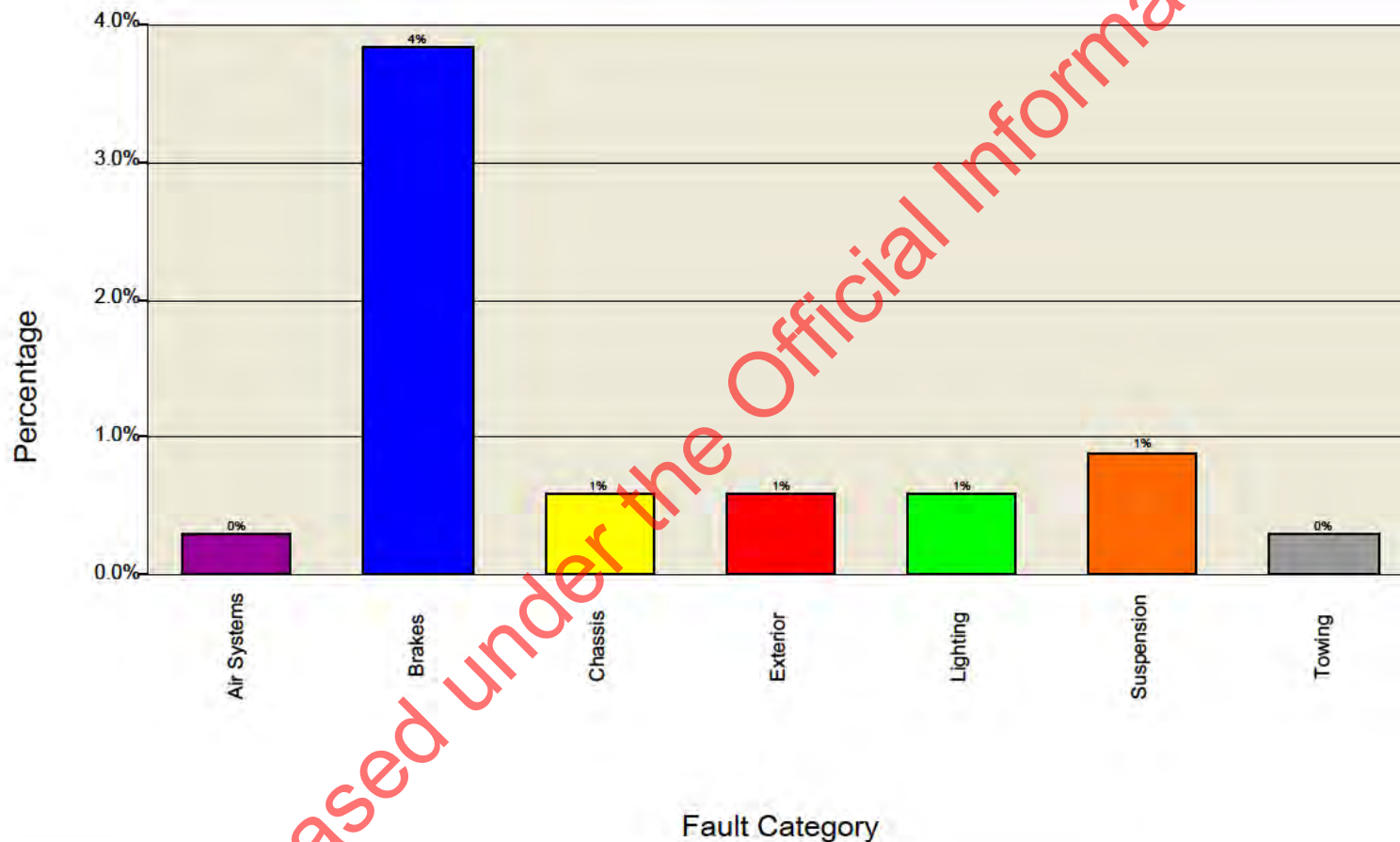

Released under the Official Information Act 1982

Occurrence of faults as a percentage of failed COF inspections

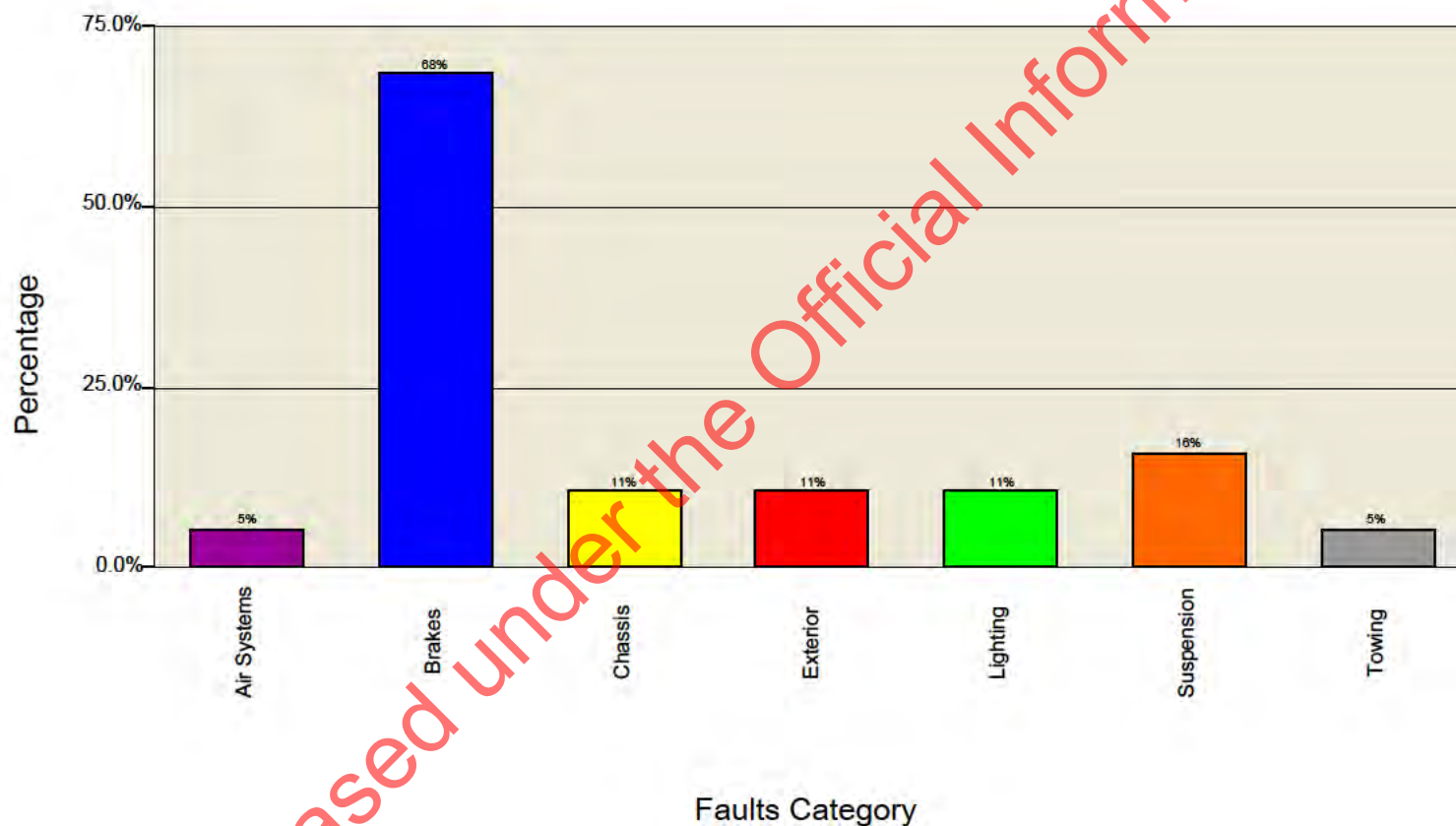

Released under the Official Information Act 1982

FOR: PACIFIC HAULAGE LIMITED

TSL Licence Number: §18(c)

Report run dates between 28/02/2017 and 27/02/2019

Average Age of all Vehicles: 6.66

Count of Vehicles Inspected: 97

Average Age of Vehicle by Vehicle Type

GOODS VAN/TRUCK/UTILITY 6.57

TRAILER/CARAVAN 6.75

Plate	Inspection Location	Inspection Date	Industry Class
4Z305	VTNZ GISBORNE - BANKS STREET	01/08/2018	COMMUNITY SERVICES
5W717	VTNZ GISBORNE - BANKS STREET	16/04/2018	COMMERCIAL ROAD TRANSPORT
6F838	VTNZ GISBORNE - BANKS STREET	04/07/2018	COMMERCIAL ROAD TRANSPORT
6Y910	VTNZ GISBORNE - BANKS STREET	19/03/2018	COMMERCIAL ROAD TRANSPORT
7B837	VTNZ GISBORNE - BANKS STREET	27/04/2018	AGRICULTURE/FORESTRY/FISHING
7K728	VTNZ GISBORNE - BANKS STREET	09/05/2018	AGRICULTURE/FORESTRY/FISHING
7P447	VTNZ GISBORNE - BANKS STREET	27/06/2018	AGRICULTURE/FORESTRY/FISHING
7U983	VTNZ GISBORNE - BANKS STREET	05/03/2018	AGRICULTURE/FORESTRY/FISHING
8A839	VTNZ GISBORNE - BANKS STREET	12/03/2018	AGRICULTURE/FORESTRY/FISHING
8K642	VTNZ GISBORNE - BANKS STREET	21/05/2018	AGRICULTURE/FORESTRY/FISHING
9C103	VTNZ GISBORNE - BANKS STREET	25/07/2018	AGRICULTURE/FORESTRY/FISHING
AYC954	VTNZ GISBORNE - BANKS STREET	21/09/2018	COMMERCIAL ROAD TRANSPORT

Released under the Official Information Act 1982



FOR: PACIFIC HAULAGE LIMITED

TSL Licence Number: §18(c)

Report run dates between 28/02/2017 and 27/02/2019

GDU506	VTNZ GISBORNE - BANKS STREET	06/06/2018	COMMERCIAL ROAD TRANSPORT
H469A	VTNZ GISBORNE - BANKS STREET	30/05/2018	COMMERCIAL ROAD TRANSPORT
J169L	VTNZ GISBORNE - BANKS STREET	15/08/2017	COMMERCIAL ROAD TRANSPORT
J765S	VTNZ NAPIER	28/04/2018	AGRICULTURE/FORESTRY/FISHING
J816F	VTNZ GISBORNE - BANKS STREET	28/05/2018	COMMERCIAL ROAD TRANSPORT
J880M	VTNZ FENTON PARK	11/12/2017	BUSINESS/FINANCIAL
K239N	VTNZ BELL BLOCK	02/07/2018	PRIVATE
K436A	MARTINBOROUGH TRANSPORT LTD	18/04/2018	COMMERCIAL ROAD TRANSPORT
K438A	VTNZ GISBORNE - BANKS STREET	14/11/2018	COMMERCIAL ROAD TRANSPORT
K898F	VTNZ GISBORNE - BANKS STREET	11/04/2018	COMMERCIAL ROAD TRANSPORT
KWB512	VTNZ WHANGAREI	18/04/2018	COMMERCIAL ROAD TRANSPORT
KYG607	VTNZ FENTON PARK	19/02/2018	COMMERCIAL ROAD TRANSPORT
L402L	VTNZ WHANGAREI	14/06/2018	BUSINESS/FINANCIAL
LCL769	VTNZ WHANGAREI	03/07/2018	COMMERCIAL ROAD TRANSPORT
LGC224	COMMERCIAL VEHICLE TESTING LIMITED	13/03/2018	COMMERCIAL ROAD TRANSPORT
LHM253	MARTINBOROUGH TRANSPORT LTD	18/04/2018	COMMERCIAL ROAD TRANSPORT
LMF809	VTNZ - WHANGAREI - KEITH ANDREWS	14/06/2018	TOURISM/LEISURE
LUM43	VTNZ GISBORNE - BANKS STREET	28/03/2018	COMMERCIAL ROAD TRANSPORT
M675K	VTNZ - WHANGAREI - KEITH ANDREWS	06/11/2018	COMMERCIAL ROAD TRANSPORT
M829A	VTNZ GISBORNE - BANKS STREET	28/03/2018	COMMERCIAL ROAD TRANSPORT
N102T	VTNZ FENTON PARK	23/05/2018	COMMERCIAL ROAD TRANSPORT
P352C	VTNZ GISBORNE - BANKS STREET	22/08/2018	COMMERCIAL ROAD TRANSPORT
PHL01	VTNZ GISBORNE - BANKS STREET	18/04/2018	COMMERCIAL ROAD TRANSPORT
PHL02	VTNZ GISBORNE - BANKS STREET	04/04/2018	PRIVATE
PHL05	VTNZ GISBORNE - BANKS STREET	11/04/2018	COMMERCIAL ROAD TRANSPORT
PHL06	VTNZ GISBORNE - BANKS STREET	16/05/2018	COMMERCIAL ROAD TRANSPORT

FOR: PACIFIC HAULAGE LIMITED

TSL Licence Number: §18(c)

Report run dates between 28/02/2017 and 27/02/2019

PHL07	VTNZ GISBORNE - BANKS STREET	30/05/2018	COMMERCIAL ROAD TRANSPORT
PHL08	VTNZ GISBORNE - BANKS STREET	28/05/2018	COMMERCIAL ROAD TRANSPORT
PHL09	VTNZ GISBORNE - BANKS STREET	22/03/2018	COMMERCIAL ROAD TRANSPORT
PHL10	VTNZ GISBORNE - BANKS STREET	03/08/2018	COMMERCIAL ROAD TRANSPORT
PHL13	VTNZ GISBORNE - BANKS STREET	21/05/2018	COMMERCIAL ROAD TRANSPORT
PHL14	VTNZ FENTON PARK	23/05/2018	COMMERCIAL ROAD TRANSPORT
PHL15	VTNZ GISBORNE - BANKS STREET	22/08/2018	COMMERCIAL ROAD TRANSPORT
PHL16	VTNZ GISBORNE - BANKS STREET	11/07/2018	COMMERCIAL ROAD TRANSPORT
PHL17	VTNZ GISBORNE - BANKS STREET	25/07/2018	COMMERCIAL ROAD TRANSPORT
PHL18	VTNZ GISBORNE - BANKS STREET	08/05/2018	COMMERCIAL ROAD TRANSPORT
PHL19	VTNZ GISBORNE - BANKS STREET	30/04/2018	COMMERCIAL ROAD TRANSPORT
PHL21	VTNZ GISBORNE - BANKS STREET	14/03/2018	COMMERCIAL ROAD TRANSPORT
PHL22	VTNZ GISBORNE - BANKS STREET	03/01/2018	COMMERCIAL ROAD TRANSPORT
PHL23	VTNZ GISBORNE - BANKS STREET	23/04/2018	COMMERCIAL ROAD TRANSPORT
PHL25	VTNZ GISBORNE - BANKS STREET	29/10/2018	COMMERCIAL ROAD TRANSPORT
PHL26	VTNZ GISBORNE - BANKS STREET	01/08/2018	COMMERCIAL ROAD TRANSPORT
PHL27	VTNZ GISBORNE - BANKS STREET	16/04/2018	COMMERCIAL ROAD TRANSPORT
PHL28	VTNZ GISBORNE - BANKS STREET	04/07/2018	COMMERCIAL ROAD TRANSPORT
PHL29	VTNZ GISBORNE - BANKS STREET	20/06/2018	COMMERCIAL ROAD TRANSPORT
PHL20	VTNZ GISBORNE - BANKS STREET	05/09/2018	COMMERCIAL ROAD TRANSPORT
PHL30	VTNZ GISBORNE - BANKS STREET	29/08/2018	COMMERCIAL ROAD TRANSPORT
PHL31	VTNZ GISBORNE - BANKS STREET	13/06/2018	COMMERCIAL ROAD TRANSPORT
PHL32	VTNZ GISBORNE - BANKS STREET	08/08/2018	COMMERCIAL ROAD TRANSPORT
PHL33	VTNZ GISBORNE - BANKS STREET	26/03/2018	COMMERCIAL ROAD TRANSPORT
PHL34	VTNZ GISBORNE - BANKS STREET	15/08/2018	COMMERCIAL ROAD TRANSPORT
PHL35	VTNZ GISBORNE - BANKS STREET	02/05/2018	COMMERCIAL ROAD TRANSPORT

Released under the Official Information Act 1982

FOR: PACIFIC HAULAGE LIMITED

TSL Licence Number: §18(c)

Report run dates between 28/02/2017 and 27/02/2019

PHL36	VTNZ GISBORNE - BANKS STREET	14/03/2018	COMMERCIAL ROAD TRANSPORT
PHL37	VTNZ GISBORNE - BANKS STREET	27/06/2018	COMMERCIAL ROAD TRANSPORT
PHL38	VTNZ GISBORNE - BANKS STREET	09/05/2018	COMMERCIAL ROAD TRANSPORT
PHL39	VTNZ GISBORNE - BANKS STREET	12/03/2018	COMMERCIAL ROAD TRANSPORT
PHL40	VTNZ GISBORNE - BANKS STREET	05/03/2018	COMMERCIAL ROAD TRANSPORT
PHL41	VTNZ GISBORNE - BANKS STREET	17/05/2018	COMMERCIAL ROAD TRANSPORT
PHL42	VTNZ GISBORNE - BANKS STREET	13/07/2018	COMMERCIAL ROAD TRANSPORT
PHL43	VTNZ GISBORNE - BANKS STREET	24/07/2018	COMMERCIAL ROAD TRANSPORT
Q884L	VTNZ GISBORNE - BANKS STREET	23/04/2018	COMMERCIAL ROAD TRANSPORT
R177T	VTNZ GISBORNE - BANKS STREET	05/04/2018	COMMERCIAL ROAD TRANSPORT
R179F	VTNZ GISBORNE - BANKS STREET	24/05/2018	COMMERCIAL ROAD TRANSPORT
R443P	VTNZ GISBORNE - BANKS STREET	29/08/2018	COMMERCIAL ROAD TRANSPORT
R462K	VTNZ GISBORNE - BANKS STREET	18/07/2018	COMMERCIAL ROAD TRANSPORT
S25E	VTNZ GISBORNE - BANKS STREET	11/07/2018	COMMERCIAL ROAD TRANSPORT
S532N	VTNZ GISBORNE - BANKS STREET	06/06/2018	COMMERCIAL ROAD TRANSPORT
S597H	VTNZ GISBORNE - BANKS STREET	30/04/2018	COMMERCIAL ROAD TRANSPORT
T672A	VTNZ GISBORNE - BANKS STREET	02/05/2018	COMMERCIAL ROAD TRANSPORT
T674A	VTNZ GISBORNE - BANKS STREET	05/09/2018	COMMERCIAL ROAD TRANSPORT
U789M	VTNZ GISBORNE - BANKS STREET	20/06/2018	COMMERCIAL ROAD TRANSPORT
U800M	VTNZ GISBORNE - BANKS STREET	14/03/2018	COMMERCIAL ROAD TRANSPORT
W198L	VTNZ GISBORNE - BANKS STREET	08/08/2018	COMMERCIAL ROAD TRANSPORT
W730M	VTNZ GISBORNE - BANKS STREET	26/03/2018	COMMERCIAL ROAD TRANSPORT
W970G	VTNZ GISBORNE - BANKS STREET	13/06/2018	COMMERCIAL ROAD TRANSPORT
Y951K	VTNZ GISBORNE - BANKS STREET	15/08/2018	COMMERCIAL ROAD TRANSPORT
Z505Y	VTNZ GISBORNE - BANKS STREET	16/05/2018	COMMERCIAL ROAD TRANSPORT
Z745L	VTNZ GISBORNE - BANKS STREET	22/03/2018	COMMERCIAL ROAD TRANSPORT

OTHER INFORMATION

FOR: PACIFIC HAULAGE LIMITED

TSL Licence Number: §18(c)

Report run dates between 28/02/2017 and 27/02/2019

Z760L	VTNZ GISBORNE - BANKS STREET	18/04/2018	COMMERCIAL ROAD TRANSPORT
-------	------------------------------	------------	---------------------------

Released under the Official Information Act 1982

CONFIDENTIAL

Roadside Inspection Results  
From 28/02/2017 To 27/02/2019

Operation:  
Operator: S18(C)  
Roadside Inspections: 103  
Operator Name: PACIFIC HAULAGE LIMITED  
Vehicles Inspected: 184  
Vehicles with Faults: 81

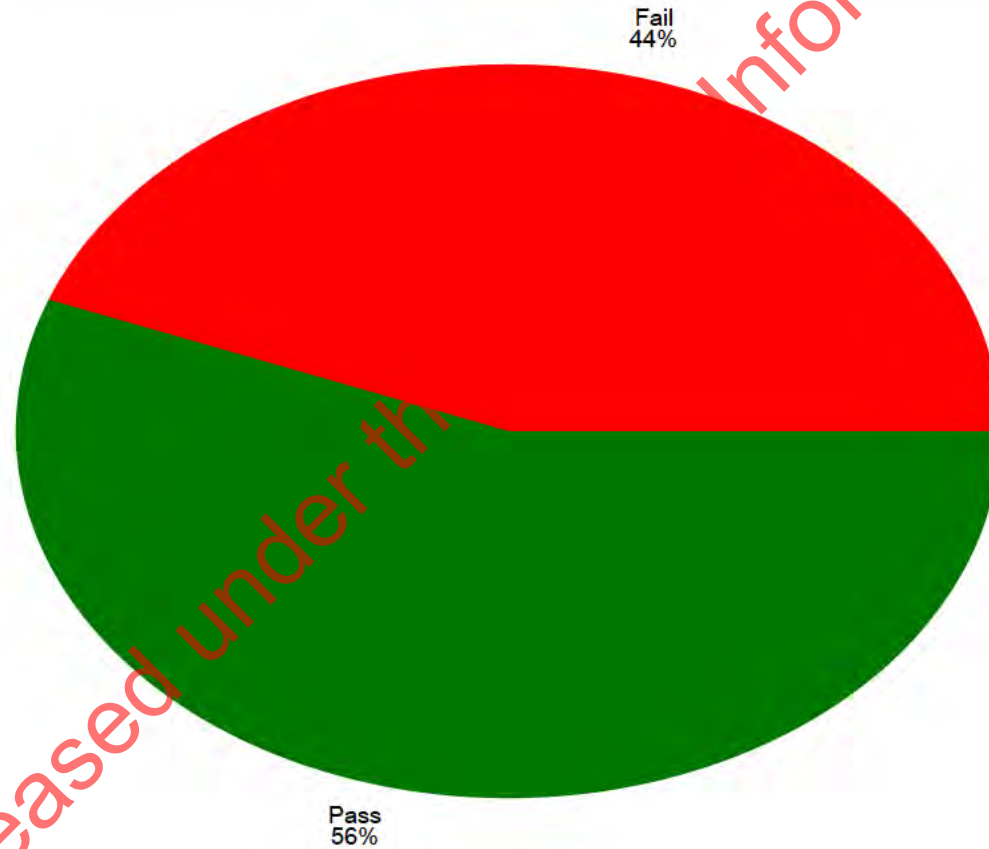

**Roadside Inspection Level Summary**  
From 28/02/2017 To 27/02/2019

Operation:  
Operator: **s18(c)** Operator Name: PACIFIC HAULAGE LIMITED  
Roadside Inspections: 103

Number of Inspections Per Inspection Level		Fault Action by Inspection Level			
Highest Level	Number of Inspections	Level	Action	Fail	Pass
3	42	3	Green 2 action	57	
5	15		Green sticker	21	
5, 3	117		No Action		91
		5	Pink sticker	27	
			Green 2 action	3	
			No Action		11
		5, 3	Pink sticker	1	
			Green 2 action	33	
			Green sticker	16	
			No Action		71
			Pink sticker	21	

Number of Faults Per Inspection Level	
Level	Number of Inspections
3	105
5	4
5, 3	70

Pass/Fail Per Inspection Level		
Level	Fail	Pass
3	23	20
5	4	11
5, 3	51	71
Total	78	102

Released under the Official Information Act 1982

Overview of Roadside Inspections  
From 28/02/2017 To 27/02/2019

Operation:

Operator: s18(c) Operator Name: PACIFIC HAULAGE LIMITED  
Roadside Inspections: 103 Vehicles Inspected: 184 Vehicles with Faults: 81

Total Vehicles Inspected: 184  
Total Passes: 103  
Total Faults: 111  
Total Fails: 81  
  
Average No. Faults per Vehicle: 0.60326  
Average No. Faults per Failed Vehicle: 1.37037  
  
% of Vehicles Failed: 44.0  
% of Vehicles Passed: 56.0

Fault Category	Number of Faults	Percent of Vehicles
	10	9%
Brakes	24	22%
Exterior	8	7%
Lighting	52	47%
Motive	6	5%
Suspension	7	6%
Towing	2	2%
Vehicle	2	2%
Total	111	100%

Action	Total Vehicles	Percent of Vehicles
Pink sticker	27	15%
Green sticker	15	8%
Green 2 action	39	21%
No Action	103	56%
	184	100%

Released under the Official Information Act 1982

**Roadside Inspection Checks**  
From 28/02/2017 To 27/02/2019

Operation:

Operator: **S18(C)**

Roadside Inspections: 103    Vehicles Inspected: 184    Vehicles with Faults: 81

TSL Number: 50108

Operator Name:

PACIFIC HAULAGE LIMITED

Inspection Date	CVIR Sheet Number	Plate	Vehicle Type	Inspection Result	Inspection Level	Action	Fault Category	Fault Desc	COF Expiry Date
07/03/2017	805596	M829A	Trailer/caravan	Fail	5, 3	Green 2 action	Lighting	One indicator light is not working on the rear of combination	24/04/2017
		PHL12	Goods van/truck/utility	Pass	5, 3	No Action			24/04/2017
14/03/2017	805609	5W717	Trailer/caravan	Pass	3	No Action			22/05/2017
		PHL27	Goods van/truck/utility	Pass	3	No Action			19/04/2017
15/03/2017	801635	PHL06	Goods van/truck/utility	Pass	5, 3	No Action			26/05/2017
		Z505Y	Trailer/caravan	Fail	5, 3	Pink sticker	Suspension	Suspension component not fitted/ not securely fitted	21/05/2017
03/04/2017	810486	PHL15	Goods van/truck/utility	Fail	3	Green 2 action	Lighting	One required headlamp is not fitted, not securely attached or is not operational	01/09/2017
			Goods van/truck/utility	Fail	3	Green 2 action	Lighting	Direction indicator lamp is damaged, partially obscured output not affected or is loose.	01/09/2017
			Goods van/truck/utility	Fail	3	Green 2 action	Lighting	A rear tail lamp is not operating, damaged or fully obscured	01/09/2017
11/04/2017	801923	PHL01	Goods van/truck/utility	Fail	5	Green 2 action	Fluid Leaks	Fluid leaks other	04/05/2017
		Z760L	Trailer/caravan	Pass	5	No Action			23/04/2017
16/05/2017	815293	PHL34	Goods van/truck/utility	Pass	5, 3	No Action			27/08/2017
		Y951K	Trailer/caravan	Pass	5, 3	No Action			28/08/2017
17/05/2017	815297	PHL35	Goods van/truck/utility	Fail	5, 3	Green 2 action	Brakes	Air leaks any other system	17/11/2017
		T672A	Trailer/caravan	Pass	5, 3	No Action			08/11/2017





Inspection Date	CVIR Sheet Number	Plate	Vehicle Type	Inspection Result	Inspection Level	Action	Fault Category	Fault Desc	COF Expiry Date
31/05/2017	815336	7B837	Trailer/caravan	Pass	5, 3	No Action			28/10/2017
		PHL25	Goods van/truck/utility	Fail	5, 3	Green 2 action	Brakes	Air leaks any other system	02/11/2017
15/06/2017	816149	PHL35	Goods van/truck/utility	Fail	5, 3	Green 2 action	Lighting	One stop lamp is fitted, not working, excessively damaged or fully obscured. Single vehicle or rear unit of combo	17/11/2017
			Goods van/truck/utility	Fail	5, 3	Green 2 action	Lighting	One required headlamp is not fitted, not securely attached or is not operational	17/11/2017
	816151	L402L	Trailer/caravan	Pass	5, 3	No Action			13/07/2017
		PHL11	Goods van/truck/utility	Fail	5, 3	Green 2 action	Load Anchorage	Bolster not securely fitted or attachment is damaged – no immediate risk of failure	13/07/2017
04/07/2017	816172	PHL35	Goods van/truck/utility	Fail	3	Green 2 action	Lighting	One required headlamp is not fitted, not securely attached or is not operational	17/11/2017
			Goods van/truck/utility	Fail	3	Green 2 action	Lighting	Daytime running lamp works intermittently/operates with fog lights, not securely fitted or damaged	17/11/2017
		T672A	Trailer/caravan	Pass	3	No Action			08/11/2017
05/07/2017	816174	PHL08	Goods van/truck/utility	Fail	3	Green sticker	Lighting	One or more than two daytime running lamps fitted	30/11/2017
		U789M	Trailer/caravan	Fail	3	Green 2 action	Brakes	Air leaks any other system	21/12/2017
			Trailer/caravan	Fail	3	Pink sticker	Lighting	No stop lamps fitted, no stop lamps working, are excessively damaged or fully obscured. Single vehicle or rear unit of combo	21/12/2017
06/07/2017	818086	PHL32	Goods van/truck/utility	Fail	5, 3	Green sticker	Exhaust System	Exhaust system not effective, loose, leaks or excessive noise	26/08/2017
		W198L	Trailer/caravan	Fail	5, 3	Green sticker	Lighting	One side indicator system does not operate	21/08/2017
17/07/2017	816188	H469A	Trailer/caravan	Pass	3	No Action			03/12/2017



Inspection Date	CVIR Sheet Number	Plate	Vehicle Type	Inspection Result	Inspection Level	Action	Fault Category	Fault Desc	COF Expiry Date
		PHL07	Goods van/truck/utility	Pass	3	No Action			16/12/2017
22/07/2017	768999	7P447	Trailer/caravan	Pass	5	No Action			12/01/2018
		PHL37	Goods van/truck/utility	Pass	5	No Action			20/01/2018
01/08/2017	822421	H469A	Trailer/caravan	Fail	5, 3	Green 2 action	Brakes	Air leaks any other system	03/12/2017
		PHL07	Goods van/truck/utility	Pass	5, 3	No Action			16/12/2017
11/08/2017	822440	PHL13	Goods van/truck/utility	Fail	5, 3	Green 2 action	Brakes	Air leaks any other system	30/01/2018
22/08/2017	826921	K898F	Trailer/caravan	Pass	5, 3	No Action			13/10/2017
		PHL05	Goods van/truck/utility	Fail	5, 3	Green 2 action	Lighting	One direction Indicator lamp not working	08/11/2017
05/09/2017	826949	PHL35	Goods van/truck/utility	Pass	3	No Action			17/11/2017
		T672A	Trailer/caravan	Pass	3	No Action			08/11/2017
08/09/2017	826958	L402L	Trailer/caravan	Fail	3	Pink sticker	Lighting	A rear tail lamp is not operational (during darkness) no other rear right lamp operational	13/01/2018
			Trailer/caravan	Fail	3	Pink sticker	Lighting	All side marker lamps not operational (during darkness)	13/01/2018
		PHL11	Goods van/truck/utility	Pass	3	No Action			13/01/2018
11/09/2017	830316	PHL01	Goods van/truck/utility	Pass	3	No Action			04/11/2017
03/10/2017	832193	PHL23	Goods van/truck/utility	Fail	5, 3	Green 2 action	Load Anchorage	Bolster not securely fitted or attachment is damaged – no immediate risk of failure	21/11/2017
		Q884L	Trailer/caravan	Fail	5, 3	Green sticker	Brakes	Stroke of brake chamber exceeds manufacturer's limit - service brake performance doesn't meet legal requirements	30/10/2017
	828698	J880M	Trailer/caravan	Pass	5, 3	No Action			22/12/2017
		PHL29	Goods van/truck/utility	Pass	5, 3	No Action			21/12/2017
	833892	M829A	Trailer/caravan	Fail	5, 3	Pink sticker	Suspension	Leaf spring or coil spring broken, missing or seriously damaged.	03/04/2018

Released under the Official Information Act 1982



Inspection Date	CVIR Sheet Number	Plate	Vehicle Type	Inspection Result	Inspection Level	Action	Fault Category	Fault Desc	COF Expiry Date
		PHL12	Goods van/truck/utility	Fail	5, 3	Pink sticker	Brakes	Park brake actuator missing/not operational/does not lock into position, remains applied when released, is not securely fastened & may detach. Risk of inadvertent release	24/10/2017
	830350	7B837	Trailer/caravan	Fail	5, 3	Green 2 action	Cab, Chassis and Body	Load containment structure damaged or not securely fitted - risk of failure, vehicle unloaded (includes cab guard)	28/10/2017
		PHL25	Goods van/truck/utility	Pass	5, 3	No Action			02/11/2017
	833895	5W717	Trailer/caravan	Pass	5, 3	No Action			31/10/2017
		PHL27	Goods van/truck/utility	Pass	5, 3	No Action			19/10/2017
04/10/2017	832202	J880M	Trailer/caravan	Fail	5, 3	Pink sticker	Wheels and Tyres	A tyre is damaged - operation affected and/or failure imminent	22/12/2017
		PHL29	Goods van/truck/utility	Pass	5, 3	No Action			21/12/2017
	832205	PHL20	Goods van/truck/utility	Pass	5, 3	No Action			06/03/2018
		T674A	Trailer/caravan	Pass	5, 3	No Action			07/03/2018
	832209	GDU506	Goods van/truck/utility	Pass	5, 3	No Action			05/12/2017
		S532N	Trailer/caravan	Pass	5, 3	No Action			20/12/2017
	832115	7K728	Trailer/caravan	Pass	5, 3	No Action			21/12/2017
		PHL38	Goods van/truck/utility	Pass	5, 3	No Action			22/11/2017
	830360	K239N	Trailer/caravan	Pass	5, 3	No Action			30/03/2018
		PHL10	Goods van/truck/utility	Pass	5, 3	No Action			30/03/2018
05/10/2017	834833	PHL35	Goods van/truck/utility	Fail	5, 3	Green 2 action	Lighting	A headlamp is damaged failure is imminent or light output on either side is not approx equal	17/11/2017
		T672A	Trailer/caravan	Fail	5, 3	Green 2 action	PSV Wheels and Tyres	Tread in dual set 1 tyre below minimum	08/11/2017

Released under the Official Information Act 1982



Inspection Date	CVIR Sheet Number	Plate	Vehicle Type	Inspection Result	Inspection Level	Action	Fault Category	Fault Desc	COF Expiry Date
	836073	PHL22	Goods van/truck/utility	Fail	5, 3	Pink sticker	Brakes	Park brake actuator missing/not operational/does not lock into position, remains applied when released, is not securely fastened & may detach. Risk of inadvertent release	26/01/2018
		R462K	Trailer/caravan	Pass	5, 3	No Action			26/01/2018
11/10/2017	833637	H469A	Trailer/caravan	Fail	3	Green 2 action	Brakes	Air leaks any other system	03/12/2017
		PHL07	Goods van/truck/utility	Pass	3	No Action			16/12/2017
19/10/2017	833650	K438A	Trailer/caravan	Fail	3	Pink sticker	Wheels and Tyres	A tyre is damaged – operation affected and/or failure imminent	17/11/2017
		PHL04	Goods van/truck/utility	Fail	3	Green 2 action	Load Anchorage	Bolster not securely fitted or attachment is damaged – no immediate risk of failure	02/11/2017
01/11/2017	837227	PHL36	Goods van/truck/utility	Fail	3	Green sticker	Lighting	Direction indicator lamp is damaged, fully obscured or output affected/failure imminent or is not securely fitted (detachment is imminent)	30/03/2018
02/11/2017	837235	5W717	Trailer/caravan	Fail	3	Pink sticker	Lighting	No stop lamps fitted, no stop lamps working, are excessively damaged or fully obscured. Single vehicle or rear unit of combo	30/04/2018
		PHL27	Goods van/truck/utility	Fail	3	Green 2 action	Lighting	A headlamp is damaged failure is imminent or light output on either side is not approx equal	19/04/2018
			Goods van/truck/utility	Fail	3	Green sticker	Lighting	One or more than two daytime running lamps fitted	19/04/2018
14/11/2017	814676	K438A	Trailer/caravan	Fail	5	Pink sticker	Lighting	No stop lamps fitted, no stop lamps working, are excessively damaged or fully obscured. Single vehicle or rear unit of combo	17/05/2018
		PHL04	Goods van/truck/utility	Pass	5	No Action			02/05/2018

Released under the Official Information Act 1982



Inspection Date	CVIR Sheet Number	Plate	Vehicle Type	Inspection Result	Inspection Level	Action	Fault Category	Fault Desc	COF Expiry Date
30/11/2017	837267	K239N	Trailer/caravan	Fail	5, 3	Green 2 action	Lighting	Side marker lamp not operational, not secure, damaged or obscured	30/03/2018
		PHL10	Goods van/truck/utility	Fail	5, 3	Green 2 action	Lighting	One or more front park lamps not operational (anytime)	30/03/2018
05/12/2017	839682		Goods van/truck/utility	Fail	3	Green 2 action	Lighting	One or more front park lamps not operational (anytime)	30/03/2018
	839683	PHL04	Goods van/truck/utility	Pass	3	No Action			02/05/2018
11/01/2018	841627	PHL16	Goods van/truck/utility	Fail	5, 3	Pink sticker	Wheels and Tyres	A tyre is damaged – operation affected and/or failure imminent	26/07/2018
			Goods van/truck/utility	Fail	5, 3	Green sticker	Mudguards	One mudguard missing/does not comply or a mudflap not fitted to a twin tyred axle	26/07/2018
		S25E	Trailer/caravan	Pass	5, 3	No Action			26/07/2018
18/01/2018	837646	6Y910	Trailer/caravan	Pass	5	No Action			18/01/2018
		PHL36	Goods van/truck/utility	Pass	5	No Action			18/01/2018
08/02/2018	843246	PHL31	Goods van/truck/utility	Fail	5	Green 2 action	Lighting	A headlamp is damaged failure is imminent or light output on either side is not approx equal	18/06/2018
		W970G	Trailer/caravan	Pass	5	No Action			18/06/2018
27/02/2018	854254	PHL06	Goods van/truck/utility	Pass	5, 3	No Action			26/05/2018
		Z505Y	Trailer/caravan	Pass	5, 3	No Action			21/05/2018
03/04/2018	854929	PHL26	Goods van/truck/utility	Pass	3	No Action			01/08/2018
13/04/2018	850703	PHL02	Goods van/truck/utility	Fail	5	Green 2 action	Wheels and Tyres	1 wheel nut loose/missing, 1 stud damaged/missing	07/10/2018
		R177T	Trailer/caravan	Pass	5	No Action			07/10/2018
16/04/2018	854940	P352C	Trailer/caravan	Pass	3	No Action			20/09/2018
		PHL15	Goods van/truck/utility	Fail	3	Green 2 action	Load Anchorage	Bolster not securely fitted or attachment is damaged – no immediate risk of failure	01/09/2018
26/04/2018	857314	PHL02	Goods van/truck/utility	Pass	3	No Action			07/10/2018
		R177T	Trailer/caravan	Fail	3	Green 2 action	Lighting	One required rear reflector fitted, not securely fitted, colour other than red, anytime	07/10/2018

Inspection Date	CVIR Sheet Number	Plate	Vehicle Type	Inspection Result	Inspection Level	Action	Fault Category	Fault Desc	COF Expiry Date
03/05/2018	854337	PHL18	Goods van/truck/utility	Pass	5, 3	No Action			08/11/2018
11/05/2018	850731	PHL29	Goods van/truck/utility	Pass	5	No Action			21/06/2018
		U789M	Trailer/caravan	Pass	5	No Action			21/06/2018
17/05/2018	850732	PHL23	Goods van/truck/utility	Pass	5	No Action			21/11/2018
20/06/2018	857357	PHL32	Goods van/truck/utility	Pass	3	No Action			26/08/2018
	857358	PHL27	Goods van/truck/utility	Fail	3	Pink sticker	Lighting	No stop lamps fitted, no stop lamps working, are excessively damaged or fully obscured. Single vehicle or rear unit of combo	19/10/2018
	857359	GDU506	Goods van/truck/utility	Fail	3	Green 2 action	Lighting	Daytime running lamp works intermittently/operates with fog lights, not securely fitted or damaged	06/12/2018
25/06/2018	861239	PHL20	Goods van/truck/utility	Fail	3	Green 2 action	Lighting	One required rear reflector fitted, not securely fitted, colour other than red, anytime	07/09/2018
			Goods van/truck/utility	Fail	3	Green 2 action	Lighting	A fog lamp is insecure, damaged or out of alignment	07/09/2018
			Goods van/truck/utility	Fail	3	Green 2 action	Lighting	One direction Indicator lamp not working	07/09/2018
	861240	PHL02	Goods van/truck/utility	Fail	3	Green sticker	Lighting	Direction indicator lamp is damaged, fully obscured or output affected/failure imminent or is not securely fitted (detachment is imminent)	07/10/2018
	861241	PHL12	Goods van/truck/utility	Fail	3	Green 2 action	Lighting	One direction Indicator lamp not working	24/10/2018
			Goods van/truck/utility	Fail	3	Green 2 action	Lighting	One or more front park lamps not operational (anytime)	24/10/2018
07/07/2018	861259	7P447	Trailer/caravan	Pass	3	No Action			06/01/2019
		PHL37	Goods van/truck/utility	Pass	3	No Action			06/01/2019

Inspection Date	CVIR Sheet Number	Plate	Vehicle Type	Inspection Result	Inspection Level	Action	Fault Category	Fault Desc	COF Expiry Date
13/07/2018	861267		Goods van/truck/utility	Fail	3	Green sticker	Mudguards	One mudguard missing/does not comply or a mudflap not fitted to a twin tyred axle	06/01/2019
17/07/2018	861276	PHL07	Goods van/truck/utility	Fail	3	Green 2 action	Lighting	Stop lamp emits colour other than red, or is obscured	16/12/2018
10/08/2018	867923	PHL02	Goods van/truck/utility	Pass	2	No Action			07/10/2018
		R177T	Trailer/caravan	Fail	2	Pink sticker	Load Anchorage	Sliding bolster – no locking mechanism	07/10/2018
			Trailer/caravan	Fail	2	Green 2 action	Lighting	One direction Indicator lamp not working	07/10/2018
	867925	GDU506	Goods van/truck/utility	Fail	3	Green 2 action	Lighting	Daytime running lamp works intermittently/operates with fog lights, not securely fitted or damaged	06/12/2018
16/08/2018	872864	M829A	Trailer/caravan	Fail	3	Green 2 action	Lighting	One required rear reflector fitted, not securely fitted, colour other than red, anytime	03/10/2018
		PHL12	Goods van/truck/utility	Pass	3	No Action			24/10/2018
17/08/2018	872868	9Z516	Trailer/caravan	Pass	3	No Action			24/01/2019
		PHL43	Goods van/truck/utility	Pass	3	No Action			24/01/2019
17/09/2018	872898	PHL01	Goods van/truck/utility	Pass	5, 3	No Action			04/11/2018
		Z760L	Trailer/caravan	Fail	5, 3	Pink sticker	Lighting	No stop lamps fitted, no stop lamps working, are excessively damaged or fully obscured. Single vehicle or rear unit of combo	23/10/2018
27/09/2018	097707	PHL05	Goods van/truck/utility	Fail	5, 3	Green 2 action	Lighting	One required headlamp is not fitted, not securely attached or is not operational	02/11/2018
03/10/2018	114451	PHL30	Goods van/truck/utility	Pass	5, 3	No Action			04/03/2019
		R443P	Trailer/caravan	Fail	5, 3	Pink sticker	Load Anchorage	Sliding bolster – no locking mechanism	02/03/2019



Inspection Date	CVIR Sheet Number	Plate	Vehicle Type	Inspection Result	Inspection Level	Action	Fault Category	Fault Desc	COF Expiry Date
26/10/2018	105572	K898F	Trailer/caravan	Fail	5, 3	Pink sticker	Lighting	No stop lamps fitted, no stop lamps working, are excessively damaged or fully obscured. Single vehicle or rear unit of combo	13/04/2019
		PHL05	Goods van/truck/utility	Pass	5, 3	No Action			02/05/2019
30/10/2018	105582	PHL12	Goods van/truck/utility	Pass	5, 3	No Action			24/04/2019
08/11/2018	114485	PHL06	Goods van/truck/utility	Pass	5, 3	No Action			26/11/2018
		Z505Y	Trailer/caravan	Pass	5, 3	No Action			21/11/2018
12/11/2018	117905	PHL32	Goods van/truck/utility	Fail	5, 3	Green sticker	Exhaust System	Exhaust system not effective, loose, leaks or excessive noise	26/02/2019
		W198L	Trailer/caravan	Fail	5, 3	Pink sticker	Brakes	ABS/EBS system is not operating - Combination vehicle	21/02/2019
13/11/2018	117057	9Z511	Trailer/caravan	Pass	5, 3	No Action			13/01/2019
		PHL42	Goods van/truck/utility	Pass	5, 3	No Action			13/01/2019
	117159	PHL16	Goods van/truck/utility	Pass	5, 3	No Action			26/01/2019
		S25E	Trailer/caravan	Pass	5, 3	No Action			26/01/2019
	114496	PHL35	Goods van/truck/utility	Fail	5, 3	Green sticker	Brakes	Spring brake/electric brake control for parking brakes not protected from inadvertent release	17/05/2019
		T672A	Trailer/caravan	Pass	5, 3	No Action			08/05/2019
	105599	6Y910	Trailer/caravan	Fail	5, 3	Green 2 action	Brakes	Suzie coil hose does not comply, support spring missing/ineffective	19/03/2019
		PHL36	Goods van/truck/utility	Pass	5, 3	No Action			14/03/2019
	114499	K898F	Trailer/caravan	Fail	5, 3	Green 2 action	Load Anchorage	Bolster not securely fitted or attachment is damaged – no immediate risk of failure	13/04/2019
		PHL05	Goods van/truck/utility	Fail	5, 3	Green sticker	Brakes	Spring brake/electric brake control for parking brakes not protected from inadvertent release	02/05/2019
			Goods van/truck/utility	Fail	5, 3	Pink sticker	Wheels and Tyres	Wheel nuts loose/missing or studs damaged/missing - safety risk	02/05/2019
14/11/2018	117925	PHL23	Goods van/truck/utility	Pass	5, 3	No Action			21/05/2019





Inspection Date	CVIR Sheet Number	Plate	Vehicle Type	Inspection Result	Inspection Level	Action	Fault Category	Fault Desc	COF Expiry Date
		Q884L	Trailer/caravan	Fail	5, 3	Pink sticker	Suspension	Suspension component not fitted/ not securely fitted	30/04/2019
			Trailer/caravan	Fail	5, 3	Green 2 action	Wheels and Tyres	Tyre not correctly inflated – operation/control not affected	30/04/2019
	114553	PHL20	Goods van/truck/utility	Fail	5, 3	Green sticker	Brakes	Spring brake/electric brake control for parking brakes not protected from inadvertent release	07/03/2019
			Goods van/truck/utility	Fail	5, 3	Green sticker	Suspension	Shock absorber missing, damaged or leaking excessively (wet or dripping)	07/03/2019
		T674A	Trailer/caravan	Fail	5, 3	Green 2 action	Load Anchorage	Bolster not securely fitted or attachment is damaged – no immediate risk of failure	07/03/2019
			Trailer/caravan	Fail	5, 3	Pink sticker	Brakes	Air leak low air pressure <30 seconds	07/03/2019
	114556	6F838	Trailer/caravan	Fail	5, 3	Green 2 action	Brakes	Suzie coil hose does not comply, support spring missing/ineffective	18/01/2019
			Trailer/caravan	Fail	5, 3	Green 2 action	Ball-race Turntables	Ball-race turntable fasteners loose (other)	18/01/2019
			Trailer/caravan	Fail	5, 3	Pink sticker	Brakes	ABS/EBS system is not operating - Combination vehicle	18/01/2019
			Trailer/caravan	Fail	5, 3	Green 2 action	Lighting	One required rear reflector fitted, not securely fitted, colour other than red, anytime	18/01/2019
		PHL28	Goods van/truck/utility	Fail	5, 3	Green 2 action	Lighting	One required headlamp is not fitted, not securely attached or is not operational	18/01/2019
			Goods van/truck/utility	Fail	5, 3	Green 2 action	Lighting	Daytime running lamp works intermittently/operates with fog lights, not securely fitted or damaged	18/01/2019
	117929	PHL18	Goods van/truck/utility	Pass	5, 3	No Action			08/05/2019
		R179F	Trailer/caravan	Pass	5, 3	No Action			24/05/2019



Inspection Date	CVIR Sheet Number	Plate	Vehicle Type	Inspection Result	Inspection Level	Action	Fault Category	Fault Desc	COF Expiry Date
	114558	N102T	Trailer/caravan	Fail	5, 3	Green 2 action	Lighting	One direction Indicator lamp not working	30/04/2019
		PHL14	Goods van/truck/utility	Fail	5, 3	Green 2 action	Fluid Leaks	Fluid leaks other	30/04/2019
			Goods van/truck/utility	Fail	5, 3	Green sticker	Brakes	Spring brake/electric brake control for parking brakes not protected from inadvertent release	30/04/2019
			Goods van/truck/utility	Fail	5, 3	Green sticker	Exhaust System	Exhaust system not effective, loose, leaks or excessive noise	30/04/2019
15/11/2018	117173	4Z305	Trailer/caravan	Pass	5, 3	No Action			01/02/2019
		PHL26	Goods van/truck/utility	Pass	5, 3	No Action			01/02/2019
	117175	5W717	Trailer/caravan	Fail	5, 3	Green sticker	Brakes	Stroke of brake chamber exceeds manufacturer's limit - service brake performance doesn't meet legal requirements	30/04/2019
		PHL27	Goods van/truck/utility	Pass	5, 3	No Action			19/04/2019
	114567	PHL34	Goods van/truck/utility	Pass	5, 3	No Action			27/02/2019
		Y951K	Trailer/caravan	Fail	5, 3	Green sticker	Brakes	Reservoir/master cylinder/servo unit leaks, or is loose/otherwise damaged or worn	28/02/2019
			Trailer/caravan	Fail	5, 3	Green sticker	Brakes	Air leak low air pressure >30 seconds	28/02/2019
	121785	9Z506	Trailer/caravan	Pass	5, 3	No Action			09/06/2019
		PHL41	Goods van/truck/utility	Pass	5, 3	No Action			17/05/2019
	121783	PHL02	Goods van/truck/utility	Pass	5, 3	No Action			08/04/2019
		R177T	Trailer/caravan	Fail	5, 3	Pink sticker	Wheels and Tyres	Side wall unzipping	08/04/2019
	117941	9Z516	Trailer/caravan	Pass	5, 3	No Action			24/01/2019
		PHL43	Goods van/truck/utility	Pass	5, 3	No Action			24/01/2019
26/11/2018	114589	4Z305	Trailer/caravan	Pass	5, 3	No Action			01/02/2019
		PHL26	Goods van/truck/utility	Pass	5, 3	No Action			01/02/2019
03/12/2018	114599	PHL33	Goods van/truck/utility	Fail	5, 3	Green 2 action	Lighting	One required headlamp is not fitted, not securely attached or is not operational	03/04/2019



Inspection Date	CVIR Sheet Number	Plate	Vehicle Type	Inspection Result	Inspection Level	Action	Fault Category	Fault Desc	COF Expiry Date
			Goods van/truck/utility	Fail	5, 3	Green sticker	Brakes	Spring brake/electric brake control for parking brakes not protected from inadvertent release	03/04/2019
	123554	PHL09	Goods van/truck/utility	Pass	5, 3	No Action			25/03/2019
		Z745L	Trailer/caravan	Pass	5, 3	No Action			24/03/2019
12/12/2018	107316	4Z305	Trailer/caravan	Pass	5, 3	No Action			01/02/2019
		PHL26	Goods van/truck/utility	Pass	5, 3	No Action			01/02/2019
	107318	PHL20	Goods van/truck/utility	Pass	5, 3	No Action			07/03/2019
		T674A	Trailer/caravan	Fail	5, 3	Pink sticker	Suspension	Air bag damaged/fully deflated – laden	07/03/2019
13/12/2018	107324	7B837	Trailer/caravan	Fail	5, 3	Pink sticker	Brakes	Air brake pipe, hose, connector or component leaking - audible air leak from a pipe, hose, connector or component.	29/04/2019
			Trailer/caravan	Fail	5, 3	Green sticker	Ball-race Turntables	Ball-race turntable bolts loose – up to 25% (max 3)	29/04/2019
		PHL25	Goods van/truck/utility	Pass	5, 3	No Action			02/05/2019
18/12/2018	107332	8K642	Trailer/caravan	Pass	5, 3	No Action			29/05/2019
		PHL13	Goods van/truck/utility	Pass	5, 3	No Action			15/06/2019
19/12/2018	123569	PHL30	Goods van/truck/utility	Fail	5, 3	Green 2 action	Fluid Leaks	Fluid leaks other	04/03/2019
		R443P	Trailer/caravan	Fail	5, 3	Green 2 action	Wheels and Tyres	A tyre is damaged/imbedded object – operation not affected	02/03/2019
			Trailer/caravan	Fail	5, 3	Pink sticker	Suspension	Suspension component not fitted/ not securely fitted	02/03/2019
05/02/2019	123590	K898F	Trailer/caravan	Fail	6, 3	Green 2 action	Lighting	A rear tail lamp is not operating, damaged or fully obscured	13/04/2019
			Trailer/caravan	Fail	6, 3	Green 2 action	Suspension	Axle locating device loose – includes loose “U” bolts	13/04/2019
		PHL05	Goods van/truck/utility	Fail	6, 3	Green 2 action	Lighting	A headlamp is damaged failure is imminent or light output on either side is not approx equal	02/05/2019
14/02/2019	107362	7P447	Trailer/caravan	Pass	5, 3	No Action			01/07/2019
		PHL37	Goods van/truck/utility	Pass	5, 3	No Action			01/07/2019



Inspection Date	CVIR Sheet Number	Plate	Vehicle Type	Inspection Result	Inspection Level	Action	Fault Category	Fault Desc	COF Expiry Date
19/02/2019	126815	7K728	Trailer/caravan	Pass	5, 3	No Action			07/06/2019
		PHL38	Goods van/truck/utility	Pass	5, 3	No Action			22/05/2019
	126816	PHL01	Goods van/truck/utility	Pass	5, 3	No Action			04/05/2019
		Z760L	Trailer/caravan	Pass	5, 3	No Action			23/04/2019
20/02/2019	126823	PHL06	Goods van/truck/utility	Fail	5, 3	Green 2 action	Lighting	Side marker lamp not operational, not secure, damaged or obscured	26/05/2019
		Z505Y	Trailer/caravan	Pass	5, 3	No Action			21/05/2019
21/02/2019	126828	PHL35	Goods van/truck/utility	Pass	5, 3	No Action			17/05/2019
		T672A	Trailer/caravan	Fail	5, 3	Pink sticker	Brakes	Air brake pipe, hose, connector or component leaking - audible air leak from a pipe, hose, connector or component.	08/05/2019
	126829	PHL02	Goods van/truck/utility	Pass	5, 3	No Action			08/04/2019
		R177T	Trailer/caravan	Fail	5, 3	Green 2 action	Lighting	Side marker lamp not operational, not secure, damaged or obscured	08/04/2019
			Trailer/caravan	Fail	5, 3	Pink sticker	Lighting	No stop lamps fitted, no stop lamps working, are excessively damaged or fully obscured. Single vehicle or rear unit of combo	08/04/2019
			Trailer/caravan	Fail	5, 3	Green 2 action	Lighting	A rear tail lamp is not operating, damaged or fully obscured	08/04/2019
			Trailer/caravan	Fail	5, 3	Pink sticker	Lighting	Whole indicator system does not operate	08/04/2019

Released under the Official Information Act 1982

Total Vehicles Inspected:		Action Taken		Total Vehicles	Fault Action	Total Vehicles
Total Faults:	111	Green sticker		15	Green sticker	21
Total Fails:	81	Green 2 action		39	Green 2 action	61
Total Passes:	103	No Action		103	No Action	103
Average No. Faults per Vehicle:	0.6033	Pink sticker		27	Pink sticker	29
Average No. Faults per Failed Vehicle:	1.37			184		214

Released under the Official Information Act 1982

**Roadside Inspection Checks**  
From 28/02/2017 To 27/02/2019

Operation:

Operator: s18(c)

Roadside Inspections: 103      Vehicles Inspected: 184      Vehicles with Faults: 81

TSL Number: s18(c)

Operator Name:

PACIFIC HAULAGE LIMITED

DL Number: s9(2)(a)

Driver: s9(2)(a)

Inspection Date	CVIR Sheet Number	Plate	Vehicle Type	Inspection Result	Inspection Level	Action	Fault Category	Fault Desc	COF Expiry Date
07/03/2017	805596	M829A	Trailer/caravan	Fail	5, 3	Green 2 action	Lighting	One indicator light is not working on the rear of combination	24/04/2017
07/03/2017	805596	PHL12	Goods van/truck/utility	Pass	5, 3	No Action			24/04/2017
04/10/2017	832209	GDU506	Goods van/truck/utility	Pass	5, 3	No Action			05/12/2017
04/10/2017	832209	S532N	Trailer/caravan	Pass	5, 3	No Action			20/12/2017

DL Number: s9(2)(a)

Driver: s9(2)(a)

Inspection Date	CVIR Sheet Number	Plate	Vehicle Type	Inspection Result	Inspection Level	Action	Fault Category	Fault Desc	COF Expiry Date
14/03/2017	805609	5W717	Trailer/caravan	Pass	3	No Action			22/05/2017
14/03/2017	805609	PHL27	Goods van/truck/utility	Pass	3	No Action			19/04/2017
03/10/2017	833895	5W717	Trailer/caravan	Pass	5, 3	No Action			31/10/2017
03/10/2017	833895	PHL27	Goods van/truck/utility	Pass	5, 3	No Action			19/10/2017
02/11/2017	837235	5W717	Trailer/caravan	Fail	3	Pink sticker	Lighting	No stop lamps fitted, no stop lamps working, are excessively damaged or fully obscured. Single vehicle or rear unit of combo	30/04/2018
02/11/2017	837235	PHL27	Goods van/truck/utility	Fail	3	Green 2 action	Lighting	A headlamp is damaged failure is imminent or light output on either side is not approx equal	19/04/2018



Inspection Date	CVIR Sheet Number	Plate	Vehicle Type	Inspection Result	Inspection Level	Action	Fault Category	Fault Desc	COF Expiry Date
02/11/2017	837235	PHL27	Goods van/truck/utility	Fail	3	Green sticker	Lighting	One or more than two daytime running lamps fitted	19/04/2018
20/06/2018	857358	PHL27	Goods van/truck/utility	Fail	3	Pink sticker	Lighting	No stop lamps fitted, no stop lamps working, are excessively damaged or fully obscured. Single vehicle or rear unit of combo	19/10/2018
15/11/2018	117175	5W717	Trailer/caravan	Fail	5, 3	Green sticker	Brakes	Stroke of brake chamber exceeds manufacturer's limit - service brake performance doesn't meet legal requirements	30/04/2019
15/11/2018	117175	PHL27	Goods van/truck/utility	Pass	5, 3	No Action			19/04/2019

DL Number: s9(2)(a) Driver: s9(2)(a)

Inspection Date	CVIR Sheet Number	Plate	Vehicle Type	Inspection Result	Inspection Level	Action	Fault Category	Fault Desc	COF Expiry Date
15/03/2017	801635	PHL06	Goods van/truck/utility	Pass	5, 3	No Action			26/05/2017
15/03/2017	801635	Z505Y	Trailer/caravan	Fail	5, 3	Pink sticker	Suspension	Suspension component not fitted/ not securely fitted	21/05/2017

DL Number: s9(2)(a) Driver: s9(2)(a)

Inspection Date	CVIR Sheet Number	Plate	Vehicle Type	Inspection Result	Inspection Level	Action	Fault Category	Fault Desc	COF Expiry Date
03/04/2017	810486	PHL15	Goods van/truck/utility	Fail	3	Green 2 action	Lighting	One required headlamp is not fitted, not securely attached or is not operational	01/09/2017
03/04/2017	810486	PHL15	Goods van/truck/utility	Fail	3	Green 2 action	Lighting	Direction indicator lamp is damaged, partially obscured output not affected or is loose.	01/09/2017
03/04/2017	810486	PHL15	Goods van/truck/utility	Fail	3	Green 2 action	Lighting	A rear tail lamp is not operating, damaged or fully obscured	01/09/2017

DL Number: s9(2)(a) Driver: s9(2)(a)

Released under the Official Information Act 1982



Inspection Date	CVIR Sheet Number	Plate	Vehicle Type	Inspection Result	Inspection Level	Action	Fault Category	Fault Desc	COF Expiry Date
11/04/2017	801923	PHL01	Goods van/truck/utility	Fail	5	Green 2 action	Fluid Leaks	Fluid leaks other	04/05/2017
11/04/2017	801923	Z760L	Trailer/caravan	Pass	5	No Action			23/04/2017
11/09/2017	830316	PHL01	Goods van/truck/utility	Pass	3	No Action			04/11/2017

DL Number: s9(2)(a) Driver: s9(2)(a)

Inspection Date	CVIR Sheet Number	Plate	Vehicle Type	Inspection Result	Inspection Level	Action	Fault Category	Fault Desc	COF Expiry Date
16/05/2017	815293	PHL34	Goods van/truck/utility	Pass	5, 3	No Action			27/08/2017
16/05/2017	815293	Y951K	Trailer/caravan	Pass	5, 3	No Action			28/08/2017
15/11/2018	114567	PHL34	Goods van/truck/utility	Pass	5, 3	No Action			27/02/2019
15/11/2018	114567	Y951K	Trailer/caravan	Fail	5, 3	Green sticker	Brakes	Air leak low air pressure >30 seconds	28/02/2019
15/11/2018	114567	Y951K	Trailer/caravan	Fail	5, 3	Green sticker	Brakes	Reservoir/master cylinder/servo unit leaks, or is loose/otherwise damaged or worn	28/02/2019

DL Number: s9(2)(a) Driver: s9(2)(a)

Inspection Date	CVIR Sheet Number	Plate	Vehicle Type	Inspection Result	Inspection Level	Action	Fault Category	Fault Desc	COF Expiry Date
17/05/2017	815297	PHL35	Goods van/truck/utility	Fail	5, 3	Green 2 action	Brakes	Air leaks any other system	17/11/2017
17/05/2017	815297	T672A	Trailer/caravan	Pass	5, 3	No Action			08/11/2017
15/06/2017	816149	PHL35	Goods van/truck/utility	Fail	5, 3	Green 2 action	Lighting	One required headlamp is not fitted, not securely attached or is not operational	17/11/2017
15/06/2017	816149	PHL35	Goods van/truck/utility	Fail	5, 3	Green 2 action	Lighting	One stop lamp is fitted, not working, excessively damaged or fully obscured. Single vehicle or rear unit of combo	17/11/2017
04/07/2017	816172	PHL35	Goods van/truck/utility	Fail	3	Green 2 action	Lighting	One required headlamp is not fitted, not securely attached or is not operational	17/11/2017

Released under the Official Information Act 1982





Inspection Date	CVIR Sheet Number	Plate	Vehicle Type	Inspection Result	Inspection Level	Action	Fault Category	Fault Desc	COF Expiry Date
04/07/2017	816172	PHL35	Goods van/truck/utility	Fail	3	Green 2 action	Lighting	Daytime running lamp works intermittently/operates with fog lights, not securely fitted or damaged	17/11/2017
04/07/2017	816172	T672A	Trailer/caravan	Pass	3	No Action			08/11/2017
05/09/2017	826949	PHL35	Goods van/truck/utility	Pass	3	No Action			17/11/2017
05/09/2017	826949	T672A	Trailer/caravan	Pass	3	No Action			08/11/2017

DL Number: s9(2)(a)

Driver: s9(2)(a)

Inspection Date	CVIR Sheet Number	Plate	Vehicle Type	Inspection Result	Inspection Level	Action	Fault Category	Fault Desc	COF Expiry Date
31/05/2017	815336	7B837	Trailer/caravan	Pass	5, 3	No Action			28/10/2017
31/05/2017	815336	PHL25	Goods van/truck/utility	Fail	5, 3	Green 2 action	Brakes	Air leaks any other system	02/11/2017
03/10/2017	830350	7B837	Trailer/caravan	Fail	5, 3	Green 2 action	Cab, Chassis and Body	Load containment structure damaged or not securely fitted - risk of failure, vehicle unloaded (includes cab guard)	28/10/2017
03/10/2017	830350	PHL25	Goods van/truck/utility	Pass	5, 3	No Action			02/11/2017
13/12/2018	107324	7B837	Trailer/caravan	Fail	5, 3	Pink sticker	Brakes	Air brake pipe, hose, connector or component leaking - audible air leak from a pipe, hose, connector or component.	29/04/2019
13/12/2018	107324	7B837	Trailer/caravan	Fail	5, 3	Green sticker	Ball-race Turntables	Ball-race turntable bolts loose - up to 25% (max 3)	29/04/2019
13/12/2018	107324	PHL25	Goods van/truck/utility	Pass	5, 3	No Action			02/05/2019

DL Number: s9(2)(a)

Driver: s9(2)(a)

Inspection Date	CVIR Sheet Number	Plate	Vehicle Type	Inspection Result	Inspection Level	Action	Fault Category	Fault Desc	COF Expiry Date
15/06/2017	816151	L402L	Trailer/caravan	Pass	5, 3	No Action			13/07/2017

Released under the Official Information Act 1982

Inspection Date	CVIR Sheet Number	Plate	Vehicle Type	Inspection Result	Inspection Level	Action	Fault Category	Fault Desc	COF Expiry Date
15/06/2017	816151	PHL11	Goods van/truck/utility	Fail	5, 3	Green 2 action	Load Anchorage	Bolster not securely fitted or attachment is damaged – no immediate risk of failure	13/07/2017
18/12/2018	107332	8K642	Trailer/caravan	Pass	5, 3	No Action			29/05/2019
18/12/2018	107332	PHL13	Goods van/truck/utility	Pass	5, 3	No Action			15/06/2019

DL Number: s9(2)(a) Driver: s9(2)(a)

Inspection Date	CVIR Sheet Number	Plate	Vehicle Type	Inspection Result	Inspection Level	Action	Fault Category	Fault Desc	COF Expiry Date
05/07/2017	816174	PHL08	Goods van/truck/utility	Fail	3	Green sticker	Lighting	One or more than two daytime running lamps fitted	30/11/2017
05/07/2017	816174	U789M	Trailer/caravan	Fail	3	Green 2 action	Brakes	Air leaks any other system	21/12/2017
05/07/2017	816174	U789M	Trailer/caravan	Fail	3	Pink sticker	Lighting	No stop lamps fitted, no stop lamps working, are excessively damaged or fully obscured. Single vehicle or rear unit of combo	21/12/2017

DL Number: s9(2)(a) Driver: s9(2)(a)

Inspection Date	CVIR Sheet Number	Plate	Vehicle Type	Inspection Result	Inspection Level	Action	Fault Category	Fault Desc	COF Expiry Date
06/07/2017	818086	PHL32	Goods van/truck/utility	Fail	5, 3	Green sticker	Exhaust System	Exhaust system not effective, loose, leaks or excessive noise	26/08/2017
06/07/2017	818086	W198L	Trailer/caravan	Fail	5, 3	Green sticker	Lighting	One side indicator system does not operate	21/08/2017

DL Number: s9(2)(a) Driver: s9(2)(a)

Inspection Date	CVIR Sheet Number	Plate	Vehicle Type	Inspection Result	Inspection Level	Action	Fault Category	Fault Desc	COF Expiry Date
17/07/2017	816188	H469A	Trailer/caravan	Pass	3	No Action			03/12/2017
17/07/2017	816188	PHL07	Goods van/truck/utility	Pass	3	No Action			16/12/2017



Inspection Date	CVIR Sheet Number	Plate	Vehicle Type	Inspection Result	Inspection Level	Action	Fault Category	Fault Desc	COF Expiry Date
01/08/2017	822421	H469A	Trailer/caravan	Fail	5, 3	Green 2 action	Brakes	Air leaks any other system	03/12/2017
01/08/2017	822421	PHL07	Goods van/truck/utility	Pass	5, 3	No Action			16/12/2017
11/10/2017	833637	H469A	Trailer/caravan	Fail	3	Green 2 action	Brakes	Air leaks any other system	03/12/2017
11/10/2017	833637	PHL07	Goods van/truck/utility	Pass	3	No Action			16/12/2017
15/11/2018	121785	9Z506	Trailer/caravan	Pass	5, 3	No Action			09/06/2019
15/11/2018	121785	PHL41	Goods van/truck/utility	Pass	5, 3	No Action			17/05/2019

DL Number: s9(2)(a) Driver: s9(2)(a)

Inspection Date	CVIR Sheet Number	Plate	Vehicle Type	Inspection Result	Inspection Level	Action	Fault Category	Fault Desc	COF Expiry Date
22/07/2017	768999	7P447	Trailer/caravan	Pass	5	No Action			12/01/2018
22/07/2017	768999	PHL37	Goods van/truck/utility	Pass	5	No Action			20/01/2018

DL Number: s9(2)(a) Driver: s9(2)(a)

Inspection Date	CVIR Sheet Number	Plate	Vehicle Type	Inspection Result	Inspection Level	Action	Fault Category	Fault Desc	COF Expiry Date
11/08/2017	822440	PHL13	Goods van/truck/utility	Fail	5, 3	Green 2 action	Brakes	Air leaks any other system	30/01/2018

DL Number: s9(2)(a) Driver: s9(2)(a)

Inspection Date	CVIR Sheet Number	Plate	Vehicle Type	Inspection Result	Inspection Level	Action	Fault Category	Fault Desc	COF Expiry Date
22/08/2017	826921	K898F	Trailer/caravan	Pass	5, 3	No Action			13/10/2017
22/08/2017	826921	PHL05	Goods van/truck/utility	Fail	5, 3	Green 2 action	Lighting	One direction Indicator lamp not working	08/11/2017
27/09/2018	097707	PHL05	Goods van/truck/utility	Fail	5, 3	Green 2 action	Lighting	One required headlamp is not fitted, not securely attached or is not operational	02/11/2018

Released under the Official Information Act 1982

Inspection Date	CVIR Sheet Number	Plate	Vehicle Type	Inspection Result	Inspection Level	Action	Fault Category	Fault Desc	COF Expiry Date
26/10/2018	105572	K898F	Trailer/caravan	Fail	5, 3	Pink sticker	Lighting	No stop lamps fitted, no stop lamps working, are excessively damaged or fully obscured. Single vehicle or rear unit of combo	13/04/2019
26/10/2018	105572	PHL05	Goods van/truck/utility	Pass	5, 3	No Action			02/05/2019
13/11/2018	114499	K898F	Trailer/caravan	Fail	5, 3	Green 2 action	Load Anchorage	Bolster not securely fitted or attachment is damaged – no immediate risk of failure	13/04/2019
13/11/2018	114499	PHL05	Goods van/truck/utility	Fail	5, 3	Pink sticker	Wheels and Tyres	Wheel nuts loose/missing or studs damaged/missing - safety risk	02/05/2019
13/11/2018	114499	PHL05	Goods van/truck/utility	Fail	5, 3	Green sticker	Brakes	Spring brake/electric brake control for parking brakes not protected from inadvertent release	02/05/2019
05/02/2019	123590	K898F	Trailer/caravan	Fail	6, 3	Green 2 action	Lighting	A rear tail lamp is not operating, damaged or fully obscured	13/04/2019
05/02/2019	123590	K898F	Trailer/caravan	Fail	6, 3	Green 2 action	Suspension	Axle locating device loose – includes loose "U" bolts	13/04/2019
05/02/2019	123590	PHL05	Goods van/truck/utility	Fail	6, 3	Green 2 action	Lighting	A headlamp is damaged failure is imminent or light output on either side is not approx equal	02/05/2019

DL Number: s9(2)(a)

Driver: s9(2)(a)

Inspection Date	CVIR Sheet Number	Plate	Vehicle Type	Inspection Result	Inspection Level	Action	Fault Category	Fault Desc	COF Expiry Date
08/09/2017	826958	L402L	Trailer/caravan	Fail	3	Pink sticker	Lighting	All side marker lamps not operational (during darkness)	13/01/2018
08/09/2017	826958	L402L	Trailer/caravan	Fail	3	Pink sticker	Lighting	A rear tail lamp is not operational (during darkness) no other rear right lamp operational	13/01/2018
08/09/2017	826958	PHL11	Goods van/truck/utility	Pass	3	No Action			13/01/2018

DL Number: s9(2)(a)

Driver: s9(2)(a)



Inspection Date	CVIR Sheet Number	Plate	Vehicle Type	Inspection Result	Inspection Level	Action	Fault Category	Fault Desc	COF Expiry Date
04/10/2017	830360	K239N	Trailer/caravan	Pass	5, 3	No Action			30/03/2018
04/10/2017	830360	PHL10	Goods van/truck/utility	Pass	5, 3	No Action			30/03/2018
30/11/2017	837267	K239N	Trailer/caravan	Fail	5, 3	Green 2 action	Lighting	Side marker lamp not operational, not secure, damaged or obscured	30/03/2018
30/11/2017	837267	PHL10	Goods van/truck/utility	Fail	5, 3	Green 2 action	Lighting	One or more front park lamps not operational (anytime)	30/03/2018
05/12/2017	839682	PHL10	Goods van/truck/utility	Fail	3	Green 2 action	Lighting	One or more front park lamps not operational (anytime)	30/03/2018

DL Number: s9(2)(a)

Driver: s9(2)(a)

Inspection Date	CVIR Sheet Number	Plate	Vehicle Type	Inspection Result	Inspection Level	Action	Fault Category	Fault Desc	COF Expiry Date
04/10/2017	832115	7K728	Trailer/caravan	Pass	5, 3	No Action			21/12/2017
04/10/2017	832115	PHL38	Goods van/truck/utility	Pass	5, 3	No Action			22/11/2017
19/02/2019	126815	7K728	Trailer/caravan	Pass	5, 3	No Action			07/06/2019
19/02/2019	126815	PHL38	Goods van/truck/utility	Pass	5, 3	No Action			22/05/2019

DL Number: s9(2)(a)

Driver: s9(2)(a)

Inspection Date	CVIR Sheet Number	Plate	Vehicle Type	Inspection Result	Inspection Level	Action	Fault Category	Fault Desc	COF Expiry Date
04/10/2017	832202	J880M	Trailer/caravan	Fail	5, 3	Pink sticker	Wheels and Tyres	A tyre is damaged – operation affected and/or failure imminent	22/12/2017
04/10/2017	832202	PHL29	Goods van/truck/utility	Pass	5, 3	No Action			21/12/2017
11/05/2018	850731	PHL29	Goods van/truck/utility	Pass	5	No Action			21/06/2018
11/05/2018	850731	U789M	Trailer/caravan	Pass	5	No Action			21/06/2018
14/11/2018	117929	PHL18	Goods van/truck/utility	Pass	5, 3	No Action			08/05/2019
14/11/2018	117929	R179F	Trailer/caravan	Pass	5, 3	No Action			24/05/2019

DL Number: s9(2)(a)

Driver: s9(2)(a)

Released under the Official Information Act 1982



Inspection Date	CVIR Sheet Number	Plate	Vehicle Type	Inspection Result	Inspection Level	Action	Fault Category	Fault Desc	COF Expiry Date
04/10/2017	832205	PHL20	Goods van/truck/utility	Pass	5, 3	No Action			06/03/2018
04/10/2017	832205	T674A	Trailer/caravan	Pass	5, 3	No Action			07/03/2018
14/11/2018	114556	6F838	Trailer/caravan	Fail	5, 3	Green 2 action	Lighting	One required rear reflector fitted, not securely fitted, colour other than red, anytime	18/01/2019
14/11/2018	114556	6F838	Trailer/caravan	Fail	5, 3	Green 2 action	Brakes	Suzie coil hose does not comply, support spring missing/ineffective	18/01/2019
14/11/2018	114556	6F838	Trailer/caravan	Fail	5, 3	Green 2 action	Ball-race Turntables	Ball-race turntable fasteners loose (other)	18/01/2019
14/11/2018	114556	6F838	Trailer/caravan	Fail	5, 3	Pink sticker	Brakes	ABS/EBS system is not operating - Combination vehicle	18/01/2019
14/11/2018	114556	PHL28	Goods van/truck/utility	Fail	5, 3	Green 2 action	Lighting	One required headlamp is not fitted, not securely attached or is not operational	18/01/2019
14/11/2018	114556	PHL28	Goods van/truck/utility	Fail	5, 3	Green 2 action	Lighting	Daytime running lamp works intermittently/operates with fog lights, not securely fitted or damaged	18/01/2019

DL Number: s9(2)(a)

Driver: s9(2)(a)

Inspection Date	CVIR Sheet Number	Plate	Vehicle Type	Inspection Result	Inspection Level	Action	Fault Category	Fault Desc	COF Expiry Date
03/10/2017	828698	J880M	Trailer/caravan	Pass	5, 3	No Action			22/12/2017
03/10/2017	828698	PHL29	Goods van/truck/utility	Pass	5, 3	No Action			21/12/2017
14/11/2017	814676	K438A	Trailer/caravan	Fail	5	Pink sticker	Lighting	No stop lamps fitted, no stop lamps working, are excessively damaged or fully obscured. Single vehicle or rear unit of combo	17/05/2018
14/11/2017	814676	PHL04	Goods van/truck/utility	Pass	5	No Action			02/05/2018
13/04/2018	850703	PHL02	Goods van/truck/utility	Fail	5	Green 2 action	Wheels and Tyres	1 wheel nut loose/missing, 1 stud damaged/missing	07/10/2018
13/04/2018	850703	R177T	Trailer/caravan	Pass	5	No Action			07/10/2018



Inspection Date	CVIR Sheet Number	Plate	Vehicle Type	Inspection Result	Inspection Level	Action	Fault Category	Fault Desc	COF Expiry Date
26/04/2018	857314	PHL02	Goods van/truck/utility	Pass	3	No Action			07/10/2018
26/04/2018	857314	R177T	Trailer/caravan	Fail	3	Green 2 action	Lighting	One required rear reflector fitted, not securely fitted, colour other than red, anytime	07/10/2018
25/06/2018	861240	PHL02	Goods van/truck/utility	Fail	3	Green sticker	Lighting	Direction indicator lamp is damaged, fully obscured or output affected/failure imminent or is not securely fitted (detachment is imminent)	07/10/2018
10/08/2018	867923	PHL02	Goods van/truck/utility	Pass	2	No Action			07/10/2018
10/08/2018	867923	R177T	Trailer/caravan	Fail	2	Green 2 action	Lighting	One direction Indicator lamp not working	07/10/2018
10/08/2018	867923	R177T	Trailer/caravan	Fail	2	Pink sticker	Load Anchorage	Sliding bolster – no locking mechanism	07/10/2018
15/11/2018	121783	PHL02	Goods van/truck/utility	Pass	5, 3	No Action			08/04/2019
15/11/2018	121783	R177T	Trailer/caravan	Fail	5, 3	Pink sticker	Wheels and Tyres	Side wall unzipping	08/04/2019
21/02/2019	126829	PHL02	Goods van/truck/utility	Pass	5, 3	No Action			08/04/2019
21/02/2019	126829	R177T	Trailer/caravan	Fail	5, 3	Green 2 action	Lighting	A rear tail lamp is not operating, damaged or fully obscured	08/04/2019
21/02/2019	126829	R177T	Trailer/caravan	Fail	5, 3	Green 2 action	Lighting	Side marker lamp not operational, not secure, damaged or obscured	08/04/2019
21/02/2019	126829	R177T	Trailer/caravan	Fail	5, 3	Pink sticker	Lighting	No stop lamps fitted, no stop lamps working, are excessively damaged or fully obscured. Single vehicle or rear unit of combo	08/04/2019
21/02/2019	126829	R177T	Trailer/caravan	Fail	5, 3	Pink sticker	Lighting	Whole indicator system does not operate	08/04/2019

DL Number: s9(2)(a)

Driver: s9(2)(a)



Inspection Date	CVIR Sheet Number	Plate	Vehicle Type	Inspection Result	Inspection Level	Action	Fault Category	Fault Desc	COF Expiry Date
03/10/2017	832193	PHL23	Goods van/truck/utility	Fail	5, 3	Green 2 action	Load Anchorage	Bolster not securely fitted or attachment is damaged – no immediate risk of failure	21/11/2017
03/10/2017	832193	Q884L	Trailer/caravan	Fail	5, 3	Green sticker	Brakes	Stroke of brake chamber exceeds manufacturer's limit - service brake performance doesn't meet legal requirements	30/10/2017
17/05/2018	850732	PHL23	Goods van/truck/utility	Pass	5	No Action			21/11/2018
03/12/2018	114599	PHL33	Goods van/truck/utility	Fail	5, 3	Green 2 action	Lighting	One required headlamp is not fitted, not securely attached or is not operational	03/04/2019
03/12/2018	114599	PHL33	Goods van/truck/utility	Fail	5, 3	Green sticker	Brakes	Spring brake/electric brake control for parking brakes not protected from inadvertent release	03/04/2019

DL Number: s9(2)(a)

Driver: s9(2)(a)

Inspection Date	CVIR Sheet Number	Plate	Vehicle Type	Inspection Result	Inspection Level	Action	Fault Category	Fault Desc	COF Expiry Date
03/10/2017	833892	M829A	Trailer/caravan	Fail	5, 3	Pink sticker	Suspension	Leaf spring or coil spring broken, missing or seriously damaged.	03/04/2018
03/10/2017	833892	PHL12	Goods van/truck/utility	Fail	5, 3	Pink sticker	Brakes	Park brake actuator missing/not operational/does not lock into position, remains applied when released, is not securely fastened & may detach. Risk of inadvertent release	24/10/2017
20/06/2018	857357	PHL32	Goods van/truck/utility	Pass	3	No Action			26/08/2018
12/11/2018	117905	PHL32	Goods van/truck/utility	Fail	5, 3	Green sticker	Exhaust System	Exhaust system not effective, loose, leaks or excessive noise	26/02/2019
12/11/2018	117905	W198L	Trailer/caravan	Fail	5, 3	Pink sticker	Brakes	ABS/EBS system is not operating - Combination vehicle	21/02/2019

DL Number: s9(2)(a)

Driver: s9(2)(a)

Released under the Official Information Act 1982





Inspection Date	CVIR Sheet Number	Plate	Vehicle Type	Inspection Result	Inspection Level	Action	Fault Category	Fault Desc	COF Expiry Date
05/10/2017	834833	PHL35	Goods van/truck/utility	Fail	5, 3	Green 2 action	Lighting	A headlamp is damaged failure is imminent or light output on either side is not approx equal	17/11/2017
05/10/2017	834833	T672A	Trailer/caravan	Fail	5, 3	Green 2 action	PSV Wheels and Tyres	Tread in dual set 1 tyre below minimum	08/11/2017
03/05/2018	854337	PHL18	Goods van/truck/utility	Pass	5, 3	No Action			08/11/2018

DL Number: s9(2)(a)

Driver: s9(2)(a)

Inspection Date	CVIR Sheet Number	Plate	Vehicle Type	Inspection Result	Inspection Level	Action	Fault Category	Fault Desc	COF Expiry Date
05/10/2017	836073	PHL22	Goods van/truck/utility	Fail	5, 3	Pink sticker	Brakes	Park brake actuator missing/not operational/does not lock into position, remains applied when released, is not securely fastened & may detach. Risk of inadvertent release	26/01/2018
05/10/2017	836073	R462K	Trailer/caravan	Pass	5, 3	No Action			26/01/2018
25/06/2018	861239	PHL20	Goods van/truck/utility	Fail	3	Green 2 action	Lighting	One direction Indicator lamp not working	07/09/2018
25/06/2018	861239	PHL20	Goods van/truck/utility	Fail	3	Green 2 action	Lighting	One required rear reflector fitted, not securely fitted, colour other than red, anytime	07/09/2018
25/06/2018	861239	PHL20	Goods van/truck/utility	Fail	3	Green 2 action	Lighting	A fog lamp is insecure, damaged or out of alignment	07/09/2018
17/08/2018	872868	9Z516	Trailer/caravan	Pass	3	No Action			24/01/2019
17/08/2018	872868	PHL43	Goods van/truck/utility	Pass	3	No Action			24/01/2019
15/11/2018	117941	9Z516	Trailer/caravan	Pass	5, 3	No Action			24/01/2019
15/11/2018	117941	PHL43	Goods van/truck/utility	Pass	5, 3	No Action			24/01/2019

DL Number: s9(2)(a)

Driver: s9(2)(a)

Released under the Official Information Act 1982



Inspection Date	CVIR Sheet Number	Plate	Vehicle Type	Inspection Result	Inspection Level	Action	Fault Category	Fault Desc	COF Expiry Date
19/10/2017	833650	K438A	Trailer/caravan	Fail	3	Pink sticker	Wheels and Tyres	A tyre is damaged – operation affected and/or failure imminent	17/11/2017
19/10/2017	833650	PHL04	Goods van/truck/utility	Fail	3	Green 2 action	Load Anchorage	Bolster not securely fitted or attachment is damaged – no immediate risk of failure	02/11/2017

DL Number: s9(2)(a) Driver: s9(2)(a)

Inspection Date	CVIR Sheet Number	Plate	Vehicle Type	Inspection Result	Inspection Level	Action	Fault Category	Fault Desc	COF Expiry Date
01/11/2017	837227	PHL36	Goods van/truck/utility	Fail	3	Green sticker	Lighting	Direction indicator lamp is damaged, fully obscured or output affected/failure imminent or is not securely fitted (detachment is imminent)	30/03/2018
18/01/2018	837646	6Y910	Trailer/caravan	Pass	5	No Action			18/01/2018
18/01/2018	837646	PHL36	Goods van/truck/utility	Pass	5	No Action			18/01/2018
13/11/2018	105599	6Y910	Trailer/caravan	Fail	5, 3	Green 2 action	Brakes	Suzie coil hose does not comply, support spring missing/ineffective	19/03/2019
13/11/2018	105599	PHL36	Goods van/truck/utility	Pass	5, 3	No Action			14/03/2019

DL Number: s9(2)(a) Driver: s9(2)(a)

Inspection Date	CVIR Sheet Number	Plate	Vehicle Type	Inspection Result	Inspection Level	Action	Fault Category	Fault Desc	COF Expiry Date
05/12/2017	839683	PHL04	Goods van/truck/utility	Pass	3	No Action			02/05/2018

DL Number: s9(2)(a) Driver: s9(2)(a)

Inspection Date	CVIR Sheet Number	Plate	Vehicle Type	Inspection Result	Inspection Level	Action	Fault Category	Fault Desc	COF Expiry Date
11/01/2018	841627	PHL16	Goods van/truck/utility	Fail	5, 3	Pink sticker	Wheels and Tyres	A tyre is damaged – operation affected and/or failure imminent	26/07/2018

Inspection Date	CVIR Sheet Number	Plate	Vehicle Type	Inspection Result	Inspection Level	Action	Fault Category	Fault Desc	COF Expiry Date
11/01/2018	841627	PHL16	Goods van/truck/utility	Fail	5, 3	Green sticker	Mudguards	One mudguard missing/does not comply or a mudflap not fitted to a twin tyred axle	26/07/2018
11/01/2018	841627	S25E	Trailer/caravan	Pass	5, 3	No Action			26/07/2018

DL Number: s9(2)(a) Driver: s9(2)(a)

Inspection Date	CVIR Sheet Number	Plate	Vehicle Type	Inspection Result	Inspection Level	Action	Fault Category	Fault Desc	COF Expiry Date
08/02/2018	843246	PHL31	Goods van/truck/utility	Fail	5	Green 2 action	Lighting	A headlamp is damaged failure is imminent or light output on either side is not approx equal	18/06/2018
08/02/2018	843246	W970G	Trailer/caravan	Pass	5	No Action			18/06/2018
30/10/2018	105582	PHL12	Goods van/truck/utility	Pass	5, 3	No Action			24/04/2019

DL Number: s9(2)(a) Driver: s9(2)(a)

Inspection Date	CVIR Sheet Number	Plate	Vehicle Type	Inspection Result	Inspection Level	Action	Fault Category	Fault Desc	COF Expiry Date
27/02/2018	854254	PHL06	Goods van/truck/utility	Pass	5, 3	No Action			26/05/2018
27/02/2018	854254	Z505Y	Trailer/caravan	Pass	5, 3	No Action			21/05/2018
08/11/2018	114485	PHL06	Goods van/truck/utility	Pass	5, 3	No Action			26/11/2018
08/11/2018	114485	Z505Y	Trailer/caravan	Pass	5, 3	No Action			21/11/2018

DL Number: s9(2)(a) Driver: s9(2)(a)

Inspection Date	CVIR Sheet Number	Plate	Vehicle Type	Inspection Result	Inspection Level	Action	Fault Category	Fault Desc	COF Expiry Date
03/04/2018	854929	PHL26	Goods van/truck/utility	Pass	3	No Action			01/08/2018
13/11/2018	117057	9Z511	Trailer/caravan	Pass	5, 3	No Action			13/01/2019
13/11/2018	117057	PHL42	Goods van/truck/utility	Pass	5, 3	No Action			13/01/2019

DL Number: s9(2)(a) Driver: s9(2)(a)



Inspection Date	CVIR Sheet Number	Plate	Vehicle Type	Inspection Result	Inspection Level	Action	Fault Category	Fault Desc	COF Expiry Date
16/04/2018	854940	P352C	Trailer/caravan	Pass	3	No Action			20/09/2018
16/04/2018	854940	PHL15	Goods van/truck/utility	Fail	3	Green 2 action	Load Anchorage	Bolster not securely fitted or attachment is damaged – no immediate risk of failure	01/09/2018

DL Number: s9(2)(a) Driver: s9(2)(a)

Inspection Date	CVIR Sheet Number	Plate	Vehicle Type	Inspection Result	Inspection Level	Action	Fault Category	Fault Desc	COF Expiry Date
25/06/2018	861241	PHL12	Goods van/truck/utility	Fail	3	Green 2 action	Lighting	One direction Indicator lamp not working	24/10/2018
25/06/2018	861241	PHL12	Goods van/truck/utility	Fail	3	Green 2 action	Lighting	One or more front park lamps not operational (anytime)	24/10/2018

DL Number: s9(2)(a) Driver: s9(2)(a)

Inspection Date	CVIR Sheet Number	Plate	Vehicle Type	Inspection Result	Inspection Level	Action	Fault Category	Fault Desc	COF Expiry Date
20/06/2018	857359	GDU506	Goods van/truck/utility	Fail	3	Green 2 action	Lighting	Daytime running lamp works intermittently/operates with fog lights, not securely fitted or damaged	06/12/2018
10/08/2018	867925	GDU506	Goods van/truck/utility	Fail	3	Green 2 action	Lighting	Daytime running lamp works intermittently/operates with fog lights, not securely fitted or damaged	06/12/2018
20/02/2019	126823	PHL06	Goods van/truck/utility	Fail	5, 3	Green 2 action	Lighting	Side marker lamp not operational, not secure, damaged or obscured	26/05/2019
20/02/2019	126823	Z505Y	Trailer/caravan	Pass	5, 3	No Action			21/05/2019

DL Number: s9(2)(a) Driver: s9(2)(a)

Released under the Official Information Act 1982



Inspection Date	CVIR Sheet Number	Plate	Vehicle Type	Inspection Result	Inspection Level	Action	Fault Category	Fault Desc	COF Expiry Date
07/07/2018	861259	7P447	Trailer/caravan	Pass	3	No Action			06/01/2019
07/07/2018	861259	PHL37	Goods van/truck/utility	Pass	3	No Action			06/01/2019
13/07/2018	861267	PHL37	Goods van/truck/utility	Fail	3	Green sticker	Mudguards	One mudguard missing/does not comply or a mudflap not fitted to a twin tyred axle	06/01/2019
14/02/2019	107362	7P447	Trailer/caravan	Pass	5, 3	No Action			01/07/2019
14/02/2019	107362	PHL37	Goods van/truck/utility	Pass	5, 3	No Action			01/07/2019

DL Number: s9(2)(a) Driver: s9(2)(a)

Inspection Date	CVIR Sheet Number	Plate	Vehicle Type	Inspection Result	Inspection Level	Action	Fault Category	Fault Desc	COF Expiry Date
17/07/2018	861276	PHL07	Goods van/truck/utility	Fail	3	Green 2 action	Lighting	Stop lamp emits colour other than red, or is obscured	16/12/2018

DL Number: s9(2)(a) Driver: s9(2)(a)

Inspection Date	CVIR Sheet Number	Plate	Vehicle Type	Inspection Result	Inspection Level	Action	Fault Category	Fault Desc	COF Expiry Date
16/08/2018	872864	M829A	Trailer/caravan	Fail	3	Green 2 action	Lighting	One required rear reflector fitted, not securely fitted, colour other than red, anytime	03/10/2018
16/08/2018	872864	PHL12	Goods van/truck/utility	Pass	3	No Action			24/10/2018

DL Number: s9(2)(a) Driver: s9(2)(a)

Inspection Date	CVIR Sheet Number	Plate	Vehicle Type	Inspection Result	Inspection Level	Action	Fault Category	Fault Desc	COF Expiry Date
17/09/2018	872898	PHL01	Goods van/truck/utility	Pass	5, 3	No Action			04/11/2018
17/09/2018	872898	Z760L	Trailer/caravan	Fail	5, 3	Pink sticker	Lighting	No stop lamps fitted, no stop lamps working, are excessively damaged or fully obscured. Single vehicle or rear unit of combo	23/10/2018

Released under the Official Information Act 1982

DL Number: s9(2)(a)

Driver: s9(2)(a)

Inspection Date	CVIR Sheet Number	Plate	Vehicle Type	Inspection Result	Inspection Level	Action	Fault Category	Fault Desc	COF Expiry Date
03/10/2018	114451	PHL30	Goods van/truck/utility	Pass	5, 3	No Action			04/03/2019
03/10/2018	114451	R443P	Trailer/caravan	Fail	5, 3	Pink sticker	Load Anchorage	Sliding bolster – no locking mechanism	02/03/2019
19/12/2018	123569	PHL30	Goods van/truck/utility	Fail	5, 3	Green 2 action	Fluid Leaks	Fluid leaks other	04/03/2019
19/12/2018	123569	R443P	Trailer/caravan	Fail	5, 3	Green 2 action	Wheels and Tyres	A tyre is damaged/imbedded object – operation not affected	02/03/2019
19/12/2018	123569	R443P	Trailer/caravan	Fail	5, 3	Pink sticker	Suspension	Suspension component not fitted/ not securely fitted	02/03/2019

DL Number: s9(2)(a)

Driver: s9(2)(a)

Inspection Date	CVIR Sheet Number	Plate	Vehicle Type	Inspection Result	Inspection Level	Action	Fault Category	Fault Desc	COF Expiry Date
13/11/2018	114496	PHL35	Goods van/truck/utility	Fail	5, 3	Green sticker	Brakes	Spring brake/electric brake control for parking brakes not protected from inadvertent release	17/05/2019
13/11/2018	114496	T672A	Trailer/caravan	Pass	5, 3	No Action			08/05/2019
21/02/2019	126828	PHL35	Goods van/truck/utility	Pass	5, 3	No Action			17/05/2019
21/02/2019	126828	T672A	Trailer/caravan	Fail	5, 3	Pink sticker	Brakes	Air brake pipe, hose, connector or component leaking - audible air leak from a pipe, hose, connector or component.	08/05/2019

DL Number: s9(2)(a)

Driver: s9(2)(a)

Inspection Date	CVIR Sheet Number	Plate	Vehicle Type	Inspection Result	Inspection Level	Action	Fault Category	Fault Desc	COF Expiry Date
14/11/2018	114553	PHL20	Goods van/truck/utility	Fail	5, 3	Green sticker	Suspension	Shock absorber missing, damaged or leaking excessively (wet or dripping)	07/03/2019

Inspection Date	CVIR Sheet Number	Plate	Vehicle Type	Inspection Result	Inspection Level	Action	Fault Category	Fault Desc	COF Expiry Date
14/11/2018	114553	PHL20	Goods van/truck/utility	Fail	5, 3	Green sticker	Brakes	Spring brake/electric brake control for parking brakes not protected from inadvertent release	07/03/2019
14/11/2018	114553	T674A	Trailer/caravan	Fail	5, 3	Green 2 action	Load Anchorage	Bolster not securely fitted or attachment is damaged – no immediate risk of failure	07/03/2019
14/11/2018	114553	T674A	Trailer/caravan	Fail	5, 3	Pink sticker	Brakes	Air leak low air pressure <30 seconds	07/03/2019
12/12/2018	107318	PHL20	Goods van/truck/utility	Pass	5, 3	No Action			07/03/2019
12/12/2018	107318	T674A	Trailer/caravan	Fail	5, 3	Pink sticker	Suspension	Air bag damaged/fully deflated – laden	07/03/2019

DL Number: s9(2)(a)

Driver: s9(2)(a)

Inspection Date	CVIR Sheet Number	Plate	Vehicle Type	Inspection Result	Inspection Level	Action	Fault Category	Fault Desc	COF Expiry Date
14/11/2018	114558	N102T	Trailer/caravan	Fail	5, 3	Green 2 action	Lighting	One direction Indicator lamp not working	30/04/2019
14/11/2018	114558	PHL14	Goods van/truck/utility	Fail	5, 3	Green 2 action	Fluid Leaks	Fluid leaks other	30/04/2019
14/11/2018	114558	PHL14	Goods van/truck/utility	Fail	5, 3	Green sticker	Brakes	Spring brake/electric brake control for parking brakes not protected from inadvertent release	30/04/2019
14/11/2018	114558	PHL14	Goods van/truck/utility	Fail	5, 3	Green sticker	Exhaust System	Exhaust system not effective, loose, leaks or excessive noise	30/04/2019

DL Number: s9(2)(a)

Driver: s9(2)(a)

Inspection Date	CVIR Sheet Number	Plate	Vehicle Type	Inspection Result	Inspection Level	Action	Fault Category	Fault Desc	COF Expiry Date
13/11/2018	117159	PHL16	Goods van/truck/utility	Pass	5, 3	No Action			26/01/2019
13/11/2018	117159	S25E	Trailer/caravan	Pass	5, 3	No Action			26/01/2019

DL Number: s9(2)(a)

Driver: s9(2)(a)



Inspection Date	CVIR Sheet Number	Plate	Vehicle Type	Inspection Result	Inspection Level	Action	Fault Category	Fault Desc	COF Expiry Date
14/11/2018	117925	PHL23	Goods van/truck/utility	Pass	5, 3	No Action			21/05/2019
14/11/2018	117925	Q884L	Trailer/caravan	Fail	5, 3	Green 2 action	Wheels and Tyres	Tyre not correctly inflated – operation/control not affected	30/04/2019
14/11/2018	117925	Q884L	Trailer/caravan	Fail	5, 3	Pink sticker	Suspension	Suspension component not fitted/ not securely fitted	30/04/2019

DL Number: s9(2)(a)

Driver: s9(2)(a)

Inspection Date	CVIR Sheet Number	Plate	Vehicle Type	Inspection Result	Inspection Level	Action	Fault Category	Fault Desc	COF Expiry Date
15/11/2018	117173	4Z305	Trailer/caravan	Pass	5, 3	No Action			01/02/2019
15/11/2018	117173	PHL26	Goods van/truck/utility	Pass	5, 3	No Action			01/02/2019
26/11/2018	114589	4Z305	Trailer/caravan	Pass	5, 3	No Action			01/02/2019
26/11/2018	114589	PHL26	Goods van/truck/utility	Pass	5, 3	No Action			01/02/2019
12/12/2018	107316	4Z305	Trailer/caravan	Pass	5, 3	No Action			01/02/2019
12/12/2018	107316	PHL26	Goods van/truck/utility	Pass	5, 3	No Action			01/02/2019

DL Number: s9(2)(a)

Driver: s9(2)(a)

Inspection Date	CVIR Sheet Number	Plate	Vehicle Type	Inspection Result	Inspection Level	Action	Fault Category	Fault Desc	COF Expiry Date
03/12/2018	123554	PHL09	Goods van/truck/utility	Pass	5, 3	No Action			25/03/2019
03/12/2018	123554	Z745L	Trailer/caravan	Pass	5, 3	No Action			24/03/2019

DL Number: s9(2)(a)

Driver: s9(2)(a)

Inspection Date	CVIR Sheet Number	Plate	Vehicle Type	Inspection Result	Inspection Level	Action	Fault Category	Fault Desc	COF Expiry Date
19/02/2019	126816	PHL01	Goods van/truck/utility	Pass	5, 3	No Action			04/05/2019
19/02/2019	126816	Z760L	Trailer/caravan	Pass	5, 3	No Action			23/04/2019

Released under the Official Information Act 1982



Total Vehicles Inspected:	184		Action	Total
Total Faults:	111		Green 2 action	49
Total Fails:	81		Pink sticker	27
Total Passes:	103		Green sticker	18
Total Fault Actions:	111		No Action	103
Average No. Faults per Vehicle:	0.60326			197
Average No. Faults per Failed Vehicle:	1.37			

Released under the Official Information Act 1982

Frequency of Faults at Roadside Inspection  
From 28/02/2017 To 27/02/2019

Operation:  
Operator: s18(c)(i) Operator Name: PACIFIC HAULAGE LIMITED  
Roadside Inspections: 103

Fault Category	Number of Faults	Percent of Vehicles
	10	9%
Brakes	24	22%
Exterior	8	7%
Lighting	52	47%
Motive	6	5%
Suspension	7	6%
Towing	2	2%
Vehicle	2	2%
<b>Total</b>	<b>111</b>	<b>100%</b>

Total Fails:	81
% of Vehicles Failed:	44.0
Total Passes:	103
% of Vehicles Passed:	56.0
No Faults Found:	#NAME!

Released under the Official Information Act 1982

Frequency of Faults identified on Failed Vehicles at Roadside Inspection  
From 28/02/2017 To 27/02/2019

Operation:  
Operator: [REDACTED]  
Roadside Inspections: 103

Operator Name: PACIFIC HAULAGE LIMITED

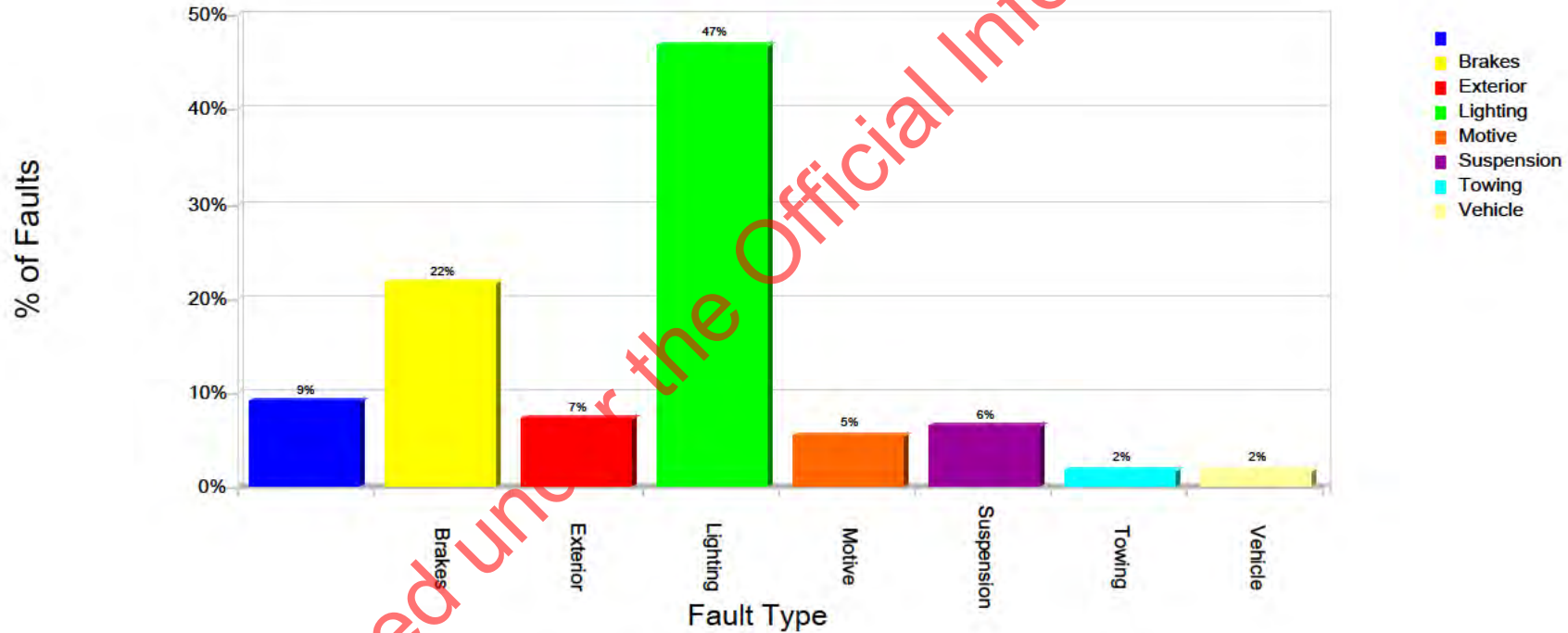

Released under the Official Information Act 1982

**Roadside Inspections Notes**  
From 28/02/2017 To 27/02/2019

Operation:

Operator: s18(c)(i)

Operator Name: PACIFIC HAULAGE LIMITED

Roadside Inspections: 103

Vehicles Inspected: 184

Vehicles with Faults: 81

TSL Number: s18(c)(i)

Operator: PACIFIC HAULAGE LIMITED

Inspection Date/Time	Driver	DL Number	Plate	Vehicle Details	Notes
07/03/17 16:45	s9(2)(a)		M829A	2008 KRAFT 404	Additional Notes Log Book Page: RTF 432703-29  DEFECT INFORMATION FAULT 1: Indicator to operate.
07/03/17 16:45			PHL12	2008 KENWORTH T	Additional Notes Log Book Page: RTF 432703-29  DEFECT INFORMATION FAULT 1: Indicator to operate.
14/03/17 09:56			5W717	2016 KRAFT 400	Additional Notes Log Book Page: RTFNZ 20324-1
14/03/17 09:56			PHL27	2016 KENWORTH T	Additional Notes Log Book Page: RTFNZ 20324-1
15/03/17 11:21			PHL06	2014 KENWORTH T	DEFECT INFORMATION FAULT 1: Top shock bolt loose.  Additional Notes Log Book Page: Rtfnz2034333.
15/03/17 11:21			Z505Y	2014 KRAFT 404	DEFECT INFORMATION FAULT 1: Top shock bolt loose.  Additional Notes Log Book Page: Rtfnz2034333.
03/04/17 11:15			PHL15	2009 KENWORTH T	
11/04/17 09:22			PHL01	2014 KENWORTH T	

01/03/2019 08:28:52



1982



Inspection Date/Time	Driver	DL Number	Plate	Vehicle Details	Notes
11/04/17 09:22	s9(2)(a)		Z760L	2014 KRAFT 404	
16/05/17 14:31			PHL34	2014 KENWORTH T	
16/05/17 14:31			Y951K	2014 KRAFT 404	
17/05/17 14:52			PHL35	2014 KENWORTH T	
17/05/17 14:52			T672A	2012 KRAFT 400	
31/05/17 10:53			7B837	2017 KRAFT 400	
31/05/17 10:53			PHL25	2017 KENWORTH T	
15/06/17 07:41			PHL35	2014 KENWORTH T	
15/06/17 12:15			L402L	2008 KRAFT 404	
15/06/17 12:15			PHL11	2008 KENWORTH T	
04/07/17 12:31			PHL35	2014 KENWORTH T	
04/07/17 12:31			T672A	2012 KRAFT 400	
05/07/17 10:33			PHL08	2016 KENWORTH T	
05/07/17 10:33			U789M	2013 KRAFT 404	
06/07/17 07:00			PHL32	2013 KENWORTH T	
06/07/17 07:00			W198L	2013 KRAFT 404	
17/07/17 06:50			H469A	2006 EVANS 4AC	
17/07/17 06:50			PHL07	2009 KENWORTH T	
22/07/17 11:18			7P447	2017 KRAFT 400	
22/07/17 11:18			PHL37	2017 KENWORTH T	
01/08/17 13:49			H469A	2006 EVANS 4AC	
01/08/17 13:49			PHL07	2009 KENWORTH T	
11/08/17 08:05			PHL13	2001 KENWORTH K104	
22/08/17 16:24			K898F	2007 KRAFT 400	
22/08/17 16:24			PHL05	2007 KENWORTH T	
05/09/17 12:25			PHL35	2014 KENWORTH T	
05/09/17 12:25			T672A	2012 KRAFT 400	
08/09/17 05:59			L402L	2008 KRAFT 404	
08/09/17 05:59			PHL11	2008 KENWORTH T	
11/09/17 06:36			PHL01	2014 KENWORTH T	
03/10/17 10:12			PHL23	2010 KENWORTH T408	
03/10/17 10:12			Q884L	2010 KRAFT 404	
03/10/17 10:22			J880M	2001 EVANS 4AS	
03/10/17 10:22			PHL29	2010 KENWORTH K108	

Released under the Official Information Act 1982



Inspection Date/ Time	Driver	DL Number	Plate	Vehicle Details	Notes
03/10/17 12:15	s9(2)(a)		M829A	2008 KRAFT 404	
03/10/17 12:15			PHL12	2008 KENWORTH T	
03/10/17 14:18			7B837	2017 KRAFT 400	
03/10/17 14:18			PHL25	2017 KENWORTH T	
03/10/17 14:52			5W717	2016 KRAFT 400	
03/10/17 14:52			PHL27	2016 KENWORTH T	
04/10/17 07:24			J880M	2001 EVANS 4AS	
04/10/17 07:24			PHL29	2010 KENWORTH K108	
04/10/17 08:32			PHL20	2012 KENWORTH K108	
04/10/17 08:32			T674A	2012 KRAFT 404	
04/10/17 11:06			GDU506	2011 KENWORTH T	
04/10/17 11:06			S532N	2011 KRAFT 404	
04/10/17 13:14			7K728	2017 KRAFT 400	
04/10/17 13:14			PHL38	2017 KENWORTH T	
04/10/17 15:36			K239N	2007 KRAFT 404	
04/10/17 15:36			PHL10	2007 KENWORTH T	
05/10/17 08:30			PHL35	2014 KENWORTH T	
05/10/17 08:30			T672A	2012 KRAFT 400	
05/10/17 14:48			PHL22	2011 KENWORTH K	
05/10/17 14:48			R462K	2011 KRAFT 404	
11/10/17 07:38			H469A	2006 EVANS 4AC	
11/10/17 07:38			PHL07	2009 KENWORTH T	
19/10/17 10:53			K438A	2007 KRAFT 404	
19/10/17 10:53			PHL04	2007 KENWORTH K104	
01/11/17 06:11			PHL36	2017 KENWORTH T	
02/11/17 11:00			5W717	2016 KRAFT 400	
02/11/17 11:00			PHL27	2016 KENWORTH T	
14/11/17 10:02			K438A	2007 KRAFT 404	
14/11/17 10:02			PHL04	2007 KENWORTH K104	
30/11/17 13:58			K239N	2007 KRAFT 404	
30/11/17 13:58			PHL10	2007 KENWORTH T	
05/12/17 02:57			PHL10	2007 KENWORTH T	
05/12/17 03:32			PHL04	2007 KENWORTH K104	
11/01/18 14:18			PHL16	2011 KENWORTH K108	

Released under the Official Information Act 1982



1982



Inspection Date/ Time	Driver	DL Number	Plate	Vehicle Details	Notes
11/01/18 14:18	s9(2)(a)		S25E	2011 KRAFT 404	
18/01/18 12:10			PHL36	2017 KENWORTH T	
18/01/18 12:10			6Y910	2017 KRAFT 400	
08/02/18 10:31			PHL31	2013 KENWORTH T	
08/02/18 10:31			W970G	2013 KRAFT 404	
27/02/18 06:53			PHL06	2014 KENWORTH T	
27/02/18 06:53			Z505Y	2014 KRAFT 404	
03/04/18 13:39			PHL26	2016 KENWORTH T	
13/04/18 07:03			PHL02	2011 KENWORTH K108	
13/04/18 07:03			R177T	2011 KRAFT 404	
16/04/18 07:04			PHL15	2009 KENWORTH T	
16/04/18 07:04			P352C	2009 KRAFT 404	
26/04/18 07:42			PHL02	2011 KENWORTH K108	
26/04/18 07:42			R177T	2011 KRAFT 404	
03/05/18 07:38			PHL18	2010 KENWORTH T	ADDITIONAL NOTES: 508482,
11/05/18 07:13			U789M	2013 KRAFT 404	
11/05/18 07:13			PHL29	2010 KENWORTH K108	
17/05/18 11:50			PHL23	2010 KENWORTH T408	
20/06/18 06:05			PHL32	2013 KENWORTH T	
20/06/18 08:29			PHL27	2016 KENWORTH T	
20/06/18 09:48			GDU506	2011 KENWORTH T	
25/06/18 14:35			PHL20	2012 KENWORTH K108	
25/06/18 15:08			PHL02	2011 KENWORTH K108	
25/06/18 15:32			PHL12	2008 KENWORTH T	
07/07/18 06:40			7P447	2017 KRAFT 400	
07/07/18 06:40			PHL37	2017 KENWORTH T	
13/07/18 10:47			PHL37	2017 KENWORTH T	
17/07/18 12:02			PHL07	2009 KENWORTH T	
10/08/18 07:00			PHL02	2011 KENWORTH K108	
10/08/18 07:00			R177T	2011 KRAFT 404	
10/08/18 12:04			GDU506	2011 KENWORTH T	
16/08/18 10:08			M829A	2008 KRAFT 404	
16/08/18 10:08			PHL12	2008 KENWORTH T	
17/08/18 07:17			9Z516	2018 KRAFT 505	

Released under the Official Information Act 1982



Inspection Date/ Time	Driver	DL Number	Plate	Vehicle Details	Notes
17/08/18 07:17	s9(2)(a)		PHL43	2018 KENWORTH T	
17/09/18 14:10		PHL01	2014 KENWORTH T		
17/09/18 14:10		Z760L	2014 KRAFT 404		
27/09/18 11:57		PHL05	2007 KENWORTH T		
03/10/18 07:28		PHL30	2011 KENWORTH K		
03/10/18 07:28		R443P	2011 KRAFT 404		
26/10/18 13:22		K898F	2007 KRAFT 400		
26/10/18 13:22		PHL05	2007 KENWORTH T		
30/10/18 02:41		PHL12	2008 KENWORTH T		
08/11/18 13:52		PHL06	2014 KENWORTH T		
08/11/18 13:52		Z505Y	2014 KRAFT 404		
12/11/18 12:03		PHL32	2013 KENWORTH T		
12/11/18 12:03		W198L	2013 KRAFT 404		
13/11/18 05:44		9Z511	2018 KRAFT 505		
13/11/18 05:44		PHL42	2018 KENWORTH T		
13/11/18 07:10		PHL16	2011 KENWORTH K108		
13/11/18 07:10		S25E	2011 KRAFT 404		
13/11/18 08:45		PHL35	2014 KENWORTH T		
13/11/18 08:45		T672A	2012 KRAFT 400		
13/11/18 08:48		PHL36	2017 KENWORTH T		
13/11/18 08:48		6Y910	2017 KRAFT 400		
13/11/18 13:26		K898F	2007 KRAFT 400		
13/11/18 13:26		PHL05	2007 KENWORTH T		
14/11/18 07:40		PHL23	2010 KENWORTH T408		
14/11/18 07:40		Q884L	2010 KRAFT 404		
14/11/18 08:18		PHL20	2012 KENWORTH K108		
14/11/18 08:18		T674A	2012 KRAFT 404		
14/11/18 09:41		6F838	2017 KRAFT 400		
14/11/18 09:41		PHL28	2017 KENWORTH T		
14/11/18 11:06		PHL18	2010 KENWORTH T		
14/11/18 11:06		R179F	2011 KRAFT 404		
14/11/18 11:46		N102T	2009 KRAFT 404		
14/11/18 11:46	PHL14	2009 KENWORTH K108			
15/11/18 07:13	PHL26	2016 KENWORTH T			

Released under the Official Information Act 1982





Inspection Date/Time	Driver	DL Number	Plate	Vehicle Details	Notes
15/11/18 07:13	s9(2)(a)		4Z305	2016 KRAFT 404	
15/11/18 08:43			5W717	2016 KRAFT 400	
15/11/18 08:43			PHL27	2016 KENWORTH T	
15/11/18 10:58			PHL34	2014 KENWORTH T	
15/11/18 10:58			Y951K	2014 KRAFT 404	
15/11/18 13:26			9Z506	2018 KRAFT 507	
15/11/18 13:26			PHL41	2018 KENWORTH T	
15/11/18 13:48			PHL02	2011 KENWORTH K108	
15/11/18 13:48			R177T	2011 KRAFT 404	
15/11/18 13:52			9Z516	2018 KRAFT 505	
15/11/18 13:52			PHL43	2018 KENWORTH T	
26/11/18 05:59			PHL26	2016 KENWORTH T	
26/11/18 05:59			4Z305	2016 KRAFT 404	
03/12/18 06:09			PHL33	2013 KENWORTH T	
03/12/18 10:46			PHL09	2014 KENWORTH T	
03/12/18 10:46			Z745L	2014 KRAFT 404	
12/12/18 06:46			PHL26	2016 KENWORTH T	
12/12/18 06:46			4Z305	2016 KRAFT 404	
12/12/18 07:31			PHL20	2012 KENWORTH K108	
12/12/18 07:31			T674A	2012 KRAFT 404	
13/12/18 10:20			7B837	2017 KRAFT 400	
13/12/18 10:20			PHL25	2017 KENWORTH T	
18/12/18 15:07			PHL13	2017 KENWORTH T	
18/12/18 15:07			8K642	2017 KRAFT 404	
19/12/18 07:48			PHL30	2011 KENWORTH K	
19/12/18 07:48			R443P	2011 KRAFT 404	
05/02/19 15:26			K898F	2007 KRAFT 400	
05/02/19 15:26			PHL05	2007 KENWORTH T	
14/02/19 15:28			7R447	2017 KRAFT 400	
14/02/19 15:28			PHL37	2017 KENWORTH T	
19/02/19 06:27			7K728	2017 KRAFT 400	
19/02/19 06:27			PHL38	2017 KENWORTH T	
19/02/19 07:27			PHL01	2014 KENWORTH T	
19/02/19 07:27			Z760L	2014 KRAFT 404	

Released under the Official Information Act 1982



Inspection Date/ Time	Driver	DL Number	Plate	Vehicle Details	Notes
20/02/19 06:51	s9(2)(a)		PHL06	2014 KENWORTH T	
20/02/19 06:51			Z505Y	2014 KRAFT 404	
21/02/19 05:54			PHL35	2014 KENWORTH T	
21/02/19 05:54			T672A	2012 KRAFT 400	
21/02/19 06:27			PHL02	2011 KENWORTH K108	
21/02/19 06:27			R177T	2011 KRAFT 404	

Released under the Official Information Act 1982

**Details**

**Date:** Wednesday 27 February 2019      **Time:** 05:56      **Police QID/NZTA ID:** RBC411, PNIQ51  
**Location:** Awapuni Road, Awapuni  
**Direction:** E      **Area:** 3      **GPS:** -38.66881627593065, 178.0007574243266  
**Inspection Level:** 3, 5, Wgt

**Driver**

**DLICNO:** s9(2)(a)      **DOB:** s9(2)(a)  
**Name:** s9(2)(a)      **Class:** 6, 4, 3, 5, 1, 2  
**Address:** s9(2)(a)      **Endorsed:** F, R, T, W  
**Ph:**      **Cell:** s9(2)(a)

**Operator**

**TSL:** s18(c)      **Fleet #:** 26      **Ph:**      **Cell:**  
**Name:** PACIFIC HAULAGE LIMITED  
**Address:**  
**Contracted To:**

**Vehicle(s)**

**Over Dimension Permit:** No  
**Loaded:** Yes - Logs

	(A)	(B)	(C)	(D)
<b>Reg#:</b>	PHL26	4Z305		
<b>Vehicle Type:</b>	Truck	Full Trailer		
<b>Make/Model:</b>	Kenworth	Kraft		
<b>COF Expiry:</b>	26/07/2019	26/07/2019		
<b>L/Label Expiry:</b>	02/08/2019	11/08/2019		
<b>GVM:</b>				
<b>GCM:</b>				
<b>Tare:</b>				
<b>Axle Rating Front:</b>				
<b>Axle Rating Rear:</b>				
<b>ODO:</b>	177981 KM			
<b>Defects Found:</b>		Yes		
<b>Action Taken:</b>		Verbal Direction		
<b>RuL#:</b>	596146808	595829425		
<b>Type:</b>	H94	951		
<b>Wgt:</b>	50			
<b>Max Distance:</b>	241000	129000		
<b>Distance Recorder:</b>	239522	128367		
<b>Hub Make:</b>	Ibright	Data Trac Pro		
<b>Hub Serial:</b>	51/1625270136	12/10817		
<b>Tyre Size:</b>				
<b>Hubo Size:</b>				
<b>Additional RUC:</b>				
<b>RuL#:</b>				
<b>Type:</b>				
<b>Wgt:</b>				
<b>Max Distance:</b>				

**Defects**

B	4Z305	SS61 - Shock absorber missing, damaged or leaking excessively (wet or dripping) 1 x Axle LH shocker Leaking	Left Front	Green Sticker
---	-------	--	------------	---------------

**Weight**

**Overweight Permit:** Yes - 50MAX- HPMV-18-19327

	L	R	Total	Spacing	Permit
(A)	S				
	S		8860	1.9	
	T			6.09	
	T		16630	7.41	
	<b>Vehicle Gross Weight</b>		25490		0
(B)	T			12.51	
	T			13.76	
	T			17.59	
	T			18.85	
	T		25280	20.1	
	<b>Vehicle Gross Weight</b>		25280		0
	<b>Gross Weight</b>		50770		

**Axle Groups**

Group	Axles	Total Weight	Spacing
-------	-------	--------------	---------

**Additional Notes**

**Log Book Page:** PHL 000317-21

**Driver Notes:**

**Contact Details**

NZ Police Commercial Vehicle Safety Team

CVST Ohakea  
PO Box 1  
Sanson 4862  
Ph 06 329 3594  
Fax 06 329 3562  
Email cvst3@police.govt.nz

**Details**

**Date:** Friday 8 February 2019      **Time:** 10:32      **Police QID/NZTA ID:** RBC411, PNIQ51  
**Location:** Waiatai Valley Road  
**Direction:** E      **Area:** 3      **GPS:** -39.023589757307455, 177.4114156702323  
**Inspection Level:** 3, 5

**Driver**

**DLICNO:** s9(2)(a)      **DOB:** s9(2)(a)  
**Name:** s9(2)(a)      **Class:** 5, 4, 6, 2, 1, 3  
**Address:** s9(2)(a)      **Endorsed:** R, T, W  
**Ph:** s9(2)(a)      **Cell:**

**Operator**

**TSL:** s18(c)      **Fleet #:** 15      **Ph:**      **Cell:**  
**Name:** PACIFIC HAULAGE LIMITED  
**Address:**  
**Contracted To:**

**Vehicle(s)**

**Over Dimension Permit:** No  
**Loaded:** Yes - Logs

	(A)	(B)	(C)	(D)
<b>Reg#:</b>	PHL15	P352C		
<b>Vehicle Type:</b>	Truck	Full Trailer		
<b>Make/Model:</b>	Kenworth	Kraft		
<b>COF Expiry:</b>	01/03/2019	22/03/2019		
<b>L/Label Expiry:</b>	26/08/2019	31/08/2019		
<b>GVM:</b>				
<b>GCM:</b>				
<b>Tare:</b>				
<b>Axle Rating Front:</b>				
<b>Axle Rating Rear:</b>				
<b>ODO:</b>				
<b>Defects Found:</b>				
<b>Action Taken:</b>				
<b>RuL#:</b>	595202681	594579522		
<b>Type:</b>	14	43		
<b>Wgt:</b>	26			
<b>Max Distance:</b>	425001	291000		
<b>Distance Recorder:</b>	422880	289096		
<b>Hub Make:</b>	Ibright	Data Trac Pro		
<b>Hub Serial:</b>	51/1413240077	8/526980		
<b>Tyre Size:</b>				
<b>Hubo Size:</b>				
<b>Additional RUC:</b>				
<b>RuL#:</b>				
<b>Type:</b>				
<b>Wgt:</b>				
<b>Max Distance:</b>				

**Weight**

**Overweight Permit:** No

	L	R	Total	Spacing	Permit
(A)	S				
	S		8950	1.9	
	T			5.79	
	T		15670	7.11	
	<b>Vehicle Gross Weight</b>		24620		
(B)	T			11.07	
	T			12.31	
	T			16.65	
	T		22250	17.9	
	<b>Vehicle Gross Weight</b>		22250		
	<b>Gross Weight</b>		46870		

**Axle Groups**

Group	Axles	Total Weight	Spacing
-------	-------	--------------	---------

**Additional Notes**

**Log Book Produced:**

**Log Book Page:** PHL 000318-09

**Log Book Not Produced Reason:**

**Driver Notes:**

**Contact Details**

NZ Police Commercial Vehicle Safety Team

CVST Ohakea  
PO Box 1  
Sanson 4862  
Ph 06 329 3594  
Fax 06 329 3562  
Email cvst3@police.govt.nz



# Fines Summary

As at: 05/03/2019

Central Registry (CPU)

**Pacific Haulage Limited**

PO Box 2126  
Gisborne

**PPN** 1593008106

**DOB**

CCN	CRN	Offence Date	Offence	Vehicle Registration	Date Imposed	Total Amount Imposed	Status	Enforcement/Arrangement Type	Reparation Remaining	Current Balance
1500796131	92016007155	09/06/1992	Operator Exc Gross Wgt On Distance L		19/08/1992	\$215.00	Closed		\$0.00	\$0.00
1500796130	92016007154	09/06/1992	Exceed Wt Lmt 2/More Axls-not Tandm/		19/08/1992	\$165.00	Closed		\$0.00	\$0.00
1500796422	92016008276	12/08/1992	Operator Exc Gross Wgt On Distance L		26/10/1992	\$415.00	Closed		\$0.00	\$0.00
1500796423	92016008277	12/08/1992	Operator Exc Gross Wgt On Distance L		26/10/1992	\$415.00	Closed		\$0.00	\$0.00
1500796421	92016008275	12/08/1992	Exceeding Maximum Gross Weight		26/10/1992	\$615.00	Closed		\$0.00	\$0.00
1500796420	92016008274	12/08/1992	Exceed Wt Lmt 2/More Axls-not Tandm/		26/10/1992	\$1,265.00	Closed		\$0.00	\$0.00
1500796584	92016008802	23/09/1992	Inaccurate Recording Hubodometer (Ow		18/01/1993	\$1,095.00	Closed		\$0.00	\$0.00
1501030891	93016005142	08/03/1993	Inaccurate Recording Hubodometer (Ow		08/06/1993	\$845.00	Closed		\$0.00	\$0.00
1526950012	10016104737	19/05/2010	Exceeding Maximum Gross Weight	PHL13	02/08/2010	\$180.00	Satisfied		\$0.00	\$0.00
1529624878	11016105660	10/05/2011	Exceeds Gross Weight Distance Licenc	L402L	27/07/2011	\$230.67	Satisfied		\$0.00	\$0.00
1529624347	11016105617	10/05/2011	Exceeding Maximum Gross Weight	PHL11	27/07/2011	\$930.67	Satisfied		\$0.00	\$0.00
1529624400	11016105618	10/05/2011	Exceed Wt Lmt 2/More Axls-not Tandm/	PHL11	27/07/2011	\$380.67	Satisfied		\$0.00	\$0.00
<b>Total for cases listed:</b>									\$0.00	\$0.00

**Total outstanding for PPN 1593008106**      **\$0.00**

**Last payment made: 05/08/2011**

Released under the Official Information Act 1982

30<sup>th</sup> March 2019

Pacific Haulage Limited  
107 Aerodrome Road  
Matawhero  
GISBORNE

To s9(2)(a)

**Notice of Audit**

Section 198 Land Transport Act 1998 (PART A)

**PART A**

Pursuant to section 198 of the Land Transport Act 1998, the NZ Transport Agency (the Agency) may, in writing, require any person who holds a land transport document that authorises the provision of a service in the land transport system to undergo such inspections and audits as the Agency reasonably considers necessary in the interests of land transport safety.

The Agency may require any information that it reasonably considers to be relevant to the inspection or audit.

A person who is required by the Agency to provide information under section 198 must comply with that requirement, and there is a related offence in section 51 of the Land Transport Act 1998 for failing or refusing (without reasonable excuse) to comply with a requirement in relation to an audit or inspection.

Relevant sections of the Land Transport Act 1998 are attached at **Appendix 1** for your information.

You are hereby advised of the Agency's intention to conduct an audit of the vehicles and respect of the transport services provided under the Transport Service Licence (TSL) number S18(C) issued in the name Pacific Haulage Limited. (i)

In order to facilitate the audit, **you are required to provide the following information:**

1. Copies of current employment and/or contractual agreements for the following drivers:

s9(2)(a)

2. All documentation relating to traffic offending, work time and/or logbook breaches for all drivers for the 3 month period from 10<sup>th</sup> December 2019 to 10<sup>th</sup> March 2019 inclusive.



3. All documentation relating to drug testing of all drivers for the 12 month period ending Sunday 10<sup>th</sup> of March 2019, including but not limited to requests for testing, results from testing and employment action taken as a result of test results. This is also to include all testing undertaken for the purpose of pre-employment for all tested persons.
4. All or any documentation, whether written or electronically recorded by drivers for the purpose of daily vehicle pre-deployment checks for all vehicles operated by Pacific Haulage Limited, TSL s18(c)(i) for a one month period from Monday 11<sup>th</sup> February 2019 to Sunday 10<sup>th</sup> of March 2019 inclusive.
5. All vehicle maintenance records for vehicles operated by Pacific Haulage Limited, TSL s18(c)(i), including but not limited to fault sheets, job sheets or cards, service and maintenance records, check sheets and reports from 11<sup>th</sup> February 2019 to Sunday 10<sup>th</sup> of March 2019 inclusive. Invoices provided by s9(2)(b)(ii) previously submitted are to be excluded.

All items must be sent to the Agency either in person or by courier to NZTA, Level 2, 50 Victoria Street, Wellington, Attention Nathan Murrell or via email to nathan.murrell@nzta.govt.nz by 5pm **on \*\*\*day the \*st of June 2019.**

Please be advised that failing or refusing to comply with any requirements of sections 30ZD or 30ZH is an offence under sections 79N and 79Q of the Land Transport Act 1998.

Yours Sincerely

Nathan Murrell

Commercial Transport Officer

Released under the Official Information Act 1982

## Appendix 1

### LAND TRANSPORT ACT 1998

#### **198 Inspections and audits**

- (1) The Agency may in writing require any person who holds a land transport document that authorises the provision of a service in the land transport system to undergo such inspections and audits as the Agency reasonably considers necessary in the interests of land transport safety (including inspections and audits of vehicles operated by such persons).
- (2) The Agency may carry out such inspections and audits as the Agency reasonably considers necessary in the interests of land transport safety.
- (3) For the purposes of any inspection or audit carried out in respect of any person under this section, the Agency may in writing require that person to provide such information as the Agency reasonably considers relevant to the inspection or audit.
- (4) A person to whom a requirement is made under this section must comply with that requirement.

#### **51 Contravention of section 198(4)**

- (1) A person commits an offence if the person, without reasonable excuse, fails or refuses to comply with a requirement made under section 198 in relation to an audit or inspection.
- (2) The maximum penalty on conviction for an offence against subsection (1) is a fine not exceeding \$5,000.

#### **30A Requirements for vehicles**

- (1) A holder of a transport service licence must ensure that—
  - (a) every vehicle to be used in the service is maintained in a fit and proper condition and that the requirements of any Act, regulation, or rule made for this purpose are met;
  - (b) no vehicle is used in the service unless and until all fees payable in respect of the vehicle and the service under any Act, regulation, or bylaw have been duly paid or appropriate arrangements have been made for payment.
- (2) The holder of any transport service licence must, whenever required to do so by the Agency, present for inspection any transport service vehicle used in the service.
- (2A) The driver of a small passenger service vehicle must, whenever required to do so by the Agency, present the vehicle for inspection.
- (3) No evidence of vehicle inspection may be issued in respect of a transport service vehicle unless the person issuing the evidence of vehicle inspection has been notified of the transport service licence number under which the vehicle is being operated.
- (4) No person may use a transport service vehicle if that vehicle has suffered serious damage until the vehicle has been inspected and passed as being safe by a person authorised by the Agency, or the owner of the vehicle has been informed by such a person that the vehicle is not to be inspected.
- (5) Nothing in subsection (1), (3), or (4) applies to a vehicle used in a small passenger service.
- (6) Nothing in this section applies to—
  - (a) the facilitator of a facilitated cost-sharing arrangement; or
  - (b) a vehicle used in a facilitated cost-sharing arrangement; or
  - (c) a vehicle designed or adapted to carry 12 or fewer persons (including the driver) provided by one of the passengers being carried.

#### **30ZD Records must be kept**

- (1AA) Subsection (1) applies to—
  - (a) a person who employs a person to drive a vehicle referred to in section 30ZB; and
  - (b) a self-employed driver who drives a vehicle referred to in section 30ZB; and

- (c) a facilitator who facilitates a driver who drives a vehicle referred to in section 30ZB to connect with passengers.
- (1) A person to whom this section applies must keep all—
  - (a) time records, records of payments to the driver, and employment or contractual records relating to the driver; and
  - (b) accommodation records and receipts for the driver that are relevant to the driver's transport service or transport service vehicle; and
  - (c) fuel records and receipts for the relevant transport service vehicles.
- (2) The person who keeps the records required under subsection (1) must—
  - (a) keep each record for 12 months from the date it is made; and
  - (b) make all relevant records referred to in subsection (1) in the possession or control of that person available for immediate inspection on demand at any reasonable time by an enforcement officer.
- (3) Every enforcement officer to whom records are made available for inspection under subsection (2)(b) is entitled to make copies of those records.

**79N Failure to keep or produce records or comply with conditions of exemption or approval**

Every person commits an offence who fails or refuses to comply with any of the requirements of section 30ZD or the conditions of any exemption granted or approval given under section 30ZA(1)(a) or (c), and is liable on conviction,—

- (a) in the case of a driver, to a fine not exceeding \$2,000, and the person may, for a period of 1 calendar month or such greater period as the court thinks fit, be disqualified from holding or obtaining a licence to drive any vehicle that—
  - (i) requires a class 2, 3, 4, or 5 licence (as specified in the rules); or
  - (ii) is used in the relevant transport service; or
  - (iii) is used to carry goods for hire or reward; or
- (b) in any other case, to a fine not exceeding \$100,000.

**30ZH Duties regarding logbooks**

- (1) A driver must—
  - (a) retain a logbook required to be maintained by that driver under section 30ZF for a period of 12 months after the date of the last entry in that logbook; and
  - (b) in the case of a driver who is an employee, or who is driving on behalf of a transport service operator, or who is facilitated to connect with passengers by a small passenger service operator, deliver a copy of each completed logbook record to the driver's employer or transport service operator within 14 days after completing that record, and the employer or transport service operator must retain the copy of each logbook record for a period of 12 months from the date of the record.
- (1A) Despite anything in subsection (1), if the logbook only contains entries for a light RUC vehicle (as defined in section 5(1) of the Road User Charges Act 2012), the driver must retain the logbook only for a period of 12 months.
- (2) A driver must—
  - (a) carry a logbook with him or her at all times when driving a vehicle to which section 30ZE applies; and
  - (b) produce, on demand by any enforcement officer and without delay, any logbook that—
    - (i) the driver is required to maintain; and
    - (ii) relates to—
      - (A) the day of the driver's last rest time of at least 24 hours; and
      - (B) all the days since that rest time.
- (3) If the form of the logbook required to be maintained under section 30ZF includes an identical copy made simultaneously with the original of that logbook, and the logbook has been produced to an enforcement officer, that enforcement officer is entitled, on demand,—
  - (a) to remove that identical copy; or
  - (b) if that identical copy has previously been removed or is illegible, to make a copy of that logbook.

- (4) A person who is required to retain a logbook or a copy of a logbook under subsection (1) must make it and all relevant time records, records of payments to the driver, and employment or contractual records relating to the driver available for immediate inspection on demand by an enforcement officer at any reasonable time during the period for which it is required to be retained.
- (5) A person to whom a logbook or a copy of a logbook or records are required to be made available for inspection under subsection (4) is entitled to make a copy of that logbook or that copy or those records.

**79Q Failure to discharge duties regarding logbooks**

Every person who fails or refuses to comply with any requirement of or demand made under section 30ZH commits an offence and is liable on conviction,—

- (a) in the case of a driver, to a fine not exceeding \$2,000, and the person may, for a period of 1 calendar month or any greater period that the court thinks fit, be disqualified from holding or obtaining a licence to drive any vehicle that—
  - (i) requires a class 2, 3, 4, or 5 licence (as specified in the rules); or
  - (ii) is used in the relevant transport service; or
  - (iii) is—
    - (A) a heavy motor vehicle; and
    - (B) used to carry goods for hire or reward:
- (b) in any other case, to a fine not exceeding \$25,000.

**113A Power to inspect records**

- (1) For the purpose of ascertaining whether this Act has been or is being complied with by any person to whom this Act applies, any enforcement officer in uniform or in possession of a warrant or other evidence of his or her authority as an enforcement officer may require that person to produce without delay for inspection all relevant books or records in that person's possession or over which that person has control, including (but not limited to) records kept under section 65 of the Road User Charges Act 2012, logbooks, records associated with logbooks, financial records relating to expenditure on fuel, invoices, vehicle maintenance records, depreciation records for vehicles, time and wage records, and waybills.
- (2) The enforcement officer may take extracts from or make copies of any books or records so produced.

Released under the Official Information Act 1982



**To** Rob Montgomery  
Manager Road Compliance

**From** Nathan Murrell  
Commercial Transport Officer

**Date** 20<sup>th</sup> February 2019

**Subject** Pacific Haulage Limited  
s18(c)(i)  
s18(c)(i)

A desktop review of s9(2)(b)(ii) is completed and the following is a summary of my findings with my recommendation.

(1) TSL Information

**Name:** Pacific Haulage Limited  
**Address:** 107 Aerodrome Road, Matawhero, Gisborne 4071  
**Director/COKLP:** Calvin John Paddon

(2) NZ Companies Office

**Directors:** Calvin John Paddon & Warwick Kenneth Wilshier  
**Shareholdings:** Calvin John Paddon, s9(2)(a) Wilshier Management Limited

(3) Previous History

09.11.12 - ION issued for "Not up to COF Standard" as part of "Operation Rattle".  
28.05.13 - ORS visit made 27.02.13 and information given out.  
11.12.13 - ION issued for "Not up to COF Standard" as part of "Operation Rattle".  
02.05.14 - Relationship visit made to discuss TOH with individual drivers in conjunction with CVST.  
Issues discussed around safety of fleet drivers.  
02.09.14 - Updated company with WIM data and discussed lack of work.

(4) Traffic Offence History & Demerit Points

- Company:** Last 2 years 9 x Not up to COF Standard, 4 x Exceeds Maximum Gross Mass Limits, 3 x Excess Speed, 1 x Wheel Not Securely Attached to Hub, 1 x Exceed Mass On 2 Axles in Tandem Set - HPMV,  
1 x Failed to Comply with HPMV Permit Conditions - Mass, 1 x Inadequate Mudguards Twin Tyred Rear Axle, 1 x Operate Overlength Towing Vehicle, 1 x Unsafe Loading, 1 x Operated a Vehicle With Damaged Tyre, 1 x Overdimension Vehicle Breached Requirements
- Persons in control:** Last 2 years - no offences committed. Paddon has 6 historical speed related offences between 1986 and 2009.

(5) **Criminal History**

A criminal history report for the company shows only historic charges dating back from 1993.

(6) **Vehicle Standards:**

COF Pass rate:		94%	84.7%
CoF Faults Per Failed Vehicle (FPFV):		1.26	3.2
COF Average faults on all inspections:		0.07	3.0
Total number of COF inspections:		340	
Total number of COF faults:		24	
Total Passes:		321	
Total Fails:		19	
RID pass rate:		56%	82.9%
RID Faults Per Failed Vehicle (FPFV):		1.4	1.3
RID Average faults on all inspections:		0.6	0.2
Total number of RID inspections:		103	
Total Number of Vehicles Inspected:		184	
Total number of RID faults:		111	
TOTAL NUMBER OF PINK STICKER FAULTS:		15% / 27	
TOTAL NUMBER OF GREEN STICKER FAULTS:		8% / 15	
TOTAL NUMBER OF G2 FAULTS:		21% / 39	
TOTAL NUMBER OF VEHICLE PASSES:		56% / 103	
Total number of vehicles in fleet:		97	
Average age of trucks:		6.57 Years	
Average age of trailers:		6.75 Years	
Average age of fleet:		6.66Years	

Released under the Official Information Act 1982

Main COF Faults:	% of all faults and number of faults
BRAKES	59% / 13
SUSPENSION	14% / 3
EXTERIOR	9% / 2
CHASSIS	9% / 2
TOWING	5% / 1
AIR SYSTEM	5% / 1
Main Roadside faults:	% of all faults and number of faults
LIGHTING	47% / 52
BRAKES	22% / 24
WHEELS AND TYRES	9% / 10
SUSPENSION	6% / 7
MOTIVE	5% / 6
EXTERIOR	7% / 8
TOWING	2% / 2
VEHICLE	2% / 2

Hyperion "First Failed COF" analysis was completed for a period of two years between 28/02/2017 and 27/02/2019 which included 97 heavy goods vehicles operated by Pacific Haulage Limited. A roadside inspection report was also completed for the same period which includes 184 vehicles in 103 inspections. The summary of the results is appended below.

**Pre-visit, file review (COF and RID reports) comments:**

Noting the percentage difference between the COF pass rate and the RID pass rate it appears that the company carried out Vehicle Condition Assessments prior to presenting vehicles for a COF. Alternatively, drivers are not undertaking walkaround checks and not reporting faults which can reduce the operator's ability to maintain the vehicles to COF standards.

On eighteen occasions, sixteen vehicles were presented for COF inspections with expired COF's, where they were expired by either 354 days, 109 days, 74 days, 59 days, 54 days, 20 days, 17 days, 11 days, 8 days, 6days, 5 days, 4 days, 3 days and 1 day. Any vehicle under 5 days may not have been used and may have been getting repairs to prepare for the COF inspection. Others at the high end, may have been parked up or could have had crash damage or other major repairs required. At the time of a meeting this topic will need to be covered to insure vehicle aren't being used with expired COF's.

- Although the above summary confirms the fleet COF pass rate is above the current national average, the roadside inspection pass rate is 56% showing an issue between COF's and service inspections. Lack of monitoring or maintenance systems along with daily walkaround checks could be the main contributing factors.
- The highest number of roadside faults identified was lighting at 47%, made up of 52 faults which relates to any walkaround check system having gaps.

- The most number of faults identified at COF inspections were brakes which indicates safety issues relating to brake components. The most common fault with brakes in, brake imbalance (match), with are approximately two occasions noted for the brakes need to improve.
- The above information indicates that the operator has scope to improve systems to better monitor and maintain the vehicle fleet to "Fit and Proper" status as required by Land Transport Act 1998: (Section 30A (1) (a)).
- All other information is contained in the graphs above.

(7) **Debt to the Agency:** No outstanding debt with NZTA

(8) **Debt to Ministry of Justice:** No outstanding debt disclosed.

(9) **RUC Issues:** NO RUC offences have been identified.

(10) **Other criminal/traffic offences that require further investigation, include SOF:** None identified.

(11) **Permits:** The last two year TOH shows two offences for one overweight vehicle - a breach of a tandem axle mass limit which incurs a breach of the HPMV permit also. Another vehicle was the subject of an overdimension permit breach within this period.

(12) **Complaints:** No complaint's recorded or received.

s9(2)(ba)(i)

(14) **Recommendation:**

The operator has an issue with maintenance which is reflected by the large gap between COF and Roadside inspections. I would suggest a visit is needed to address this gap in maintenance standards, Current systems should be checked and adjusted to increase the auditing and effectiveness of walkaround checks to reduce faults like lighting and tyre faults. This will help improve the poor RID pass rate which is 56%.

s9(2)(a)

Nathan Murrell  
Commercial Transport Officer



Pacific Haulage Limited

107 Aerodrome Road

Matawhero

GISBORNE

To 

**Notice of Audit**

Section 198 Land Transport Act 1998 (PART A)

**PART A**

Pursuant to section 198 of the Land Transport Act 1998, the NZ Transport Agency (the Agency) may, in writing, require any person who holds a land transport document that authorises the provision of a service in the land transport system to undergo such inspections and audits as the Agency reasonably considers necessary in the interests of land transport safety.

The Agency may require any information that it reasonably considers to be relevant to the inspection or audit.

A person who is required by the Agency to provide information under section 198 must comply with that requirement, and there is a related offence in section 51 of the Land Transport Act 1998 for failing or refusing (without reasonable excuse) to comply with a requirement in relation to an audit or inspection.

Relevant sections of the Land Transport Act 1998 are attached at **Appendix 1** for your information.

You are hereby advised of the Agency's intention to conduct an audit of the vehicles and records in respect of the transport services provided under the Transport Service Licence (TSL) number  issued in the name Pacific Haulage Limited.

In order to facilitate the audit, **you are required to provide the following information:**

1. Copies of current employment and/or contractual agreements for the following drivers:

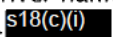

These are to be provided regardless of whether the driver is or is not currently employed by or contracted to Pacific Haulage Limited.

2. A GPS Overspeed summary report for the calendar month of February 2019 for all vehicles, showing overspeed events by "Number of Events by Vehicle" and "Number of Events by Speed Band", and showing both the driver name and vehicle identification, for all vehicles operated by Pacific Haulage Limited, TSL 

Released under the Official Information Act 1982

3. Detailed GPS Overspeed reports for the following six vehicles, showing the time, date, location and speed for all individual overspeed occurrences for the calendar month of February 2019.
  - PHL02
  - PHL13
  - PHL26
  - PHL34
  - PHL39
  - PHL40
4. All documentation and correspondence related to the identification and reporting of all overspeed related incidents for those six vehicles listed above for the calendar month of February 2019. This is to include all correspondence between the company and drivers showing where action has been taken to address overspeed incidents, and any remedial action taken where required.
5. All documentation relating to traffic offending, work time and/or logbook breaches for all drivers for the 3 month period from 10<sup>th</sup> December 2019 to 10<sup>th</sup> March 2019 inclusive.
6. All documentation relating to drug testing of all drivers for the 12 month period ending Sunday 10<sup>th</sup> of March 2019, including but not limited to requests for testing, results for testing and employment action taken as a result of test results. This is to include all testing for pre-employment purposes whether the subject was or was not subsequently employed by Pacific Haulage Limited.
7. All or any documentation, whether written or electronically recorded by drivers for the purpose of daily vehicle pre-deployment checks for all vehicles operated by Pacific Haulage Limited, TSL s18(c)(i) for a one month period from Monday 11<sup>th</sup> February 2019 to Sunday 10<sup>th</sup> of March 2019 inclusive.
8. All vehicle maintenance records for vehicles operated by Pacific Haulage Limited, TSL s18(c)(i) including but not limited to fault sheets, job sheets or cards, service and maintenance records, check sheets and reports from Monday 11<sup>th</sup> February 2019 to Sunday 10<sup>th</sup> of March 2019 inclusive. Invoices provided by s9(2)(b)(ii) previously submitted are to be excluded.

All items must be sent to the Agency either in person or by courier to NZTA, Level 2, 50 Victoria Street, Wellington, Attention Nathan Murrell or electronically via email to nathan.murrell@nzta.govt.nz by 5pm on Monday the 1<sup>st</sup> of July 2019.

Please be advised that failing or refusing to comply with any requirements of sections 30ZD or 30ZH is an offence under sections 79N and 79Q of the Land Transport Act 1998.

Yours Sincerely

s9(2)(a)

Nathan Murrell

Commercial Transport Officer

## Appendix 1

### LAND TRANSPORT ACT 1998

#### **198 Inspections and audits**

- (1) The Agency may in writing require any person who holds a land transport document that authorises the provision of a service in the land transport system to undergo such inspections and audits as the Agency reasonably considers necessary in the interests of land transport safety (including inspections and audits of vehicles operated by such persons).
- (2) The Agency may carry out such inspections and audits as the Agency reasonably considers necessary in the interests of land transport safety.
- (3) For the purposes of any inspection or audit carried out in respect of any person under this section, the Agency may in writing require that person to provide such information as the Agency reasonably considers relevant to the inspection or audit.
- (4) A person to whom a requirement is made under this section must comply with that requirement.

#### **51 Contravention of section 198(4)**

- (1) A person commits an offence if the person, without reasonable excuse, fails or refuses to comply with a requirement made under section 198 in relation to an audit or inspection.
- (2) The maximum penalty on conviction for an offence against subsection (1) is a fine not exceeding \$5,000.

#### **30A Requirements for vehicles**

- (1) A holder of a transport service licence must ensure that—
  - (a) every vehicle to be used in the service is maintained in a fit and proper condition and that the requirements of any Act, regulation, or rule made for this purpose are met;
  - (b) no vehicle is used in the service unless and until all fees payable in respect of the vehicle and the service under any Act, regulation, or bylaw have been duly paid or appropriate arrangements have been made for payment.
- (2) The holder of any transport service licence must, whenever required to do so by the Agency, present for inspection any transport service vehicle used in the service.
- (2A) The driver of a small passenger service vehicle must, whenever required to do so by the Agency, present the vehicle for inspection.
- (3) No evidence of vehicle inspection may be issued in respect of a transport service vehicle unless the person issuing the evidence of vehicle inspection has been notified of the transport service licence number under which the vehicle is being operated.
- (4) No person may use a transport service vehicle if that vehicle has suffered serious damage until the vehicle has been inspected and passed as being safe by a person authorised by the Agency, or the owner of the vehicle has been informed by such a person that the vehicle is not to be inspected.
- (5) Nothing in subsection (1), (3), or (4) applies to a vehicle used in a small passenger service.
- (6) Nothing in this section applies to—
  - (a) the facilitator of a facilitated cost-sharing arrangement; or
  - (b) a vehicle used in a facilitated cost-sharing arrangement; or
  - (c) a vehicle designed or adapted to carry 12 or fewer persons (including the driver) provided by one of the passengers being carried.

#### **30ZD Records must be kept**

- (1AA) Subsection (1) applies to—
  - (a) a person who employs a person to drive a vehicle referred to in section 30ZB; and
  - (b) a self-employed driver who drives a vehicle referred to in section 30ZB; and
  - (c) a facilitator who facilitates a driver who drives a vehicle referred to in section 30ZB to connect with passengers.

- (1) A person to whom this section applies must keep all—
  - (a) time records, records of payments to the driver, and employment or contractual records relating to the driver; and
  - (b) accommodation records and receipts for the driver that are relevant to the driver's transport service or transport service vehicle; and
  - (c) fuel records and receipts for the relevant transport service vehicles.
- (2) The person who keeps the records required under subsection (1) must—
  - (a) keep each record for 12 months from the date it is made; and
  - (b) make all relevant records referred to in subsection (1) in the possession or control of that person available for immediate inspection on demand at any reasonable time by an enforcement officer.
- (3) Every enforcement officer to whom records are made available for inspection under subsection (2)(b) is entitled to make copies of those records.

#### **79N Failure to keep or produce records or comply with conditions of exemption or approval**

Every person commits an offence who fails or refuses to comply with any of the requirements of section 30ZD or the conditions of any exemption granted or approval given under section 30ZA(1)(a) or (c), and is liable on conviction,—

- (a) in the case of a driver, to a fine not exceeding \$2,000, and the person may, for a period of 1 calendar month or such greater period as the court thinks fit, be disqualified from holding or obtaining a licence to drive any vehicle that—
  - (i) requires a class 2, 3, 4, or 5 licence (as specified in the rules); or
  - (ii) is used in the relevant transport service; or
  - (iii) is used to carry goods for hire or reward; or
- (b) in any other case, to a fine not exceeding \$100,000.

#### **30ZH Duties regarding logbooks**

- (1) A driver must—
  - (a) retain a logbook required to be maintained by that driver under section 30ZF for a period of 12 months after the date of the last entry in that logbook; and
  - (b) in the case of a driver who is an employee, or who is driving on behalf of a transport service operator, or who is facilitated to connect with passengers by a small passenger service operator, deliver a copy of each completed logbook record to the driver's employer or transport service operator within 14 days after completing that record, and the employer or transport service operator must retain the copy of each logbook record for a period of 12 months from the date of the record.
- (1A) Despite anything in subsection (1), if the logbook only contains entries for a light RUC vehicle (as defined in section 5(1) of the Road User Charges Act 2012), the driver must retain the logbook only for a period of 12 months.
- (2) A driver must—
  - (a) carry a logbook with him or her at all times when driving a vehicle to which section 30ZE applies; and
  - (b) produce, on demand by any enforcement officer and without delay, any logbook that—
    - (i) the driver is required to maintain; and
    - (ii) relates to—
      - (A) the day of the driver's last rest time of at least 24 hours; and
      - (B) all the days since that rest time.
- (3) If the form of the logbook required to be maintained under section 30ZF includes an identical copy made simultaneously with the original of that logbook, and the logbook has been produced to an enforcement officer, that enforcement officer is entitled, on demand,—
  - (a) to remove that identical copy; or
  - (b) if that identical copy has previously been removed or is illegible, to make a copy of that logbook.
- (4) A person who is required to retain a logbook or a copy of a logbook under subsection (1) must make it and all relevant time records, records of payments to the driver, and employment or contractual records relating to the driver available for immediate inspection on demand by an

enforcement officer at any reasonable time during the period for which it is required to be retained.

- (5) A person to whom a logbook or a copy of a logbook or records are required to be made available for inspection under subsection (4) is entitled to make a copy of that logbook or that copy or those records.

**79Q Failure to discharge duties regarding logbooks**

Every person who fails or refuses to comply with any requirement of or demand made under section 30ZH commits an offence and is liable on conviction,—

- (a) in the case of a driver, to a fine not exceeding \$2,000, and the person may, for a period of 1 calendar month or any greater period that the court thinks fit, be disqualified from holding or obtaining a licence to drive any vehicle that—
- (i) requires a class 2, 3, 4, or 5 licence (as specified in the rules); or
  - (ii) is used in the relevant transport service; or
  - (iii) is—
    - (A) a heavy motor vehicle; and
    - (B) used to carry goods for hire or reward:
- (b) in any other case, to a fine not exceeding \$25,000.

**113A Power to inspect records**

- (1) For the purpose of ascertaining whether this Act has been or is being complied with by any person to whom this Act applies, any enforcement officer in uniform or in possession of a warrant or other evidence of his or her authority as an enforcement officer may require that person to produce without delay for inspection all relevant books or records in that person's possession or over which that person has control, including (but not limited to) records kept under section 65 of the Road User Charges Act 2012, logbooks, records associated with logbooks, financial records relating to expenditure on fuel, invoices, vehicle maintenance records, depreciation records for vehicles, time and wage records, and waybills.
- (2) The enforcement officer may take extracts from or make copies of any books or records so produced.

Released under the Official Information Act 1982

# Entity Linking Process

Date Printed: 10/02/11

Licence Number	Company Name	Ltsa Id	s9(2)(a)	TSL Number	TSL Status
s18(c)(i)	PACIFIC HAULAGE LIMITED			s18(c)	Current
	PACIFIC HAULAGE LIMITED				
	PACIFIC HAULAGE LIMITED				
	PACIFIC HAULAGE LIMITED				
	PACIFIC HAULAGE LIMITED				
	PACIFIC HAULAGE LTD				

Companies still exists

Check company is the same entity (companies register)

Validate TSL number

Establish and validate master licence number (usually starts PZ e.g. PZ123456)

Check if current DriverCheck/TORO customer (confirm with DriverCheck administrator)

Instruction for Regional Enquiries:

Master license number:

---

Master identity number:

---

License/s number to link to master:

---

Identity/ies to link to master:

---

email completed form to: [company.linking@nzta.govt.nz](mailto:company.linking@nzta.govt.nz)

Any queries contact a member of the Hyperion User Group

Released under the Official Information Act 1982



NZ TRANSPORT AGENCY  
WAKA KOTAHI

## Vehicle Specialist Report Operator Vehicle Maintenance Records Assessment for PACIFIC HAULAGE LIMITED

TSL number:	s18(c)(i)
Operator's name:	PACIFIC HAULAGE LIMITED
Operator type:	GOODS SERVICE
Industry/vehicle type:	LOG HAULAGE.
Vehicle Specialist:	NEIL McALPINE

Vehicle Data	Current Results Date: 28/02/2019 COF and 1/03/2019 RID
COF Pass rate:	94%
COF Faults Per Failed Vehicle (FPFV):	1.26
COF Average faults on all inspections:	0.07
Total number of COF inspections:	340
Total number of COF passes:	321
Total number of COF fails:	19
Total number of COF faults:	24
Total number of vehicles inspected:	97
Average age of Fleet	6.66 years
RID pass rate:	56%
Total of RID passes	103
Total of RID fails	81
Total number of RID faults:	111
RID Faults Per Failed Vehicle (FPFV):	1.37037
RID Average faults on all inspections:	0.60326
Total number of RID inspections:	103
Total number of vehicles inspected: (some more than once)	184

Released under the Official Information Act 1982

	The below COF percentages are out of 100% for each category
<b>Main COF Faults as percentage of failed inspections:</b>	<b>% of all faults and number of faults per-category</b>
Air Systems	5% / 1
Brakes	68% / 13
Chassis	11% / 2
Exterior	11% / 2
Lighting	11% / 2
Suspension	16% / 3
Towing	5% / 1
<b>Main Roadside faults as percentage of failed inspections:</b>	<b>% of all faults and number of faults</b>
Air Systems	9% / 10
Brakes	22% / 24
Exterior	7% / 8
Lighting	47% / 52
Motive	6% / 6
Suspension	6% / 7
Towing	2% / 2
Vehicle	2% / 2
	100% / 111

The COF and Roadside Inspection Databases records show that this operator's COF pass rate of (95%) is above the national average pass rate of 84% and the Roadside pass rate of (56%) is lower than the national RID pass rate of 84%.

The below average roadside pass rate indicates a problem either the drivers not doing walkaround inspection on these failed vehicles or the workshop isn't addressing faults identified to then, it's most likely a driver issue when looking at the number of lighting faults at 52.

Maintenance Document Review:

A review of the service records supplied, were checked to ensure that the servicing, maintenance and repairs undertaken in-house is being done in a regular proactive manner and in-line with the requirements of the Land Transport Act 1998 section 30A (1), and Land Transport Rule: Vehicle Repair 1998.

A review of the records shows that while the invoices have brief notes about repairs or a safety check being done, there was one (1) workshop document to show a service but nothing to confirm what repairs were done, this would show sign off on faults found. The records should include service or check sheets, or any forms used by the workshop staff to say what servicing is done and what items are included in the service, or what has been repaired.

When looking through the first combination (Truck and Trailer) PHL01 – 2760L, there are a lot of invoices dating from the 31<sup>st</sup> December 2018 to 11<sup>th</sup> March 2019. These are a tax invoices with very brief notes e.g. carry out safety check, grease vehicle. There is one invoice for each vehicle, an example is Tax Invoice 226115-1 for PHL01, this invoice notes the service date, speedo and hubometer readings, one and a half hours labour with carry out safety check, grease vehicle. The trailer invoice 226130-1



has service date, no hubometer reading, carry out service check and replace bolster chain, one and a half hours labour, and not much else. Neither vehicle has a check sheet to indicate what items were checked as part of any service. While some documents provided have the hubometer readings noted, it isn't the norm from what can be seen. Two more documents were supplied and titled Vehicle Fault Sheet, these appear to be filled out by the driver to address faults they identify. I believe there would be more than two (2) of these documents for a 3-month period.

The documents provided are not the documents that should have been given to allow the audit to be undertaken, the documents that need to be retained and supplied on request are the walkaround check sheets done by the driver and any service sheets used either by the in-house mechanics or outside service providers. These are the documents that show what has accurately happen during a service or repair in the workshop not the tax invoice. As a service provider, the workshop undertaking repairs on vehicles should be using a service or job sheet which the mechanics fill out and this should be scanned or photocopied and supplied to the customer with the tax invoice for their records.

After going through the documents provided it's become clear that the data on the invoices don't include speedo or hubo readings all the time and even when they are entered there are typo's where the hubometer readings change, some by 300,000kms. This makes it very difficult to ensure that servicing is be done within a set distance. The dates appear mostly weekly with a grease and a safety check once a month. Due to the inaccurate tax invoice information, it's difficult to sure what servicing is carried out and what is covered during the service.

Due to the information supplied it's not worth the time to go through each tax invoice for each truck and trailer to try to work out and correct typos to build a photo of what is actually done and at what distance. The service dates are included on the tax invoices which is helpful to see time frames for servicing, but with inconsistent speedo and hubometer readings, as well as not all the information appearing to be on the tax invoices, makes it very difficult to follow and check.

With a roadside pass rate of 56% and 111 faults being found on 81 vehicles, this is a disappointing result for an operator that has a large fleet and operates their own workshop, there is room to improve system that are currently in place and this would include working with the drivers and workshop staff to improve the roadside inspection outcomes.

The Land Transport Act 1998 section 30A (1) requires vehicles to be maintained to act, regulations and rule (see below).

### **30A Requirements for vehicles**

(1) A holder of a transport service licence must ensure that—  
(a) every vehicle to be used in the service is maintained in a fit and proper condition and that the requirements of any Act, regulation, or rule made for this purpose, are met:

Land Transport Rule: Vehicle Repair 1998, requires that vehicles are maintained

2.1(1) A repair to a vehicle, its structure, systems, components or equipment, must restore the damaged or worn vehicle, structure, system, component or equipment so that they are within safe tolerance of the state of the vehicle, structure, system, component or equipment when manufactured.

2.1(2) If the vehicle has been certified as a modified vehicle, the repair must restore the vehicle, structure, system, component or equipment so that the vehicle is within safe tolerance of its state when certified as a modified vehicle.

Anything less than 100% pass rates for both COF and Roadside inspections shows that Pacific Haulage Limited aren't complying with the above acts and rules.

In the first instance, I recommend monitoring the vehicles via COF and Roadside inspections three monthly over the next twelve months, this is to check the operator's compliance levels. The vehicles that are currently failing roadside inspections should be put on 3-month COF inspections to assist with ensuring that they are compliant at all times.

NZTA can assist Pacific Haulage Limited by supplying a roadside inspection report to assist the workshop and fleet manager address the current low roadside pass rate. This report will also assist with addressing the drivers that may not carry out a walkaround check and items that the workshop may be not picking up as part of their current service programme.

If things don't improve a fleet audit should be done to identify what the compliance level of the fleet is. The results of any audit (if carried out) can be assessed at that time to gauge the operation compliance level.

s9(2)(a)

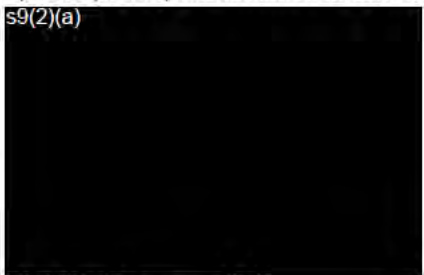

Neil McAlpine  
Vehicle Specialist  
Wellington

17<sup>th</sup> May 2019

Released under the Official Information Act 1982

# Permit or Authority for high-productivity motor vehicle to exceed length limits

ISSUED UNDER section 5 of Land Transport Rule: Vehicle Dimensions and Mass 2016 (the Rule)

Note: this document is NOT a permit to exceed mass limits - it refers to length limit dimensions only.

1. IF NOT HIGHER MASS - In the event that the vehicle is not operating on an HPMV higher mass permit then this document is a complete high productivity motor vehicle permit, issued under 5.9(1)(b) of the Rule.
2. IF HIGHER MASS - In the event that the vehicle is operating on an HPMV higher mass permit then this document enables the issue of an HPMV permit under 5.9(1)(b) of the Rule.

## Authorisation

The vehicle combination specified on this permit has been assessed and authorised by the NZ Transport Agency under clauses 5.9(5) and 5.9(6) of the Rule, as providing safety performance equivalent to that of a standard motor vehicle. This permit sets out the operating requirements for the approved combination.

Operator name: PACIFIC HAULAGE LIMITED

TSL number s18(c)(1)

is hereby authorised to use the vehicle combination specified on this permit:

Truck = PHL44                      Trailer/s = 41T22

for high productivity motor vehicle trips, with EITHER any route restrictions described below OR General access to New Zealand roads unless otherwise restricted (e.g. route prohibited for use by heavy traffic)

Maximum permitted gross mass: *general access limits* as set by Part 2 of Schedule 3 in the Rule; a separate permit is required for higher mass limits.

Date of issue: 21/08/2019

Date of expiry: N/A

## Vehicle configuration

The dimensions of the vehicle including the load must not exceed any of the length limits shown below. Refer to Schedule 2 in the Rule for dimensions not shown here.

**HPMV 23m TRUCK AND FULL TRAILER (LOGS)** (available from [Mesa 10/19](#))

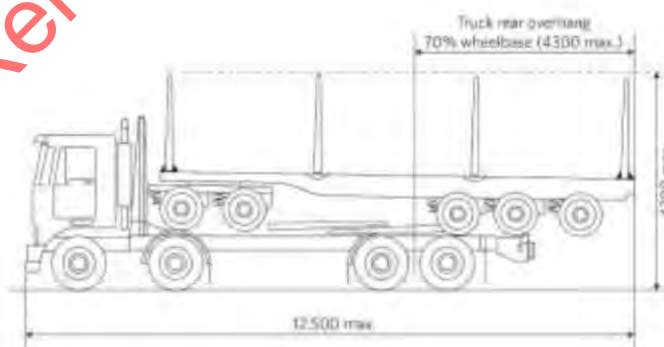
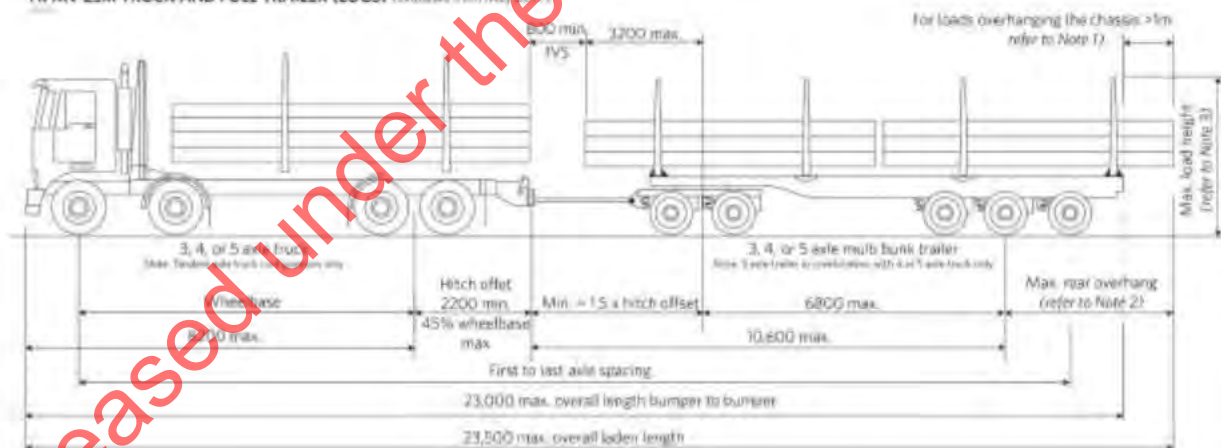

- Note 1** For loads overhanging the chassis by more than 1.0m warning flags or hazard panels are required. The length of the vehicle combination including load must not exceed 23.5m.
- Note 2** Maximum trailer rear overhang from rear axle = 3,400m or 50% of trailer wheelbase - subject to compliance with Note 1.
- Note 3** Maximum load height - Certified SRT of 0.25g at nominated maximum load height for trailers equipped with active roll stability control (RSC).
- Note 4** If a 5 axle truck tags up to 6.1m must be double burdened on the trailer, or gross combined weight restricted to 45,000kg.
- Note 5** Truck may be 5 axle if tandem drive. Trailer may be 5 axle.
- Note 6** Trailer may be 3 axle for operations up to 45,000kg.

These vehicles are treated as standard motor vehicles for all other requirements and enforcement actions except for the length dimensions that are identified on this permit.

**Route restrictions**

(if any)

**Critical conditions**

The vehicle must not –

1. exceed the maximum permitted gross weight stated on this permit
2. exceed design limits, such as GVM
3. breach a travel restriction or requirement for a specified bridge or culvert

**Additional conditions**

1. Trailer Roll Stability Control (RSC): The trailer(s) if first registered on or after 1 May 2010 must have roll stability control fitted and active; that is an Electronic Brake System (EBS) with the roll stability control function turned on. Alternatively if the trailer(s) were first registered before 1 May 2010 or are log trailers carting round wood first registered before 1 April 2016 and do not have EBS and RSC – these must instead operate with a minimum Static Roll Threshold (SRT) of 0.4 g, provided the SRT document of compliance is kept with this permit and produced to enforcement officers.

**Requirement to observe permit conditions**

A breach of weight limits specified on this form, or any permit condition, is an offence as provided in the *Land Transport (Offences and Penalties) Regulations 1999*.

**Permit is invalid if**

- a) the vehicle is off-route, unless directed to do so by NZ Police or the road controlling authority
- b) the permit is altered without authority
- c) the vehicles or persons operating the vehicles are not those described on the permit.

**Revocation**

This permit can be revoked under clause 5.7 of the Rule

*Authorised Issuing Officer*

s9(2)(a)



(Signature)

.....  
Angela Short

(Name)

Senior Customer Access Representative  
for NZ Transport Agency  
21 August 2019

(Designation)  
(Controlling Authority)  
(Permit Dated)

**Notes**

1. This permit must be carried in the towing vehicle when operating as an HPMV, and must be produced on demand to any enforcement officer, or an authorised agent of the NZ Transport Agency or a road controlling authority
2. This permit does not exempt the holder from complying with all other acts, regulations and other laws (including those relating to certificate of loading and road user charges).

Further information about permits to exceed mass limits can be found on the NZ Transport Agency website, <http://www.nzta.govt.nz/>.

**Fees payable:**

Permit issuing fee ( Land Transport (Certification and Other Fees) Amendment Regulations 2016)	\$54.55
GST	\$8.18
<b>Total</b>	<b>\$62.73</b>

# 50MAX: Permit for high-productivity motor vehicle (HPMV) to exceed mass limits

UNDER Section 5 of Land Transport Rule: Vehicle Dimensions and Mass 2016 (the Rule)

Permit number 50MAX-HPMV-19-24869

TSL number: s18(c)(i) TSL company name: PACIFIC HAULAGE LIMITED  
 is hereby authorised to use the vehicle combination(s):

Registration Truck: PHL44 Trailer 1: 41T22 Trailer 2:  
 numbers:

for high productivity motor vehicle trips to carry divisible loads with general access to the roads, subject to the region of travel restrictions specified in *Conditions for routes and structures* section of this permit, and subject to the conditions and maximum mass limits in this permit. The above vehicle combination(s) has a minimum of nine (9) axles in the axle configuration displayed in the diagram below.

**50MAX 23m TRUCK AND FULL TRAILER (LOGS)** (available from May 2019)

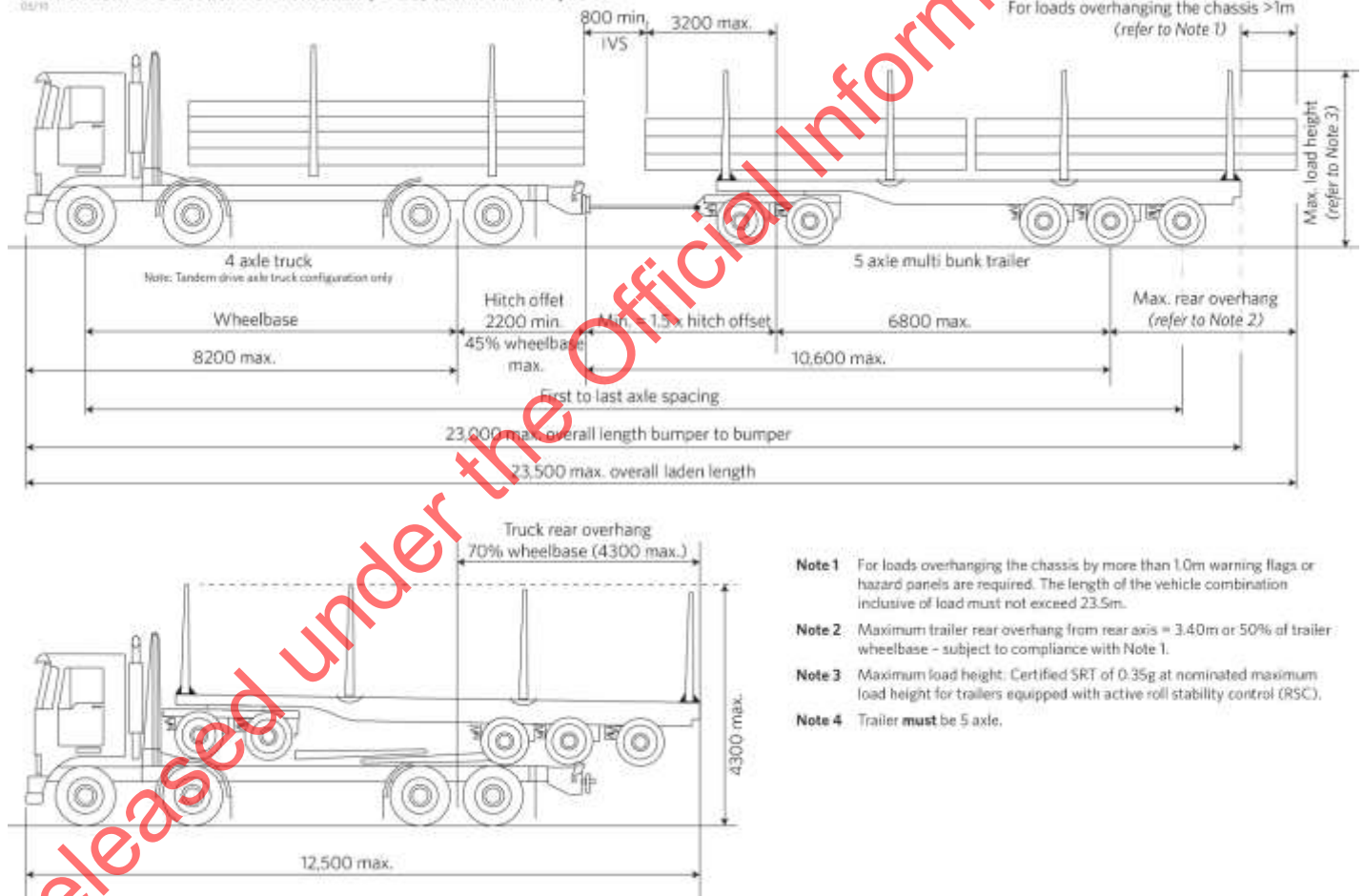

## Maximum gross mass

The maximum permitted gross mass is 50,000 kilograms.

## Length first to last axle

Length first to last axle of 20.090 metres and a maximum overall length of 23.000 metres.

## Validity

This permit is valid for high productivity motor vehicle trips from 21/08/2019 to 21/08/2021.

## Requirement to observe permit conditions

This permit is invalid if:

1. The vehicle is off-route, unless directed to do so by NZ Police or the road controlling authority
2. The permit is altered without authority
3. The vehicles or persons operating the vehicles are not those described on the permit.

## Critical conditions

The vehicle combination(s) must not:

4. Exceed the maximum permitted gross weight of 50,000 kilograms.
5. Exceed design limits, such as GVM.
6. Breach a travel restriction or requirement for a specific bridge or culvert specified in 11-14 below.

## Additional conditions

7. Trailer Roll Stability Control (RSC): The trailer(s) if first registered on or after 1 May 2010 must have roll stability control fitted and active; that is an Electronic Brake System (EBS) with the roll stability control function turned on. Alternatively if the trailer(s) were first registered before 1 May 2010 or are log trailers carrying round wood first registered before 1 April 2016 and do not have EBS and RSC - these must instead operate with a minimum Static Roll Threshold (SRT) of 0.4 g, provided SRT compliance documentation is kept with this permit and produced to enforcement officers.
8. This permit must be carried in the vehicle and must be surrendered for inspection on the demand of any enforcement officer, or an authorised agent of NZ Transport Agency or a road controlling authority.
9. *Separate plant*: the towing of separate items of plant or equipment not specifically listed by registration number on this permit is not permitted.

## Revocation

10. This permit can be revoked under clause 5.7 of the Rule.
11. A breach in any of the conditions found in a permit may result in a revocation of the permit.

## Conditions routes and structures

12. Travel is permitted as defined by the 50MAX book of maps and conditions 12, 13 and 14 and 15 below.
13. The vehicle combination(s) operating under this permit is permitted to travel on all roads in the Island(s) specified in condition 20 of this permit subject to the restrictions specified in the current version of the 50MAX book of maps.
14. The vehicle combination(s) operating under this permit must not cross any restricted structures listed in the current version of the 50MAX book of maps and must also comply with any other restrictions imposed by a road controlling authority on roads or structures under its control (for example, individual bridge postings).
15. This permit does not apply to travel on any noted as restricted or limited the current version of the 50MAX book of maps.

## General terms

16. The vehicle shall not be operated on a road or bridge under this permit when in the opinion of the Road Controlling Authority, it is necessary for protection of infrastructure, or safety of road users, to prohibit the vehicle from travel on that road or bridge.

---

Authorised Issuing Officer

s9(2)(a)

Angela Short  
Senior Customer Access Representative on behalf of the NZ Transport Agency  
Date of Issue: 21/08/2019

## Notes

IMPORTANT: 50MAX permits allow for considerable additional access to the network for increased mass road transport. The resulting gains in economic efficiency must be achieved with due consideration for the safety of road users. It is therefore important that operators respect this permit and take on a level of self monitoring and compliance which will ensure the confidence of the travelling public in the road transport industry. The Transport Agency is aware that a number of operators are investing in speed limiting, GPS monitoring, load cells, electronic stability control, ERUC and other safety measures. The Transport Agency recommends that all road transport operators consider the use of such available technology where it is applicable.

17. *Weighing*: enforcement officers are authorised to divert vehicles up to five kilometres from the approved route for the purpose of weighing, provided the diversion does not cross under-strength bridges.
18. *Identification sign*: the vehicle shall display a high-productivity motor vehicle sign in accordance with section 5.10 of the Rule when operating as a high-productivity motor vehicle.
19. *Overlength*: an overlength permit is required in addition to this authorisation if the vehicle exceeds the dimension limits in section 4 of the VDAM Rule. Further information about permits to exceed length limits can be found on the NZ Transport Agency website [www.nzta.govt.nz/](http://www.nzta.govt.nz/).
20. *Regional travel and restricted structures*:
  - a. The operator must ensure that they (and the driver of the vehicle) are using and comply with the current version of the *50MAX book of maps* published by the NZ Transport Agency at [www.nzta.govt.nz/commercial-driving/permits/high-productivity/50max/50max-information-for-operators-and-manufacturers/](http://www.nzta.govt.nz/commercial-driving/permits/high-productivity/50max/50max-information-for-operators-and-manufacturers/).
  - b. The current version of the *50MAX book of maps* is "The 50MAX Book of Maps version that applies at the time the vehicle is operating on the road, as described below. The current version can be found here <https://www.nzta.govt.nz/commercial-driving/high-productivity/50max/50max-information-for-operators-and-manufacturers/map-of-50max-routes/>
  - c. If the NZ Transport Agency issues a new version of the *50MAX book of maps*, it will publish the new version on the webpage specified above at least 5 business days before the first day of each calendar month and the new version shall take effect on the first day of each calendar month. If no new version is published prior to the first of the month, the latest published version remains in force. Business day - means a day other than a Saturday, a Sunday, or a public holiday (as defined in the Holidays Act 2003).

Each version of the *50MAX book of maps* applies during the period beginning on the first day of the month of the year specified in the version name and ending on the last day of that month, unless no version for the following month is published by the Transport Agency in which case the latest published version remains in force.
  - d. For travel on the road network of a restricted road controlling authority, the vehicle must hold a HPMV permit issued by that road controlling authority. The vehicle combination is subject to all of the terms and conditions of the HPMV permit issued by the road controlling authority when operating on the roads under its control.
21. This permit does not exempt the holder from complying with all other acts, regulations and other laws (including those relating to certificate of loading and road user charges). Breaches of the conditions of the permit may also constitute offences in the terms of the Land Transport Act 1998.

**From:** [Apply 50 MAX](#)  
**To:** s9(2)(a)  
**Subject:** RE: 50MAX application from Pacific Haulage Ltd - PHL44 4T122 19-1530  
**Date:** Wednesday, 21 August 2019 4:01:00 PM  
**Attachments:** [~WRD311.jpg](#)  
[50MAX application from Pacific Haulage Ltd - PHL44 4T122 19-1530.msg](#)  
[1 Heavy RUC info sheet 0217.pdf](#)  
[50MAX-HPMV-19-24869.pdf](#)  
[OL-HPMV-19-1530.pdf](#)  
[image001.jpg](#)  
[image002.png](#)  
[image003.png](#)

---

Congratulations your application for a 50MAX Permit has been approved. We've attached your Permit for your reference.

#### **What do you need to do next?**

Follow the instructions in the Heavy Info Sheet (attached) to ensure the correct Road User Charges (RUC) licence has been purchased, and therefore enable you to operate legally on the road.

**Please note that from 1 June 2017 we will now be issuing one network permit which will cover you for the entire 50MAX network.**

<http://www.nzta.govt.nz/about-us/news-and-media/keeping-connected/50max-carrying-more-nz-freight/>

Below are the links to Operator Safety Checks and the link to your Book of Maps.

<https://www.nzta.govt.nz/commercial-driving/high-productivity/hpmv-operator-safety-checks/>

**Please take the time to check the permit for accuracy and to read all of the supporting documentation and notes below.**

Remember: If the local road controlling authority (RCA) has not delegated authority to the Transport Agency (refer to the Restricted RCA tables in the book of maps) to issue 50MAX permits, then you will need to apply for an HPMV route permit for the access you need directly from that RCA.

About your Book of Maps:

1. You can access and download your Book of Maps online at <http://www.nzta.govt.nz/commercial-driving/high-productivity/50max/50max-information-for-operators-and-manufacturers/>
2. The Book of Maps will change as local authority networks are opened to 50MAX and restricted structures are upgraded and can be removed from the restricted list. Changes may also include structures being added to the restricted list from time to time.
3. Updates to the Book of Maps will occur on a monthly basis. You can access and download your updated Book of Maps online at <http://www.nzta.govt.nz/commercial-driving/high-productivity/50max/50max-information-for-operators-and-manufacturers/>
4. Where an unrestricted road network or structure changes to restricted, the 50MAX



website will be updated at

<http://www.nzta.govt.nz/commercial-driving/high-productivity/50max/50max-information-for-operators-and-manufacturers/>

5. It is your responsibility to ensure you operate using the current Book of Maps at all times. Failure to do so is considered a breach of the Permit Terms and Conditions and will result in penalties.

Useful Tips for Using Your 50MAX Permit:

- It might be a good idea to laminate the pages (2-sided in one) of your Permit so that it is more durable under weather conditions and coffees
- Pop a printed copy of the Book of Maps into a Clearlite folder and carry it in the cab of your vehicle for easy reference
- Soon, you will be able to access online interactive 50MAX maps via a web browser, which will enable you to drill down to a low level when planning your journey.
- If you have a mobile device (i.e. tablet or Smartphone) you could download the current Book of Maps and the permit document(s) as a PDF file to this device.

From 1 February 2017, the rules governing heavy vehicle size, weight and operation limits are changing. Please refer to the link below for further information.

<http://www.nzta.govt.nz/commercial-driving/vdam-what-you-need-to-know>

If you have any queries about your permit please contact us on [info50MAX@nzta.govt.nz](mailto:info50MAX@nzta.govt.nz) or phone 0800 699 000. Please do not reply to this email as your queries cannot be processed via this channel, thank you.

Regards,

Alex Scott / Senior Customer Access Representative  
Permitting Assessments

PH 0800 683 774

E [alexander.scott@nzta.govt.nz](mailto:alexander.scott@nzta.govt.nz) / w [nzta.govt.nz](http://nzta.govt.nz)

Palmerston North Office  
Private Bag 11777, Palmerston North 4442, New Zealand



---

**From:** apply50max@noreply.nzta.govt.nz <apply50max@noreply.nzta.govt.nz>

**Sent:** Thursday, 15 August 2019 2:07 PM

**To:** Apply 50 MAX <apply50MAX@nzta.govt.nz>

**Subject:** 50MAX application from Pacific Haulage Ltd - PHL44 4T122 19-1530

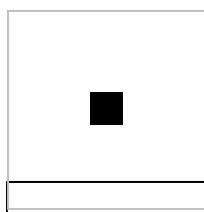

## A new 50MAX application has been received from the online form.

**TSL number:** s18(c)(1)  
**TSL company name:** Pacific Haulage Ltd  
**Email address:** s9(2)(a)  
**Contact name:** s9(2)(a)  
**Billing address:** 107 Aerodrome Road, Matawhero  
**Town/City:** Gisborne  
**Contact phone number:** s 9(2)(a)  
**Alternate phone number:**  
**Purchase order number/reference:** PHL44 & 41T22

**Prime mover registration number:** PHL44  
**Vehicle combination 1, trailer 1 reg:** 41T22 I do not have an HPMV permit to exceed length limits for this combination.  
**Vehicle combination 1, trailer 2 reg:**

**Overall length:** 23000 metres  
**First-to-last axle distance:** 20090 metres  
**Maximum Gross mass:** 50 tonnes  
**Load Type:** Logs  
**Journey Origin:** Gisborne  
**Journey Destination:** North Island

### Notes:

1. The NZ Transport Agency will invoice your NZTA account number the current fee for each permit issued from this application.  
The current fee is \$54.55 (excl. GST) per Permit issued. ((As specified in Schedule 4A of the Heavy Motor Vehicle Regulations 1974).
2. The above vehicle combination(s) are 50MAX Ready Pro Forma. You need to complete the relevant Pro Forma diagram for the vehicle combination(s) you are applying for and attached it to this application form. (You need only complete and submit one 50MAX Ready Pro Forma diagram with your application, as all trailers must be identical units. You can find the 50MAX Ready Pro Forma diagram at HPMV 50MAX Pro forma vehicle design).
3. Each of the above vehicle combination(s) requires a 50MAX Vehicle Combination Attribute Check Sheet that has been certified by a NZ Transport Agency appointed Certifier. Please attach a copy of these to this application form.
4. To operate this vehicle combination legally, you must have a current, valid High Productivity Motor Vehicle Permit to Exceed Length Limits for the vehicle combination(s).
5. You must load the vehicle combination, at all times, according to the general mass, Class One mass limits on individual axles, axle sets and combinations of axles as prescribed by the Vehicle Dimension and Mass Rule Schedule 2, Part A, Tables 1 to 5 and Table 6 extended for 50MAX. The Tables will be provided in your Permit as part of the permit Terms and Conditions.
6. Compliance with 5 above may mean, for some loads, you will be unable to load to the maximum gross mass you are permitted to load up to.
7. The above vehicle combination cannot operate with a gross mass exceeding 44 tonnes across any structure or roads restricted under the conditions of the permit.
8. The above vehicle combination cannot operate on any Local Authority road network restricted under the conditions of the permit.
9. If you wish to operate the vehicle combination on any Local Authority road network that is restricted under the conditions of the permit, you must apply to the Local Road Controlling Authority for a full High Productivity Motor

Vehicle Permit to Exceed Mass Limits and are legally bound to operate the vehicle combination under the terms and conditions of their permit within the boundary of their area of Authority.

10. You cannot operate the vehicle combination with a gross mass exceeding 44 tonnes in any Region other than what has been permitted.
11. This information requested is required to process an application for a 50MAX High Productivity Motor Vehicle Permit under the Land Transport Rule: Vehicle Dimensions and Mass 2002. The information that you provide as part of this application will be stored on, and form part of, the 50MAX Permit Register. The NZ Transport Agency may use the information for the purposes of monitoring and regulating operator behaviour. The Transport Agency may also disclose the information to Road Controlling Authorities for the purposes of network maintenance and operations.

The Privacy Act 1993, and the Official Information Act 1982, provides you with the right to access and correct any readily retrievable personal information held about you, or your company, respectively, by the Transport Agency.

Should you wish to exercise this right, please contact the NZ Transport Agency, Private Bag 11777, Palmerston North 4442 or email [info@nzta.govt.nz](mailto:info@nzta.govt.nz).

## Declaration and signatory

I declare that the particulars contained in this application are true and correct.

I confirm I have read and understood all the notes in this application form.

**Declared name:** s9(2)(a) [REDACTED]

-----  
This is an auto-generated email. Please do not reply, no-one will see it.

- *The NZTA Website*

The customer received a copy of this email.

Released under the Official Information Act 1982

# Permit or Authority for high-productivity motor vehicle to exceed length limits

ISSUED UNDER section 5 of Land Transport Rule: Vehicle Dimensions and Mass 2016 (the Rule)

Note: this document is NOT a permit to exceed mass limits – it refers to length limit dimensions only.

1. IF NOT HIGHER MASS - In the event that the vehicle is not operating on an HPMV higher mass permit then this document is a complete high productivity motor vehicle permit, issued under 5.9(1)(b) of the Rule.
2. IF HIGHER MASS - In the event that the vehicle is operating on an HPMV higher mass permit then this document enables the issue of an HPMV permit under 5.9(1)(b) of the Rule.

## Authorisation

The vehicle combination specified on this permit has been assessed and authorised by the NZ Transport Agency under clauses 5.9(5) and 5.9(6) of the Rule, as providing safety performance equivalent to that of a standard motor vehicle. This permit sets out the operating requirements for the approved combination.

Operator name: PACIFIC HAULAGE LIMITED

TSL number: §18C(1)

is hereby authorised to use the vehicle combination specified on this permit:

Truck = PHL45                      Trailer/s = 40Q14

for high productivity motor vehicle trips, with EITHER any route restrictions described below OR General access to New Zealand roads unless otherwise restricted (e.g. route prohibited for use by heavy traffic)

Maximum permitted gross mass: *general access limits* as set by Part 2 of Schedule 3 in the Rule; a separate permit is required for higher mass limits.

Date of issue: 07/08/2019

Date of expiry: N/A

## Vehicle configuration

The dimensions of the vehicle including the load must not exceed any of the length limits shown below. Refer to Schedule 2 in the Rule for dimensions not shown here.

**HPMV 23m TRUCK AND FULL TRAILER (LOGS)** (available from [Meca \(09\) 480 1000](#))

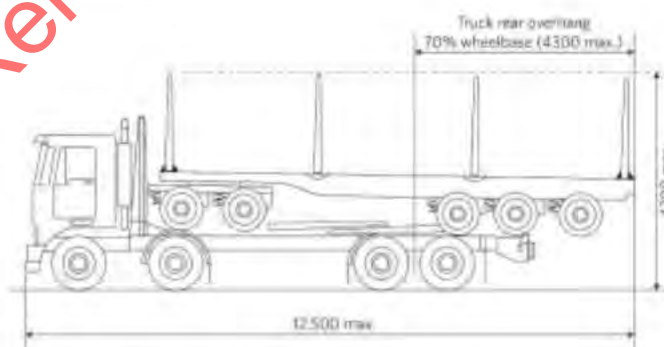
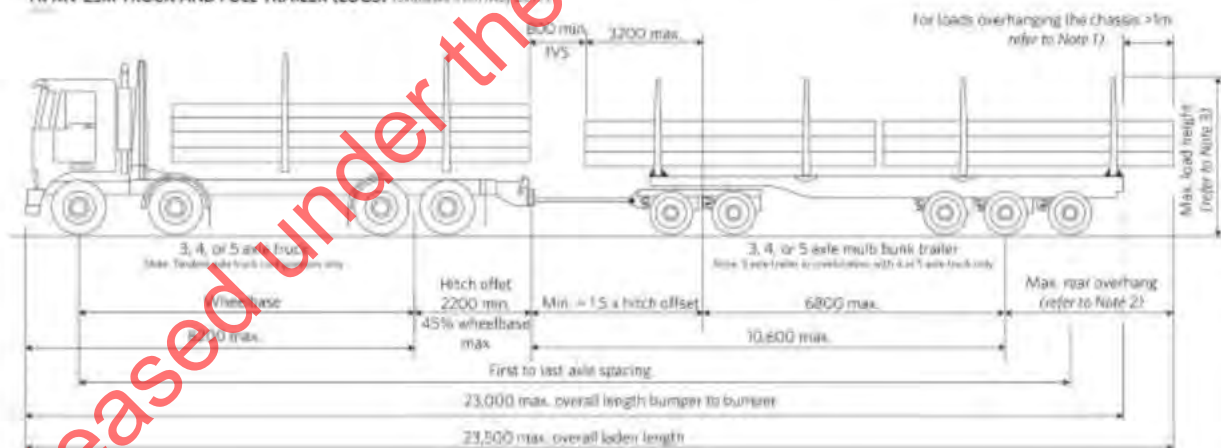

- Note 1** For loads overhanging the chassis by more than 1.0m warning flags or hazard panels are required. The length of the vehicle combination including load must not exceed 23.5m.
- Note 2** Maximum trailer rear overhang from rear axle = 3.40m or 50% of trailer wheelbase – subject to compliance with Note 1.
- Note 3** Maximum load height: Certified SRT of 0.25g at nominated maximum load height for trailers equipped with active roll stability control (RSC).
- Note 4** If a 5 axle truck tags up to 6.0m must be double burdened on the trailer, or gross combined weight restricted to 45,000kg.
- Note 5** Truck may be 5 axle if tandem drive. Trailer may be 5 axle.
- Note 6** Trailer may be 3 axle for operations up to 45,000kg.

These vehicles are treated as standard motor vehicles for all other requirements and enforcement actions except for the length dimensions that are identified on this permit.

**Route restrictions**

(if any)

**Critical conditions**

The vehicle must not –

1. exceed the maximum permitted gross weight stated on this permit
2. exceed design limits, such as GVM
3. breach a travel restriction or requirement for a specified bridge or culvert

**Additional conditions**

1. Trailer Roll Stability Control (RSC): The trailer(s) if first registered on or after 1 May 2010 must have roll stability control fitted and active; that is an Electronic Brake System (EBS) with the roll stability control function turned on. Alternatively if the trailer(s) were first registered before 1 May 2010 or are log trailers carting round wood first registered before 1 April 2016 and do not have EBS and RSC – these must instead operate with a minimum Static Roll Threshold (SRT) of 0.4 g, provided the SRT document of compliance is kept with this permit and produced to enforcement officers.

**Requirement to observe permit conditions**

A breach of weight limits specified on this form, or any permit condition, is an offence as provided in the *Land Transport (Offences and Penalties) Regulations 1999*.

**Permit is invalid if**

- a) the vehicle is off-route, unless directed to do so by NZ Police or the road controlling authority
- b) the permit is altered without authority
- c) the vehicles or persons operating the vehicles are not those described on the permit.

**Revocation**

This permit can be revoked under clause 5.7 of the Rule

*Authorised Issuing Officer*

s9(2)(a)  
[Redacted Signature]

(Signature)

.....  
Angela Short

(Name)

Senior Customer Access Representative  
for NZ Transport Agency  
07 August 2019

(Designation)  
(Controlling Authority)  
(Permit Dated)

**Notes**

1. This permit must be carried in the towing vehicle when operating as an HPMV, and must be produced on demand to any enforcement officer, or an authorised agent of the NZ Transport Agency or a road controlling authority
2. This permit does not exempt the holder from complying with all other acts, regulations and other laws (including those relating to certificate of loading and road user charges).

Further information about permits to exceed mass limits can be found on the NZ Transport Agency website, <http://www.nzta.govt.nz/>.

**Fees payable:**

Permit issuing fee ( Land Transport (Certification and Other Fees) Amendment Regulations 2016)	\$54.55
GST	\$8.18
<b>Total</b>	<b>\$62.73</b>

# 50MAX: Permit for high-productivity motor vehicle (HPMV) to exceed mass limits

UNDER Section 5 of Land Transport Rule: Vehicle Dimensions and Mass 2016 (the Rule)

Permit number 50MAX-HPMV-19-24599

TSL number: **s18(c)(i)** TSL company name: PACIFIC HAULAGE LIMITED  
is hereby authorised to use the vehicle combination(s):

Registration numbers: Truck: PHL45 Trailer 1: 40Q14 Trailer 2:

for high productivity motor vehicle trips to carry divisible loads with general access to the roads, subject to the region of travel restrictions specified in *Conditions for routes and structures* section of this permit, and subject to the conditions and maximum mass limits in this permit. The above vehicle combination(s) has a minimum of nine (9) axles in the axle configuration displayed in the diagram below.

**50MAX 23m TRUCK AND FULL TRAILER (LOGS)** (available from May 2019)

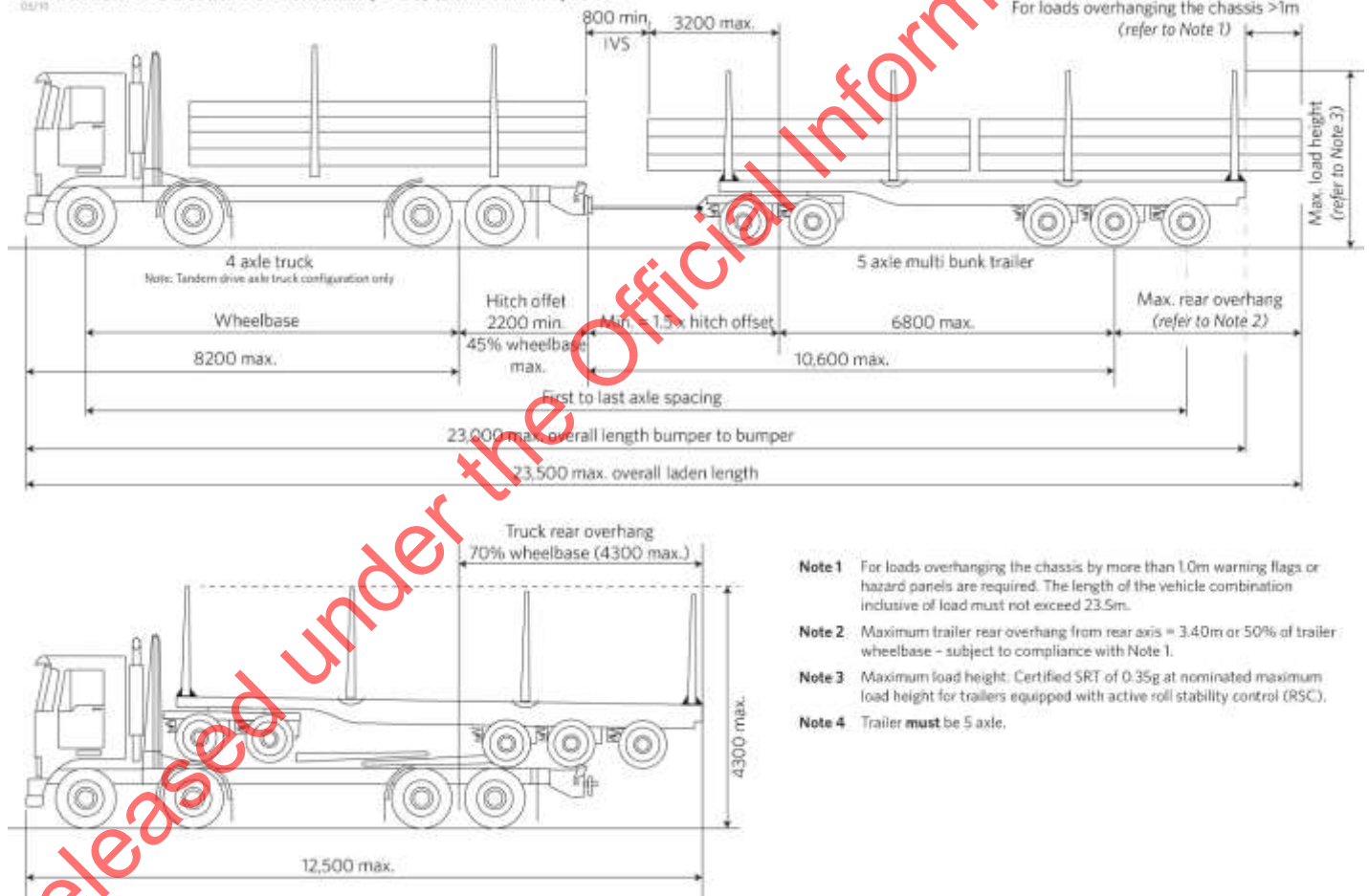

## Maximum gross mass

The maximum permitted gross mass is 50,000 kilograms.

## Length first to last axle

Length first to last axle of 20.090 metres and a maximum overall length of 23.000 metres.

## Validity

This permit is valid for high productivity motor vehicle trips from 7/08/2019 to 7/08/2021.

## Requirement to observe permit conditions

This permit is invalid if:

1. The vehicle is off-route, unless directed to do so by NZ Police or the road controlling authority
2. The permit is altered without authority
3. The vehicles or persons operating the vehicles are not those described on the permit.

## Critical conditions

The vehicle combination(s) must not:

4. Exceed the maximum permitted gross weight of 50,000 kilograms.
5. Exceed design limits, such as GVM.
6. Breach a travel restriction or requirement for a specific bridge or culvert specified in 11-14 below.

## Additional conditions

7. Trailer Roll Stability Control (RSC): The trailer(s) if first registered on or after 1 May 2010 must have roll stability control fitted and active; that is an Electronic Brake System (EBS) with the roll stability control function turned on. Alternatively if the trailer(s) were first registered before 1 May 2010 or are log trailers carrying round wood first registered before 1 April 2016 and do not have EBS and RSC - these must instead operate with a minimum Static Roll Threshold (SRT) of 0.4 g, provided SRT compliance documentation is kept with this permit and produced to enforcement officers.
8. This permit must be carried in the vehicle and must be surrendered for inspection on the demand of any enforcement officer, or an authorised agent of NZ Transport Agency or a road controlling authority.
9. *Separate plant*: the towing of separate items of plant or equipment not specifically listed by registration number on this permit is not permitted.

## Revocation

10. This permit can be revoked under clause 5.7 of the Rule.
11. A breach in any of the conditions found in a permit may result in a revocation of the permit.

## Conditions routes and structures

12. Travel is permitted as defined by the 50MAX book of maps and conditions 12, 13 and 14 and 15 below.
13. The vehicle combination(s) operating under this permit is permitted to travel on all roads in the Island(s) specified in condition 20 of this permit subject to the restrictions specified in the current version of the 50MAX book of maps.
14. The vehicle combination(s) operating under this permit must not cross any restricted structures listed in the current version of the 50MAX book of maps and must also comply with any other restrictions imposed by a road controlling authority on roads or structures under its control (for example, individual bridge postings).
15. This permit does not apply to travel on any noted as restricted or limited the current version of the 50MAX book of maps.

## General terms

16. The vehicle shall not be operated on a road or bridge under this permit when in the opinion of the Road Controlling Authority, it is necessary for protection of infrastructure, or safety of road users, to prohibit the vehicle from travel on that road or bridge.

---

Authorised Issuing Officer

s9(2)(a)

Angela Short  
Senior Customer Access Representative on behalf of the NZ Transport Agency  
Date of Issue: 7/08/2019

## Notes

IMPORTANT: 50MAX permits allow for considerable additional access to the network for increased mass road transport. The resulting gains in economic efficiency must be achieved with due consideration for the safety of road users. It is therefore important that operators respect this permit and take on a level of self monitoring and compliance which will ensure the confidence of the travelling public in the road transport industry. The Transport Agency is aware that a number of operators are investing in speed limiting, GPS monitoring, load cells, electronic stability control, ERUC and other safety measures. The Transport Agency recommends that all road transport operators consider the use of such available technology where it is applicable.

17. *Weighing*: enforcement officers are authorised to divert vehicles up to five kilometres from the approved route for the purpose of weighing, provided the diversion does not cross under-strength bridges.
18. *Identification sign*: the vehicle shall display a high-productivity motor vehicle sign in accordance with section 5.10 of the Rule when operating as a high-productivity motor vehicle.
19. *Overlength*: an overlength permit is required in addition to this authorisation if the vehicle exceeds the dimension limits in section 4 of the VDAM Rule. Further information about permits to exceed length limits can be found on the NZ Transport Agency website [www.nzta.govt.nz/](http://www.nzta.govt.nz/).
20. *Regional travel and restricted structures*:
  - a. The operator must ensure that they (and the driver of the vehicle) are using and comply with the current version of the *50MAX book of maps* published by the NZ Transport Agency at [www.nzta.govt.nz/commercial-driving/permits/high-productivity/50max/50max-information-for-operators-and-manufacturers/](http://www.nzta.govt.nz/commercial-driving/permits/high-productivity/50max/50max-information-for-operators-and-manufacturers/).
  - b. The current version of the *50MAX book of maps* is "The 50MAX Book of Maps version that applies at the time the vehicle is operating on the road, as described below. The current version can be found here <https://www.nzta.govt.nz/commercial-driving/high-productivity/50max/50max-information-for-operators-and-manufacturers/map-of-50max-routes/>
  - c. If the NZ Transport Agency issues a new version of the *50MAX book of maps*, it will publish the new version on the webpage specified above at least 5 business days before the first day of each calendar month and the new version shall take effect on the first day of each calendar month. If no new version is published prior to the first of the month, the latest published version remains in force. Business day - means a day other than a Saturday, a Sunday, or a public holiday (as defined in the Holidays Act 2003).

Each version of the *50MAX book of maps* applies during the period beginning on the first day of the month of the year specified in the version name and ending on the last day of that month, unless no version for the following month is published by the Transport Agency in which case the latest published version remains in force.
  - d. For travel on the road network of a restricted road controlling authority, the vehicle must hold a HPMV permit issued by that road controlling authority. The vehicle combination is subject to all of the terms and conditions of the HPMV permit issued by the road controlling authority when operating on the roads under its control.
21. This permit does not exempt the holder from complying with all other acts, regulations and other laws (including those relating to certificate of loading and road user charges). Breaches of the conditions of the permit may also constitute offences in the terms of the Land Transport Act 1998.



**From:** [Apply 50 MAX](#)  
**To:** s9(2)(a)  
**Subject:** RE: 50MAX application from Pacific Haulage Ltd - PHL45 40Q14 19-1412  
**Date:** Wednesday, 7 August 2019 1:59:00 PM  
**Attachments:** [~WRD095.jpg](#)  
[50MAX application from Pacific Haulage Ltd - PHL45 40Q14 19-1412.msg](#)  
[1 Heavy RUC info sheet 0217.pdf](#)  
[50MAX-HPMV-19-24599.pdf](#)  
[OL-HPMV-19-1412.pdf](#)  
[image001.jpg](#)  
[image002.png](#)  
[image003.png](#)

---

Congratulations your application for a 50MAX Permit has been approved. We've attached your Permit for your reference.

#### **What do you need to do next?**

Follow the instructions in the Heavy Info Sheet (attached) to ensure the correct Road User Charges (RUC) licence has been purchased, and therefore enable you to operate legally on the road.

**Please note that from 1 June 2017 we will now be issuing one network permit which will cover you for the entire 50MAX network.**

<http://www.nzta.govt.nz/about-us/news-and-media/keeping-connected/50max-carrying-more-nz-freight/>

Below are the links to Operator Safety Checks and the link to your Book of Maps.

<https://www.nzta.govt.nz/commercial-driving/high-productivity/hpmv-operator-safety-checks/>

**Please take the time to check the permit for accuracy and to read all of the supporting documentation and notes below.**

Remember: If the local road controlling authority (RCA) has not delegated authority to the Transport Agency (refer to the Restricted RCA tables in the book of maps) to issue 50MAX permits, then you will need to apply for an HPMV route permit for the access you need directly from that RCA.

About your Book of Maps:

1. You can access and download your Book of Maps online at <http://www.nzta.govt.nz/commercial-driving/high-productivity/50max/50max-information-for-operators-and-manufacturers/>
2. The Book of Maps will change as local authority networks are opened to 50MAX and restricted structures are upgraded and can be removed from the restricted list. Changes may also include structures being added to the restricted list from time to time.
3. Updates to the Book of Maps will occur on a monthly basis. You can access and download your updated Book of Maps online at <http://www.nzta.govt.nz/commercial-driving/high-productivity/50max/50max-information-for-operators-and-manufacturers/>
4. Where an unrestricted road network or structure changes to restricted, the 50MAX

website will be updated at

<http://www.nzta.govt.nz/commercial-driving/high-productivity/50max/50max-information-for-operators-and-manufacturers/>

5. It is your responsibility to ensure you operate using the current Book of Maps at all times. Failure to do so is considered a breach of the Permit Terms and Conditions and will result in penalties.

Useful Tips for Using Your 50MAX Permit:

- It might be a good idea to laminate the pages (2-sided in one) of your Permit so that it is more durable under weather conditions and coffees
- Pop a printed copy of the Book of Maps into a Clearlite folder and carry it in the cab of your vehicle for easy reference
- Soon, you will be able to access online interactive 50MAX maps via a web browser, which will enable you to drill down to a low level when planning your journey.
- If you have a mobile device (i.e. tablet or Smartphone) you could download the current Book of Maps and the permit document(s) as a PDF file to this device.

From 1 February 2017, the rules governing heavy vehicle size, weight and operation limits are changing. Please refer to the link below for further information.

<http://www.nzta.govt.nz/commercial-driving/vdam-what-you-need-to-know>

If you have any queries about your permit please contact us on [info50MAX@nzta.govt.nz](mailto:info50MAX@nzta.govt.nz) or phone 0800 699 000. Please do not reply to this email as your queries cannot be processed via this channel, thank you.

Regards,

Alex Scott / Senior Customer Access Representative  
Permitting Assessments

PH 0800 683 774

E [alexander.scott@nzta.govt.nz](mailto:alexander.scott@nzta.govt.nz) / w [nzta.govt.nz](http://nzta.govt.nz)

Palmerston North Office  
Private Bag 11777, Palmerston North 4442, New Zealand



---

**From:** apply50max@noreply.nzta.govt.nz <apply50max@noreply.nzta.govt.nz>

**Sent:** Tuesday, 30 July 2019 8:51 AM

**To:** Apply 50 MAX <apply50MAX@nzta.govt.nz>

**Subject:** 50MAX application from Pacific Haulage Ltd - PHL45 40Q14 19-1412

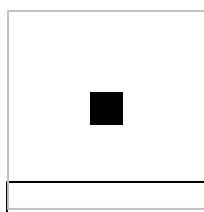

## A new 50MAX application has been received from the online form.

**TSL number:** s18(c)(1)  
**TSL company name:** Pacific Haulage Ltd  
**Email address:** s9(2)(a)  
**Contact name:** s9(2)(a)  
**Billing address:** 107 Aerodrome Road  
**Town/City:** Gisborne  
**Contact phone number:** s 9(2)(a)  
**Alternate phone number:**  
**Purchase order number/reference:** PHL45 & 40Q14

**Prime mover registration number:** PHL45  
**Vehicle combination 1, trailer 1 reg:** 40Q14 I do not have an HPMV permit to exceed length limits for this combination.  
**Vehicle combination 1, trailer 2 reg:**

**Overall length:** 23000 metres  
**First-to-last axle distance:** 20090 metres  
**Maximum Gross mass:** 50 tonnes  
**Load Type:** Logs  
**Journey Origin:** Gisborne  
**Journey Destination:** North Island

### Notes:

1. The NZ Transport Agency will invoice your NZTA account number the current fee for each permit issued from this application.  
The current fee is \$54.55 (excl. GST) per Permit issued. ((As specified in Schedule 4A of the Heavy Motor Vehicle Regulations 1974).
2. The above vehicle combination(s) are 50MAX Ready Pro Forma. You need to complete the relevant Pro Forma diagram for the vehicle combination(s) you are applying for and attached it to this application form. (You need only complete and submit one 50MAX Ready Pro Forma diagram with your application, as all trailers must be identical units. You can find the 50MAX Ready Pro Forma diagram at HPMV 50MAX Pro forma vehicle design).
3. Each of the above vehicle combination(s) requires a 50MAX Vehicle Combination Attribute Check Sheet that has been certified by a NZ Transport Agency appointed Certifier. Please attach a copy of these to this application form.
4. To operate this vehicle combination legally, you must have a current, valid High Productivity Motor Vehicle Permit to Exceed Length Limits for the vehicle combination(s).
5. You must load the vehicle combination, at all times, according to the general mass, Class One mass limits on individual axles, axle sets and combinations of axles as prescribed by the Vehicle Dimension and Mass Rule Schedule 2, Part A, Tables 1 to 5 and Table 6 extended for 50MAX. The Tables will be provided in your Permit as part of the permit Terms and Conditions.
6. Compliance with 5 above may mean, for some loads, you will be unable to load to the maximum gross mass you are permitted to load up to.
7. The above vehicle combination cannot operate with a gross mass exceeding 44 tonnes across any structure or roads restricted under the conditions of the permit.
8. The above vehicle combination cannot operate on any Local Authority road network restricted under the conditions of the permit.
9. If you wish to operate the vehicle combination on any Local Authority road network that is restricted under the conditions of the permit, you must apply to the Local Road Controlling Authority for a full High Productivity Motor

Vehicle Permit to Exceed Mass Limits and are legally bound to operate the vehicle combination under the terms and conditions of their permit within the boundary of their area of Authority.

10. You cannot operate the vehicle combination with a gross mass exceeding 44 tonnes in any Region other than what has been permitted.
11. This information requested is required to process an application for a 50MAX High Productivity Motor Vehicle Permit under the Land Transport Rule: Vehicle Dimensions and Mass 2002. The information that you provide as part of this application will be stored on, and form part of, the 50MAX Permit Register. The NZ Transport Agency may use the information for the purposes of monitoring and regulating operator behaviour. The Transport Agency may also disclose the information to Road Controlling Authorities for the purposes of network maintenance and operations.

The Privacy Act 1993, and the Official Information Act 1982, provides you with the right to access and correct any readily retrievable personal information held about you, or your company, respectively, by the Transport Agency.

Should you wish to exercise this right, please contact the NZ Transport Agency, Private Bag 11777, Palmerston North 4442 or email [info@nzta.govt.nz](mailto:info@nzta.govt.nz).

## Declaration and signatory

I declare that the particulars contained in this application are true and correct.

I confirm I have read and understood all the notes in this application form.

**Declared name:** s9(2)(a) [REDACTED]

-----  
This is an auto-generated email. Please do not reply, no-one will see it.

- *The NZTA Website*

The customer received a copy of this email.

Released under the Official Information Act 1982

# 50MAX: Permit for high-productivity motor vehicle (HPMV) to exceed mass limits

UNDER Section 5 of Land Transport Rule: Vehicle Dimensions and Mass 2016 (the Rule)

Permit number 50MAX-HPMV-19-24016

TSL number: **s18(c)(i)** TSL company name: PACIFIC HAULAGE LIMITED  
is hereby authorised to use the vehicle combination(s):

Registration Truck: PHL37 Trailer 1: 7P447 Trailer 2:  
numbers:

for high productivity motor vehicle trips to carry divisible loads with general access to the roads, subject to the region of travel restrictions specified in *Conditions for routes and structures* section of this permit, and subject to the conditions and maximum mass limits in this permit. The above vehicle combination (s) has a minimum of nine (9) axles in the axle configuration displayed in the diagram below.

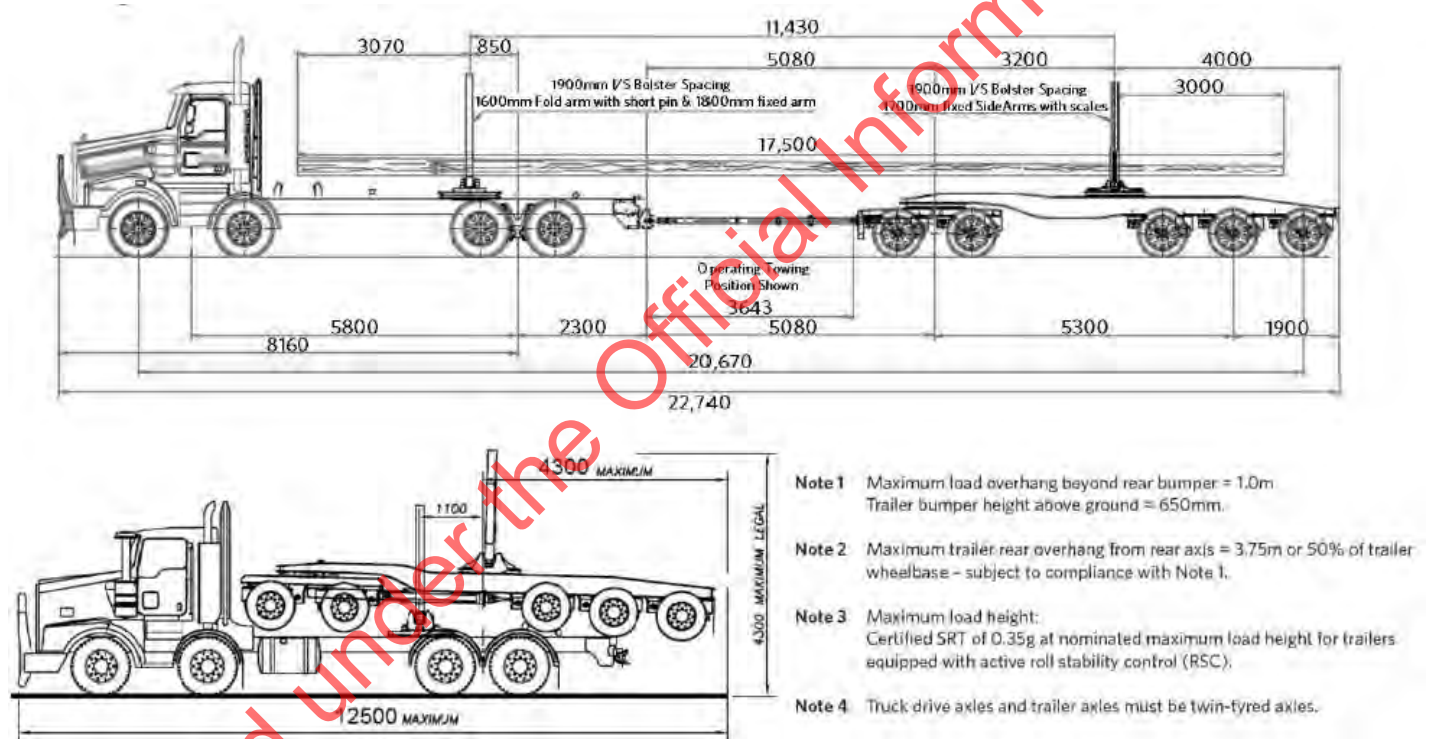

## Maximum gross mass

The maximum permitted gross mass is 50,000 kilograms.

## Length first to last axle

Length first to last axle of 20.670 metres and a maximum overall length of 22.740 metres.

## Validity

This permit is valid for high productivity motor vehicle trips from 19/07/2019 to 19/07/2021.

## Requirement to observe permit conditions

This permit is invalid if:

1. The vehicle is off-route, unless directed to do so by NZ Police or the road controlling authority
2. The permit is altered without authority

3. The vehicles or persons operating the vehicles are not those described on the permit.

## Critical conditions

The vehicle combination(s) must not:

4. Exceed the maximum permitted gross weight of 50,000 kilograms.
5. Exceed design limits, such as GVM.
6. Breach a travel restriction or requirement for a specific bridge or culvert specified in 11-14 below.

## Additional conditions

7. Trailer Roll Stability Control (RSC): The trailer(s) if first registered on or after 1 May 2010 must have roll stability control fitted and active; that is an Electronic Brake System (EBS) with the roll stability control function turned on. Alternatively if the trailer(s) were first registered before 1 May 2010 or are log trailers carting round wood first registered before 1 April 2016 and do not have EBS and RSC - these must instead operate with a minimum Static Roll Threshold (SRT) of 0.4 g, provided SRT compliance documentation is kept with this permit and produced to enforcement officers.
8. This permit must be carried in the vehicle and must be surrendered for inspection on the demand of any enforcement officer, or an authorised agent of NZ Transport Agency or a road controlling authority.
9. *Separate plant*: the towing of separate items of plant or equipment not specifically listed by registration number on this permit is not permitted.

## Revocation

10. This permit can be revoked under clause 5.7 of the Rule.
11. A breach in any of the conditions found in a permit may result in a revocation of the permit.

## Conditions routes and structures

12. Travel is permitted as defined by the *50MAX book of maps* and conditions 12, 13 and 14 and 15 below.
13. The vehicle combination(s) operating under this permit is permitted to travel on all roads in the Island(s) specified in condition 20 of this permit subject to the restrictions specified in the current version of the *50MAX book of maps*.
14. The vehicle combination(s) operating under this permit must not cross any restricted structures listed in the current version of the *50MAX book of maps* and must also comply with any other restrictions imposed by a road controlling authority on roads or structures under its control (for example, individual bridge postings).
15. This permit does not apply to travel on any noted as restricted or limited the current version of the *50MAX book of maps*.

## General terms

16. The vehicle shall not be operated on a road or bridge under this permit when in the opinion of the Road Controlling Authority, it is necessary for protection of infrastructure, or safety of road users, to prohibit the vehicle from travel on that road or bridge.

---

Authorised Issuing Officer

s9(2)(a)

Angela Short  
Senior Customer Access Representative on behalf of the NZ Transport Agency  
Date of Issue: 2/07/2019

---

## Notes

IMPORTANT: 50MAX permits allow for considerable additional access to the network for increased mass road transport. The resulting gains in economic efficiency must be achieved with due consideration for the safety of road users. It is therefore important that operators respect this permit and take on a level of self monitoring and compliance which will ensure the confidence of the travelling public in the road transport industry. The Transport Agency is aware that a number of operators

are investing in speed limiting, GPS monitoring, load cells, electronic stability control, ERUC and other safety measures. The Transport Agency recommends that all road transport operators consider the use of such available technology where it is applicable.

17. *Weighing*: enforcement officers are authorised to divert vehicles up to five kilometres from the approved route for the purpose of weighing, provided the diversion does not cross under-strength bridges.
18. *Identification sign*: the vehicle shall display a high-productivity motor vehicle sign in accordance with section 5.10 of the Rule when operating as a high-productivity motor vehicle.
19. *Overlength*: an overlength permit is required in addition to this authorisation if the vehicle exceeds the dimension limits in section 4 of the VDAM Rule. Further information about permits to exceed length limits can be found on the NZ Transport Agency website [www.nzta.govt.nz/](http://www.nzta.govt.nz/).
20. *Regional travel and restricted structures*:
  - a. The operator must ensure that they (and the driver of the vehicle) are using and comply with the current version of the *50MAX book of maps* published by the NZ Transport Agency at [www.nzta.govt.nz/commercial-driving/permits/high-productivity/50max/50max-information-for-operators-and-manufacturers/](http://www.nzta.govt.nz/commercial-driving/permits/high-productivity/50max/50max-information-for-operators-and-manufacturers/).
  - b. The current version of the *50MAX book of maps* is "The 50MAX Book of Maps version that applies at the time the vehicle is operating on the road, as described below. The current version can be found here <https://www.nzta.govt.nz/commercial-driving/high-productivity/50max/50max-information-for-operators-and-manufacturers/map-of-50max-routes/>
  - c. If the NZ Transport Agency issues a new version of the *50MAX book of maps*, it will publish the new version on the webpage specified above at least 5 business days before the first day of each calendar month and the new version shall take effect on the first day of each calendar month. If no new version is published prior to the first of the month, the latest published version remains in force. Business day - means a day other than a Saturday, a Sunday, or a public holiday (as defined in the Holidays Act 2003).  
  
Each version of the *50MAX book of maps* applies during the period beginning on the first day of the month of the year specified in the version name and ending on the last day of that month, unless no version for the following month is published by the Transport Agency in which case the latest published version remains in force.
  - d. For travel on the road network of a restricted road controlling authority, the vehicle must hold a HPMV permit issued by that road controlling authority. The vehicle combination is subject to all of the terms and conditions of the HPMV permit issued by the road controlling authority when operating on the roads under its control.
21. This permit does not exempt the holder from complying with all other acts, regulations and other laws (including those relating to certificate of loading and road user charges). Breaches of the conditions of the permit may also constitute offences in the terms of the Land Transport Act 1998.

**From:** [Apply 50 MAX](#)  
**To:** s9(2)(a)  
**Subject:** RE: Pacific Haulage Ltd - PHL37 7P447 19/07  
**Date:** Tuesday, 2 July 2019 2:47:00 PM  
**Attachments:** [Pacific Haulage Ltd - PHL37 7P447 1907.msg](#)  
[1 Heavy RUC info sheet 0217.pdf](#)  
[50MAX-HPMV-19-24016.pdf](#)  
[image001.jpg](#)  
[image002.png](#)  
[image003.png](#)

---

Congratulations your application for a 50MAX Permit has been approved. We've attached your Permit for your reference.

#### **What do you need to do next?**

Follow the instructions in the Heavy Info Sheet (attached) to ensure the correct Road User Charges (RUC) licence has been purchased, and therefore enable you to operate legally on the road.

**Please note that from 1 June 2017 we will now be issuing one network permit which will cover you for the entire 50MAX network.**

<http://www.nzta.govt.nz/about-us/news-and-media/keeping-connected/50max-carrying-more-nz-freight/>

Below are the links to Operator Safety Checks and the link to your Book of Maps.

<https://www.nzta.govt.nz/commercial-driving/high-productivity/hpmv-operator-safety-checks/>

**Please take the time to check the permit for accuracy and to read all of the supporting documentation and notes below.**

Remember: If the local road controlling authority (RCA) has not delegated authority to the Transport Agency (refer to the Restricted RCA tables in the book of maps) to issue 50MAX permits, then you will need to apply for an HPMV route permit for the access you need directly from that RCA.

#### About your Book of Maps:

1. You can access and download your Book of Maps online at <http://www.nzta.govt.nz/commercial-driving/high-productivity/50max/50max-information-for-operators-and-manufacturers/>
2. The Book of Maps will change as local authority networks are opened to 50MAX and restricted structures are upgraded and can be removed from the restricted list. Changes may also include structures being added to the restricted list from time to time.
3. Updates to the Book of Maps will occur on a monthly basis. You can access and download your updated Book of Maps online at <http://www.nzta.govt.nz/commercial-driving/high-productivity/50max/50max-information-for-operators-and-manufacturers/>
4. Where an unrestricted road network or structure changes to restricted, the 50MAX website will be updated at



<http://www.nzta.govt.nz/commercial-driving/high-productivity/50max/50max-information-for-operators-and-manufacturers/>

5. It is your responsibility to ensure you operate using the current Book of Maps at all times. Failure to do so is considered a breach of the Permit Terms and Conditions and will result in penalties.

Useful Tips for Using Your 50MAX Permit:

- It might be a good idea to laminate the pages (2-sided in one) of your Permit so that it is more durable under weather conditions and coffees
- Pop a printed copy of the Book of Maps into a Clearlite folder and carry it in the cab of your vehicle for easy reference
- Soon, you will be able to access online interactive 50MAX maps via a web browser, which will enable you to drill down to a low level when planning your journey.
- If you have a mobile device (i.e. tablet or Smartphone) you could download the current Book of Maps and the permit document(s) as a PDF file to this device

From 1 February 2017, the rules governing heavy vehicle size, weight and operation limits are changing. Please refer to the link below for further information.

<http://www.nzta.govt.nz/commercial-driving/vdam-what-you-need-to-know>

If you have any queries about your permit please contact us on [info50MAX@nzta.govt.nz](mailto:info50MAX@nzta.govt.nz) or phone 0800 699 000. Please do not reply to this email as your queries cannot be processed via this channel, thank you.

Regards,

Alex Scott / Senior Customer Access Representative  
Permitting Assessments

PH 0800 683 774

E [alexander.scott@nzta.govt.nz](mailto:alexander.scott@nzta.govt.nz) / w [nzta.govt.nz](http://nzta.govt.nz)

Palmerston North Office  
Private Bag 11777, Palmerston North 4442, New Zealand



---

**From:** renew50max@noreply.nzta.govt.nz <renew50max@noreply.nzta.govt.nz>

**Sent:** Wednesday, 26 June 2019 10:39 AM

**To:** Apply 50 MAX <apply50MAX@nzta.govt.nz>

**Subject:** Pacific Haulage Ltd - PHL37 7P447 19/07

**TSL number**

s18(c)(i)

**TSL company name (must match the full name recorded against the TSL number)**

Pacific Haulage Ltd

**Email address**

s9(2)(a)

**Confirm email address**

s9(2)(a)

**Billing address**

107 Aerodrome Road, Matawhero

**Town/City**

Gisborne

**Contact phone number**

s 9(2)(a)

**Alternative phone number**

**Purchase order number or reference (this will appear on your invoice)**

50MAX-HPMV-17-14821

**Contact name**

s9(2)(a)

**Permit number of the permit(s) that you want to renew**

50MAX-HPMV-17-14821

**Please upload a copy of the permit that you want to renew**

50MAX-HPMV-17-14821.pdf - [Download File](#)

**Please upload a copy of the second permit that you want to renew (if applicable)**

**Please tick the tick-box to indicate you agree with the declaration**

Yes

**Name**

s9(2)(a)

Released under the Official Information Act 1982

# 50MAX: Permit for high-productivity motor vehicle (HPMV) to exceed mass limits

UNDER Section 5 of Land Transport Rule: Vehicle Dimensions and Mass 2016 (the Rule)

Permit number 50MAX-HPMV-19-25351

TSL number: s18(c)(i) TSL company name: PACIFIC HAULAGE LIMITED  
is hereby authorised to use the vehicle combination(s):

Registration Truck: PHL39  
numbers:

Trailer 1: 8A839

Trailer 2:

for high productivity motor vehicle trips to carry divisible loads with general access to the roads, subject to the region of travel restrictions specified in *Conditions for routes and structures* section of this permit, and subject to the conditions and maximum mass limits in this permit. The above vehicle combination(s) has a minimum of nine (9) axles in the axle configuration displayed in the diagram below.

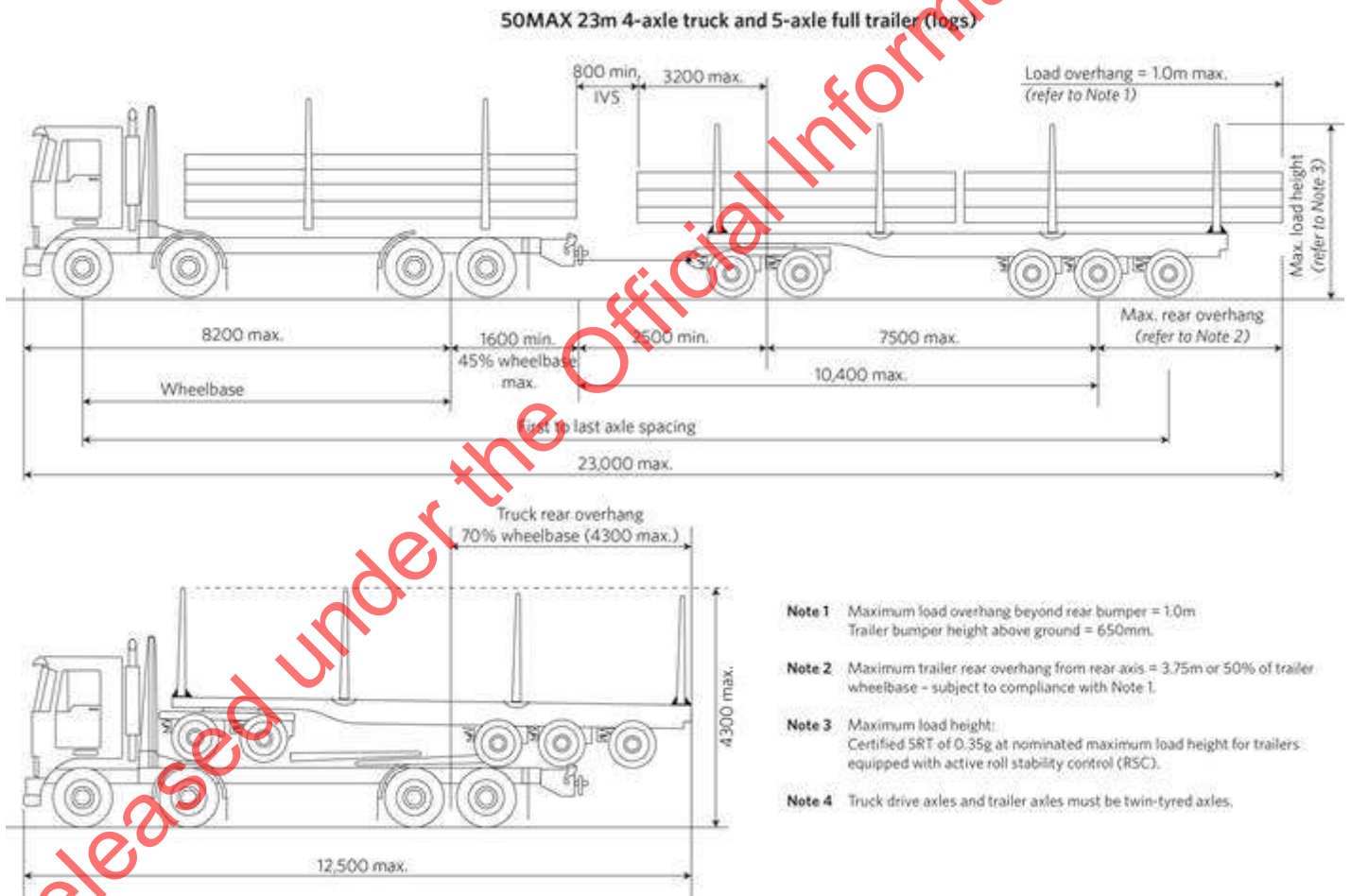

## Maximum gross mass

The maximum permitted gross mass is 50,000 kilograms.

## Length first to last axle

Length first to last axle of 20.090 metres and a maximum overall length of 23.000 metres.

## Validity

This permit is valid for high productivity motor vehicle trips from 3/10/2019 to 3/10/2021.

## Requirement to observe permit conditions

This permit is invalid if:

1. The vehicle is off-route, unless directed to do so by NZ Police or the road controlling authority
2. The permit is altered without authority
3. The vehicles or persons operating the vehicles are not those described on the permit.

## Critical conditions

The vehicle combination(s) must not:

4. Exceed the maximum permitted gross weight of 50,000 kilograms.
5. Exceed design limits, such as GVM.
6. Breach a travel restriction or requirement for a specific bridge or culvert specified in 11-14 below.

## Additional conditions

7. Trailer Roll Stability Control (RSC): The trailer(s) if first registered on or after 1 May 2010 must have roll stability control fitted and active; that is an Electronic Brake System (EBS) with the roll stability control function turned on. Alternatively if the trailer(s) were first registered before 1 May 2010 or are log trailers carrying round wood first registered before 1 April 2016 and do not have EBS and RSC - these must instead operate with a minimum Static Roll Threshold (SRT) of 0.4 g, provided SRT compliance documentation is kept with this permit and produced to enforcement officers.
8. This permit must be carried in the vehicle and must be surrendered for inspection on the demand of any enforcement officer, or an authorised agent of NZ Transport Agency or a road controlling authority.
9. *Separate plant*: the towing of separate items of plant or equipment not specifically listed by registration number on this permit is not permitted.

## Revocation

10. This permit can be revoked under clause 5.7 of the Rule.
11. A breach in any of the conditions found in a permit may result in a revocation of the permit.

## Conditions routes and structures

12. Travel is permitted as defined by the 50MAX book of maps and conditions 12, 13 and 14 and 15 below.
13. The vehicle combination(s) operating under this permit is permitted to travel on all roads in the Island(s) specified in condition 20 of this permit subject to the restrictions specified in the current version of the 50MAX book of maps.
14. The vehicle combination(s) operating under this permit must not cross any restricted structures listed in the current version of the 50MAX book of maps and must also comply with any other restrictions imposed by a road controlling authority on roads or structures under its control (for example, individual bridge postings).
15. This permit does not apply to travel on any noted as restricted or limited the current version of the 50MAX book of maps.

## General terms

16. The vehicle shall not be operated on a road or bridge under this permit when in the opinion of the Road Controlling Authority, it is necessary for protection of infrastructure, or safety of road users, to prohibit the vehicle from travel on that road or bridge.

---

Authorised Issuing Officer

s9(2)(a)

Angela Short  
Senior Customer Access Representative on behalf of the NZ Transport Agency  
Date of Issue: 25/09/2019

## Notes

IMPORTANT: 50MAX permits allow for considerable additional access to the network for increased mass road transport. The resulting gains in economic efficiency must be achieved with due consideration for the safety of road users. It is therefore important that operators respect this permit and take on a level of self monitoring and compliance which will ensure the confidence of the travelling public in the road transport industry. The Transport Agency is aware that a number of operators are investing in speed limiting, GPS monitoring, load cells, electronic stability control, ERUC and other safety measures. The Transport Agency recommends that all road transport operators consider the use of such available technology where it is applicable.

17. *Weighing*: enforcement officers are authorised to divert vehicles up to five kilometres from the approved route for the purpose of weighing, provided the diversion does not cross under-strength bridges.
18. *Identification sign*: the vehicle shall display a high-productivity motor vehicle sign in accordance with section 5.10 of the Rule when operating as a high-productivity motor vehicle.
19. *Overlength*: an overlength permit is required in addition to this authorisation if the vehicle exceeds the dimension limits in section 4 of the VDAM Rule. Further information about permits to exceed length limits can be found on the NZ Transport Agency website [www.nzta.govt.nz/](http://www.nzta.govt.nz/).
20. *Regional travel and restricted structures*:
  - a. The operator must ensure that they (and the driver of the vehicle) are using and comply with the current version of the *50MAX book of maps* published by the NZ Transport Agency at [www.nzta.govt.nz/commercial-driving/permits/high-productivity/50max/50max-information-for-operators-and-manufacturers/](http://www.nzta.govt.nz/commercial-driving/permits/high-productivity/50max/50max-information-for-operators-and-manufacturers/).
  - b. The current version of the *50MAX book of maps* is "The 50MAX Book of Maps version that applies at the time the vehicle is operating on the road, as described below. The current version can be found here <https://www.nzta.govt.nz/commercial-driving/high-productivity/50max/50max-information-for-operators-and-manufacturers/map-of-50max-routes/>
  - c. If the NZ Transport Agency issues a new version of the *50MAX book of maps*, it will publish the new version on the webpage specified above at least 5 business days before the first day of each calendar month and the new version shall take effect on the first day of each calendar month. If no new version is published prior to the first of the month, the latest published version remains in force. Business day – means a day other than a Saturday, a Sunday, or a public holiday (as defined in the Holidays Act 2003).

Each version of the *50MAX book of maps* applies during the period beginning on the first day of the month of the year specified in the version name and ending on the last day of that month, unless no version for the following month is published by the Transport Agency in which case the latest published version remains in force.

- d. For travel on the road network of a restricted road controlling authority, the vehicle must hold a HPMV permit issued by that road controlling authority. The vehicle combination is subject to all of the terms and conditions of the HPMV permit issued by the road controlling authority when operating on the roads under its control.
21. This permit does not exempt the holder from complying with all other acts, regulations and other laws (including those relating to certificate of loading and road user charges). Breaches of the conditions of the permit may also constitute offences in the terms of the Land Transport Act 1998.

**From:** [Apply 50 MAX](#)  
**To:** s9(2)(a)  
**Subject:** RE: Pacific Haulage Ltd - PHL39 8A839 03/10  
**Date:** Wednesday, 25 September 2019 4:39:00 PM  
**Attachments:** [Pacific Haulage Ltd - PHL39 8A839 0310.msg](#)  
[1 Heavy RUC info sheet 0217.pdf](#)  
[50MAX-HPMV-19-25351.pdf](#)  
[image001.jpg](#)  
[image002.png](#)  
[image003.png](#)

---

Congratulations your application for a 50MAX Permit has been approved. We've attached your Permit for your reference.

#### **What do you need to do next?**

Follow the instructions in the Heavy Info Sheet (attached) to ensure the correct Road User Charges (RUC) licence has been purchased, and therefore enable you to operate legally on the road.

**Please note that from 1 June 2017 we will now be issuing one network permit which will cover you for the entire 50MAX network.**

<http://www.nzta.govt.nz/about-us/news-and-media/keeping-connected/50max-carrying-more-nz-freight/>

Below are the links to Operator Safety Checks and the link to your Book of Maps.

<https://www.nzta.govt.nz/commercial-driving/high-productivity/hpmv-operator-safety-checks/>

**Please take the time to check the permit for accuracy and to read all of the supporting documentation and notes below.**

Remember: If the local road controlling authority (RCA) has not delegated authority to the Transport Agency (refer to the Restricted RCA tables in the book of maps) to issue 50MAX permits, then you will need to apply for an HPMV route permit for the access you need directly from that RCA.

#### About your Book of Maps:

1. You can access and download your Book of Maps online at <http://www.nzta.govt.nz/commercial-driving/high-productivity/50max/50max-information-for-operators-and-manufacturers/>
2. The Book of Maps will change as local authority networks are opened to 50MAX and restricted structures are upgraded and can be removed from the restricted list. Changes may also include structures being added to the restricted list from time to time.
3. Updates to the Book of Maps will occur on a monthly basis. You can access and download your updated Book of Maps online at <http://www.nzta.govt.nz/commercial-driving/high-productivity/50max/50max-information-for-operators-and-manufacturers/>
4. Where an unrestricted road network or structure changes to restricted, the 50MAX website will be updated at

<http://www.nzta.govt.nz/commercial-driving/high-productivity/50max/50max-information-for-operators-and-manufacturers/>

5. It is your responsibility to ensure you operate using the current Book of Maps at all times. Failure to do so is considered a breach of the Permit Terms and Conditions and will result in penalties.

Useful Tips for Using Your 50MAX Permit:

- It might be a good idea to laminate the pages (2-sided in one) of your Permit so that it is more durable under weather conditions and coffees
- Pop a printed copy of the Book of Maps into a Clearlite folder and carry it in the cab of your vehicle for easy reference
- Soon, you will be able to access online interactive 50MAX maps via a web browser, which will enable you to drill down to a low level when planning your journey.
- If you have a mobile device (i.e. tablet or Smartphone) you could download the current Book of Maps and the permit document(s) as a PDF file to this device

From 1 February 2017, the rules governing heavy vehicle size, weight and operation limits are changing. Please refer to the link below for further information.

<http://www.nzta.govt.nz/commercial-driving/vdam-what-you-need-to-know>

If you have any queries about your permit please contact us on [info50MAX@nzta.govt.nz](mailto:info50MAX@nzta.govt.nz) or phone 0800 699 000. Please do not reply to this email as your queries cannot be processed via this channel, thank you.

Regards,

Alex Scott / Senior Customer Access Representative  
Permitting Assessments

PH 0800 683 774

E [alexander.scott@nzta.govt.nz](mailto:alexander.scott@nzta.govt.nz) / w [nzta.govt.nz](http://nzta.govt.nz)

Palmerston North Office  
Private Bag 11777, Palmerston North 4442, New Zealand



**From:** [renew50max@noreply.nzta.govt.nz](mailto:renew50max@noreply.nzta.govt.nz) <[renew50max@noreply.nzta.govt.nz](mailto:renew50max@noreply.nzta.govt.nz)>

**Sent:** Thursday, 19 September 2019 11:33 AM

**To:** Apply 50 MAX <[apply50MAX@nzta.govt.nz](mailto:apply50MAX@nzta.govt.nz)>

**Subject:** Pacific Haulage Ltd - PHL39 8A839 03/10

**TSL number**

§18(c)  
(h)

**TSL company name (must match the full name recorded against the TSL number)**

Pacific Haulage Ltd

**Email address**

s9(2)(a)

**Confirm email address**

s9(2)(a)

**Billing address**

107 Aerodrome Road

**Town/City**

Matawhero, Gisborne

**Contact phone number**

s 9(2)(a)

**Alternative phone number**

**Purchase order number or reference (this will appear on your invoice)**

PHL39 & 8A839

**Contact name**

s9(2)(a)

**Permit number of the permit(s) that you want to renew**

50MAX-HPMV-17-15587

**Please upload a copy of the permit that you want to renew**

50MAX-HPMV-17-15587.pdf - [Download File](#)

**Please upload a copy of the second permit that you want to renew (if applicable)**

**Please tick the tick-box to indicate you agree with the declaration**

Yes

**Name**

s9(2)(a)

Released under the Official Information Act 1982



**From:** [Apply 50 MAX](#)  
**To:** s9(2)(a)  
**Subject:** RE: Pacific Haulage Ltd PHL25 7B837  
**Date:** Tuesday, 16 April 2019 1:34:00 PM  
**Attachments:** [Pacific Haulage Ltd PHL25 7B837.msg](#)  
[1 Heavy RUC info sheet 0217.pdf](#)  
[50MAX-HPMV-19-22851.pdf](#)  
[image001.jpg](#)  
[image002.png](#)  
[image003.png](#)

---

Congratulations your application for a 50MAX Permit has been approved. We've attached your Permit for your reference.

#### **What do you need to do next?**

Follow the instructions in the Heavy Info Sheet (attached) to ensure the correct Road User Charges (RUC) licence has been purchased, and therefore enable you to operate legally on the road.

**Please note that from 1 June 2017 we will now be issuing one network permit which will cover you for the entire 50MAX network.**

<http://www.nzta.govt.nz/about-us/news-and-media/keeping-connected/50max-carrying-more-nz-freight/>

Below are the links to Operator Safety Checks and the link to your Book of Maps.

<https://www.nzta.govt.nz/commercial-driving/high-productivity/hpmv-operator-safety-checks/>

**Please take the time to check the permit for accuracy and to read all of the supporting documentation and notes below.**

Remember: If the local road controlling authority (RCA) has not delegated authority to the Transport Agency (refer to the Restricted RCA tables in the book of maps) to issue 50MAX permits, then you will need to apply for an HPMV route permit for the access you need directly from that RCA.

About your Book of Maps:

1. You can access and download your Book of Maps online at <http://www.nzta.govt.nz/commercial-driving/high-productivity/50max/50max-information-for-operators-and-manufacturers/>
2. The Book of Maps will change as local authority networks are opened to 50MAX and restricted structures are upgraded and can be removed from the restricted list. Changes may also include structures being added to the restricted list from time to time.
3. Updates to the Book of Maps will occur on a monthly basis. You can access and download your updated Book of Maps online at <http://www.nzta.govt.nz/commercial-driving/high-productivity/50max/50max-information-for-operators-and-manufacturers/>
4. Where an unrestricted road network or structure changes to restricted, the 50MAX website will be updated at

<http://www.nzta.govt.nz/commercial-driving/high-productivity/50max/50max-information-for-operators-and-manufacturers/>

5. It is your responsibility to ensure you operate using the current Book of Maps at all times. Failure to do so is considered a breach of the Permit Terms and Conditions and will result in penalties.

Useful Tips for Using Your 50MAX Permit:

- It might be a good idea to laminate the pages (2-sided in one) of your Permit so that it is more durable under weather conditions and coffees
- Pop a printed copy of the Book of Maps into a Clearlite folder and carry it in the cab of your vehicle for easy reference
- Soon, you will be able to access online interactive 50MAX maps via a web browser, which will enable you to drill down to a low level when planning your journey.
- If you have a mobile device (i.e. tablet or Smartphone) you could download the current Book of Maps and the permit document(s) as a PDF file to this device

From 1 February 2017, the rules governing heavy vehicle size, weight and operation limits are changing. Please refer to the link below for further information.

<http://www.nzta.govt.nz/commercial-driving/vdam-what-you-need-to-know>

If you have any queries about your permit please contact us on [info50MAX@nzta.govt.nz](mailto:info50MAX@nzta.govt.nz) or phone 0800 699 000. Please do not reply to this email as your queries cannot be processed via this channel, thank you.

Regards,

Alex Scott / Senior Customer Access Representative  
Permitting Assessments

PH 0800 683 774

E [alexander.scott@nzta.govt.nz](mailto:alexander.scott@nzta.govt.nz) / w [nzta.govt.nz](http://nzta.govt.nz)

Palmerston North Office  
Private Bag 11777, Palmerston North 4442, New Zealand



---

**From:** renew50max@noreply.nzta.govt.nz <renew50max@noreply.nzta.govt.nz>

**Sent:** Friday, 12 April 2019 10:52 AM

**To:** Apply 50 MAX <apply50MAX@nzta.govt.nz>

**Subject:** Pacific Haulage Ltd PHL25 7B837

**TSL number**

s18(c)  
(i)

**TSL company name (must match the full name recorded against the TSL number)**

Pacific Haulage Ltd

**Email address**

s9(2)(a)

**Confirm email address**

s9(2)(a)

**Billing address**

107 Aerodrome Road

**Town/City**

Gisborne

**Contact phone number**

s 9(2)(a)

**Alternative phone number**

**Purchase order number or reference (this will appear on your invoice)**

PHL25 & 7B837

**Contact name**

s9(2)(a)

**Permit number of the permit(s) that you want to renew**

50MAX-HPMV-17-13710

**Please upload a copy of the permit that you want to renew**

50MAX-HPMV-17-13710.pdf - [Download File](#)

**Please upload a copy of the second permit that you want to renew (if applicable)**

**Please tick the tick-box to indicate you agree with the declaration**

Yes

**Name**

s9(2)(a)

Released under the Official Information Act 1982

## 50MAX: Permit for high-productivity motor vehicle (HPMV) to exceed mass limits

UNDER Section 5 of Land Transport Rule: Vehicle Dimensions and Mass 2016 (the Rule)

Permit number **50MAX-HPMV-17-13710**

TSL number: **50108** TSL company name: **PACIFIC HAULAGE LIMITED**

is hereby authorised to use the vehicle combination(s):

Registration numbers: Truck: **PHL25**

Trailer 1: **7B837**

Trailer 2:

for high productivity motor vehicle trips to carry divisible loads with general access to the roads, subject to the region of travel restrictions specified in *Conditions for routes and structures* section of this permit, and subject to the conditions and maximum mass limits in this permit. The above vehicle combination(s) has a minimum of nine (9) axles in the axle configuration displayed in the diagram below.

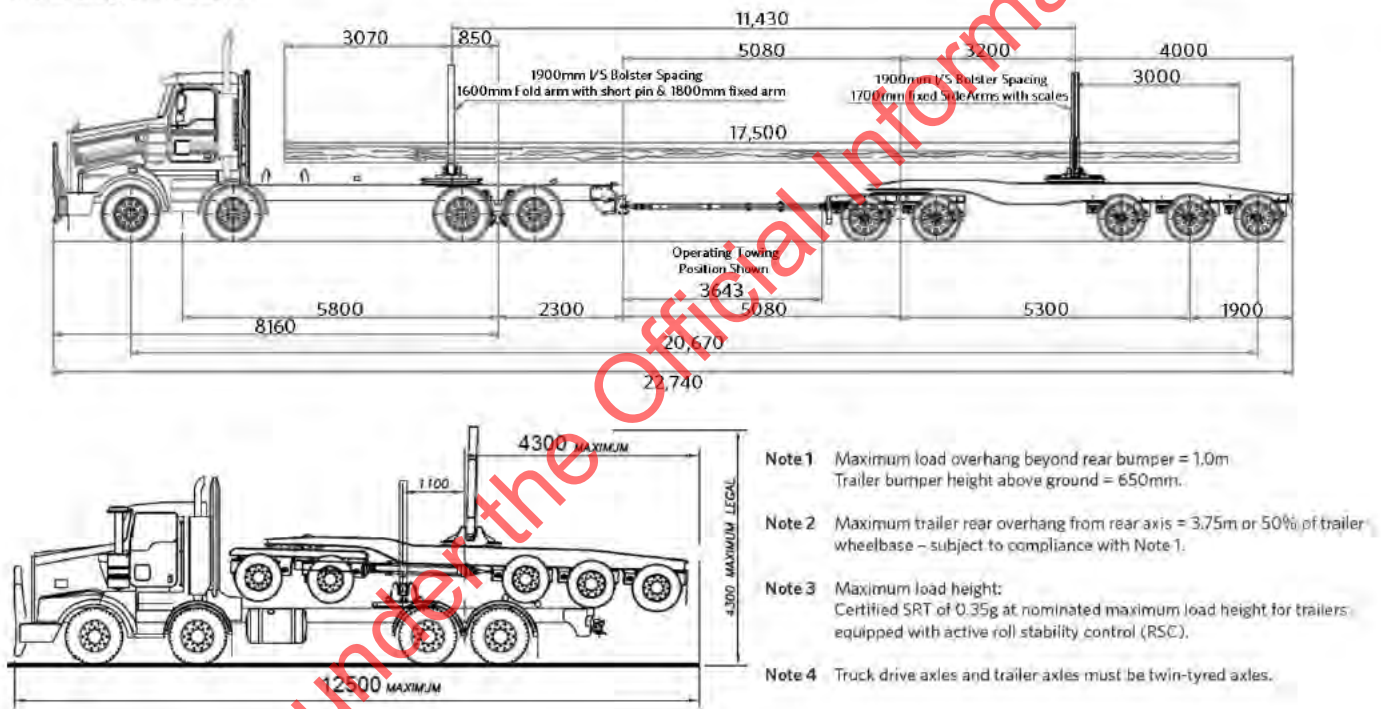

### Maximum gross mass

The maximum permitted gross mass is 50,000kg.

### Length first to last axle

Length first to last axle of **20.670 metres** and a maximum overall length of **22.740 metres**.

### Validity

This permit is valid for high productivity motor vehicle trips from **4/05/2017** to **4/05/2019**.

### Requirement to observe permit conditions

This permit is invalid if:

1. The vehicle is off-route, unless directed to do so by NZ Police or the road controlling authority
2. The permit is altered without authority
3. The vehicles or persons operating the vehicles are not those described on the permit.

#### Critical conditions

#### The vehicle combination(s) must not:

4. Exceed the maximum permitted gross weight of **50,000 kilograms**.
5. Exceed design limits, such as GVM.
6. Breach a travel restriction or requirement for a specific bridge or culvert specified in 11-14 below.

#### Additional conditions

7. Trailer Roll Stability Control (RSC): The trailer(s) if first registered on or after 1 May 2010 must have roll stability control fitted and active; that is an Electronic Brake System (EBS) with the roll stability control function turned on. Alternatively if the trailer(s) were first registered before 1 May 2010 or are log trailers carting round wood first registered before 1 April 2016 and do not have EBS and RSC – these must instead operate with a minimum Static Roll Threshold (SRT) of 0.4 g, provided SRT compliance documentation is kept with this permit and produced to enforcement officers.
8. This permit must be carried in the vehicle and must be surrendered for inspection on the demand of any enforcement officer, or an authorised agent of NZ Transport Agency or a road controlling authority.
9. *Separate plant*: the towing of separate items of plant or equipment not specifically listed by registration number on this permit is not permitted.

#### Revocation

10. This permit can be revoked under clause 5.7 of the Rule.

#### Conditions routes and structures

11. Travel is permitted in the **North Island** as defined by the *SOMAX book of maps* and conditions 12, 13 and 14 and 15 below.
12. The vehicle combination(s) operating under this permit is permitted to travel on all roads in the Island(s) specified in condition 11 of this permit subject to the restrictions specified in the current version of the *SOMAX book of maps*.
13. The vehicle combination(s) operating under this permit **must not cross** any restricted structures listed in the current version of the *SOMAX book of maps* and **must also comply** with any other restrictions imposed by a road controlling authority on roads or structures under its control (for example, individual bridge postings).
14. This permit **does not apply** to travel on any noted as restricted or limited the current version of the *SOMAX book of maps*.

#### General terms

15. The vehicle **shall not** be operated on a road or bridge under this permit when in the opinion of the Road Controlling Authority, it is necessary for protection of infrastructure, or safety of road users, to prohibit the vehicle from travel on that road or bridge.

---

#### Authorised Issuing Officer

s9(2)(a)

Lisa Wampana  
Customer Access Representative on behalf of the NZ Transport Agency

**Date of Issue:** 4/05/2017

---

## Notes

**IMPORTANT:** 50MAX permits allow for considerable additional access to the network for increased mass road transport. The resulting gains in economic efficiency must be achieved with due consideration for the safety of road users. It is therefore important that operators respect this permit and take on a level of self monitoring and compliance which will ensure the confidence of the travelling public in the road transport industry. The Transport Agency is aware that a number of operators are investing in speed limiting, GPS monitoring, load cells, electronic stability control, ERUC and other safety measures. The Transport Agency recommends that all road transport operators consider the use of such available technology where it is applicable.

16. *Weighing:* enforcement officers are authorised to divert vehicles up to five kilometres from the approved route for the purpose of weighing, provided the diversion does not cross under-strength bridges.
17. *Identification sign:* the vehicle shall display a high-productivity motor vehicle sign in accordance with section 9.10 of the Rule when operating as a high-productivity motor vehicle.
18. *Overlength:* an overlength permit is required **in addition** to this authorisation if the vehicle exceeds the dimension limits in section 4 of the VDAM Rule. Further information about permits to exceed length limits can be found on the NZ Transport Agency website [www.nzta.govt.nz/](http://www.nzta.govt.nz/).
19. *Regional travel and restricted structures:*
  - a. The operator must ensure that they (and the driver of the vehicle) are using and comply with the current version of the *50MAX book of maps* published by the NZ Transport Agency at [www.nzta.govt.nz/commercial-driving/permits/high-productivity/50max/50max-information-for-operators-and-manufacturers/](http://www.nzta.govt.nz/commercial-driving/permits/high-productivity/50max/50max-information-for-operators-and-manufacturers/).
  - b. The current version of the *50MAX book of maps* is "The 50MAX Book of Maps version: [month], [year]" that applies at the time the vehicle is operating on the road, as described below.
  - c. If the NZ Transport Agency issues a new version of the *50MAX book of maps*, it will publish the new version on the webpage specified above at least 5 business days before the first day of each calendar month and the new version shall take effect on the first day of each calendar month. If no new version is published prior to the first of the month, the latest published version remains in force. Business day – means a day other than a Saturday, a Sunday, or a public holiday (as defined in the Holidays Act 2003).

Each version of the *50MAX book of maps* applies during the period beginning on the first day of the month of the year specified in the version name and ending on the last day of that month, unless no version for the following month is published by the Transport Agency in which case the latest published version remains in force.
  - d. For travel on the road network of a restricted road controlling authority, the vehicle must hold a HPMV permit issued by that road controlling authority. The vehicle combination is subject to all of the terms and conditions of the HPMV permit issued by the road controlling authority when operating on the roads under its control.
21. This permit does not exempt the holder from complying with all other acts, regulations and other laws (including those relating to certificate of loading and road user charges). Breaches of the conditions of the permit may also constitute offences in the terms of the Land Transport Act 1998.

**From:** [renew50max@noreply.nzta.govt.nz](mailto:renew50max@noreply.nzta.govt.nz)  
**To:** [Apply 50 MAX](#)  
**Subject:** Pacific Haulage Ltd PHL36 6Y910 03/04  
**Date:** Wednesday, 27 March 2019 11:18:43 AM  
**Attachments:** [50MAX-HPMV-17-13326.pdf](#)

---

**TSL number**

s18(c)  
(b)

**TSL company name (must match the full name recorded against the TSL number)**

Pacific Haulage Ltd

**Email address**

s9(2)(a)

**Confirm email address**

s9(2)(a)

**Billing address**

107 Aerodrome Road

**Town/City**

Gisborne

**Contact phone number**

s 9(2)(a)

**Alternative phone number**

s 9(2)(a)

**Purchase order number or reference (this will appear on your invoice)**

PHL36 & 6Y910

**Contact name**

s9(2)(a)

**Permit number of the permit(s) that you want to renew**

50MAX-HPMV-17-13326

**Please upload a copy of the permit that you want to renew**

50MAX-Permit-PHL36-6Y910.pdf - [Download File](#)

**Please upload a copy of the second permit that you want to renew (if applicable)**

**Please tick the tick-box to indicate you agree with the declaration**

Yes

**Name**

s9(2)(a)

Released under the Official Information Act 1982

**From:** [Apply 50 MAX](#)  
**To:** s9(2)(a) "  
**Subject:** RE: Pacific Haulage Ltd PHL36 6Y910 03/04  
**Date:** Wednesday, 27 March 2019 5:40:00 PM  
**Attachments:** [Pacific Haulage Ltd PHL36 6Y910 0304.msg](#)  
[1 Heavy RUC info sheet 0217.pdf](#)  
[50MAX-HPMV-19-22660.pdf](#)  
[image001.jpg](#)  
[image002.png](#)  
[image003.png](#)

---

Congratulations your application for a 50MAX Permit has been approved. We've attached your Permit for your reference.

#### **What do you need to do next?**

Follow the instructions in the Heavy Info Sheet (attached) to ensure the correct Road User Charges (RUC) licence has been purchased, and therefore enable you to operate legally on the road.

**Please note that from 1 June 2017 we will now be issuing one network permit which will cover you for the entire 50MAX network.**

<http://www.nzta.govt.nz/about-us/news-and-media/keeping-connected/50max-carrying-more-nz-freight/>

Below are the links to Operator Safety Checks and the link to your Book of Maps.

<https://www.nzta.govt.nz/commercial-driving/high-productivity/hpmv-operator-safety-checks/>

**Please take the time to check the permit for accuracy and to read all of the supporting documentation and notes below.**

Remember: If the local road controlling authority (RCA) has not delegated authority to the Transport Agency (refer to the Restricted RCA tables in the book of maps) to issue 50MAX permits, then you will need to apply for an HPMV route permit for the access you need directly from that RCA.

#### About your Book of Maps:

1. You can access and download your Book of Maps online at <http://www.nzta.govt.nz/commercial-driving/high-productivity/50max/50max-information-for-operators-and-manufacturers/>
2. The Book of Maps will change as local authority networks are opened to 50MAX and restricted structures are upgraded and can be removed from the restricted list. Changes may also include structures being added to the restricted list from time to time.
3. Updates to the Book of Maps will occur on a monthly basis. You can access and download your updated Book of Maps online at <http://www.nzta.govt.nz/commercial-driving/high-productivity/50max/50max-information-for-operators-and-manufacturers/>
4. Where an unrestricted road network or structure changes to restricted, the 50MAX website will be updated at



<http://www.nzta.govt.nz/commercial-driving/high-productivity/50max/50max-information-for-operators-and-manufacturers/>

5. It is your responsibility to ensure you operate using the current Book of Maps at all times. Failure to do so is considered a breach of the Permit Terms and Conditions and will result in penalties.

Useful Tips for Using Your 50MAX Permit:

- It might be a good idea to laminate the pages (2-sided in one) of your Permit so that it is more durable under weather conditions and coffees
- Pop a printed copy of the Book of Maps into a Clearlite folder and carry it in the cab of your vehicle for easy reference
- Soon, you will be able to access online interactive 50MAX maps via a web browser, which will enable you to drill down to a low level when planning your journey.
- If you have a mobile device (i.e. tablet or Smartphone) you could download the current Book of Maps and the permit document(s) as a PDF file to this device

From 1 February 2017, the rules governing heavy vehicle size, weight and operation limits are changing. Please refer to the link below for further information.

<http://www.nzta.govt.nz/commercial-driving/vdam-what-you-need-to-know>

If you have any queries about your permit please contact us on [info50MAX@nzta.govt.nz](mailto:info50MAX@nzta.govt.nz) or phone 0800 699 000. Please do not reply to this email as your queries cannot be processed via this channel, thank you.

Regards,

Alex Scott / Senior Customer Access Representative  
Permitting Assessments

PH 0800 683 774

E [alexander.scott@nzta.govt.nz](mailto:alexander.scott@nzta.govt.nz) / w [nzta.govt.nz](http://nzta.govt.nz)

Palmerston North Office  
Private Bag 11777, Palmerston North 4442, New Zealand



---

**From:** renew50max@noreply.nzta.govt.nz <renew50max@noreply.nzta.govt.nz>

**Sent:** Wednesday, 27 March 2019 11:19 AM

**To:** Apply 50 MAX <apply50MAX@nzta.govt.nz>

**Subject:** Pacific Haulage Ltd PHL36 6Y910 03/04

**TSL number**

s18(c)  
(i)

**TSL company name (must match the full name recorded against the TSL number)**

Pacific Haulage Ltd

**Email address**

s9(2)(a)

**Confirm email address**

s9(2)(a)

**Billing address**

107 Aerodrome Road

**Town/City**

Gisborne

**Contact phone number**

s 9(2)(a)

**Alternative phone number**

s9(2)(a)

**Purchase order number or reference (this will appear on your invoice)**

PHL36 & 6Y910

**Contact name**

s9(2)(a)

**Permit number of the permit(s) that you want to renew**

50MAX-HPMV-17-13326

**Please upload a copy of the permit that you want to renew**

50MAX-Permit-PHL36-6Y910.pdf - [Download File](#)

**Please upload a copy of the second permit that you want to renew (if applicable)**

**Please tick the tick-box to indicate you agree with the declaration**

Yes

**Name**

s9(2)(a)

Released under the Official Information Act 1982

**From:** [Apply 50 MAX](#)  
**To:** s9(2)(a)  
**Subject:** RE: Pacific Haulage Ltd PHL38 7K728 22/06  
**Date:** Wednesday, 15 May 2019 4:40:00 PM  
**Attachments:** [Pacific Haulage Ltd PHL38 7K728 2206.msg](#)  
[1 Heavy RUC info sheet 0217.pdf](#)  
[50MAX-HPMV-19-23209.pdf](#)  
[image001.jpg](#)  
[image002.png](#)  
[image003.png](#)

---

Congratulations your application for a 50MAX Permit has been approved. We've attached your Permit for your reference.

#### **What do you need to do next?**

Follow the instructions in the Heavy Info Sheet (attached) to ensure the correct Road User Charges (RUC) licence has been purchased, and therefore enable you to operate legally on the road.

**Please note that from 1 June 2017 we will now be issuing one network permit which will cover you for the entire 50MAX network.**

<http://www.nzta.govt.nz/about-us/news-and-media/keeping-connected/50max-carrying-more-nz-freight/>

Below are the links to Operator Safety Checks and the link to your Book of Maps.

<https://www.nzta.govt.nz/commercial-driving/high-productivity/hpmv-operator-safety-checks/>

**Please take the time to check the permit for accuracy and to read all of the supporting documentation and notes below.**

Remember: If the local road controlling authority (RCA) has not delegated authority to the Transport Agency (refer to the Restricted RCA tables in the book of maps) to issue 50MAX permits, then you will need to apply for an HPMV route permit for the access you need directly from that RCA.

#### About your Book of Maps:

1. You can access and download your Book of Maps online at <http://www.nzta.govt.nz/commercial-driving/high-productivity/50max/50max-information-for-operators-and-manufacturers/>
2. The Book of Maps will change as local authority networks are opened to 50MAX and restricted structures are upgraded and can be removed from the restricted list. Changes may also include structures being added to the restricted list from time to time.
3. Updates to the Book of Maps will occur on a monthly basis. You can access and download your updated Book of Maps online at <http://www.nzta.govt.nz/commercial-driving/high-productivity/50max/50max-information-for-operators-and-manufacturers/>
4. Where an unrestricted road network or structure changes to restricted, the 50MAX website will be updated at

<http://www.nzta.govt.nz/commercial-driving/high-productivity/50max/50max-information-for-operators-and-manufacturers/>

5. It is your responsibility to ensure you operate using the current Book of Maps at all times. Failure to do so is considered a breach of the Permit Terms and Conditions and will result in penalties.

Useful Tips for Using Your 50MAX Permit:

- It might be a good idea to laminate the pages (2-sided in one) of your Permit so that it is more durable under weather conditions and coffees
- Pop a printed copy of the Book of Maps into a Clearlite folder and carry it in the cab of your vehicle for easy reference
- Soon, you will be able to access online interactive 50MAX maps via a web browser, which will enable you to drill down to a low level when planning your journey.
- If you have a mobile device (i.e. tablet or Smartphone) you could download the current Book of Maps and the permit document(s) as a PDF file to this device

From 1 February 2017, the rules governing heavy vehicle size, weight and operation limits are changing. Please refer to the link below for further information.

<http://www.nzta.govt.nz/commercial-driving/vdam-what-you-need-to-know>

If you have any queries about your permit please contact us on [info50MAX@nzta.govt.nz](mailto:info50MAX@nzta.govt.nz) or phone 0800 699 000. Please do not reply to this email as your queries cannot be processed via this channel, thank you.

Regards,

Alex Scott / Senior Customer Access Representative  
Permitting Assessments

PH 0800 683 774

E [alexander.scott@nzta.govt.nz](mailto:alexander.scott@nzta.govt.nz) / w [nzta.govt.nz](http://nzta.govt.nz)

Palmerston North Office  
Private Bag 11777, Palmerston North 4442, New Zealand



---

**From:** renew50max@noreply.nzta.govt.nz <renew50max@noreply.nzta.govt.nz>

**Sent:** Tuesday, 14 May 2019 2:45 PM

**To:** Apply 50 MAX <apply50MAX@nzta.govt.nz>

**Subject:** Pacific Haulage Ltd PHL38 7K728 22/06

**TSL number**

s18(c)  
(i)

**TSL company name (must match the full name recorded against the TSL number)**

Pacific Haulage Ltd

**Email address**

s9(2)(a)

**Confirm email address**

s9(2)(a)

**Billing address**

107 Aerodrome Road

**Town/City**

Gisborne

**Contact phone number**

s 9(2)(a)

**Alternative phone number**

**Purchase order number or reference (this will appear on your invoice)**

PHL38 & 7K728

**Contact name**

s9(2)(a)

**Permit number of the permit(s) that you want to renew**

50MAX-HPMV-17-14529

**Please upload a copy of the permit that you want to renew**

50MAX-HPMV-17-14529.pdf - [Download File](#)

**Please upload a copy of the second permit that you want to renew (if applicable)**

**Please tick the tick-box to indicate you agree with the declaration**

Yes

**Name**

s9(2)(a)

Released under the Official Information Act 1982

**From:** [renew50max@noreply.nzta.govt.nz](mailto:renew50max@noreply.nzta.govt.nz)  
**To:** [Apply 50 MAX](#)  
**Subject:** Pacific Haulage Ltd PHL38 7K728 22/06  
**Date:** Tuesday, 14 May 2019 2:44:52 PM  
**Attachments:** [50MAX-HPMV-17-14529.pdf](#)

---

**TSL number**

s18(c)(i)  
[REDACTED]

**TSL company name (must match the full name recorded against the TSL number)**

Pacific Haulage Ltd

**Email address**

s9(2)(a)  
[REDACTED]

**Confirm email address**

s9(2)(a)  
[REDACTED]

**Billing address**

107 Aerodrome Road

**Town/City**

Gisborne

**Contact phone number**

s 9(2)(a)  
[REDACTED]

**Alternative phone number**

**Purchase order number or reference (this will appear on your invoice)**

PHL38 & 7K728

**Contact name**

s9(2)(a)  
[REDACTED]

**Permit number of the permit(s) that you want to renew**

50MAX-HPMV-17-14529

**Please upload a copy of the permit that you want to renew**

50MAX-HPMV-17-14529.pdf - [Download File](#)

**Please upload a copy of the second permit that you want to renew (if applicable)**

**Please tick the tick-box to indicate you agree with the declaration**

Yes

**Name**

s9(2)(a)  
[REDACTED]

Released under the Official Information Act 1982

**From:** [Nathan Murrell](#)  
**To:** [Ben Gamboni](#)  
**Subject:** RE: PHL - new s198 draft  
**Date:** Tuesday, 4 June 2019 1:37:00 PM  
**Attachments:** [image001.png](#)  
[image002.jpg](#)  
[image003.jpg](#)  
[image004.jpg](#)  
[image005.jpg](#)  
[DRAFT\\_50108\\_Pacific\\_Haulage\\_Limited\\_s198\\_Request\\_20190527.docx](#)

---

Hi Ben,

I've spoken to s9(2)(a) and advised that we have found information to be missing from the submissions made by PHL.

He was surprised, and genuinely believed that they had submitted everything. He did note that for privacy reasons that they admit excluding the driver address and phone numbers out. I didn't go into that part any further with him.

I've created a fairly paired down s198 request that just fills in the gaps. If you could take a look and let me know what you think.

The main issues are :

- vehicle maintenance i.e. all we got were invoices, nothing in the way of actual records.
- Drug testing – noted in the one crash report, but no drug records submitted. I've widened this to 12 months.
- No driver contracts supplied. Have requested 6 specified by name.
- Any records of daily vehicle checks.

I told him I would email it to him by the end of the week and happy to discuss it if he had any issues.

If there is anything you feel needs changing i.e. date ranges etc, please let me know.

Cheers  
Nathan

---

**From:** Ben Gamboni  
**Sent:** Wednesday, 29 May 2019 10:57 AM  
**To:** Nathan Murrell <[Nathan.Murrell@nzta.govt.nz](mailto:Nathan.Murrell@nzta.govt.nz)>; Lynn Williams <[Lynn.Williams@nzta.govt.nz](mailto:Lynn.Williams@nzta.govt.nz)>; Neil McAlpine <[Neil.McAlpine@nzta.govt.nz](mailto:Neil.McAlpine@nzta.govt.nz)>; Robert Montgomery <[Robert.Montgomery@nzta.govt.nz](mailto:Robert.Montgomery@nzta.govt.nz)>  
**Subject:** RE: PHL - new s198 draft

Hi,

A couple of questions/comments from me:

- Why do we need drivers' home addresses and contact telephone numbers?
- Ask for a minimum of 6x employment contracts rather than all of them. We don't need to check every single one and that makes the process a bit easier for us and

them.

- It may be worthwhile removing the requirement for the crash/incident reports in order to make this 198 request more focused. We've seen a copy of how they investigate and report on these incidents. Perhaps we could go down this path further down the line but at the moment let's focus on fatigue and speed/driving behaviour primarily. If there was a piece of info that was missing from the report that has been sent then ask for that specifically.
- Can we remove the requests for info that has already been supplied? (Not sure if it has but I don't want to go out and ask for everything again when they've already supplied some of it).

This request needs a phone call first as a courtesy to s9(2)(a) to explain in really simple terms what we've found so far in general terms i.e. we have some concerns around fatigue and vehicle maintenance as a result of our initial analysis but we aren't able to finalise our findings until we look at the information that wasn't supplied e.g. speed data etc. Let him know that we'll send that request out asking for the stuff they missed out last time

Nathan, once you've had that conversation with s9(2)(a) can you let me know how it went.

Thanks,  
Ben

---

**From:** Nathan Murrell  
**Sent:** Monday, 27 May 2019 1:59 PM  
**To:** Lynn Williams <[Lynn.Williams@nzta.govt.nz](mailto:Lynn.Williams@nzta.govt.nz)>; Ben Gamboni <[Ben.Gamboni@nzta.govt.nz](mailto:Ben.Gamboni@nzta.govt.nz)>; Neil McAlpine <[Neil.McAlpine@nzta.govt.nz](mailto:Neil.McAlpine@nzta.govt.nz)>; Robert Montgomery <[Robert.Montgomery@nzta.govt.nz](mailto:Robert.Montgomery@nzta.govt.nz)>  
**Subject:** RE: PHL - new s198 draft

The drug testing is included in 2), but perhaps I should have it as a separate point?  
Employment contracts are covered in 3), which I have amended slightly to say "all currently employed by PHL"

---

**From:** Lynn Williams  
**Sent:** Monday, 27 May 2019 1:51 PM  
**To:** Nathan Murrell <[Nathan.Murrell@nzta.govt.nz](mailto:Nathan.Murrell@nzta.govt.nz)>; Ben Gamboni <[Ben.Gamboni@nzta.govt.nz](mailto:Ben.Gamboni@nzta.govt.nz)>; Neil McAlpine <[Neil.McAlpine@nzta.govt.nz](mailto:Neil.McAlpine@nzta.govt.nz)>; Robert Montgomery <[Robert.Montgomery@nzta.govt.nz](mailto:Robert.Montgomery@nzta.govt.nz)>  
**Subject:** RE: PHL - new s198 draft

Hi Nathan

I've had a quick look and think that you should also include at least 6 x employment contracts (you name the drivers you want or let them send random ones) as well as all drug testing that has been completed on individual drivers during the month of ???

Regards



Lynn

---

**From:** Nathan Murrell

**Sent:** Monday, 27 May 2019 1:44 PM

**To:** Ben Gamboni <[Ben.Gamboni@nzta.govt.nz](mailto:Ben.Gamboni@nzta.govt.nz)>; Neil McAlpine <[Neil.McAlpine@nzta.govt.nz](mailto:Neil.McAlpine@nzta.govt.nz)>; Lynn Williams <[Lynn.Williams@nzta.govt.nz](mailto:Lynn.Williams@nzta.govt.nz)>; Robert Montgomery <[Robert.Montgomery@nzta.govt.nz](mailto:Robert.Montgomery@nzta.govt.nz)>

**Subject:** PHL - new s198 draft

Hi everyone,

I have just completed a draft s198 request for PHL and would be very grateful for your input. The points all address the areas that they have either partially or fully failed to comply with for the previous request. Some of the wording may need to be changed to get the right message across.

Ben – I will also draft a letter up along the lines of the email that we sent to s9(2)(b)(ii)

Regards,  
Nathan

Nathan Murrell / Commercial Transport Officer  
Road Compliance, Lower North Island  
DDI s9(2)(a)  
E [nathan.murrell@nzta.govt.nz](mailto:nathan.murrell@nzta.govt.nz) / [www.nzta.govt.nz](http://www.nzta.govt.nz)  
Chews Lane Office / 50 Victoria Street  
Private Bag 6995, Wellington 6141, New Zealand

cid:image001.png@01D4BC73.BC0BD520



Released under the Official Information Act 1982

**From:** [Nathan Murrell](#)  
**To:** s9(2)(a)  
**Subject:** Roadside Pass Rates  
**Date:** Tuesday, 1 October 2019 11:18:00 AM  
**Attachments:** [50108 Pacific Haulage Limited - RID Aug-Sept 2019.pdf](#)  
[50108 Pacific Haulage Limited - RID 2 years to end Sept 2019.pdf](#)  
[image002.jpg](#)  
[image004.jpg](#)  
[image006.jpg](#)  
[image008.jpg](#)

---

Hi s9(2)(a),

I hope things are going well with your new systems now that the first month is done and dusted. No doubt there would have been some teething issues, but it will be good to see the results going forward.

I have just run the RID reports for the last two year period, and also just for August and September out of interest. (both attached)  
The two year report has improved to 65% pass rate thanks to a lot of good results in August, so this should keep tracking upwards as the older results drop off.

The report just for the Aug/Sept period is showing a 75% pass rate, which reinforces the upward trend in pass rates that we are seeing.

I would have hoped for a slightly higher pass rate for these two months, but at least we are making progress.

Improvements should be easy to make looking at the failed inspections:

- lighting fault on CVIR 170358 should have been picked up before being driven off by way of walkaround.
- fluid leak on CVIR 158599 also to be picked up with walkaround check
- brake faults on CVIR 162770 – is this the one we discussed that had been serviced the day before (PHL22)?

Hopefully the new integrated daily checks and reporting system should see these types of faults disappearing – it will be interesting to see.

Did you still want me to have a look into the brake fault on CVIR 162770 for PHL22 that we discussed on the phone last time?

If you do then please let me know and forward any information to me that you have regarding it – a copy of the service sheet and maybe any photos following inspection.

I'll try catch up with you by phone shortly.

Regards,  
Nathan

Nathan Murrell / Commercial Transport Officer  
Road Compliance, Lower North Island

DD s9(2)(a)  
E [nathan.murrell@nzta.govt.nz](mailto:nathan.murrell@nzta.govt.nz) / w [nzta.govt.nz](http://nzta.govt.nz)  
Waka Kotahi NZ Transport Agency  
**Chews Lane Office** / 50 Victoria Street  
Private Bag 6995, Wellington 6141, New Zealand

**From:** [Elaine Smith](#)  
**To:** [Nathan Murrell](#)  
**Subject:** RE: Full Fit & Proper checks  
**Date:** Thursday, 14 March 2019 1:51:59 PM  
**Attachments:** [image006.jpg](#)  
[image007.jpg](#)  
[image008.jpg](#)  
[image009.jpg](#)  
[image010.jpg](#)  
[image011.png](#)  
[image012.jpg](#)  
[image013.jpg](#)  
[image014.jpg](#)  
[image015.jpg](#)  
[image016.jpg](#)  
[image017.jpg](#)  
[image018.jpg](#)  
[image019.jpg](#)  
[image020.jpg](#)

---

No problems

**Elaine Smith**  
**Regulatory Capability Programme Co-ordinator/**  
**Regional Administrator Road Compliance and Provider Compliance, Lower North Island**  
Regulatory Group

DDI +s9(2)(a) / M s9(2)(a)  
E [elaine.smith@nzta.govt.nz](mailto:elaine.smith@nzta.govt.nz) / w [nzta.govt.nz](http://nzta.govt.nz)

**Chews Lane Office** / Victoria Arcade, 50 Victoria Street,  
Private Bag 6995, Wellington 6141, New Zealand

cid:image001.png@01CF33D1.FBAE4F80



---

**From:** Nathan Murrell  
**Sent:** Thursday, 14 March 2019 1:50 PM  
**To:** Elaine Smith <[Elaine.Smith@nzta.govt.nz](mailto:Elaine.Smith@nzta.govt.nz)>  
**Subject:** RE: Full Fit & Proper checks

Amended....sorry!

---

**From:** Elaine Smith  
**Sent:** Thursday, 14 March 2019 1:45 PM  
**To:** Nathan Murrell <[Nathan.Murrell@nzta.govt.nz](mailto:Nathan.Murrell@nzta.govt.nz)>  
**Subject:** FW: Full Fit & Proper checks

Hi Nathan

DoB please for all.

Thanks

**Elaine Smith**  
Regulatory Capability Programme Co-ordinator/  
Regional Administrator Road Compliance and Provider Compliance, Lower North Island  
Regulatory Group

DDI s9(2)(a) / M s9(2)(a)

E [elaine.smith@nzta.govt.nz](mailto:elaine.smith@nzta.govt.nz) / w [nzta.govt.nz](http://nzta.govt.nz)

Chews Lane Office / Victoria Arcade, 50 Victoria Street,  
Private Bag 6995, Wellington 6141, New Zealand



---

**From:** Nathan Murrell  
**Sent:** Thursday, 14 March 2019 1:14 PM  
**To:** Elaine Smith <[Elaine.Smith@nzta.govt.nz](mailto:Elaine.Smith@nzta.govt.nz)>  
**Cc:** Lynn Williams <[Lynn.Williams@nzta.govt.nz](mailto:Lynn.Williams@nzta.govt.nz)>  
**Subject:** Full Fit & Proper checks

Good afternoon Elaine,

Could I please have F&P checks done on the following drivers who are employees of "Pacific Haulage Limited" TSL s18(c)(i)

FIRST NAMES	SURNAME	DOB	DLICNO
-------------	---------	-----	--------

ADDRESS
---------

s9(2)(a)

Released under the Official Information Act 1982

s9(2)(a)

Regards,  
Nathan

Nathan Murrell / Commercial Transport Officer  
Road Compliance, Lower North Island  
DDI s9(2)(a) / M s9(2)(a)  
E [nathan.murrell@nzta.govt.nz](mailto:nathan.murrell@nzta.govt.nz) / w [nzta.govt.nz](http://nzta.govt.nz)  
Chews Lane Office / 50 Victoria Street  
Private Bag 6995, Wellington 6141, New Zealand

cid:image001.png@01D4BC73.BC0BD520



Released under the Official Information Act 1982

**From:** [Nathan Murrell](#)  
**To:** s9(2)(a)  
**Subject:** RE: Pacific Haulage - Collection of Records 27 March 2019  
**Date:** Monday, 10 June 2019 1:32:00 PM  
**Attachments:** [50108 Pacific Haulage Limited First Failed COF 3 2019 03 01.pdf](#)  
[50108 Pacific Haulage Limited First Failed COF 1 2019 03 01.pdf](#)  
[50108 Pacific Haulage Limited RID 7 2019 03 01.pdf](#)  
[image001.jpg](#)  
[image002.png](#)  
[image003.jpg](#)  
[image004.jpg](#)  
[image005.jpg](#)  
[image006.jpg](#)

---

Hi s9(2)(a)

Please find attached two reports in regards to COF pass rates.  
The third report relates to roadside inspections, and is a summary of the results from all roadside inspections from 28.02.17 to 27.02.19.

If you want details around the actual faults at the time of inspection, these will be contained in the CVIR reports that are emailed to s9(2)(a).  
Notes are compiled by the officer at the time of stop, and should be found on the reverse side of the CVIR. Notes are not always completed.  
The "Categorisation of Defects" directs the action taken once a fault is located.

Regards,  
Nathan

---

**From:** s9(2)(a)  
**Sent:** Monday, 10 June 2019 1:16 PM  
**To:** Nathan Murrell <Nathan.Murrell@nzta.govt.nz>  
**Subject:** RE: Pacific Haulage - Collection of Records 27 March 2019

Hi Nathan,  
I would appreciate if you could provide the RID and COF data that you based the audit on, as per our conversation 27<sup>th</sup> March when you collected the records.  
You claimed that we had somewhere around 54% fail rate for brakes, and a lesser number for lights, so I would like to understand how you arrived at those figures.  
For Pacific Haulage to improve their maintenance practices, we need the detail around the faults.  
As you stated, when you undertook roadside inspections, you would write the detail around the fault, rather than rely on the code available, and we need to understand the vehicle safety impact of the faults recorded.

Regards  
s9(2)(a)

s9(2)(a)

cid:image003.jpg@01CF58AA.D03061B0

49-55 Biak Street, Rotorua 3015

p s9(2)(a)

M: s9(2)(a)

s9(2)(a)

---

**From:** Nathan Murrell [<mailto:Nathan.Murrell@nzta.govt.nz>]

**Sent:** Wednesday, 27 March 2019 4:13 p.m.

**To:** s9(2)(a)

**Subject:** Re: Pacific Haulage - Collection of Records 27 March 2019

Hi s9(2)(a)

When doing audits we always run RID and COF reports for a 2 year period. This matched up with the ORS reports which were for a 2 year period, which is obviously all on hold at the moment.

I don't have the reports with me so can't give the exact date I ran them, but they were around the last week of February or first week of March.

Thanks for your time today, was good to meet the team.

Regards

Nathan

Nathan Murrell

Commercial Transport Officer

New Zealand Transport Agency

T: s9(2)(a)

E: [nathan.murrell@nzta.govt.nz](mailto:nathan.murrell@nzta.govt.nz)

---

**From:** s9(2)(a)

**Sent:** Wednesday, March 27, 2019 16:07

**To:** Nathan Murrell

**Subject:** RE: Pacific Haulage - Collection of Records 27 March 2019

Hi Nathan,

Further to our meeting this morning, could you advise the period that you have gathered the RID data over.

s9(2)(a) went back over the last 6 months, we had 1 brake fault noted in 45 inspections.

Regards

s9(2)(a)

s9(2)(a)

cid:image003.jpg@01CF58AA.D03061B0

s9(2)(a)

P: s9(2)(a)

M: s9(2)(a)

s9(2)(a)

---

**From:** Nathan Murrell [<mailto:Nathan.Murrell@nzta.govt.nz>]  
**Sent:** Friday, 15 March 2019 7:42 a.m.  
**To:** s9(2)(a)  
**Cc:** Ben Gamboni; Lynn Williams  
**Subject:** Pacific Haulage - Collection of Records 27 March 2019

Good morning s9(2)(a),

Apologies for the lack of introduction on my part.

I have recently joined the Wellington compliance team in early February following an 11 year career in NZ Police, most recently with 3.5 years in CVST.

I will be flying into Gisborne with our manager Ben Gamboni just after 10.00am on Wednesday the 27<sup>th</sup> of March 2019.

Along with Lynn Williams we anticipate that we will be at the Pacific Haulage office at approximately 11.00am to collect the records as requested.

It would be fantastic if you were able to be present to allow both Ben and myself to make further introductions in person.

If you have any questions please don't hesitate to contact me on the numbers below, otherwise I look forward to meeting with you soon.

Regards,  
Nathan

Nathan Murrell / Commercial Transport Officer  
Road Compliance, Lower North Island

DDI: s9(2)(a) / M: s9(2)(a)

E: [nathan.murrell@nzta.govt.nz](mailto:nathan.murrell@nzta.govt.nz) / w: [nzta.govt.nz](http://nzta.govt.nz)

Chews Lane Office / 50 Victoria Street  
Private Bag 6995, Wellington 6141, New Zealand

cid:image001.png@01D4BC73.BC0BD520



**From:** [Nathan Murrell](#)  
**To:** s9(2)(a)  
**Subject:** Audit Outcome  
**Date:** Friday, 9 August 2019 1:08:00 PM  
**Attachments:** [50108 Pacific Haulage Limited - SCANNED Audit Outcome.pdf](#)  
[image001.png](#)  
[image002.jpg](#)  
[image003.jpg](#)  
[image004.jpg](#)  
[image005.jpg](#)

---

Good afternoon s9(2)(a),

Please find attached an "Audit Outcome" letter in regards to the audit currently being undertaken of Pacific Haulage Limited by the Agency.

We are pleased to say that we have concluded the audit at this stage. We will however be monitoring reports on a 3-monthly basis to ensure progress continues to be made.

Both Wendy & I were very impressed with the work that s9(2)(a) had been doing, and it has been great to see that this is already showing results.

We look forward to working with you and seeing how those improvements continue to be made, as we are all aware it will take time for the results to become evident.

s9(2)(a) – please keep in touch and let us know if there is anything we can do to assist. I'm only too happy to provide reports and supply any information you require, or assist with any enquiries as we have already done.

Have a great weekend.

Regards,

Nathan

Nathan Murrell / Commercial Transport Officer  
Road Compliance, Lower North Island  
DDI s9(2)(a) / M s9(2)(a)  
E [nathan.murrell@nzta.govt.nz](mailto:nathan.murrell@nzta.govt.nz) / w [nzta.govt.nz](http://nzta.govt.nz)  
Chews Lane Office / 50 Victoria Street  
Private Bag 6995, Wellington 6141, New Zealand

cid:image001.png@01D4BC73.BC0BD520



Released under the Official Information Act 1982

**From:** [Nathan Murrell](#)  
**To:** [Elaine Smith \(Elaine.Smith@nzta.govt.nz\)](mailto:Elaine.Smith@nzta.govt.nz)  
**Cc:** [Lynn Williams](#)  
**Subject:** Full Fit & Proper checks  
**Date:** Thursday, 14 March 2019 1:14:00 PM  
**Attachments:** [image001.png](#)  
[image002.jpg](#)  
[image003.jpg](#)  
[image004.jpg](#)  
[image005.jpg](#)

---

Good afternoon Elaine,

Could I please have F&P checks done on the following drivers who are employees of "Pacific Haulage Limited" TSL s18(c)(i)

FIRST NAMES	SURNAME	DLICNO	ADDRESS
s9(2)(a)			

Regards,  
Nathan

Nathan Murrell / Commercial Transport Officer  
Road Compliance, Lower North Island  
DDI s9(2)(a) / M s9(2)(a)  
E [nathan.murrell@nzta.govt.nz](mailto:nathan.murrell@nzta.govt.nz) / w [nzta.govt.nz](http://nzta.govt.nz)  
Chews Lane Office / 50 Victoria Street  
Private Bag 6995, Wellington 6141, New Zealand

cid:image001.png@01D4BC73.BC0BD520

**From:** [Nathan Murrell](#)  
**To:** s9(2)(a)  
**Subject:** Further s198 request  
**Date:** Friday, 7 June 2019 4:33:00 PM  
**Attachments:** [image001.png](#)  
[image002.jpg](#)  
[image003.jpg](#)  
[image004.jpg](#)  
[image005.jpg](#)  
[50108 Pacific Haulage Limited - s198 Request 20190607.pdf](#)

---

Good afternoon s9(2)(a)

Please find attached a new s198 request for information.

- Section 1 specifically requests employment agreements for the 6 listed drivers only.
- Section 2-4 requests overspeed reports and documentation around the management of speed related offending, to ensure operators are addressing high risk behaviours.
- This is currently a focus of the agency around managing high risk driving behaviours and is a part of all audits.  
The report under Section 2 is a simple overview and should be no more than 1-2 pages.
- Section 5 again seeks evidence to ensure that where drivers are committing offences on the road, that PHL are addressing those issues to manage risk.  
No information was provided on the previous request. Where this is not performed, I would be grateful for written confirmation.
- Section 6 requests evidence of drug testing documentation. Despite your assurances, there was no documentation previously submitted, including s9(2)(a) reported incident.
- Section 7 gives PHL another opportunity to provide evidence of driver daily vehicle inspections by way of physical daily checks sheets. Where this is not performed, I would be grateful for written confirmation.
- Section 8 seeks evidence that there is a clearly defined maintenance system in place, and that all maintenance is recorded. The previously supplied invoices from TPW are NOT evidence of a maintenance system.

I look forward to receiving your submissions.

Regards,

Nathan

**Nathan Murrell / Commercial Transport Officer**  
Road Compliance, Lower North Island  
DDI s9(2)(a) / M +s9(2)(a)  
E [nathan.murrell@nzta.govt.nz](mailto:nathan.murrell@nzta.govt.nz) / w [nzta.govt.nz](http://nzta.govt.nz)  
Chews Lane Office / 50 Victoria Street  
Private Bag 6995, Wellington 6141, New Zealand

**From:** [Robert Montgomery](#)  
**To:** [Nathan Murrell](#); [Ben Gamboni](#)  
**Subject:** FW: Pacific Haulage Ltd  
**Date:** Tuesday, 21 May 2019 10:53:54 AM  
**Attachments:** [50108 Pacific Haulage Limited - Final Report.pdf](#)  
[image001.png](#)  
[image002.jpg](#)  
[image003.jpg](#)  
[image004.jpg](#)  
[image005.jpg](#)

---

An excellent report thanks Nathan.

I will take to triage this week to discuss. s9(2)(h)

Thanks

**Rob Montgomery** / Commercial Transport Advisor  
Lower North Island  
Regulatory Group

DDI [s9\(2\)\(a\)](#) / M [s9\(2\)\(a\)](#)  
E [robert.montgomery@nzta.govt.nz](mailto:robert.montgomery@nzta.govt.nz) / W [nzta.govt.nz](http://nzta.govt.nz)

Palmerston North Office / Level 3, 43 Ashley Street,  
Private Bag 11777, Palmerston North 4440, New Zealand

---

**From:** Nathan Murrell  
**Sent:** Monday, 20 May 2019 3:27 PM  
**To:** Robert Montgomery <[Robert.Montgomery@nzta.govt.nz](mailto:Robert.Montgomery@nzta.govt.nz)>  
**Subject:** Pacific Haulage Ltd

Hi Rob,

Please find attached final report for PHL.

Cheers  
Nathan

**Nathan Murrell** / Commercial Transport Officer  
Road Compliance, Lower North Island  
DDI [s9\(2\)\(a\)](#) / M [s9\(2\)\(a\)](#)  
E [nathan.murrell@nzta.govt.nz](mailto:nathan.murrell@nzta.govt.nz) / W [nzta.govt.nz](http://nzta.govt.nz)  
Chews Lane Office / 50 Victoria Street  
Private Bag 6995, Wellington 6141, New Zealand

cid:image001.png@01D4BC73.BC0BD520



Released under the Official Information Act 1982

**From:** [Nathan Murrell](#)  
**To:** [Robert Montgomery](#)  
**Subject:** Pacific Haulage Ltd  
**Date:** Monday, 20 May 2019 3:26:00 PM  
**Attachments:** [50108 Pacific Haulage Limited - Final Report.pdf](#)  
[image001.png](#)  
[image002.jpg](#)  
[image003.jpg](#)  
[image004.jpg](#)  
[image005.jpg](#)

---

Hi Rob,

Please find attached final report for PHL.

Cheers  
Nathan

**Nathan Murrell / Commercial Transport Officer**  
Road Compliance, Lower North Island  
DDI [s9\(2\)\(a\)](#) / M [s9\(2\)\(a\)](#)  
E [nathan.murrell@nzta.govt.nz](mailto:nathan.murrell@nzta.govt.nz) / W [nzta.govt.nz](http://nzta.govt.nz)  
Chews Lane Office / 50 Victoria Street  
Private Bag 6995, Wellington 6141, New Zealand

cid:image001.png@01D4BC73.BC0BD520



Released under the Official Information Act 1982

**From:** [Nathan Murrell](#)  
**To:** [Ben Gamboni](#); [Neil McAlpine](#); [Lynn Williams](#); [Robert Montgomery](#)  
**Subject:** PHL - new s198 draft  
**Date:** Monday, 27 May 2019 1:44:00 PM  
**Attachments:** [DRAFT 50108 Pacific Haulage Limited s198 Request 20190527.docx](#)  
[image001.png](#)  
[image002.jpg](#)  
[image003.jpg](#)  
[image004.jpg](#)  
[image005.jpg](#)

---

Hi everyone,

I have just completed a draft s198 request for PHL and would be very grateful for your input. The points all address the areas that they have either partially or fully failed to comply with for the previous request.

Some of the wording may need to be changed to get the right message across.

Ben – I will also draft a letter up along the lines of the email that we sent to s9(2)(b)(i).

Regards,  
Nathan

Nathan Murrell / Commercial Transport Officer  
Road Compliance, Lower North Island  
DDI +s9(2)(a) / M s9(2)(a)  
E [nathan.murrell@nzta.govt.nz](mailto:nathan.murrell@nzta.govt.nz) / w [nzta.govt.nz](http://nzta.govt.nz)  
Chews Lane Office / 50 Victoria Street  
Private Bag 6995, Wellington 6141, New Zealand

cid:image001.png@01D4BC73.BC0BD520

■

---

■

■

■

■

Released under the Official Information Act 1982

**From:** [Nathan Murrell](#)  
**To:** [Lynn Williams](#)  
**Subject:** PHL  
**Date:** Friday, 7 June 2019 12:06:00 PM  
**Attachments:** [DRAFT 50108 Pacific Haulage Limited s198 Request 20190527.docx](#)  
[image001.png](#)  
[image002.jpg](#)  
[image003.jpg](#)  
[image004.jpg](#)  
[image005.jpg](#)

---

Hi Lynn,

Here is the copy of the new s198 that I have drafted.

I sent it to Ben earlier in the week but haven't had feedback from him yet, and really need to get it off to **s9(2)(a)** today.

Could you please let me know what you think (if you are working and available). I'm here until around 5pm having started later than normal today.

Cheers

Nathan

**Nathan Murrell / Commercial Transport Officer**

Road Compliance, Lower North Island

DDI +**s9(2)(a)** / M +**s9(2)(a)**

E [nathan.murrell@nzta.govt.nz](mailto:nathan.murrell@nzta.govt.nz) / w [nzta.govt.nz](http://nzta.govt.nz)

Chews Lane Office / 50 Victoria Street

Private Bag 6995, Wellington 6141, New Zealand

cid:image001.png@01D4BC73.BC0BD520



Released under the Official Information Act 1982

**From:** [Nathan Murrell](#)  
**To:** s9(2)(a)  
**Subject:** Audit Outcome  
**Date:** Friday, 9 August 2019 1:08:00 PM  
**Attachments:** [50108 Pacific Haulage Limited - SCANNED Audit Outcome.pdf](#)  
[image001.png](#)  
[image002.jpg](#)  
[image003.jpg](#)  
[image004.jpg](#)  
[image005.jpg](#)

---

Good afternoon s9(2)(a),

Please find attached an "Audit Outcome" letter in regards to the audit currently being undertaken of Pacific Haulage Limited by the Agency.

We are pleased to say that we have concluded the audit at this stage. We will however be monitoring reports on a 3-monthly basis to ensure progress continues to be made.

Both Wendy & I were very impressed with the work that s9(2)(a) had been doing, and it has been great to see that this is already showing results.

We look forward to working with you and seeing how those improvements continue to be made, as we are all aware it will take time for the results to become evident.

s9(2)(a) – please keep in touch and let us know if there is anything we can do to assist. I'm only too happy to provide reports and supply any information you require, or assist with any enquiries as we have already done.

Have a great weekend.

Regards,

Nathan

**Nathan Murrell / Commercial Transport Officer**  
Road Compliance, Lower North Island  
DDI s9(2)(a) / M s9(2)(a)  
E [nathan.murrell@nzta.govt.nz](mailto:nathan.murrell@nzta.govt.nz) / w [nzta.govt.nz](http://nzta.govt.nz)  
Chews Lane Office / 50 Victoria Street  
Private Bag 6995, Wellington 6141, New Zealand

cid:image001.png@01D4BC73.BC0BD520



Released under the Official Information Act 1982



09 August 2019

s9(2)(a)

Pacific Haulage Limited  
107 Aerodrome Road  
Gisborne 4071

Dear s9(2)(a)

### Audit Outcome

I would like to thank you and s9(2)(a) for your time on Thursday the 25<sup>th</sup> of July 2019 at your office in Gisborne.

Both Wendy & I felt that the meeting was hugely beneficial to both parties and were very impressed with the proactive approach that s9(2)(a) has taken with the company since he has come onboard. In many instances the concerns we had have already been addressed, with programs and processes put in place.

Through the conversations we had with s9(2)(a) he was able to provide the answers we were after, but at the same time was willing to take on some of the advice we also provided around managing driver offending and improving roadside pass rates. This cooperative approach is the best way forward, and I have been pleased to see this continue with s9(2)(a) contacting me directly on a number of occasions since our meeting.

The outcome of the roadside operations was also pleasing to see with a reduction in roadside faults located. There was also a noticeable difference in the quality of the logbooks produced. At the beginning of the audit your RID pass rate was 54%. Prior to our meeting this had increased to 63% and following the two days of roadside inspections it has continued to rise.

Therefore, we are pleased to advise that we have concluded our audit. We will however undertake a 3-monthly review over the next 12 months to monitor the progress of Pacific Haulage and ensure that improvements are continued to be made.

We look forward to maintaining contact with both yourself and s9(2)(a) and are more than happy to offer our services at any stage if we are able to be of any further assistance.

Yours sincerely,

s9(2)(a)

**Nathan Murrell**  
Commercial Transport Officer

Released under the Official Information Act 1982

**From:** [Elaine Smith](#)  
**To:** [Nathan Murrell](#)  
**Subject:** FW: MoJ please for company and persons below  
**Date:** Tuesday, 5 March 2019 8:50:54 AM  
**Attachments:** [image001.png](#)  
[image012.jpg](#)  
[image013.jpg](#)  
[image014.jpg](#)  
[image015.jpg](#)  
[image016.jpg](#)  
s9(2)(a) [REDACTED]  
[Pacific Haulage Limited.pdf](#)  
[image007.jpg](#)  
[image008.jpg](#)  
[image009.jpg](#)  
[image010.jpg](#)  
[image011.jpg](#)

Hi Nathan

Please find attached MoJ FYI&A.

regards

**Elaine Smith**  
Regulatory Capability Programme Co-ordinator/  
Regional Administrator Road Compliance and Provider Compliance, Lower North Island  
Regulatory Group

DD | s9(2)(a) [REDACTED] / M | s9(2)(a) [REDACTED]

E [elaine.smith@nzta.govt.nz](mailto:elaine.smith@nzta.govt.nz) / w [nzta.govt.nz](http://nzta.govt.nz)

Chews Lane Office / Victoria Arcade, 50 Victoria Street,  
Private Bag 6995, Wellington 6141, New Zealand

cid:image001.png@01CF33D1.FBAE4F80



**From:** CPUinforequest <CPUinforequest@justice.govt.nz>

**Sent:** Tuesday, 5 March 2019 8:49 AM

**To:** Elaine Smith <Elaine.Smith@nzta.govt.nz>

**Subject:** RE: MoJ please for company and persons below

Dear Elaine

Out of scope

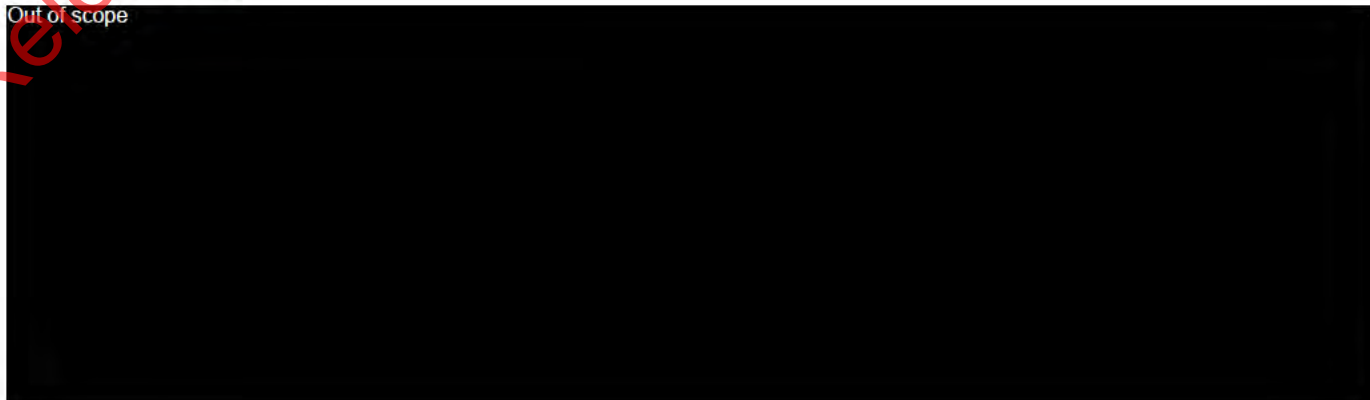

Released under the Official Information Act 1982

Out of scope

- Thank you for your recent correspondence requesting, under Section 30 of the Land Transport Act 1998, a summary of fines for Pacific Haulage Limited

In response to your request, I enclose a Fines Summary for Pacific Haulage Limited

I trust this information is helpful.

Yours Sincerely

s9(2)(a)

Central Registry | District Courts of New Zealand  
DX SX10042, Wellington  
0800 233 222 (Collections)  
0800 268 787 (Courts)  
[www.justice.govt.nz](http://www.justice.govt.nz)

---

**From:** Elaine Smith <[Elaine.Smith@nzta.govt.nz](mailto:Elaine.Smith@nzta.govt.nz)>

**Sent:** Monday, 4 March 2019 9:53 a.m.

**To:** CPUinforequest <[CPUinforequest@justice.govt.nz](mailto:CPUinforequest@justice.govt.nz)>

**Subject:** MoJ please for company and persons below

Good morning

**We are currently undertaking an investigation of persons and company listed below.**

**Part of the investigation is to determine the criteria specified in Section 30 of the Land Transport Act 1998 whether the below named persons/company are a fit and proper persons/company for any of the purposes of this Act.**

**I request that the Ministry of Justice provide a full fines summary for of the below mentioned persons/company.**

**This needs to include all cases that are imposed, in default, breached arrangements, under arrangement, under enforcement, satisfied, closed or under appeal/rehearing**

**This information is sought under the Official Information Act and can be released by your organisation pursuant to Principle 11 of the Privacy Act.**

- 1. Pacific Haulage Limited, 107 Aerodrome Road, Matawhero, Gisborne. TSL:**

s18(c)(i)

Out of scope

Out of scope

Regards

**Elaine Smith**

**Regulatory Capability Programme Co-ordinator/**

**Regional Administrator Road Compliance and Provider Compliance, Lower North Island**

Regulatory Group

DDI  / M 

E [elaine.smith@nzta.govt.nz](mailto:elaine.smith@nzta.govt.nz) / w [nzta.govt.nz](http://nzta.govt.nz)

**Chews Lane Office** / Victoria Arcade, 50 Victoria Street,  
Private Bag 6995, Wellington 6141, New Zealand

cid:image001.png@01CF33D1.FBAE4F80



Find the latest transport news, information, and advice on our website:

[www.nzta.govt.nz](http://www.nzta.govt.nz)

---

This email is only intended to be read by the named recipient. It may contain information which is confidential, proprietary or the subject of legal privilege. If you are not the intended recipient you must delete this email and may not use any information contained in it. Legal privilege is not waived because you have read this email.

---

**Confidentiality notice:**

This email may contain information that is confidential or legally privileged. If you have received it by mistake, please:

- (1) reply promptly to that effect, and remove this email and the reply from your system;
- (2) do not act on this email in any other way.

Thank you.

---

Released under the Official Information Act 1982

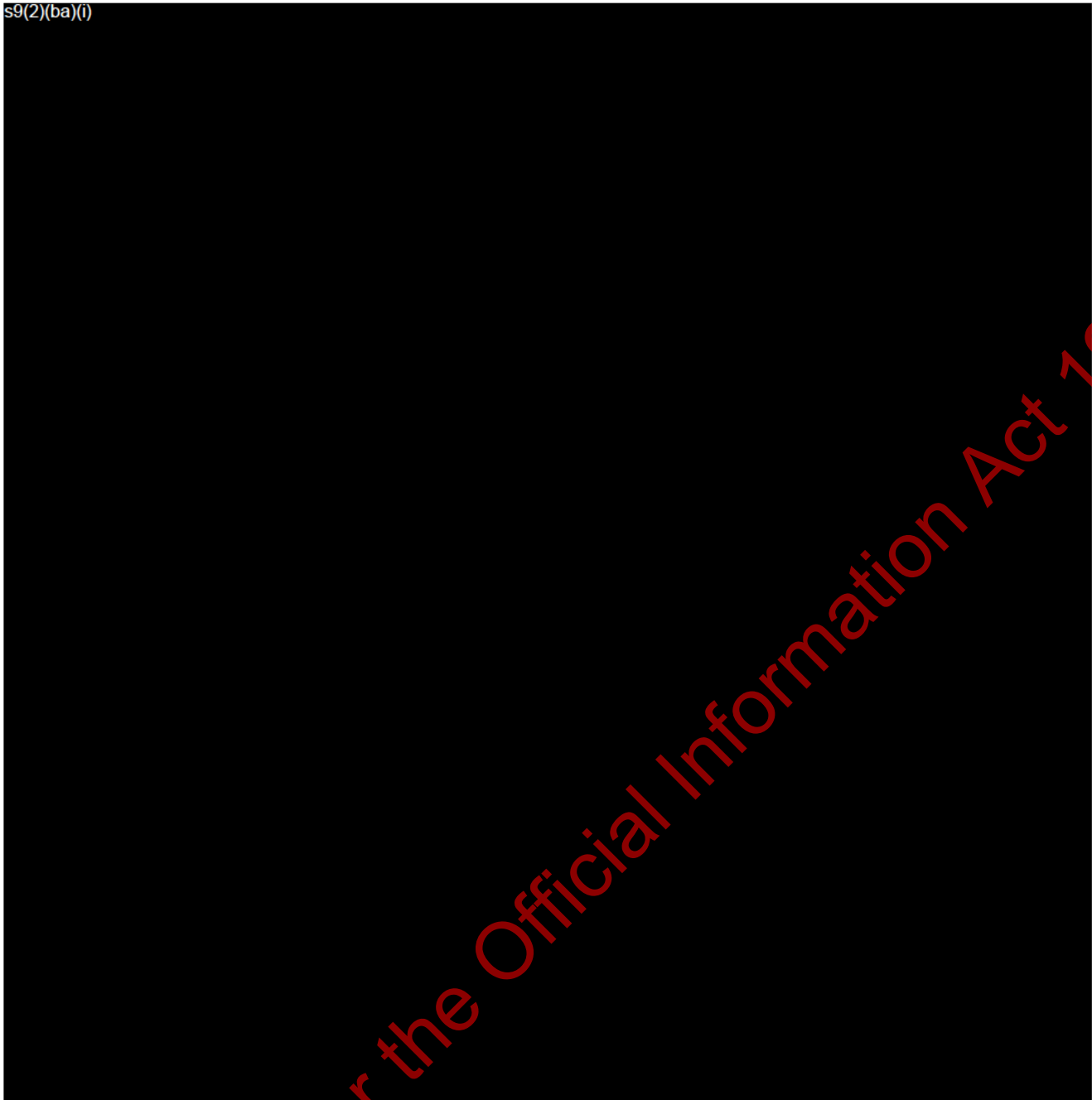

Released under the Official Information Act 1982



**From:** [Nathan Murrell](#)  
**To:** [Lynn Williams](#); [Robert Montgomery](#); [Ben Gamboni](#)  
**Subject:** FW: Query in regards to "Breach of Privacy" vs s198 Land Transport Act 1998 Requests for Records  
**Date:** Thursday, 4 July 2019 1:38:00 PM  
**Attachments:** [image001.png](#)  
[image002.jpg](#)  
[image003.jpg](#)  
[image004.jpg](#)  
[image005.jpg](#)

---

Hi everyone,

Here is the response that I got from the legal team in regards to Pacific Haulage Limited failing to supply drug testing records, citing "breach of driver privacy".

It appears as though we are justified in requesting the records in the interests of road safety i.e. these drivers are high risk and the company needs to show they are managing that risk appropriately.

I'd be interested in your thoughts and how we can move forward with PHL. Perhaps this could be a topic of conversation to cover with the whole team?

Regards,  
Nathan

---

**From:** Andrew Thompson  
**Sent:** Thursday, 4 July 2019 12:31 PM  
**To:** Nathan Murrell <[Nathan.Murrell@nzta.govt.nz](mailto:Nathan.Murrell@nzta.govt.nz)>  
**Cc:** Lynn Williams <[Lynn.Williams@nzta.govt.nz](mailto:Lynn.Williams@nzta.govt.nz)>  
**Subject:** RE: Query in regards to "Breach of Privacy" vs s198 Land Transport Act 1998 Requests for Records

Hi Nathan

Sorry for the delay and for the brevity of this reply.

s9(2)(h)



s9(2)(h)

Cheers

Andrew Thompson BA LLB (Hons)  
Principal Counsel, Regulatory  
Legal Services Team / Corporate Services  
DDI s9(2)(a) / M s9(2)(a)  
E [andrew.thompson@nzta.govt.nz](mailto:andrew.thompson@nzta.govt.nz) / w [nzta.govt.nz](http://nzta.govt.nz)  
Dunedin Office Level 2, AA Centre, 450 Moray Place,  
PO Box 5245, Moray Place, Dunedin 9058, New Zealand

---

**From:** Nathan Murrell  
**Sent:** Tuesday, 25 June 2019 8:27 AM  
**To:** Andrew Thompson <[Andrew.Thompson@nzta.govt.nz](mailto:Andrew.Thompson@nzta.govt.nz)>  
**Cc:** Lynn Williams <[Lynn.Williams@nzta.govt.nz](mailto:Lynn.Williams@nzta.govt.nz)>  
**Subject:** Query in regards to "Breach of Privacy" vs s198 Land Transport Act 1998 Requests for Records

Good morning Andrew,

I have been speaking to Lynn Williams who has been mentoring me with an audit for a Gisborne based log haulage company, Pacific Haulage Limited.

We issued an initial s198 request for records in February, parts of which asked for a list of all current drivers along with their drivers licence number, address and contact phone number. Also requested was records for drug testing of drivers, either pre-employment, as a result of an incident, or random testing.

In the submissions that followed, the drivers list included drivers licence numbers, but no record of address or contact phone number.  
No records for any drug testing were submitted.

When this was brought up with the company, s9(2)(a) responded saying that providing the drivers contact details would be a breach of privacy, therefore they were not provided.

Although he was adamant that drug testing records were submitted, we assured him they were not.

A subsequent s 198 request was sent in early June with one of the points focusing on the submission of ALL drug testing records for a 12 month period.  
We were presented with only one record relating to a traffic crash.

Correspondence again from s9(2)(a), stated that he was not of the belief that drug testing records should be requested as part of a compliance audit.

Although we have received the one record relating to the crash, he stated that "After taking advice, I am not able to provide the information requested, due to privacy issues."

What we would like assistance with is the issue of privacy vs our request for records. Does the s198 request and in particular "s113A Power to Inspect Records" give us sufficient power to request in particular the drug testing records, but also the drivers contact details? And does this override the companies want or need to protect privacy? The drug testing is an employment record, and the Agency assess the companies risk management practices as important to road safety.

We would be grateful if someone in the team would be able to provide an opinion, so that we can go back to the company with a response.

I have included excerpts from the relevant sections below.

Regards,  
Nathan

Nathan Murrell / Commercial Transport Officer  
Road Compliance, Lower North Island  
DDI +s9(2)(a) / M s9(2)(a)  
E [nathan.murrell@nzta.govt.nz](mailto:nathan.murrell@nzta.govt.nz) / w [nzta.govt.nz](http://nzta.govt.nz)  
Chews Lane Office / 50 Victoria Street  
Private Bag 6995, Wellington 6141, New Zealand

cid:image001.png@01D4BC73.BC0BD520

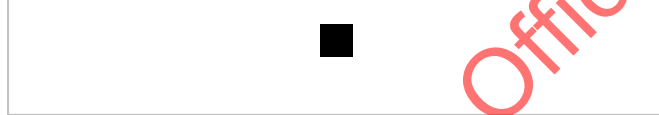

#### 198 Inspections and audits

- (1) The Agency may in writing require any person who holds a land transport document that authorises the provision of a service in the land transport system to undergo such inspections and audits as the Agency reasonably considers necessary in the interests of land transport safety (including inspections and audits of vehicles operated by such persons).
- (2) The Agency may carry out such inspections and audits as the Agency reasonably considers necessary in the interests of land transport safety.
- (3) For the purposes of any inspection or audit carried out in respect of any person under this section, the Agency may in writing require that person to provide such information as the Agency reasonably considers relevant to the inspection or audit.
- (4) A person to whom a requirement is made under this section must comply with that requirement.

#### 113A Power to inspect records

- (1) For the purpose of ascertaining whether this Act has been or is being complied with by any person to whom this Act applies, any enforcement officer in uniform or in possession of a warrant or other evidence of his or her authority as an enforcement officer may require that person to produce without delay for inspection all relevant books or records in that person's possession or over which that person has control, including (but not limited to) records kept under section 65 of the Road User Charges Act 2012, logbooks, records associated with logbooks, financial records relating to expenditure on fuel, invoices, vehicle maintenance records, depreciation records for vehicles, time and wage records, and waybills.



- (2) The enforcement officer may take extracts from or make copies of any books or records so produced.

Released under the Official Information Act 1982

**From:** [Robert Montgomery](#)  
**To:** [Nathan Murrell](#)  
**Subject:** FW: §9(2)(b)(i) [REDACTED] and Pacific Haulage Limited files  
**Date:** Wednesday, 6 March 2019 2:06:08 PM  
**Attachments:** [image001.png](#)  
[image002.jpg](#)  
[image003.jpg](#)  
[image004.jpg](#)  
[image005.jpg](#)  
[06-03-2019-13-42-43.pdf](#)

---

Thanks Nathan.

Not sure what is happening with the Pacific report. When I open it up from the infohub link it looks like the table with the faults in it is sitting on top of the Vehicle standards table. Very strange

Cheers

**Rob Montgomery**/Commercial Transport Advisor  
Lower North Island  
Regulatory Group

DDI [§9\(2\)\(a\)](#) [REDACTED] / M [§9\(2\)\(a\)](#) [REDACTED]  
E [robert.montgomery@nzta.govt.nz](mailto:robert.montgomery@nzta.govt.nz) / W [nzta.govt.nz](http://nzta.govt.nz)

Palmerston North Office / Level 3, 43 Ashley Street,  
Private Bag 11777, Palmerston North 4440, New Zealand

---

**From:** Nathan Murrell <[Nathan.Murrell@nzta.govt.nz](mailto:Nathan.Murrell@nzta.govt.nz)>  
**Sent:** Wednesday, 6 March 2019 1:47 PM  
**To:** Robert Montgomery <[Robert.Montgomery@nzta.govt.nz](mailto:Robert.Montgomery@nzta.govt.nz)>  
**Subject:** RE: Out of Scope [REDACTED] Ltd and Pacific Haulage Limited files

Hi Rob,

Out of Scope [REDACTED]

I opened the Pacific file without any problems at all. However I have scanned it in PDF and attached it for your review.

There are some boxes that apparently aren't applicable that have been greyed out....maybe that's what you were referring to?

Cheers  
Nathan

---

**From:** Robert Montgomery  
**Sent:** Wednesday, 6 March 2019 11:15 AM  
**To:** Nathan Murrell <[Nathan.Murrell@nzta.govt.nz](mailto:Nathan.Murrell@nzta.govt.nz)>  
**Subject:** RE: Out of Scope [REDACTED] and Pacific Haulage Limited files

Thanks Nathan.

I will bring these two operators up at the next triage meeting with Meredith Connell on 11 March.

Out of scope

In relation to Pacific haulage. Can you please just check the table for the vehicle COF & RID pass rates and faults as when I open the document the table appears to be corrupted and is hard to read. Once again we will need to explain this at the triage meeting so it needs to be clear where the issues are.

Any problems please give me a call.

Thanks

Rob

Rob Montgomery / Commercial Transport Advisor  
Lower North Island  
Regulatory Group

DDI: s9(2)(a) / M: s9(2)(a)  
E: [robert.montgomery@nzta.govt.nz](mailto:robert.montgomery@nzta.govt.nz) / W: [nzta.govt.nz](http://nzta.govt.nz)

Palmerston North Office / Level 3, 43 Ashley Street,  
Private Bag 11777, Palmerston North 4440, New Zealand

---

**From:** Nathan Murrell <[Nathan.Murrell@nzta.govt.nz](mailto:Nathan.Murrell@nzta.govt.nz)>

**Sent:** Tuesday, 5 March 2019 9:40 AM

**To:** Robert Montgomery <[Robert.Montgomery@nzta.govt.nz](mailto:Robert.Montgomery@nzta.govt.nz)>

**Subject:** RE: Out of Scope and Pacific Haulage Limited files

Hi Rob,

Finally getting the hang of Infohub! Links attached.

Link to internal NZTA document

Cheers  
Nathan

---

**From:** Robert Montgomery

**Sent:** Tuesday, 5 March 2019 9:30 AM

**To:** Nathan Murrell <[Nathan.Murrell@nzta.govt.nz](mailto:Nathan.Murrell@nzta.govt.nz)>

**Subject:** RE: Out of Scope and Pacific Haulage Limited files

Thanks Nathan.

If you have a report/recommendation memo for them could you please send it through to me. I

will need to take them to our next triage session with Meredith Connell and get agreement on next steps

Cheers

Rob

Rob Montgomery / Commercial Transport Advisor  
Lower North Island  
Regulatory Group

DDI [s9\(2\)\(a\)](#) / M [s9\(2\)\(a\)](#)  
E [robert.montgomery@nzta.govt.nz](mailto:robert.montgomery@nzta.govt.nz) / W [nzta.govt.nz](http://nzta.govt.nz)

Palmerston North Office / Level 3, 43 Ashley Street,  
Private Bag 11777, Palmerston North 4440, New Zealand

---

**From:** Nathan Murrell <[Nathan.Murrell@nzta.govt.nz](mailto:Nathan.Murrell@nzta.govt.nz)>

**Sent:** Monday, 4 March 2019 9:47 AM

**To:** Robert Montgomery <[Robert.Montgomery@nzta.govt.nz](mailto:Robert.Montgomery@nzta.govt.nz)>

**Subject:** [Out of Scope](#) Ltd and Pacific Haulage Limited files

Hi Rob,

It looks like I've finally completed these two files!

It was a bit of battle last week trying to steer away from the demands with [Out of Scope](#).

What is the next step? Do you they go to you for review? Or do you review the docs through Infohub and I retain the hard copy?

Cheers

Nathan

Nathan Murrell / Commercial Transport Officer  
Road Compliance, Lower North Island

DDI [s9\(2\)\(a\)](#) / M [s9\(2\)\(a\)](#)  
E [nathan.murrell@nzta.govt.nz](mailto:nathan.murrell@nzta.govt.nz) / W [nzta.govt.nz](http://nzta.govt.nz)

Chews Lane Office / 50 Victoria Street  
Private Bag 6995, Wellington 6141, New Zealand

cid:image001.png@01D4BC73.BC0BD520

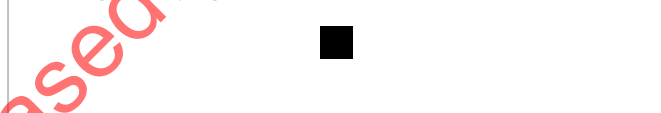

Released Under the Official Information Act 1982

**From:** [Nathan Murrell](#)  
**To:** s9(2)(a)  
**Subject:** Offence report for PHL vehicles  
**Date:** Monday, 29 July 2019 1:46:00 PM  
**Attachments:** [TOH Company.xlsx](#)  
[image001.png](#)  
[image002.jpg](#)  
[image003.jpg](#)  
[image004.jpg](#)  
[image005.jpg](#)

---

Hi s9(2)(a),

Please find attached the Traffic Offence History that I ran, for PHL vehicles where infringements were issued to and paid by the company.

The blue lines are inside the two year audit period, and the green have occurred since.

The yellow ones highlighted are the ones that probably apply in this situation we've discussed.

But the whole thing may give you an idea of some areas to work on also.

Asking around about TORO, the main info you would receive is around drivers demerits, with warnings issued when they are at 50 demerits, and again at 100 demerits where they become eligible for a 3 month suspension.

You are also advised where they are disqualified or suspended for other matters, ie appear in court for drink driving, Class 2-5 revocation etc, or where a medical revocation has taken place.

Regards,

Nathan

**Nathan Murrell / Commercial Transport Officer**  
Road Compliance, Lower North Island

DDI +s9(2)(a) / M +s9(2)(a)  
E [nathan.murrell@nzta.govt.nz](mailto:nathan.murrell@nzta.govt.nz) / w [nzta.govt.nz](http://nzta.govt.nz)  
Chews Lane Office / 50 Victoria Street  
Private Bag 6995, Wellington 6141, New Zealand

cid:image001.png@01D4BC73.BC0BD520



Released under the Official Information Act 1982





**From:** [Anna Reed](#)  
**To:** [Nathan Murrell](#)  
**Cc:** [Robert Montgomery](#)  
**Subject:** Pacific Haulage Limited - Triage Outcome  
**Date:** Thursday, 8 August 2019 1:23:49 PM  
**Attachments:** [image001.png](#)  
[image002.jpg](#)  
[image003.jpg](#)  
[image004.jpg](#)  
[image005.jpg](#)

---

Hello Nathan,

We discussed PHL at triage today.

As per your recommendations, please proceed with an audit outcome letter to PHL and continue to check in at 3 month intervals for the next 12 months.

Thanks  
Anna

Anna Reed / Commercial Transport Advisor  
Road Compliance, Lower North Island  
DDI [s9\(2\)\(a\)](#) / M [s9\(2\)\(a\)](#)  
E [anna.reed@nzta.govt.nz](mailto:anna.reed@nzta.govt.nz) / w [nzta.govt.nz](http://nzta.govt.nz)  
Chews Lane Office / 50 Victoria Street  
Private Bag 6995, Wellington 6141, New Zealand

cid:image001.png@01D4BC73.BC0BD520

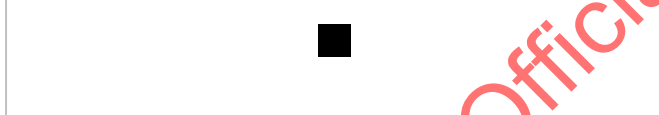

Released under the Official Information Act 1982



**From:** [Nathan Murrell](#)  
**To:** [Robert Montgomery](#)  
**Subject:** Pacific Haulage Limited  
**Date:** Monday, 27 May 2019 1:32:00 PM  
**Attachments:** [image001.png](#)  
[image002.jpg](#)  
[image003.jpg](#)  
[image004.jpg](#)  
[image005.jpg](#)

---

Hi Rob,

We discussed the audit for PHL at our Monday morning meeting.

At this stage it looks like the course of action we will be taking is going back to s9(2)(a) at PHL with a letter advising that they have failed to meet the obligations of the initial s198 request.

This will be accompanied by a second s198 request, with slightly more targeted wording to address the areas that they have failed to fulfil with the original request.

Once complete we will address how best to bring this up with the company.

s6(c)



Thanks  
Nathna

Nathan Murrell / Commercial Transport Officer  
Road Compliance, Lower North Island  
DDI +s9(2)(a) / M s9(2)(a)  
E [nathan.murrell@nzta.govt.nz](mailto:nathan.murrell@nzta.govt.nz) / [www.nzta.govt.nz](http://www.nzta.govt.nz)  
Chews Lane Office / 50 Victoria Street  
Private Bag 6995, Wellington 6141, New Zealand

cid:image001.png@01D4BC73.BC0BD520



Released under the Official Information Act 1982

**From:** [Nathan Murrell](#)  
**To:** [Ben Gamboni](#); [Neil McAlpine](#); [Lynn Williams](#); [Robert Montgomery](#)  
**Subject:** PHL - new s198 draft  
**Date:** Monday, 27 May 2019 1:44:00 PM  
**Attachments:** [DRAFT 50108 Pacific Haulage Limited s198 Request 20190527.docx](#)  
[image001.png](#)  
[image002.jpg](#)  
[image003.jpg](#)  
[image004.jpg](#)  
[image005.jpg](#)

---

Hi everyone,

I have just completed a draft s198 request for PHL and would be very grateful for your input. The points all address the areas that they have either partially or fully failed to comply with for the previous request.

Some of the wording may need to be changed to get the right message across.

Ben – I will also draft a letter up along the lines of the email that we sent to s9(2)(b)(ii)

Regards,  
Nathan

**Nathan Murrell / Commercial Transport Officer**  
Road Compliance, Lower North Island  
DDI s9(2)(a) / M s9(2)(a)  
E [nathan.murrell@nzta.govt.nz](mailto:nathan.murrell@nzta.govt.nz) / w [nzta.govt.nz](http://nzta.govt.nz)  
Chews Lane Office / 50 Victoria Street  
Private Bag 6995, Wellington 6141, New Zealand

cid:image001.png@01D4BC73.BC0BD520

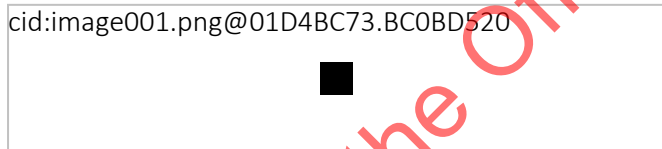

Released under the Official Information Act 1982

**From:** [Nathan Murrell](#)  
**To:** [Ben Gamboni](#)  
**Subject:** PHL Meeting Thursday 25.07.19  
**Date:** Tuesday, 16 July 2019 2:20:00 PM  
**Attachments:** [image001.jpg](#)  
[image002.png](#)  
[image003.jpg](#)  
[image004.jpg](#)  
[image005.jpg](#)  
[image006.jpg](#)

---

Hi Ben,

Just FYI that s9(2)(a) k has agreed to meeting at 9.00am next Thursday.  
Looks like Wendy and I will be meeting with the local management team initially which I think will be very beneficial, then following up with s9(2)(a) when he arrives later in the day.

Regards,  
Nathan

---

**From:** s9(2)(a)  
**Sent:** Tuesday, 16 July 2019 2:12 PM  
**To:** Nathan Murrell <[Nathan.Murrell@nzta.govt.nz](mailto:Nathan.Murrell@nzta.govt.nz)>  
**Cc:** s9(2)(a)  
**Subject:** RE: Further s198 request

Hi Nathan,

9am on the 25<sup>th</sup> will be fine.

s9(2)(a) and the management team will work through our systems with you, as I won't be in Gisborne until later in the day.

s9(2)(a) and has all the information you will need to see.

I will see you for a debrief before you leave if that is ok.

Regards

s9(2)(a)

s9(2)(a)

s9(2)(a)

cid:image003.jpg@01CF58AA.D03061B0

s9(2)(a)

s9(2)(a)

s9(2)(a)

s9(2)(a)

---

**From:** Nathan Murrell <[Nathan.Murrell@nzta.govt.nz](mailto:Nathan.Murrell@nzta.govt.nz)>  
**Sent:** Tuesday, 16 July 2019 11:20 AM  
**To:** s9(2)(a)  
**Subject:** RE: Further s198 request

Good morning [redacted]

Apologies for the late reply to this email, as you would have seen I was on leave last week.

I do agree that it would be beneficial for all of us to sit down and go through some of the systems and processes with you and the team in person.

It's important that we all see this as a collaborative approach, with the end goal being safer roads and a safer working environment for all involved.

I will be in Gisborne next Thursday 25<sup>th</sup> July and would like to schedule a meeting for around 9.00am?

I have ensured that I have no other commitments for the day until I fly out mid-afternoon, so we should have plenty of time.

If you could please let me know if this is suitable?

If so I look forward to seeing you there.

Regards,

Nathan

**Nathan Murrell / Commercial Transport Officer**

Road Compliance, Lower North Island

DDI [redacted] / M [redacted]

E [nathan.murrell@nzta.govt.nz](mailto:nathan.murrell@nzta.govt.nz) / W [nzta.govt.nz](http://nzta.govt.nz)

Chews Lane Office / 50 Victoria Street

Private Bag 6995, Wellington 6141, New Zealand

cid:image001.png@01D4BC73.BC0BD520

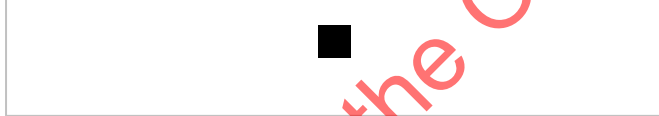

---

**From:** [redacted]

**Sent:** Monday, 8 July 2019 5:33 PM

**To:** Nathan Murrell <[Nathan.Murrell@nzta.govt.nz](mailto:Nathan.Murrell@nzta.govt.nz)>

**Subject:** RE: Further s198 request

Hi Nathan,

I agree with the focus on drug impaired drivers and wish it was part of roadside enforcement. This is the first such request that I have heard of and with respect, I would like to take some advice.

As I said in my letter, we test at pre-employment, probable cause and random, but also our customers test randomly.

Some of our managers are qualified to undertake testing, but we would see no need to record a

Released under the Official Information Act 1982

non-negative at pre-employment as we would not proceed.

I negative test would be retained so that our customer could then check the EWC records to make sure the person was not on the register.

s9(2)(a) so see the stats every month, often around 300 tests per month across all parts of the Forest Industry. We have a very low fail rate as a result.

If my advice comes back and it concurs with yours, I will provide the information.

In the interim, I would be happy to show you if you were able to visit again. You would benefit from taking to my management team and understand the process.

I think it would be beneficial with regard to our maintenance procedures also.

The record that I sent would be easier to be explained by my service manager, who could take you through the process that we run now.

You could then suggest any improvements, but with the changes we have made I think you will be happy.

Please give that some thought.

Regards

s9(2)(a)

s9(2)(a)

---

**From:** Nathan Murrell <[Nathan.Murrell@nzta.govt.nz](mailto:Nathan.Murrell@nzta.govt.nz)>

**Sent:** Friday, 5 July 2019 9:29 AM

**To:** s9(2)(a)

**Subject:** RE: Further s198 request

Good morning s9(2)(a)

I have recently received a response from the NZTA legal team in regards to our request for drug testing results.

NZTA take road safety very seriously, with drink and drug affected drivers being one of the high priority areas of focus.

In the interests of road safety and as part of the regular audit procedures you were asked to provide these records.

This is to ensure that you are taking all practical steps to ensure that Pacific Haulage Limited are operating safely in the interests of public safety.

The request under s198 Land Transport Act 1998 allows inspections and audits that the Agency reasonably considers necessary in the interests of land transport safety.

We see the trucking industry and logging industry personnel as being at high risk of the use and exposure to illicit drugs, and the risk is accentuated by the operation of heavy vehicles. To ensure road safety we do consider it be reasonable and necessary to request these records.

In regards to the privacy issue that you have cited, the Privacy Act can be overridden by other legislation such as the Land Transport Act. Therefore in providing this information as requested under s198, you would not be in breach of the Privacy Act.

I look forward to your response.

Nathan

**Nathan Murrell / Commercial Transport Officer**  
Road Compliance, Lower North Island  
DDI [redacted] / M [redacted]  
E [nathan.murrell@nzta.govt.nz](mailto:nathan.murrell@nzta.govt.nz) / w [nzta.govt.nz](http://nzta.govt.nz)  
Chews Lane Office / 50 Victoria Street  
Private Bag 6995, Wellington 6141, New Zealand



---

**From:** [redacted]  
**Sent:** Monday, 24 June 2019 5:19 PM  
**To:** Nathan Murrell <[Nathan.Murrell@nzta.govt.nz](mailto:Nathan.Murrell@nzta.govt.nz)>  
**Subject:** RE: Further s198 request

Hi Nathan,  
Attached is a letter and the information that you have requested. It may be in 2 emails. I am at a loss to understand the relevance of drug testing in a Compliance audit and have followed this up through the Road Transport Forum. The other issue that has been identified through a search of legislation, is the lack of definition of a Maintenance system and therefore I suspect that we may not agree on what is right or wrong. Much of risk management is covered under H&S legislation and Pacific Haulage has been audited many times with high scores. We have not had NZTA look at our business previously, assuming there has been no need to. Please advise if there are areas for improvement

Regards  
[redacted]

[redacted]

Released under the Official Information Act 1982

cid:image003.jpg@01CF58AA.D03061B0



s9(2)(a)

---

**From:** Nathan Murrell [<mailto:Nathan.Murrell@nzta.govt.nz>]  
**Sent:** Friday, 7 June 2019 4:34 p.m.  
**To:** s9(2)(a)  
**Subject:** Further s198 request

Good afternoon s9(2)(a)

Please find attached a new s198 request for information.

- Section 1 specifically requests employment agreements for the 6 listed drivers only.
- Section 2-4 requests overspeed reports and documentation around the management of speed related offending, to ensure operators are addressing high risk behaviours.
- This is currently a focus of the agency around managing high risk driving behaviours and is a part of all audits.  
The report under Section 2 is a simple overview and should be no more than 1-2 pages.
- Section 5 again seeks evidence to ensure that where drivers are committing offences on the road, that PHL are addressing those issues to manage risk.  
No information was provided on the previous request. Where this is not performed, I would be grateful for written confirmation.
- Section 6 requests evidence of drug testing documentation. Despite your assurances, there was no documentation previously submitted, including Shaun Smiths reported incident.
- Section 7 gives PHL another opportunity to provide evidence of driver daily vehicle inspections by way of physical daily checks sheets. Where this is not performed, I would be grateful for written confirmation.
- Section 8 seeks evidence that there is a clearly defined maintenance system in place, and that all maintenance is recorded. The previously supplied invoices from TPW are NOT evidence of a maintenance system.

I look forward to receiving your submissions.

Regards,

Released under the Official Information Act 1982

Nathan

Nathan Murrell / Commercial Transport Officer  
Road Compliance, Lower North Island

DDI s9(2)(a) [redacted] / M s9(2)(a) [redacted]  
E [nathan.murrell@nzta.govt.nz](mailto:nathan.murrell@nzta.govt.nz) / w [nzta.govt.nz](http://nzta.govt.nz)  
Chews Lane Office / 50 Victoria Street  
Private Bag 6995, Wellington 6141, New Zealand



Find the latest transport news, information, and advice on our website:  
[www.nzta.govt.nz](http://www.nzta.govt.nz)

---

This email is only intended to be read by the named recipient. It may contain information which is confidential, proprietary or the subject of legal privilege. If you are not the intended recipient you must delete this email and may not use any information contained in it. Legal privilege is not waived because you have read this email.

---

Find the latest transport news, information, and advice on our website:  
[www.nzta.govt.nz](http://www.nzta.govt.nz)

---

This email is only intended to be read by the named recipient. It may contain information which is confidential, proprietary or the subject of legal privilege. If you are not the intended recipient you must delete this email and may not use any information contained in it. Legal privilege is not waived because you have read this email.

---

Find the latest transport news, information, and advice on our website:  
[www.nzta.govt.nz](http://www.nzta.govt.nz)

---

This email is only intended to be read by the named recipient. It may contain information which is confidential, proprietary or the subject of legal privilege. If you are not the intended recipient you must delete this email and may not use any information contained in it. Legal privilege is not waived because you have read this email.

---

Released Under the Official Information Act 1982



**From:** [Nathan Murrell](#)  
**To:** [Lynn Williams](#)  
**Subject:** PHL  
**Date:** Friday, 7 June 2019 12:06:00 PM  
**Attachments:** [DRAFT 50108 Pacific Haulage Limited s198 Request 20190527.docx](#)  
[image001.png](#)  
[image002.jpg](#)  
[image003.jpg](#)  
[image004.jpg](#)  
[image005.jpg](#)

---

Hi Lynn,

Here is the copy of the new s198 that I have drafted.

I sent it to Ben earlier in the week but haven't had feedback from him yet, and really need to get it off to s9(2)(a) today.

Could you please let me know what you think (if you are working and available). I'm here until around 5pm having started later than normal today.

Cheers

Nathan

**Nathan Murrell / Commercial Transport Officer**

Road Compliance, Lower North Island

DDI s9(2)(a) / M s9(2)(a)

E [nathan.murrell@nzta.govt.nz](mailto:nathan.murrell@nzta.govt.nz) / w [nzta.govt.nz](http://nzta.govt.nz)

Chews Lane Office / 50 Victoria Street

Private Bag 6995, Wellington 6141, New Zealand

cid:image001.png@01D4BC73.BC0BD520

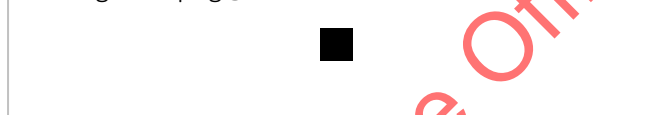

Released under the Official Information Act 1982

**From:** [Robert Montgomery](#)  
**To:** [Nathan Murrell](#)  
**Cc:** [Ben Gamboni](#)  
**Subject:** RE: CVST - Notes fields on electronic CVIRs  
**Date:** Friday, 19 July 2019 8:53:51 AM  
**Attachments:** [image001.png](#)  
[image002.jpg](#)  
[image003.jpg](#)  
[image004.jpg](#)  
[image005.jpg](#)

---

Hi Nathan

A very good point.

I will keep this and bring it up at our next meeting with CVST (s9(2)(a)). I think that we will get a better result by bringing it up at a face to face meeting rather than via email to him. Our next meeting is a few weeks away and I will ensure the matter is discussed.

I will also ask (s9(2)(a)) if he is able to raise this at a national level with CVST as I imagine the issue is not isolated to our region

Cheers

Rob

Rob Montgomery / Commercial Transport Advisor  
Lower North Island  
Regulatory Group  
DDI (s9(2)(a)) / M (s9(2)(a))  
E [robert.montgomery@nzta.govt.nz](mailto:robert.montgomery@nzta.govt.nz) / W [nzta.govt.nz](http://nzta.govt.nz)  
Palmerston North Office / Level 3, 43 Ashley Street,  
Private Bag 11777, Palmerston North 4440, New Zealand

---

**From:** Nathan Murrell  
**Sent:** Thursday, 18 July 2019 3:24 PM  
**To:** Robert Montgomery <[Robert.Montgomery@nzta.govt.nz](mailto:Robert.Montgomery@nzta.govt.nz)>  
**Cc:** Ben Gamboni <[Ben.Gamboni@nzta.govt.nz](mailto:Ben.Gamboni@nzta.govt.nz)>  
**Subject:** FW: CVST - Notes fields on electronic CVIRs

Whoops....helps if you attach the documents!

---

**From:** Nathan Murrell  
**Sent:** Thursday, 18 July 2019 3:19 PM  
**To:** Robert Montgomery <[Robert.Montgomery@nzta.govt.nz](mailto:Robert.Montgomery@nzta.govt.nz)>  
**Cc:** Ben Gamboni <[Ben.Gamboni@nzta.govt.nz](mailto:Ben.Gamboni@nzta.govt.nz)>  
**Subject:** CVST - Notes fields on electronic CVIRs

Hi Rob,

I was wondering if it's possible for a discussion to be had with CVST around data entry on CVIR's?

Included on the CVIR is a "Driver Notes" field that more often than not is left blank with no information.

I find this to be a hugely missed opportunity to include further information as to the interaction with the driver/vehicle/company etc, and relay vital information to the companies via CVIRs.

With doing a relatively detailed analysis for the Pacific Haulage Limited audit, I have been going through their offence history for the past two years.

This is in response to a comment that they "don't have a significant offence history".

I managed to run reports for both ION's issued directly to PHL, which are for offences such as "Not up to COF Standard" or overloading offences etc.

But I was also able to run offences by plate number i.e. PHL01, PHL02 etc and come up with a significant number of ION's issued personally to drivers for their own actions i.e. Seatbelt, speeding, logbook omissions.

What I have found is that the company does have an issue with offences, however unless the driver advises the company that they have incurred an offence, the company will likely never know about it and therefore not be able to act on it.

If we are to enable companies to manage their drivers in an appropriate manner, then it's imperative that they are fairly advised of offences that drivers are committing whilst in control of company vehicles.

By including comment to reflect the offence and issuing of any ION or warning in the "Driver Notes" field, then this will appear on the CVIR that is produced for the company.

I have included a copy of a couple of my CVIRs, as this was a common practice that <sup>s9(2)</sup> ~~(a)~~ and I both undertook with ours.

Also included is an example of two CVIRs for PHL vehicles (picked at random, no reflection on reporting officer) where the vehicles were stopped due to moving infringements, however no notes were included in the "Driver Notes" field.

As you can see, the speeding offence was pretty serious in nature with a 35km/h excess in a 50km/h zone.

The company should be fairly advised of this action as this is an employment matter that requires investigating and should result in a formal warning.

Having these fields filled where applicable also helps with our decisions making process for audit purposes where information is included as to the attitude of the driver, severity of the offence or defect etc.

Happy to discuss.

Regards,  
Nathan

**Nathan Murrell / Commercial Transport Officer**  
Road Compliance, Lower North Island

DDI <sup>s9(2)(a)</sup> ~~(a)~~ / M <sup>s9(2)(a)</sup> ~~(a)~~  
E [nathan.murrell@nzta.govt.nz](mailto:nathan.murrell@nzta.govt.nz) / w [nzta.govt.nz](http://nzta.govt.nz)  
Chews Lane Office / 50 Victoria Street

**From:** s9(2)(a)  
**To:** [Nathan Murrell](#)  
**Cc:** s9(2)(a)  
**Subject:** RE: Further s198 request  
**Date:** Tuesday, 16 July 2019 2:11:46 PM  
**Attachments:** [image001.jpg](#)  
[image002.png](#)  
[image003.jpg](#)  
[image004.jpg](#)  
[image005.jpg](#)  
[image006.jpg](#)

---

Hi Nathan,

9am on the 25<sup>th</sup> will be fine.

s9(2)(a) and the management team will work through our systems with you, as I won't be in Gisborne until later in the day.

s9(2)(a) and has all the information you will need to see.

I will see you for a debrief before you leave if that is ok.

Regards

s9(2)(a)

s9(2)(a)



---

**From:** Nathan Murrell <Nathan.Murrell@nzta.govt.nz>

**Sent:** Tuesday, 16 July 2019 11:20 AM

**To:** s9(2)(a)

**Subject:** RE: Further s198 request

Good morning s9(2)(a)

Apologies for the late reply to this email, as you would have seen I was on leave last week.

I do agree that it would be beneficial for all of us to sit down and go through some of the systems and processes with you and the team in person.

It's important that we all see this as a collaborative approach, with the end goal being safer roads and a safer working environment for all involved.

I will be in Gisborne next Thursday 25<sup>th</sup> July and would like to schedule a meeting for around 9.00am?

I have ensured that I have no other commitments for the day until I fly out mid-afternoon, so we should have plenty of time.

If you could please let me know if this is suitable?  
If so I look forward to seeing you there.

Regards,  
Nathan

Nathan Murrell / Commercial Transport Officer  
Road Compliance, Lower North Island  
DDI s9(2)(a) / M s9(2)(a)  
E [nathan.murrell@nzta.govt.nz](mailto:nathan.murrell@nzta.govt.nz) / w [nzta.govt.nz](http://nzta.govt.nz)  
Chews Lane Office / 50 Victoria Street  
Private Bag 6995, Wellington 6141, New Zealand

cid:image001.png@01D4BC73.BC0BD520

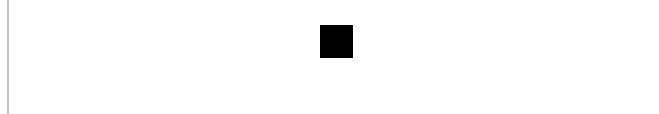

---

**From:** s9(2)(a)  
**Sent:** Monday, 8 July 2019 5:33 PM  
**To:** Nathan Murrell <[Nathan.Murrell@nzta.govt.nz](mailto:Nathan.Murrell@nzta.govt.nz)>  
**Subject:** RE: Further s198 request

Hi Nathan,

I agree with the focus on drug impaired drivers and wish it was part of roadside enforcement. This is the first such request that I have heard of and with respect, I would like to take some advice.

As I said in my letter, we test at pre-employment, probable cause and random, but also our customers test randomly.

Some of our managers are qualified to undertake testing, but we would see no need to record a non-negative at pre-employment as we would not proceed.

I negative test would be retained so that our customer could then check the EWC records to make sure the person was not on the register.

s9(2)(a), so see the stats every month, often around 300 tests per month across all parts of the Forest Industry. We have a very low fail rate as a result.

If my advice comes back and it concurs with yours, I will provide the information.

In the interim, I would be happy to show you if you were able to visit again. You would benefit from taking to my management team and understand the process.

I think it would be beneficial with regard to our maintenance procedures also.

The record that I sent would be easier to be explained by my service manager, who could take you through the process that we run now.

You could then suggest any improvements, but with the changes we have made I think you will be happy.

Please give that some thought.

Regards

Released under the Official Information Act 1982

s9(2)(a)

s9(2)(a)

---

**From:** Nathan Murrell <[Nathan.Murrell@nzta.govt.nz](mailto:Nathan.Murrell@nzta.govt.nz)>

**Sent:** Friday, 5 July 2019 9:29 AM

**To:** s9(2)(a)

**Subject:** RE: Further s198 request

Good morning s9(2)(a)

I have recently received a response from the NZTA legal team in regards to our request for drug testing results.

NZTA take road safety very seriously, with drink and drug affected drivers being one of the high priority areas of focus.

In the interests of road safety and as part of the regular audit procedures you were asked to provide these records.

This is to ensure that you are taking all practical steps to ensure that Pacific Haulage Limited are operating safely in the interests of public safety.

The request under s198 Land Transport Act 1998 allows inspections and audits that the Agency reasonably considers necessary in the interests of land transport safety.

We see the trucking industry and logging industry personnel as being at high risk of the use and exposure to illicit drugs, and the risk is accentuated by the operation of heavy vehicles.

To ensure road safety we do consider it be reasonable and necessary to request these records.

In regards to the privacy issue that you have cited, the Privacy Act can be overridden by other legislation such as the Land Transport Act.

Therefore in providing this information as requested under s198, you would not be in breach of the Privacy Act.

I look forward to your response.

Nathan

**Nathan Murrell / Commercial Transport Officer**  
Road Compliance, Lower North Island

DD s9(2)(a)

Released under the Official Information Act 1982

E [nathan.murrell@nzta.govt.nz](mailto:nathan.murrell@nzta.govt.nz) / w [nzta.govt.nz](http://nzta.govt.nz)  
Chews Lane Office / 50 Victoria Street  
Private Bag 6995, Wellington 6141, New Zealand

cid:image001.png@01D4BC73.BC0BD520



---

**From:** s9(2)(a)  
**Sent:** Monday, 24 June 2019 5:19 PM  
**To:** Nathan Murrell <[Nathan.Murrell@nzta.govt.nz](mailto:Nathan.Murrell@nzta.govt.nz)>  
**Subject:** RE: Further s198 request

Hi Nathan,

Attached is a letter and the information that you have requested. It may be in 2 emails.  
I am at a loss to understand the relevance of drug testing in a Compliance audit and have followed this up through the Road Transport Forum.

The other issue that has been identified through a search of legislation, is the lack of definition of a Maintenance system and therefore I suspect that we may not agree on what is right or wrong. Much of risk management is covered under H&S legislation and Pacific Haulage has been audited many times with high scores.

We have not had NZTA look at our business previously, assuming there has been no need to. Please advise if there are areas for improvement

Regards

s9(2)(a)



---

**From:** Nathan Murrell [<mailto:Nathan.Murrell@nzta.govt.nz>]  
**Sent:** Friday, 7 June 2019 4:34 p.m.  
**To:** s9(2)(a)  
**Subject:** Further s198 request

Good afternoon s9(2)(a)

Released under the Official Information Act 1982

Please find attached a new s198 request for information.

- Section 1 specifically requests employment agreements for the 6 listed drivers only.
- Section 2-4 requests overspeed reports and documentation around the management of speed related offending, to ensure operators are addressing high risk behaviours.
- This is currently a focus of the agency around managing high risk driving behaviours and is a part of all audits.

The report under Section 2 is a simple overview and should be no more than 1-2 pages.

- Section 5 again seeks evidence to ensure that where drivers are committing offences on the road, that PHL are addressing those issues to manage risk.

No information was provided on the previous request. Where this is not performed, I would be grateful for written confirmation.

- Section 6 requests evidence of drug testing documentation. Despite your assurances, there was no documentation previously submitted, including Shaun Smiths reported incident.
- Section 7 gives PHL another opportunity to provide evidence of driver daily vehicle inspections by way of physical daily checks sheets. Where this is not performed, I would be grateful for written confirmation.
- Section 8 seeks evidence that there is a clearly defined maintenance system in place, and that all maintenance is recorded. The previously supplied invoices from TPW are NOT evidence of a maintenance system.

I look forward to receiving your submissions.

Regards,

Nathan

Nathan Murrell / Commercial Transport Officer  
Road Compliance, Lower North Island

DDI [REDACTED] s9(2)(a)

E [nathan.murrell@nzta.govt.nz](mailto:nathan.murrell@nzta.govt.nz) / w [nzta.govt.nz](http://nzta.govt.nz)

Chews Lane Office / 50 Victoria Street  
Private Bag 6995, Wellington 6141, New Zealand

cid:image001.png@01D4BC73.BC0BD520





W [nzta.govt.nz](http://nzta.govt.nz)

Please consider the environment before printing this email

---

**From:** Nathan Murrell  
**Sent:** Thursday, 9 May 2019 1:16 PM  
**To:** Donna Sullivan <[Donna.Sullivan@nzta.govt.nz](mailto:Donna.Sullivan@nzta.govt.nz)>  
**Subject:** Re: Pacific Haulage Limited - -Accelerated driver licensing

I'm in a course all day, scheduled to have a break around 2.15-245pm.

I'll email as soon as we are out and you can call.

Cheers

Nathan Murrell  
Commercial Transport Officer  
New Zealand Transport Agency

T: s9(2)(a) [REDACTED]  
E: [nathan.murrell@nzta.govt.nz](mailto:nathan.murrell@nzta.govt.nz)

---

**From:** Donna Sullivan <[donna.sullivan@nzta.govt.nz](mailto:donna.sullivan@nzta.govt.nz)>  
**Sent:** Thursday, May 9, 2019 13:13  
**To:** Nathan Murrell  
**Subject:** RE: Pacific Haulage Limited - -Accelerated driver licensing

Hi Nathan

Can you let me know when your free so I can call you about this

Thanks  
Donna

Donna Sullivan / Lead Customer Assessments  
Licensing Assessments Team  
DDI 0800 822 422  
W [nzta.govt.nz](http://nzta.govt.nz)

Please consider the environment before printing this email

---

**From:** Nathan Murrell  
**Sent:** Thursday, 9 May 2019 12:46 PM  
**To:** Donna Sullivan <[Donna.Sullivan@nzta.govt.nz](mailto:Donna.Sullivan@nzta.govt.nz)>  
**Cc:** Lynn Williams <[Lynn.Williams@nzta.govt.nz](mailto:Lynn.Williams@nzta.govt.nz)>  
**Subject:** Pacific Haulage Limited - -Accelerated driver licensing

Hi Donna,

Could you please advise me if PHL have been given formal approval to operate under the accelerated driver licensing programme? If so could you please forward me the documentation around this?

We've been contacted by CVST who have recently pulled over drivers of PHL vehicles that are neither licensed nor under supervision, but showing a document as evidence of their exemption under the program.

It would be great to be able to clarify the conditions of their program so we can get back to CVST and make them aware of the conditions and how to deal with any breaches.

PHL are also currently under audit and we weren't too keen for the program to be implement at this stage, as it appears that there is work required in other areas of their operation to improve RID inspection pass rates.

Regards,  
Nathan

Nathan Murrell  
Commercial Transport Officer  
New Zealand Transport Agency

T: s9(2)(a)

E: [nathan.murrell@nzta.govt.nz](mailto:nathan.murrell@nzta.govt.nz)

Released under the Official Information Act 1982

**From:** [Nathan Murrell](#)  
**To:** [Ben Gamboni](#); [Anna Reed](#); [Robert Montgomery](#)  
**Subject:** RE: Pacific Haulage Limited - Crash 13.08.19  
**Date:** Wednesday, 14 August 2019 10:38:00 AM  
**Attachments:** [file1-1.jpeg](#)  
[file5-1.jpeg](#)  
[image001.png](#)  
[image002.jpg](#)  
[image003.jpg](#)  
[image004.jpg](#)  
[image005.jpg](#)

---

Whoops....photos attached FYI

---

**From:** Nathan Murrell  
**Sent:** Wednesday, 14 August 2019 10:38 AM  
**To:** Ben Gamboni <[Ben.Gamboni@nzta.govt.nz](mailto:Ben.Gamboni@nzta.govt.nz)>; Anna Reed <[Anna.Reed@nzta.govt.nz](mailto:Anna.Reed@nzta.govt.nz)>; Robert Montgomery <[Robert.Montgomery@nzta.govt.nz](mailto:Robert.Montgomery@nzta.govt.nz)>  
**Subject:** Pacific Haulage Limited - Crash 13.08.19

Hi everyone,

Following last week's decision with PHL, it's disappointing that I have received information this morning via Lynn that they rolled a unit yesterday near Gisborne.

I have spoken to both [s9\(2\)\(a\)](#) and [s9\(2\)\(a\)](#) this morning – the vehicle was travelling around a right hand bend with a 35km/h advisory, when it rolled to the left off the road. The driver admitted to driving between 40-50km/h. They were at PHL at the time that I spoke with them and were in the process of obtaining GPS records for the incident. I will keep in touch with them.

Unfortunately the driver just happens to be [s9\(2\)\(a\)](#)  
Ben signed off on a 5 year NOPR last week and I forwarded it to [s9\(2\)\(h\)](#) to arrange service.  
It's likely it has been served prior to the accident.

At least it confirms that the 2-5 revocations are targeting the right people.

Just thought it prudent to keep everyone informed.

Regards,  
Nathan

Nathan Murrell / Commercial Transport Officer  
Road Compliance, Lower North Island  
DDI [s9\(2\)\(a\)](#)  
E [nathan.murrell@nzta.govt.nz](mailto:nathan.murrell@nzta.govt.nz) / w [nzta.govt.nz](http://nzta.govt.nz)  
Chews Lane Office / 50 Victoria Street  
Private Bag 6995, Wellington 6141, New Zealand

cid:image001.png@01D4BC73.BC0BD520

■

**From:** [Nathan Murrell](#)  
**To:** [Ben Gamboni](#)  
**Subject:** RE: PHL - new s198 draft  
**Date:** Tuesday, 4 June 2019 1:37:00 PM  
**Attachments:** [image001.png](#)  
[image002.jpg](#)  
[image003.jpg](#)  
[image004.jpg](#)  
[image005.jpg](#)  
[DRAFT\\_50108\\_Pacific\\_Haulage\\_Limited\\_s198\\_Request\\_20190527.docx](#)

---

Hi Ben,

I've spoken to **s9(2)(a)** and advised that we have found information to be missing from the submissions made by PHL.

He was surprised, and genuinely believed that they had submitted everything. He did note that for privacy reasons that they admit excluding the driver address and phone numbers out. I didn't go into that part any further with him.

I've created a fairly paired down s198 request that just fills in the gaps. If you could take a look and let me know what you think.

The main issues are :

- vehicle maintenance i.e. all we got were invoices, nothing in the way of actual records.
- Drug testing – noted in the one crash report, but no drug records submitted. I've widened this to 12 months.
- No driver contracts supplied. Have requested 6 specified by name.
- Any records of daily vehicle checks.

I told him I would email it to him by the end of the week and happy to discuss it if he had any issues.

If there is anything you feel needs changing i.e. date ranges etc, please let me know.

Cheers  
Nathan

---

**From:** Ben Gamboni  
**Sent:** Wednesday, 29 May 2019 10:57 AM  
**To:** Nathan Murrell <[Nathan.Murrell@nzta.govt.nz](mailto:Nathan.Murrell@nzta.govt.nz)>; Lynn Williams <[Lynn.Williams@nzta.govt.nz](mailto:Lynn.Williams@nzta.govt.nz)>; Neil McAlpine <[Neil.McAlpine@nzta.govt.nz](mailto:Neil.McAlpine@nzta.govt.nz)>; Robert Montgomery <[Robert.Montgomery@nzta.govt.nz](mailto:Robert.Montgomery@nzta.govt.nz)>  
**Subject:** RE: PHL - new s198 draft

Hi,

A couple of questions/comments from me:

- Why do we need drivers' home addresses and contact telephone numbers?
- Ask for a minimum of 6x employment contracts rather than all of them. We don't need to check every single one and that makes the process a bit easier for us and

them.

- It may be worthwhile removing the requirement for the crash/incident reports in order to make this 198 request more focused. We've seen a copy of how they investigate and report on these incidents. Perhaps we could go down this path further down the line but at the moment let's focus on fatigue and speed/driving behaviour primarily. If there was a piece of info that was missing from the report that has been sent then ask for that specifically.
- Can we remove the requests for info that has already been supplied? (Not sure if it has but I don't want to go out and ask for everything again when they've already supplied some of it).

This request needs a phone call first as a courtesy to s9(2)(a) to explain in really simple terms what we've found so far in general terms i.e. we have some concerns around fatigue and vehicle maintenance as a result of our initial analysis but we aren't able to finalise our findings until we look at the information that wasn't supplied e.g. speed data etc. Let him know that we'll send that request out asking for the stuff they missed out last time

Nathan, once you've had that conversation with s9(2)(a) can you let me know how it went.

Thanks,  
Ben

---

**From:** Nathan Murrell  
**Sent:** Monday, 27 May 2019 1:59 PM  
**To:** Lynn Williams <[Lynn.Williams@nzta.govt.nz](mailto:Lynn.Williams@nzta.govt.nz)>; Ben Gamboni <[Ben.Gamboni@nzta.govt.nz](mailto:Ben.Gamboni@nzta.govt.nz)>; Neil McAlpine <[Neil.McAlpine@nzta.govt.nz](mailto:Neil.McAlpine@nzta.govt.nz)>; Robert Montgomery <[Robert.Montgomery@nzta.govt.nz](mailto:Robert.Montgomery@nzta.govt.nz)>  
**Subject:** RE: PHL - new s198 draft

The drug testing is included in 2), but perhaps I should have it as a separate point?  
Employment contracts are covered in 3), which I have amended slightly to say "all currently employed by PHL"

---

**From:** Lynn Williams  
**Sent:** Monday, 27 May 2019 1:51 PM  
**To:** Nathan Murrell <[Nathan.Murrell@nzta.govt.nz](mailto:Nathan.Murrell@nzta.govt.nz)>; Ben Gamboni <[Ben.Gamboni@nzta.govt.nz](mailto:Ben.Gamboni@nzta.govt.nz)>; Neil McAlpine <[Neil.McAlpine@nzta.govt.nz](mailto:Neil.McAlpine@nzta.govt.nz)>; Robert Montgomery <[Robert.Montgomery@nzta.govt.nz](mailto:Robert.Montgomery@nzta.govt.nz)>  
**Subject:** RE: PHL - new s198 draft

Hi Nathan

I've had a quick look and think that you should also include at least 6 x employment contracts (you name the drivers you want or let them send random ones) as well as all drug testing that has been completed on individual drivers during the month of ???

Regards

Lynn

---

**From:** Nathan Murrell  
**Sent:** Monday, 27 May 2019 1:44 PM  
**To:** Ben Gamboni <[Ben.Gamboni@nzta.govt.nz](mailto:Ben.Gamboni@nzta.govt.nz)>; Neil McAlpine <[Neil.McAlpine@nzta.govt.nz](mailto:Neil.McAlpine@nzta.govt.nz)>; Lynn Williams <[Lynn.Williams@nzta.govt.nz](mailto:Lynn.Williams@nzta.govt.nz)>; Robert Montgomery <[Robert.Montgomery@nzta.govt.nz](mailto:Robert.Montgomery@nzta.govt.nz)>  
**Subject:** PHL - new s198 draft

Hi everyone,

I have just completed a draft s198 request for PHL and would be very grateful for your input. The points all address the areas that they have either partially or fully failed to comply with for the previous request. Some of the wording may need to be changed to get the right message across.

Ben – I will also draft a letter up along the lines of the email that we sent to s9(2)(b)(i).

Regards,  
Nathan

Nathan Murrell / Commercial Transport Officer  
Road Compliance, Lower North Island  
DDI +s9(2)(a)  
E [nathan.murrell@nzta.govt.nz](mailto:nathan.murrell@nzta.govt.nz) / w [nzta.govt.nz](http://nzta.govt.nz)  
Chews Lane Office / 50 Victoria Street  
Private Bag 6995, Wellington 6141, New Zealand



Released under the Official Information Act 1982

**From:** [Ben Gamboni](#)  
**To:** [Robert Montgomery](#); [Nathan Murrell](#); [Lynn Williams](#)  
**Subject:** RE: Query in regards to "Breach of Privacy" vs s198 Land Transport Act 1998 Requests for Records  
**Date:** Friday, 5 July 2019 8:41:47 AM  
**Attachments:** [image001.png](#)  
[image002.jpg](#)  
[image003.jpg](#)  
[image004.jpg](#)  
[image005.jpg](#)

---

H Rob,

I agree. A conversation sounds like the best approach to me.

Cheers,  
Ben

---

**From:** Robert Montgomery  
**Sent:** Friday, 5 July 2019 8:28 AM  
**To:** Nathan Murrell <[Nathan.Murrell@nzta.govt.nz](mailto:Nathan.Murrell@nzta.govt.nz)>; Lynn Williams <[Lynn.Williams@nzta.govt.nz](mailto:Lynn.Williams@nzta.govt.nz)>; Ben Gamboni <[Ben.Gamboni@nzta.govt.nz](mailto:Ben.Gamboni@nzta.govt.nz)>  
**Subject:** RE: Query in regards to "Breach of Privacy" vs s198 Land Transport Act 1998 Requests for Records

Hi all.

s9(2)(h)



My opinion is that we should issue a new 198 demand requesting only the drug test results and driver details (and anything else that was missing from the first request). The demand could be 'beefed up' a little to clarify some of the advice that Andrew gives below. If the operator then again fails to provide the information requested then we could follow up with a prosecution for failing to facilitate an audit. That may then play out in court at a defended hearing which will provide us with a judicial result one way or the other.

However, that does not help us any in obtaining the records that we are seeking.

The alternative is to speak with [s9\(2\)\(a\)](#) and explain our legal advice and our options etc and see where it goes from there.

Regards

Rob

**Rob Montgomery**/Commercial Transport Advisor  
Lower North Island  
Regulatory Group

DDI [s9\(2\)\(a\)](#)

E [robert.montgomery@nzta.govt.nz](mailto:robert.montgomery@nzta.govt.nz) / W [nzta.govt.nz](http://nzta.govt.nz)

Palmerston North Office / Level 3, 43 Ashley Street,  
Private Bag 11777, Palmerston North 4440, New Zealand

---

**From:** Nathan Murrell

**Sent:** Thursday, 4 July 2019 1:39 PM

**To:** Lynn Williams <[Lynn.Williams@nzta.govt.nz](mailto:Lynn.Williams@nzta.govt.nz)>; Robert Montgomery <[Robert.Montgomery@nzta.govt.nz](mailto:Robert.Montgomery@nzta.govt.nz)>; Ben Gamboni <[Ben.Gamboni@nzta.govt.nz](mailto:Ben.Gamboni@nzta.govt.nz)>

**Subject:** FW: Query in regards to "Breach of Privacy" vs s198 Land Transport Act 1998 Requests for Records

Hi everyone,

s9(2)(h)

A large black rectangular redaction box covers the majority of the email body text.

I'd be interested in your thoughts and how we can move forward with PHL. Perhaps this could be a topic of conversation to cover with the whole team?

Regards,  
Nathan

---

**From:** Andrew Thompson

**Sent:** Thursday, 4 July 2019 12:31 PM

**To:** Nathan Murrell <[Nathan.Murrell@nzta.govt.nz](mailto:Nathan.Murrell@nzta.govt.nz)>

**Cc:** Lynn Williams <[Lynn.Williams@nzta.govt.nz](mailto:Lynn.Williams@nzta.govt.nz)>

**Subject:** RE: Query in regards to "Breach of Privacy" vs s198 Land Transport Act 1998 Requests for Records

Hi Nathan

Sorry for the delay and for the brevity of this reply.

s9(2)(h)

A large black rectangular redaction box covers the majority of the email body text.

Released under the Official Information Act 1982



s9(2)(h)

Cheers

Andrew Thompson BA LLB (Hons)  
Principal Counsel, Regulatory  
Legal Services Team / Corporate Services  
DDI s9(2)(a)  
E [andrew.thompson@nzta.govt.nz](mailto:andrew.thompson@nzta.govt.nz) / w [nzta.govt.nz](http://nzta.govt.nz)  
Dunedin Office Level 2, AA Centre, 450 Moray Place,  
PO Box 5245, Moray Place, Dunedin 9058, New Zealand

---

**From:** Nathan Murrell  
**Sent:** Tuesday, 25 June 2019 8:27 AM  
**To:** Andrew Thompson <[Andrew.Thompson@nzta.govt.nz](mailto:Andrew.Thompson@nzta.govt.nz)>  
**Cc:** Lynn Williams <[Lynn.Williams@nzta.govt.nz](mailto:Lynn.Williams@nzta.govt.nz)>  
**Subject:** Query in regards to "Breach of Privacy" vs s198 Land Transport Act 1998 Requests for Records

Good morning Andrew,

I have been speaking to Lynn Williams who has been mentoring me with an audit for a Gisborne based log haulage company, Pacific Haulage Limited.

We issued an initial s198 request for records in February, parts of which asked for a list of all current drivers along with their drivers licence number, address and contact phone number. Also requested was records for drug testing of drivers, either pre-employment, as a result of an incident, or random testing.

In the submissions that followed, the drivers list included drivers licence numbers, but no record of address or contact phone number.

No records for any drug testing were submitted.

When this was brought up with the company, director s9(2)(a) responded saying that providing the drivers contact details would be a breach of privacy, therefore they were not provided.

Although he was adamant that drug testing records were submitted, we assured him they were not.

A subsequent s 198 request was sent in early June with one of the points focusing on the submission of ALL drug testing records for a 12 month period.

We were presented with only one record relating to a traffic crash.

Correspondence again from s9(2)(a), stated that he was not of the belief that drug testing records should be requested as part of a compliance audit.

Although we have received the one record relating to the crash, he stated that "After taking advice, I am not able to provide the information requested, due to privacy issues."

What we would like assistance with is the issue of privacy vs our request for records.

Does the s198 request and in particular "s113A Power to Inspect Records" give us sufficient power to request in particular the drug testing records, but also the drivers contact details?

And does this override the companies want or need to protect privacy?

The drug testing is an employment record, and the Agency assess the companies risk management practices as important to road safety.

We would be grateful if someone in the team would be able to provide an opinion, so that we can go back to the company with a response.

I have included excerpts from the relevant sections below.

Regards,

Nathan

Nathan Murrell / Commercial Transport Officer

Road Compliance, Lower North Island

DDI s9(2)(a)

E [nathan.murrell@nzta.govt.nz](mailto:nathan.murrell@nzta.govt.nz) / w [nzta.govt.nz](http://nzta.govt.nz)

Chews Lane Office / 50 Victoria Street

Private Bag 6995, Wellington 6141, New Zealand

cid:image001.png@01D4BC73.BC0BD520

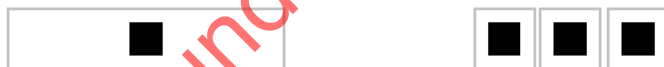

#### **198 Inspections and audits**

- (1) The Agency may in writing require any person who holds a land transport document that authorises the provision of a service in the land transport system to undergo such inspections and audits as the Agency reasonably considers necessary in the interests of land transport safety (including inspections and audits of vehicles operated by such persons).
- (2) The Agency may carry out such inspections and audits as the Agency reasonably considers necessary in the interests of land transport safety.
- (3) For the purposes of any inspection or audit carried out in respect of any person under this section, the Agency may in writing require that person to provide such information as the Agency reasonably considers relevant to the inspection or audit.
- (4) A person to whom a requirement is made under this section must comply with that requirement.

#### **113A Power to inspect records**

- (1) For the purpose of ascertaining whether this Act has been or is being complied with by any person to whom this Act applies, any enforcement officer in uniform or in possession of a warrant or other evidence of his or her authority as an enforcement

officer may require that person to produce without delay for inspection all relevant books or records in that person's possession or over which that person has control, including (but not limited to) records kept under section 65 of the Road User Charges Act 2012, logbooks, records associated with logbooks, financial records relating to expenditure on fuel, invoices, vehicle maintenance records, depreciation records for vehicles, time and wage records, and waybills.

- (2) The enforcement officer may take extracts from or make copies of any books or records so produced.

Released under the Official Information Act 1982